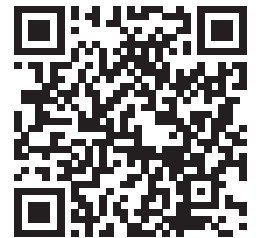


Operating Instructions and Parts Reference

# 2660/2665<sup>TM</sup> BALEBUSTER

2660 - Serial Number 2615000160 & Up

2665 - Serial Number 2615000165 & Up

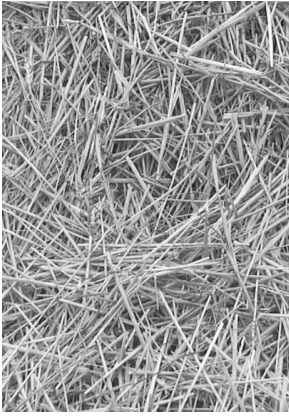


PRODUCT INFORMATION

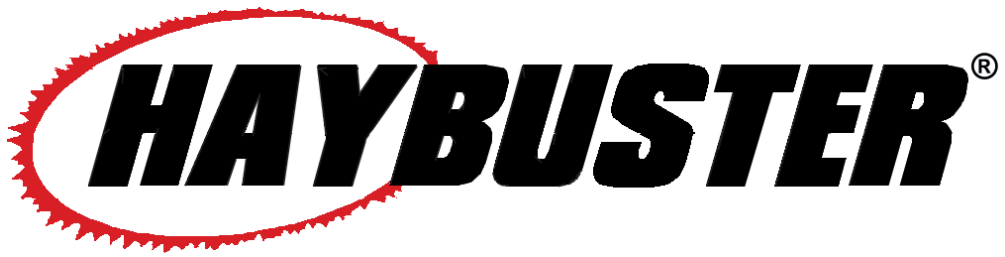
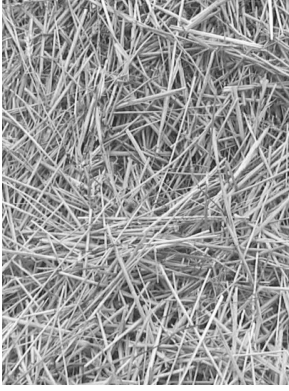


0500147 • JANUARY 2019

DURATECH INDUSTRIES INTERNATIONAL INC.  
PO BOX 1940, JAMESTOWN, ND 58402-1940  
TEL: (701) 252-4601 • FAX: (701) 252-0502  
WWW.DURATECHINDUSTRIES.NET • WWW.HAYBUSTER.COM



**HAYBUSTER<sup>®</sup>**  
*A Tradition of Innovation Since 1966*



**2660<sup>TM</sup> / 2665<sup>TM</sup>**

**BALEBUSTER**



**2660 - Serial Number 2615000160 & Up**

**2665 - Serial Number 2615000165 & Up**

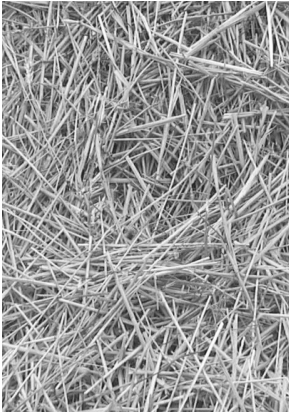
## **Operating Instructions and Parts Reference**

DuraTech Industries International Inc. (DuraTech Industries) has made every effort to assure that this manual completely and accurately describes the operation and maintenance of the 2660 and 2665 BALEBUSTERS<sup>TM</sup> as of the date of publication. DuraTech Industries reserves the right to make updates to the machine from time to time. Even in the event of such updates, you should still find this manual to be appropriate for the safe operation and maintenance of your unit.

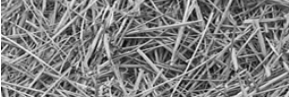
This manual, as well as materials provided by component suppliers to DuraTech Industries are all considered to be part of the information package. Every operator is required to read and understand these manuals, and they should be located within easy access for periodic review.

 **DURATECH**<sup>®</sup> &  **HAYBUSTER**<sup>®</sup> are registered trademarks of Duratech Industries International, Inc. 2660 BALEBUSTER and 2665 BALEBUSTER are trademarks of Duratech Industries International, Inc.

---



**HAYBUSTER**<sup>®</sup>  
*A Tradition of Innovation Since 1966*



## FOREWORD



## Foreword

All personnel must read and understand the following sections before operating the 2660/2665 *BALEBUSTER™*.

- Section 2, "Dealer Preparation," to verify that the machine has been prepared for use.
- Foreword and Section 1, important safety information.
- Section 3.1, "Pre-Operation Inspection".

### Appropriate use of unit

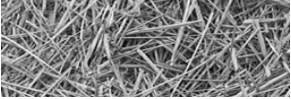
Your model 2660/2665 *BALEBUSTER* is designed to load and shred most types of baled livestock forage. It is designed for use on large round bales.



**To avoid possible damage to the machine and risk of injury to the operator, consult with a DuraTech Industries International, Inc. (DuraTech) representative before attempting to shred materials other than livestock forage.**

The 2660/2665 *BALEBUSTER* have multiple uses:

- Laying windrows in open fields.
- Filling feed bunks - fenceline, circular etc.
- Spreading forage for livestock bedding.
- Spreading forage over perennial plants, such as strawberries, mushrooms, etc.
- Spreading forage over reclaimed land areas.



## TABLE OF CONTENTS

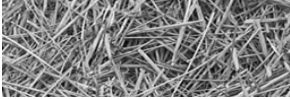
### Operator protection

As with all machinery, care needs to be taken in order to insure the safety of the operator and those in the surrounding area.



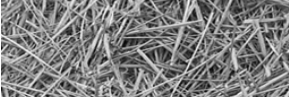
**WARNING:** The **OPERATOR IS RESPONSIBLE** for the safety of the operator and those in the surrounding area.

Operators of the 2660/2665 BALEBUSTER are **REQUIRED** to wear head, eye, and ear protection, no loose clothing is allowed.



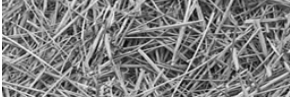
## TABLE OF CONTENTS

<b>Part I: Operating instructions .....</b>	<b>1</b>
<b>Introduction .....</b>	<b>2</b>
<b>Purpose .....</b>	<b>2</b>
<b>Section 1: Safety.....</b>	<b>4</b>
1.1 Safety-alert symbols .....	4
1.2 Operator - personal equipment .....	6
1.3 Machine safety labels .....	7
1.4 Shielding.....	9
1.5 Safety review Section .....	9
1.6 Towing/road transport .....	10
<b>Section 2: Dealer preparation .....</b>	<b>11</b>
2.1 Pre-delivery inspection.....	11
2.2 Shipping list and illustration for the 2660/2665 BALEBUSTER .....	12
2.3 Assembly required.....	14
<b>Section 3: Operation .....</b>	<b>16</b>
3.1 Pre-starting inspection instructions .....	16
3.2 Normal shutdown procedure .....	17
<b>3.3 Adjustments .....</b>	<b>17</b>
3.3.1 Hitch Adjustment .....	17
3.3.2 P.T.O. Shield .....	17
3.3.3 Conveyor Speed Control .....	18
3.3.5 Chain Case Adjustments.....	19
3.3.4 Conveyor Chain Adjustment .....	19
3.3.6 Slugbar Adjustment .....	20
3.3.7 Clean Out Door.....	20
3.3.8 Flails .....	21
3.3.9 Stripper Plate .....	21
3.3.10 Loader .....	22
3.3.13 Tires & Rims.....	24
3.3.11 Loader Transport Pin .....	24
3.3.12 Hydraulic Cylinder and Valve .....	24
3.3.14 Rack.....	25
3.3.15 Jack .....	25
3.3.16 Changing distribution pattern .....	26



## TABLE OF CONTENTS

3.4 Hitching the 2660/2665 BALEBUSTER .....	27
3.5 Unhitching the 2660/2665 BALEBUSTER .....	28
3.6 Starting the machine .....	28
3.7 Loading the bale .....	30
3.8 Shredding the bale .....	31
3.9 Twine Removal.....	32
3.10 Transporting the 2660/2665 BALEBUSTER .....	32
3.11 Storing the 2660/2665 BALEBUSTER .....	33
3.12 Removing the 2660/2665 BALEBUSTER from storage .....	33
<b>Section 4: Lubrication.....</b>	<b>34</b>
4.1 Lubrication .....	34
4.2 Grain Tank (Option) .....	39
4.3 General appearance .....	39
<b>Section 5: Troubleshooting.....</b>	<b>40</b>
<b>Section 6: 2660/2665 Balebuster Options.....</b>	<b>41</b>
6.1 Grain Tank Operation (Option) .....	41
6.2 Grain Tank (Option) Calibration Procedure .....	42
6.3 Hydraulic Deflector (Option) .....	44
6.4 Hydraulic Slug Bar (Option) .....	45
6.5 Containment Flap (Option) .....	46
6.6 Containment Extensions (Option) .....	46
<b>Section 7: Maintenance .....</b>	<b>47</b>
7.1 Welding Procedure .....	47
<b>Appendix A: WARRANTY.....</b>	<b>48</b>
<b>Appendix B: 2660/2665 Specifications.....</b>	<b>49</b>
<b>Appendix C: Grain tank (Option) Specifications .....</b>	<b>50</b>



**TABLE OF CONTENTS**

**Part II: Parts Reference.....51**

2660 SHREDDER ASSEMBLY - FRONT ..... 52

2660 SHREDDER ASSEMBLY - DOOR..... 54

2660 SHREDDER ASSEMBLY - SLUGBAR ..... 56

2660 SHREDDER ASSEMBLY - ROTOR (S.N. 0001 THRU 0005)..... 58

2660 SHREDDER ASSEMBLY - ROTOR (S.N. 0006 AND UP) ..... 60

2660 SHREDDER ASSEMBLY - FLOOR PAN ..... 62

2665 SHREDDER ASSEMBLY - FRONT ..... 64

2665 SHREDDER ASSEMBLY - DOOR..... 66

2665 SHREDDER ASSEMBLY - SLUGBAR ..... 68

2665 SHREDDER ASSEMBLY - ROTOR (S.N. 0001 THRU 0005)..... 70

2665 SHREDDER ASSEMBLY - ROTOR (S.N. 0006 AND UP) ..... 72

2665 SHREDDER ASSEMBLY - FLOOR PAN ..... 74

REAR SHIELD ..... 76

MANUAL CANISTER ASSEMBLY ..... 78

LOADER MOUNT AND TINES ASSEMBLY ..... 80

RACK AND DEFLECTOR ASSEMBLY ..... 82

2660 CONVEYOR ASSEMBLY (S.N. 0001 THRU 0005) &  
2665 CONVEYOR ASSEMBLY (S.N. 0001 THRU 0005)..... 84

2660 CONVEYOR ASSEMBLY (S.N. 0006 & UP) &  
2665 CONVEYOR ASSEMBLY (S.N. 0006 & UP) ..... 86

2660 DRIVE CHAIN ASSEMBLY (S.N. THRU 0005) &  
2665 DRIVE CHAIN ASSEMBLY (S.N. THRU 0005) ..... 88

2660 DRIVE CHAIN ASSEMBLY (S.N. 0006 AND UP) &  
2665 DRIVE CHAIN ASSEMBLY (S.N. 0006 AND UP) ..... 90

STANDARD DRIVE LINE ASSEMBLY..... 92

CONSTANT VELOCITY DRIVE LINE ASSEMBLY ..... 94

MAIN FRAME ASSEMBLY ..... 96

2660 WHEEL AND BEARING & 2665 WHEEL AND BEARING ..... 98

PTO ASSEMBLY #3600459 ..... 100

PTO ASSEMBLY #3600684 ..... 102

HYDRAULIC HOSES AND FITTINGS ..... 104

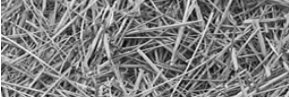
ORBIT MOTOR..... 106

FLOW CONTROL VALVE ..... 107

FLOW CONTROL VALVE 4000331 ..... 108

HYDRAULIC DEFLECTOR (OPTION) ..... 110

HYDRAULIC SLUGBAR (OPTION) ..... 112



**TABLE OF CONTENTS**

CONTAINMENT EXTENSIONS (OPTION) ..... 114

CONTAINMENT FLAP (OPTION) ..... 116

OPTIONAL WIDE DEFLECTOR BELT ..... 118

TAILLIGHT - STD. MOUNTING..... 120

OPTIONAL TAILLIGHT - FENDER MOUNTING  
(USE WITH HIGHWAY TIRES ONLY) ..... 122

5701079 SHREDDER TAIL LIGHT SCHEMATIC..... 124

OPTIONAL FENDER ..... 126

GRAIN TANK (OPTION) ASSEMBLY (O-RING) ..... 128

GRAIN TANK (OPTION) ASSEMBLY (O-RING) - DETAILS A&B ..... 129

GRAIN TANK (OPTION) ASSEMBLY (O-RING) - TANK DETAILS..... 130

GRAIN TANK (OPTION) ASSEMBLY (O-RING) - PARTS LIST ..... 131

GRAIN TANK (OPTION) HYDRAULICS DETAILS (O-RING) ..... 132

2660 STRIPPER BAR (OPTION) INSTALLATION &  
2665 STANDARD STRIPPER BAR INSTALLATION..... 134

WEIGH SCALE - LOAD CELL (OPTION) ..... 136

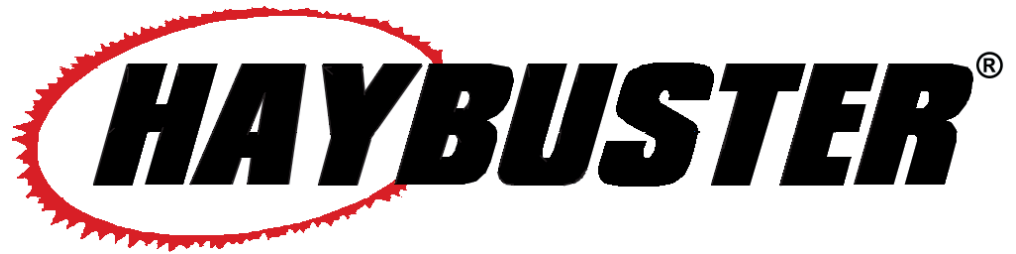
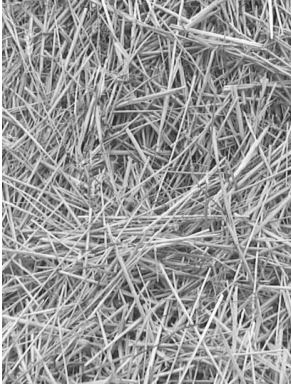
AXLE EXTENSIONS (OPTION) ..... 138

DECALS ..... 140

DECAL LOCATIONS ..... 142

**2660/2665 BALEBUSTER DOCUMENTATION COMMENT FORM .... 145**





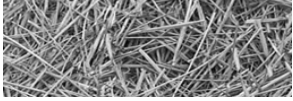
**2660<sup>TM</sup> / 2665<sup>TM</sup>**

**BALEBUSTER**

**2660 - Serial Number 2615000160 & Up**

**2665 - Serial Number 2615000165 & Up**

## **PART 1: Operating Instructions**



# Introduction

Your model 2660/2665 BALEBUSTER™ is designed to load and shred most types of livestock forage. It is designed specifically for use on 6 foot diameter round bales weighing up to 2,000 pounds and 6 feet in length.

To avoid possible damage to the machine and risk of injury to the operator, consult with a DuraTech Industries International, Inc. (DuraTech Industries) representative before attempting to shred materials other than livestock forage.

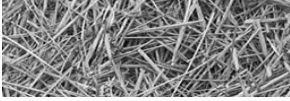
## Purpose

The purpose of this owner's manual is to explain maintenance requirements and routine adjustments for the most efficient operation of your 2660/2665 BALEBUSTER. There is also a trouble shooting section that may help in case of problems in the field. Any information not covered in this manual may be obtained from your dealer.



**Special Note:** When reference is made as to front, rear, right hand or left hand of this machine, the reference is always made from standing at the rear end of the machine and looking towards the hitch. Always use serial number and model number when referring to parts or problems. Please obtain your serial number and write it below for your future reference.

MODEL: 2660/2665 BALEBUSTER SERIAL NO \_\_\_\_\_



# How to use this manual

## Manual organization

This manual is organized into the following parts:

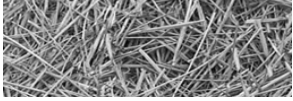
- **Part 1: Operating instructions** explain how to set up, use and maintain the 2660/2665 BALEBUSTER.
- **Part 2: Parts reference** contains diagrams of each assembly, with the part number of each part. A key on the facing page contains a description of the part and the quantity used.

## Dealer responsibilities

- Read Section 2, “Dealer Preparation,” and perform the tasks outlined. Also perform a pre-operation inspection as described in Section 3.2.1.
- Upon delivery of the unit to the customer, it is your responsibility to conduct a training session on the safe operation of the unit for the primary operator(s). You must also conduct a “walk-around” inspection of all safety instructional decals on the machine itself. Decals are illustrated in **Part 2: Parts Reference**.
- Complete and return the Warranty Registration Card. Receipt of this form is required to activate the warranty. **Appendix A** provides details of the warranty.

## Operator responsibilities

- Operator is responsible for his safety.
- Operator is also responsible for safety of others near the machine.
- Review Section 2, “Dealer Preparation,” to verify that the machine has been prepared for use.
- Thoroughly review sections 1 and 3, which explain normal operation of the machine, and section 4, which explain maintenance requirements.
- Note the important safety information in the Foreword and in Section 1, “Safety.”
- Keep copies of all manuals in a readily accessible location for future reference.



## Section 1: Safety

The safety of the operator is of great importance to DuraTech Industries. We have provided decals, shield and other safety features to aid you in using your machine safely. In addition, we ask you to be a careful operator who will properly use and service your Haybuster equipment.



**WARNING:** FAILURE TO COMPLY WITH SAFETY INSTRUCTIONS THAT FOLLOW WITHIN THIS MANUAL COULD RESULT IN SEVERE PERSONAL INJURY OR DEATH. BEFORE ATTEMPTING TO OPERATE THIS MACHINE, CAREFULLY READ ALL INSTRUCTIONS CONTAINED WITHIN THIS MANUAL. ALSO READ THE INSTRUCTION MANUAL PROVIDED WITH YOUR TRACTOR.

THIS MACHINE IS NOT TO BE USED FOR ANY PURPOSE OTHER THAN THOSE EXPLAINED IN THE OPERATOR'S MANUAL, ADVERTISING LITERATURE OR OTHER DURATECH INDUSTRIES WRITTEN MATERIAL PERTAINING TO THE 2660/2665 BALEBUSTER.

### 1.1 Safety-alert symbols

Decals are illustrated in **Part 2: Parts Reference**.

The safety decals located on your machine contain important and useful information that will help you operate your equipment safely.

To assure that all decals remain in place and in good condition, follow the instructions below:

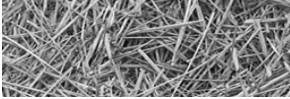
- Keep decals clean. Use soap and water - not mineral spirits, adhesive cleaners and other similar cleaners that will damage the decal.
- Replace all damaged or missing decals. When attaching decals, surface temperature of the machine must be at least 40° F (5° C). The surface must be also be clean and dry.
- When replacing a machine component to which a decal is attached, be sure to also replace the decal.

DuraTech Industries uses industry accepted **ASAE** standards in labeling its products for safety and operational characteristics.



### **Safety-Alert Symbol**

Read and recognize safety information. Be alert to the potential for personal injury when you see this safety-alert symbol.



**DANGER:** Indicates an imminently hazardous situation that, if not avoided, will result in death or serious injury. This signal word is to be limited to the most extreme situations, typically for machine components that, for functional purposes, cannot be guarded.

**WARNING:** Indicates a potentially hazardous situation that, if not avoided, could result in death or serious injury, and includes hazards that are exposed when guards are removed. It may also be used to alert against unsafe practices.

**CAUTION:** Indicates a potentially hazardous situation that, if not avoided, may result in minor or moderate injury. It may also be used to alert against unsafe practices.

This manual uses the symbols to the right to denote important safety instructions and information.

The **DANGER**, **WARNING** and **CAUTION** symbols are used to denote conditions as stated in the text above. Furthermore, the text dealing with these situations is surrounded by a box with a white background, will begin with **DANGER**, **WARNING**, or **CAUTION**.

The **INFORMATION** symbol is used to denote important information or notes in regards to maintenance and use of the machine. The text for this information is surrounded by a box with a light grey background, and will begin with either **Important** or **Note**.



**DANGER:**  
Signal word - White Lettering/Red Background  
Safety Alert Symbol - White Triangle/Red Exclamation Point



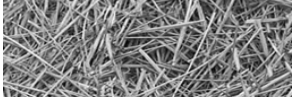
**WARNING:**  
Signal word - Black Lettering/Orange Background  
Safety Alert Symbol - Black Triangle/Orange Exclamation Point



**CAUTION:**  
Signal word - Black Lettering/Yellow Background  
Safety Alert Symbol - Black Triangle/Yellow Exclamation Point



	<p>1. Yellow warning triangle/black graphical symbol, indicates what the hazard is. Hazard Identification</p>
	<p>2. Red circle-with-slash/black graphical symbol indicates a prohibited action to avoid the hazard. Prohibited Action</p>
	<p>3. Blue mandatory action circles/white graphical symbol - indicates an action to take to avoid the hazard. Mandatory Action</p>



## 1.2 Operator - personal equipment

### THE OPERATOR

#### Physical Condition

You must be in good physical condition and mental health and not under the influence of any substance (drugs, alcohol) which might impair vision, dexterity or judgment.

Do not operate a **2660/2665 BALEBUSTER** when you are fatigued. Be alert - If you get tired while operating your **2660/2665 BALEBUSTER**, take a break. Fatigue may result in loss of control. Working with any farm equipment can be strenuous. If you have any condition that might be aggravated by strenuous work, check with your doctor before operating

#### Proper Clothing



Clothing must be sturdy and snug-fitting, but allow complete freedom of movement. Avoid loosefitting jackets, scarfs, neckties, jewelry, flared or cuffed pants, unconfined long hair or anything that could become entangled with the machine.



Protect your hands with gloves when handling flail and sections. Heavyduty, nonslip gloves improve your grip and protect your hands.



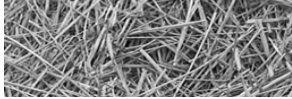
Good footing is most important. Wear sturdy boots with nonslip soles. Steel-toed safety boots are recommended.



To reduce the risk of injury to your eyes never operate a **2660/2665 BALEBUSTER** unless wearing goggles or properly fitted safety glasses with adequate top and side protection.




Tractor noise may damage your hearing. Always wear sound barriers (ear plugs or ear muffers) to protect your hearing. Continual and regular users should have their hearing checked regularly.



### 1.3 Machine safety labels


The safety decals located on your machine contain important information that will help you operate your equipment. Become familiar with the decals and their locations.

 **DANGER:** FLYING HAY, ROCKS, AND OTHER OBJECTS THROWN BY MACHINE.

STAY CLEAR OF DISCHARGE SIDE OF MACHINE UNLESS OPERATOR HAS STOPPED TRACTOR ENGINE AND MACHINE HAS STOPPED ROTATING. FAILURE TO FOLLOW THESE INSTRUCTIONS MAY RESULT IN SEVERE PERSONAL INJURY OR DEATH.

<p><b>⚠ DANGER</b></p> 	<p><b>FLYING HAY, ROCKS, AND OTHER OBJECTS THROWN BY MACHINE.</b></p> <p>STAY CLEAR OF DISCHARGE SIDE OF MACHINE UNLESS OPERATOR HAS STOPPED TRACTOR ENGINE AND MACHINE HAS STOPPED ROTATING.</p> <p>FAILURE TO FOLLOW THESE INSTRUCTIONS MAY RESULT IN SEVERE PERSONAL INJURY OR DEATH.</p>
<p><b>⚠ PELIGRO</b></p> 	<p><b>LA PAJA, LAS PEORAS Y OTRAS COSAS TIRADAS POR LA MAQUINA.</b></p> <p>NO SE PARE JUNTO AL LADO DE PARADOR DE LA MAQUINA SI EL MOTOR ESTA EN MARCHA Y LAS PALETAS ESTAN EN MOVIMIENTO.</p> <p>NO SIGUIR ESTAS INSTRUCCIONES PUEDE RESULTAR EN HERIDAS GRAVES E INCLUSO LA MUERTE.</p>


6500034

 **DANGER:** ROTATING FLAILS CAN KILL OR DISMEMBER

KEEP CLEAR OF MACHINE UNTIL POWER TAKE-OFF HAS BEEN DISENGAGED, TRACTOR ENGINE SHUT OFF AND FLAIL ROTATION STOPPED

<p><b>⚠ DANGER PELIGRO</b></p>	<p><b>ROTATING FLAILS CAN KILL OR DISMEMBER</b></p> <p>KEEP CLEAR OF MACHINE UNTIL POWER TAKE-OFF HAS BEEN DISENGAGED, TRACTOR ENGINE SHUT OFF AND FLAIL ROTATION STOPPED</p>	<p><b>LAS PALETAS EN MOVIMIENTO PUEDEN DESMEMBRAR E INCLUSO MATAR</b></p> <p>MANTENGA SU DISTANCIA HASTA QUE SE DESCONECTE LA TOMA DE FUERZA. EL MOTOR PARE Y LAS PALETAS DEJEN DE MOVERSE</p>
--------------------------------	---	--


6500035

 **DANGER:** ROTATING DRIVELINE, CONTACT CAN CAUSE DEATH, KEEP AWAY!


ENTANGLEMENT CAN CAUSE SERIOUS INJURY OR DEATH

DO NOT OPERATE WITHOUT

- ALL DRIVELINE GUARDS, TRACTOR AND EQUIPMENT SHIELDS IN PLACE
- DRIVELINES SECURELY ATTACHED AT BOTH ENDS
- DRIVELINE GUARDS THAT TURN FREELY ON DRIVELINE

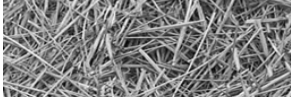
<p><b>⚠ DANGER</b></p>

<p><b>Rotating Driveline Keep Away!</b> Entanglement can cause serious injuries or death.</p> <p><b>Do Not Operate Without -</b></p> <ul style="list-style-type: none"> <li>• All driveline guards, tractor and equipment shields in place.</li> <li>• Drivelines securely attached at both ends.</li> </ul> <p>6500085</p>

6500085

 **WARNING:** FOR YOUR PROTECTION KEEP ALL SHIELDS IN PLACE AND SECURED WHILE MACHINE IS OPERATING MOVING PARTS WITHIN CAN CAUSE SEVERE PERSONAL INJURY.

<p><b>⚠ WARNING</b></p>	<p><b>⚠ ADVERTENCIA</b></p>
<p>FOR YOUR PROTECTION KEEP ALL SHIELDS IN PLACE AND SECURED WHILE MACHINE IS OPERATING. MOVING PARTS WITHIN CAN CAUSE SEVERE PERSONAL INJURY.</p>	<p>PARA ASEGURAR SU PROTECCION, MANTENGA TODOS LOS PROTECTORES EN SU LUGAR Y ASEGURADOS MIENTRAS LA MAQUINA ESTE OPERANDO. LAS PIEZAS MOVILES INTERNAS PUEDEN CAUSAR LESIONES PERSONALES GRAVES.</p>

6500040



**WARNING: FOR YOUR PROTECTION AND PROTECTION OF OTHERS, PRACTICE THE FOLLOWING SAFETY RULES.**

1. BEFORE OPERATING THIS MACHINE, READ THE OPERATOR'S MANUALS SUPPLIED WITH THIS MACHINE AND YOUR TRACTOR.
2. CHECK OPERATORS MANUALS TO BE SURE YOUR TRACTOR MEETS THE MINIMUM REQUIREMENTS FOR THIS MACHINE.
3. READ ALL DECALS PLACED ON THIS MACHINE FOR YOUR SAFETY AND CONVENIENCE.
4. NEVER ALLOW RIDERS ON THIS IMPLEMENT OR THE TRACTOR.
5. KEEP OTHERS AWAY FROM THIS MACHINE WHILE IN OPERATION.
6. KEEP ALL SHIELDS IN PLACE WHILE MACHINE IS OPERATING.
7. KEEP HANDS, FEET, LOOSE CLOTHING, ETC., AWAY FROM POWER DRIVEN PARTS.
8. ALWAYS SHUT OFF MACHINE AND ENGINE BEFORE SERVICING, UNCLOGGING, INSPECTING, OR WORKING NEAR THIS MACHINE FOR ANY REASON. ALWAYS PLACE TRANSMISSION IN PARK OR SET PARK BRAKE AND WAIT FOR ALL MOVEMENT TO STOP BEFORE APPROACHING THIS MACHINE.

**WARNING**

FOR YOUR PROTECTION AND PROTECTION OF OTHERS, PRACTICE THE FOLLOWING SAFETY RULES.

1. BEFORE OPERATING THIS MACHINE, READ THE OPERATOR'S MANUALS SUPPLIED WITH THIS MACHINE AND YOUR TRACTOR.
2. CHECK OPERATOR MANUALS TO BE SURE YOUR TRACTOR MEETS THE MINIMUM REQUIREMENTS FOR THIS MACHINE.
3. READ ALL DECALS PLACED ON THIS MACHINE FOR YOUR SAFETY AND CONVENIENCE.
4. NEVER ALLOW RIDERS ON THIS IMPLEMENT OR THE TRACTOR.
5. KEEP OTHERS AWAY FROM THIS MACHINE WHILE IN OPERATION.
6. KEEP ALL SHIELDS IN PLACE WHILE MACHINE IS OPERATING.
7. KEEP HANDS, FEET, LOOSE CLOTHING, ETC. AWAY FROM POWER DRIVEN PARTS.
8. ALWAYS SHUT OFF MACHINE AND ENGINE BEFORE SERVICING, UNCLOGGING, INSPECTING, OR WORKING NEAR THIS MACHINE FOR ANY REASON. ALWAYS PLACE TRANSMISSION IN PARK OR SET PARK BRAKE AND WAIT FOR ALL MOVEMENT TO STOP BEFORE APPROACHING THIS MACHINE.

**ADVERTENCIA**

SIGA LAS REGLAS SIGUIENTES DE SEGURIDAD PARA SU PROTECCION Y LA PROTECCION DE OTROS

1. LEA LOS MANUALES DEL OPERADOR INCLUIDOS CON ESTA MAQUINA Y SU TRACTOR ANTES DE OPERAR ESTA MAQUINA.
2. PARA ASEGURARSE QUE SU TRACTOR CUMPLE CON LOS REQUISITOS MÍNIMOS PARA ESTA MAQUINA, REVISÉ LOS MANUALES DEL OPERADOR.
3. PARA SU SEGURIDAD Y CONVENIENCIA, LEA TODAS LAS CALCOMANÍAS COLOCADAS EN LA MAQUINA.
4. NUNCA PERMITA PASAJEROS EN ESTA MAQUINA O EN EL TRACTOR.
5. MANTÉNGA ALEJADOS A LOS ESPECTADORES MIENTRAS ESTA MAQUINA ESTE OPERANDO.
6. MANTÉNGA TODOS LOS PROTECTORES EN SU LUGAR MIENTRAS LA MAQUINA ESTE OPERANDO.
7. MANTÉNGA LAS MANOS, PIES, ROPAS SUELTAS, ETC., ALEJADAS DE LAS PIEZAS PROPULSADAS.
8. DESPUESE APAGUE LA MAQUINA Y EL MOTOR ANTES DE PRESTAR SERVICIO, DESTABAR, INSPECCIONAR O TRABAJAR CERCA DE ESTA MAQUINA POR CUALQUIER MOTIVO. ANTES DE ACERCARSE A ESTA MAQUINA COLOQUE SIEMPRE LA TRANSMISION EN ESTACIONAMIENTO O ENGANCHE EL FRENO DE ESTACIONAMIENTO.

6500041

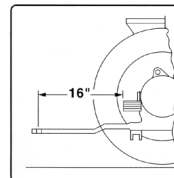


**WARNING: NO STEP DO NOT STEP, STAND, OR SIT ON THIS SURFACE. MAY CAUSE INJURY AND/OR EQUIPMENT DAMAGE.**

6500490



**CAUTION: ADJUST TRACTOR DRAWBAR SO THAT THE DISTANCE FROM THE END OF THE P.T.O. SHAFT ON THE TRACTOR TO THE CENTER OF THE DRAWBAR HITCH PIN IS 16".**



**CAUTION**

1. ADJUST TRACTOR DRAWBAR SO THAT THE DISTANCE FROM THE END OF THE PTO SHAFT ON THE TRACTOR TO THE CENTER OF THE DRAWBAR HITCH PIN IS 16".
2. ADJUST THE HITCH CLEVIS SO THE MACHINE IS PARALLEL WITH THE GROUND WHEN HITCHED TO TRACTOR.
3. HITCH MACHINE TO TRACTOR WITH A 1" HITCH PIN AND SECURE TO PREVENT LOSS.
4. ADJUST PTO BEARING BRACKET SO THE SHAFT ON THE MACHINE IS LEVEL WITH THE PTO SHAFT ON THE TRACTOR.

SEE OWNERS MANUAL FOR MORE INFORMATION

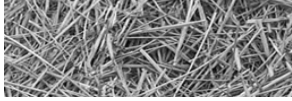
**PRECAUCIÓN**

1. AJUSTAR LA BARRA DE TIRO DEL TRACTOR DE MODO QUE LA DISTANCIA DEL EXTREMO DEL EJE DE LA TDP DEL TRACTOR AL CENTRO DEL PASADOR DEL ENGANCHE DE LA BARRA DE TIRO MIDA 16 pulgadas (406.4 mm).
2. AJUSTAR LA HORQUILLA DEL ENGANCHE DE MODO QUE LA MAQUINA QUEDA PARALELA CON EL SUELO CUANDO ESTA ENGANCHADA AL TRACTOR.
3. ENGANCHAR LA MAQUINA AL TRACTOR CON UN PASADOR DE ENGANCHE DE 1 pulg (25.4 mm) Y FIJARLO PARA EVITAR LA DESCONEXION.
4. AJUSTAR LA ESCUADRIA DEL COJINETE DE LA TDP DE MODO QUE EL EJE DE LA MAQUINA QUEDA AL MISMO NIVEL CON EL EJE DE LA TDP DEL TRACTOR.

VER EL MANUAL DEL OPERADOR PARA MAS INFORMACION.

6500322

- Replacement decals can be purchased from your Haybuster dealer.



## 1.4 Shielding

Shields are installed for your protection. Keep them in place, and replace damaged shields.

## 1.5 Safety review Section

### BEFORE OPERATING

- Read and follow all instructions contained in:
  - a. This 2660/2665 BALEBUSTER operator's manual
  - b. Tractor operator's manual
  - c. Decals placed on the 2660/2665 BALEBUSTER.

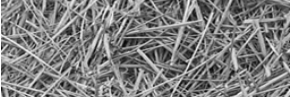


**NOTE:** Additional copies of the above mentioned materials can be obtained from your dealer.

- Allow only responsible, properly instructed individuals to operate your machine. Carefully supervise inexperienced operators.
- Use a tractor which meets the tractor requirement contained within this manual. Additional weights may be necessary.
- Make sure the machine is in good operating condition and that all protective shields are in place and in proper working order. Replace damaged shields before operating.
- Be sure all bystanders and other workers are clear before starting tractor and 2660/2665 BALEBUSTER.
- Make no modifications to the machine unless specifically recommended or requested by DuraTech Industries.
- Check periodically for breaks or unusual wear and make any necessary repairs.
- Be sure the unit is securely attached to a tractor of equal or greater weight than the 2660/2665 BALEBUSTER and bale.
- If required install P.T.O. safety chain, check local regulations regarding safety chain requirements.

### DURING OPERATION

- Enforce the following safety precautions and others contained in this manual to prevent serious personal injury or death due to accidental contact with rotating flails.
  - a. Everyone must be kept clear of work area except operator seated at tractor controls.
  - b. Disengage P.T.O. and make sure everyone is clear of machine before starting engine.
- Enforce the following safety precautions and others contained in this manual to prevent injury due to accidental contact with flying material thrown by flails.
  - a. Keep bystanders away from work area.
  - b. Keep shield in place and in good condition.



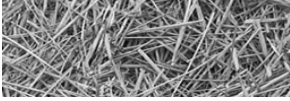
- c. Watch out for and avoid any object that might interfere with the proper operation of the machine.
  - d. Replace missing or damaged flails.
- Power takeoff shafts must be locked in place with protective P.T.O. shields in place.
  - Keep hands, feet and clothing away from power driven parts.
  - Never leave tractor controls unattended while the engine is running.
  - Never allow riders on the machine at any time.
  - Be sure the tractor operator is the only person riding on the tractor.
  - Exercise extreme care when operating on rough and/or steep terrain. Avoid operation on terrain which is excessively rough or steep.
  - Make sure your tractor P.T.O. speed never exceeds 1000 rpm.
  - Always stand to the side of the loader when moving transport pins. **Never stand under the loader unless the pins are installed in the upper holes on both sides.** Never force pins out of position, when the loader is fully raised pins can be moved easily.

## **DURING SERVICE & MAINTENANCE**

- Before working on or near the 2660/2665 BALEBUSTER for any reason, including servicing, cleaning, unplugging or inspecting machine, use normal shut-down procedures unless instructed differently in this manual.
- Never work on or near 2660/2665 BALEBUSTER unless engine is shut off and flails stopped.
- Check periodically and tighten any loose bolts or connections.
- Use only replacement parts that are recommended by DuraTech Industries.
- If it is necessary to operate the tractor engine indoors for more than a few seconds, be sure to provide enough ventilation to remove the tractor exhaust fumes.
- Hydraulic fluid escaping under pressure can be invisible and have enough force to penetrate the skin. When searching for a suspected leak, use a piece of wood or cardboard rather than your hands. If injured, seek medical attention immediately to prevent serious infection or reaction.
- Relieve all pressure in the hydraulic system before disconnecting the hose or performing other work on the system. Make sure all connections are tight and the hose is in good condition before applying pressure to the system.

## **1.6 Towing/road transport**

- Use good judgment and drive slowly over rough or uneven terrain.
- Be sure tractor brakes are properly adjusted and foot pedals are locked together.
- When preparing implement for transport, always use loader transport pins to secure bale loader in raised position. **Do not remove transport pins until hydraulic hoses have been charged and cylinder is fully extended.** Never force pins out of position, when the loader is fully raised pins can be moved easily.
- Check your state laws regarding the use of lights, slow moving vehicle signs, safety chain and other possible requirements.

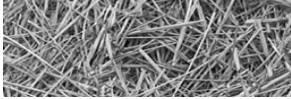


## Section 2: Dealer preparation

### 2.1 Pre-delivery inspection

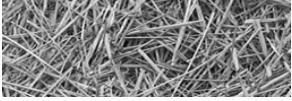
**INSTRUCTIONS:** Before delivering the machine, check the following items carefully and make corrections when necessary. Place an “X” in the box after each item has been checked and found to be acceptable.

- Check machine for missing items or damage in transit.
- Check for loose bolts or set screws.
- Check all hydraulics components for leaks or damage.
- Check oil level in chain case. (fill with hydraulic oil)
- Check lug bolts for tightness, torque to 85 to 90 Ft. lbs.
- Check for loose flail bolts, torque to 156 Ft lbs. (21.5 kg-m)
- Check tires for proper air pressure
- Check condition of tire rims.
- Check machine for proper lubrication.
- Check all chains for proper adjustment.
- Check all shields for installation and condition.
- Check condition of all decals.
- Check all phases of operation.

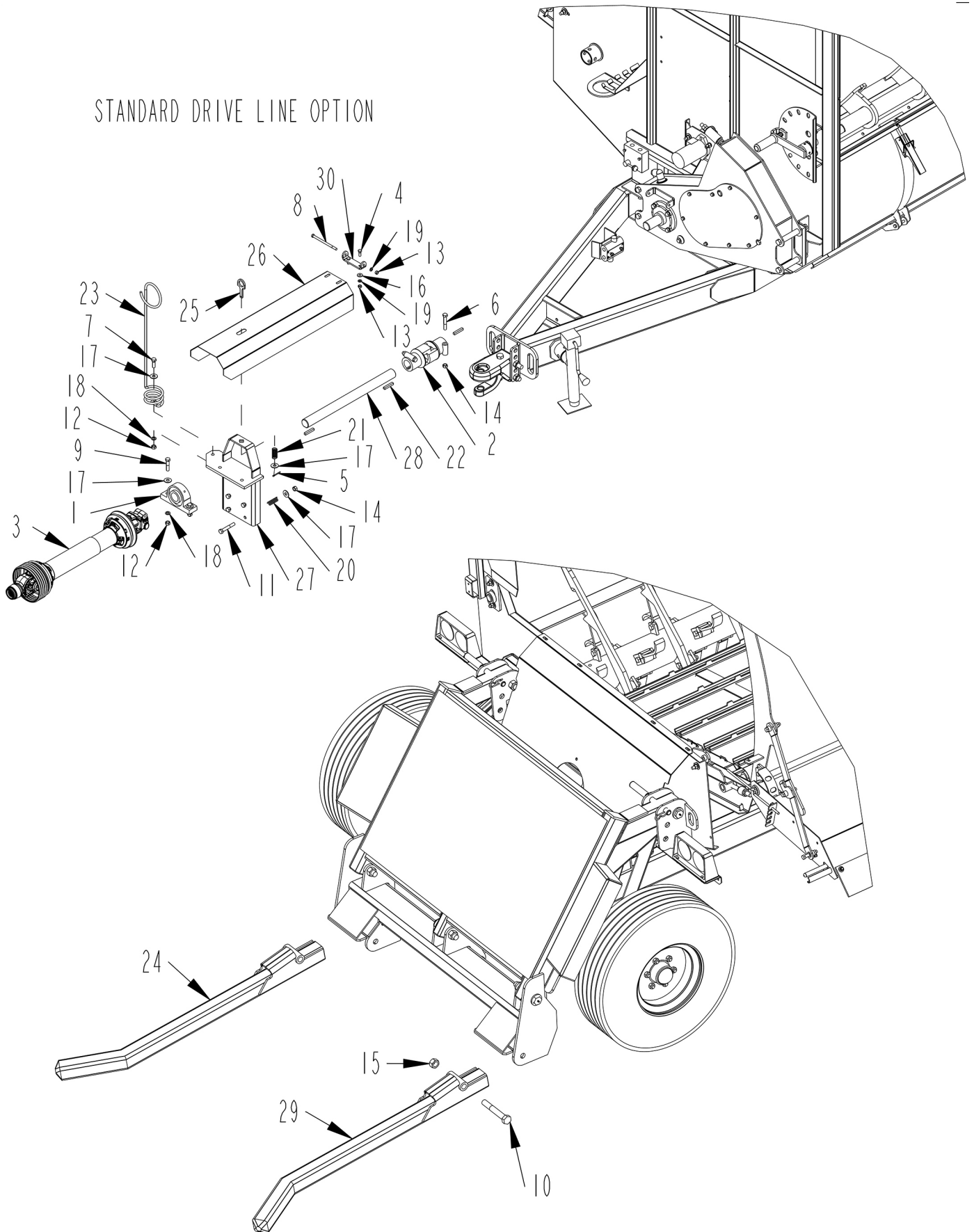


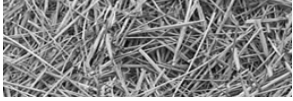
## 2.2 Shipping list and illustration for the 2660/2665 BALEBUSTER

ITEM	PART	QTY.	PART DESCRIPTION
1	2000514	1	BRG\PB\1-3/4\2BOLT\MALLEABLE
2	3600453	1	JOINT\44\1-3/4BORE\ASSY
3	3600459	1	PTO\252-21797\44R
4	4800003	38	BOLT\HEX\3/8X1
5	4800044	1	PIN\COT\5/32X1-1/2
6	4800068	3	BOLT\HEX\1/2X3
7	48000822	1	BOLT\HEX\1/2X1-1/2
8	4800210	1	BOLT\HEX\3/8X6
9	4800251	2	BOLT\HEX\1/2X2-1/4\NC
10	4800471	2	BOLT\HEX\1X7\NC
11	4800592	4	BOLT\HEX\1/2X3-1/4
12	4900001	45	NUT\HEX\1/2\NC
13	4900002	36	NUT\HEX\3/8\NC
14	4900014	18	NUT\TPLCK\1/2\NC
15	4900127	8	NUT\TPLCK\1\NC
16	5000001	31	WASH\FLAT\3/8
17	5000004	51	WASH\FLAT\1/2
18	5000006	53	WASH\LOCK\1/2
19	5000019	44	WASH\LOCK\3/8
20	6100028	4	2-1/4 COMP SPR.125 X .725
21	6100031	4	SPRING\COMP\.072W\25/32OD
22	6200020	3	KEY\SQ\3/8X2-1/4\HARDEND
23	7500170	1	HOSE MINDER
24	8101033	1	TINE\SQ\LEFTHAND
25	8101071	1	LATCH\SHLD
26	8101072	1	SHLD\PTO
27	8101073	1	BRKT\BRG\PTO\2650
28	8101074	1	SHFT\DRV\PTO
29	8101075	1	TINE\SQ\RIGHTHAND
30	8101076	1	MNT\SHLD\DRV



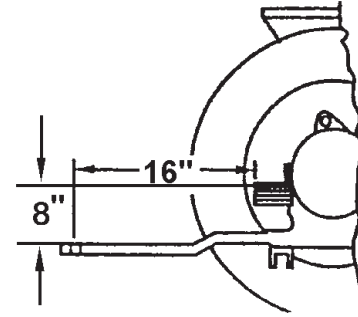
STANDARD DRIVE LINE OPTION





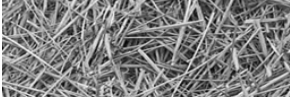
## 2.3 Assembly required

1. Adjust the tractor drawbar so that the distance from the end of the P.T.O. shaft on the tractor to the center of the drawbar hitch pin hole should be 16" (41 cm.), and the height for the top of the centerline of the P.T.O. should be 8" Refer to figure at right.
2. Hitch the 2660/2665 BALEBUSTER to the tractor drawbar. Adjust the hitch so machine is parallel with ground.
3. The hitch pin should be sized to prevent excessive movement, and should extend through all components of the hitch. The pin should be secured with a hairpin clip or suitable device to prevent the loss of the pin.
4. Adjust the hitch so the machine will be parallel with the ground. Hitch the 2660/2665 BALEBUSTER to the tractor drawbar.
5. Raise the jack, pull the lock pin and store in the transport position.
6. Connect the two hydraulic hoses from the hydraulic cylinder to one set of hydraulic couplers on the tractor. Connect the two hydraulic hoses from the bale conveyor speed valve to the second set of hydraulic couplers on the tractor.
7. Extend the loader hydraulic cylinder and hold the loader in the fully raised position. Remove the loader transport pin and place them in the storage position, (the lowest hole in the bracket). Retract the loader hydraulic cylinder completely, so the loader is in the lowest position.

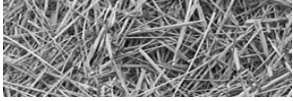


**NOTE:** Always stand to the side of the loader when moving the transport pins.

8. Mount tines #8100033 and #8101075 in the outer mounting brackets, this is the standard position. For small bales, use the inner brackets, and for the large bales use the outer brackets. Bolt in place using (2) 1x7 bolts #4800471 and lock nuts #4900127. See illustration on page 13.
9. Bolt Bearings Bracket #8101073 to mainframe with (4) ½ x 3-1/4 bolts #4800592, flat washer, spring #6100031 & lock nuts. Compress spring to 2" length.



10. Loosely assemble bearing #2000514 (with lock collar forward), on bracket using (4)  $\frac{1}{2}$  x 2-1/4 bolts #4800251, with (4) flat washers, lock washers, and nuts.
11. Slip drive shaft #8101074 thru bearing. Mount U-Joint #3600459 on drive shaft and chain case shaft using (2)  $\frac{3}{8}$  x 2-1/4 keys #6200020 and set  $\frac{3}{8}$  set screws #4800356. Clamp U-Joint on shaft with (2)  $\frac{1}{2}$  x 3 bolts #4800068, and lock nuts.
12. Tighten bearing and lock collar assembled in step 10 at this time.
13. Install drive shaft shield latch #8101072, spring #6100031,  $\frac{5}{32}$  x 1-1/2 cotter pin #4800044, and  $\frac{1}{2}$  flat washer. See illustration on page 13.
14. Loosely assembly drive shaft shield #8101072 and mounting bracket #8101076, using (2)  $\frac{3}{8}$  x 1 bolts #4800003 flat washer lock washers and nuts.
15. Bolt drive shield assembly to chain case, with (1)  $\frac{3}{8}$  x 6 bolt #4800210, and a lock nut. Shield must hinge freely, See illustration on page 13.
16. Lower shield over bearing stand. Tighten bolts assembled in step 14.
17. Mount P.T.O. shaft #3600459 and hardened key #6200020 on shaft #8101074 and lock set screws and tighten  $\frac{1}{2}$  x 3 bolt #4800068 and lock nut.
18. Attach the P.T.O. shaft to the tractor P.T.O. shaft. Depress coupling and slide the coupling onto the splined shaft. Make sure the spring loaded safety catch is properly seated.
19. Bolt hose minders to #7500170 to Bearing Bracket use, (1)  $\frac{1}{2}$ x1-1/2 bolts, flatwasher, lockwasher, nut.
20. Pull deflector and rack assembly out into operating position.
21. If required, install safety chain. Check local regulations regarding safety chain requirements.
22. Follow lubrication instructions found on pages 34-36 **before** use.
23. This machine is set up to operate on 1000 1-3/8" only!



## Section 3: Operation

To insure long life and economical operation, we highly recommend the operator of the 2660/2665 BALEBUSTER be thoroughly instructed in the maintenance and operation of the machine. There is no substitute for a sound preventative maintenance program and a well trained operator.

Prior to starting the engine of the tractor, we recommend the operator make a visual inspection of the unit. This can be done as the lubrication is being carried out. Any items that are worn, broken, missing or needing adjustment must be serviced accordingly before operating the 2660/2665 BALEBUSTER.

### 3.1 Pre-starting inspection instructions



**WARNING:** Before inspecting the machine, use the normal shut-down procedure on page 17.

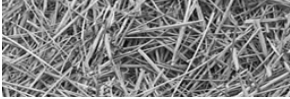
Check the following:

- Hydraulic components for leaks or damage.



**WARNING:** Hydraulic fluid escaping under pressure can be almost invisible and can have sufficient force to penetrate the skin. When searching for suspected leaks, use a piece of wood or cardboard rather than your hands. If injured, seek medical attention immediately to prevent serious infection or reaction.

- Check for loose bolts, worn or broken parts.
- Lug nuts for tightness.
- Condition of tire rims.
- Tires for proper air pressure. (40 PSI or 2.76 Bar)
- Installation and condition of flails.
- Rotor for twine build-up.
- Chains and belts for proper tension, and condition.
- Installation and condition of shields.
- Installation of slow moving vehicle (SMV) sign
- Condition of decals.
- Condition of flails and for loose flail anchor bolts. Torque to 156 Ft lbs. (21.5 kg-m)



## 3.2 Normal shutdown procedure

For your safety and the safety of others, you must use the following normal shut-down procedure before leaving the tractor controls unattended for any reason, including servicing, cleaning, or inspecting the 2660/2665 BALEBUSTER. A variation of the following procedure may be used if so instructed within this manual or your tractor manual or if an extreme emergency requires it.

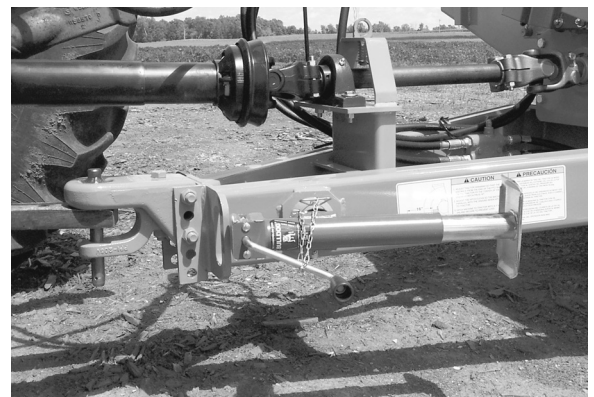
- a. Disengage P.T.O..
- b. Lower machine to ground level.
- c. Place transmission in park or set park brake.
- d. Shut off engine and remove key.
- e. Wait for all movement to stop.

## 3.3 Adjustments

### 3.3.1 Hitch Adjustment

The hitch is adjustable so that the machine is parallel to the ground when attached to the tractor drawbar. This is accomplished by removing the two mounting bolts and reinstalling them with the hitch at the proper height. The distance from the end of the P.T.O. shaft on the tractor to the center of the drawbar hitch pin hole should be 16” (41 cm.), and the height from the top of the drawbar to the centerline of the P.T.O, should be 8”. Refer to page 27

The hitch pin should be of proper size to prevent movement and length to extend through all components of the hitch. The pin should be secured with a hairpin clip or suitable device to prevent the loss of the pin.



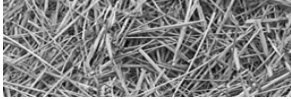
### 3.3.2 P.T.O. Shield



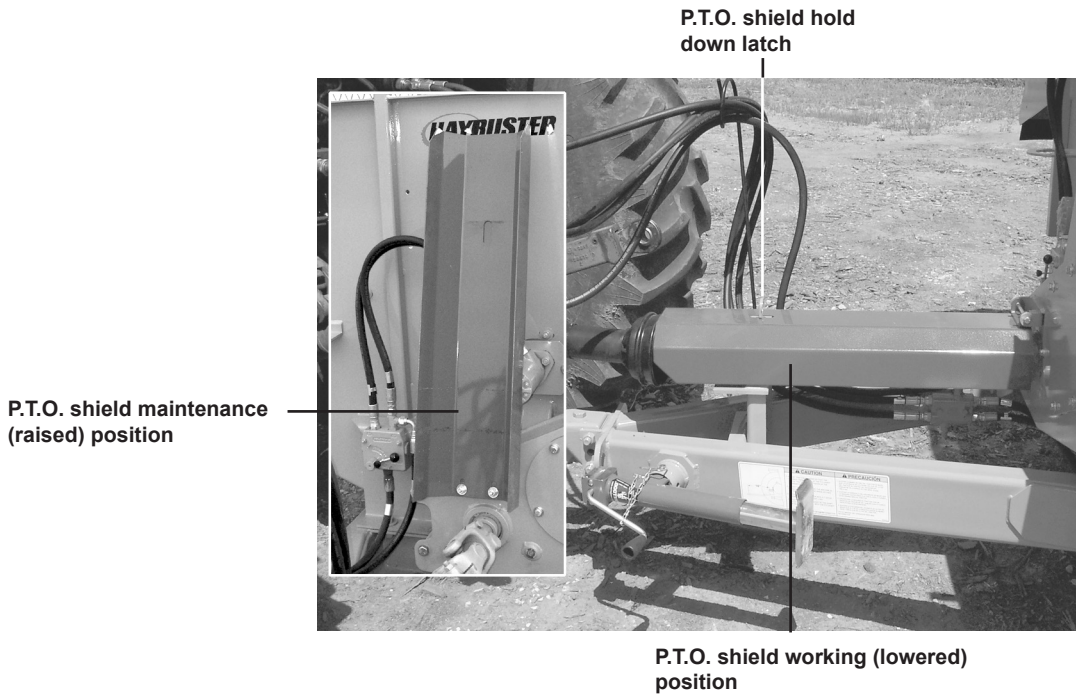
**WARNING:** Before lifting the P.T.O. shield be sure and follow the normal shut down procedure. Be certain that the tractor is shut off and all rotating components of the machine have come to a complete stop before lifting shield. Loose clothing is discouraged, and long hair should be restrained whenever working on P.T.O. shafts.

To raise the P.T.O. shield, unhook the hold-down straps near the front of the shield and lift the shield. It should pivot freely. If it does not pivot freely look for build up of debris or other obstructions at the pivot point. Do not force the shield, as damage to the shield may occur. Once the shield is in the upright position it should automatically lock in the upright position.

To lower the shield, pull the locking pin to release the shield and lower it into working position. Once the shield is lowered hook the hold-down straps.



**figure 3.1**  
 P.T.O. shield, working  
 (lowered) position,  
 latched maintenance  
 (raised) position.

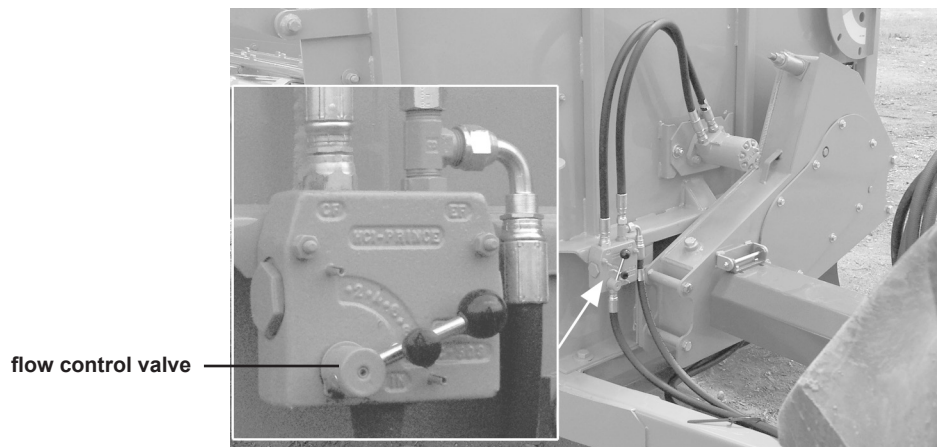


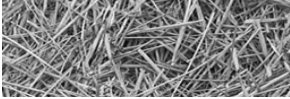
### 3.3.3 Conveyor Speed Control

Moving the lever on the conveyor speed control valve counterclockwise will slow the conveyor and make a finer product. Moving the lever clockwise will speed up the conveyor and make a coarser product.

For tractors with PFC type hydraulic systems, this valve should be set in the full open position (clockwise rotation). Conveyor speed can then be controlled directly from the tractor controls.

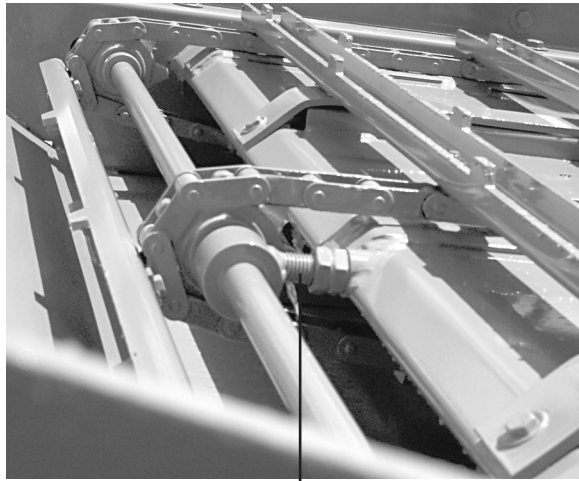
**figure 3.2**  
 position of the flow  
 control valve





### 3.3.4 Conveyor Chain Adjustment

The three chain tensioning bolts should be adjusted to allow lifting the slats 1" to 1-1/2" above conveyor deck. These bolts are located, on the front of the conveyor, at the center, and on the rear. Bolts must be adjusted evenly to prevent bowing the shaft.



center conveyor chain adjustment bolt

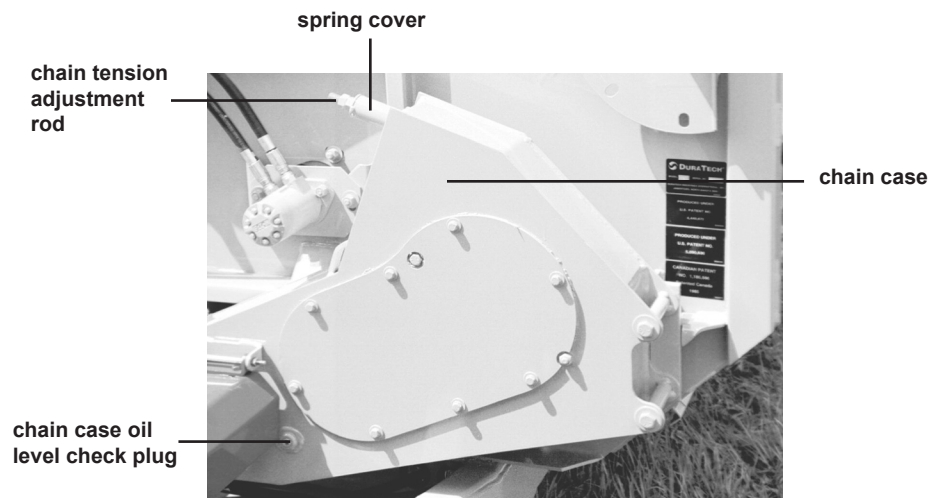


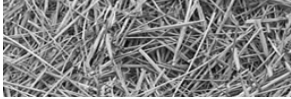
left conveyor chain adjustment bolt

### 3.3.5 Chain Case Adjustments.

It is normal for the chain to stretch. A spring-loaded idler sprocket maintains Chain tension. Adjusting the rod that protrudes through the top of the chain case changes chain tension. Chain tension can be checked by measuring the gap between the spring cover and the chain case. The correct dimension is 1/8in +/- 1/16in.

The chain case was filled with hydraulic oil when assembled, (10-weight motor oil can be used.) To check oil level, remove the plug on the front of the chain case. The oil level is within 1/2in of the opening.





### 3.3.6 Slugbar Adjustment

Exposing, less flail will create a finer cut and use less horsepower, while exposing more flail will produce a coarser cut.

This is accomplished by rotating the slugbar adjustment handle. Rotating the handle counterclockwise will expose more flail, clockwise will expose less flail. To rotate the handle, squeeze the lever to release the lock and rotate the handle to the desired position, and release the lever. Be sure that the lever is seated in one of the adjustment slots to ensure that slugbars stay properly adjusted.

With the handle rotated fully clockwise the will expose the least amount of flail (position 1).

Position	Approx. Flail Exposed
1	1"
2	1-1/8"
3	1-1/4"
4	1- 3/8"
5	1-1/2"
6	1-9/16"
7	1-5/8"
8	1-11/16"
9	1-3/4"



Positions 1 through 3 are for grinding hay. Positions 4 and-5 should only be used when spreading Dry Straw. **(DO NOT, use positions 4 and 5 if material is wet, has high moisture content or is frozen.)**

### 3.3.7 Clean Out Door



**WARNING:** Before opening the clean out door, be sure and follow the normal shut down procedure. Be certain that the tractor is shut off and all rotating components of the machine have come to a complete stop before opening clean out door.

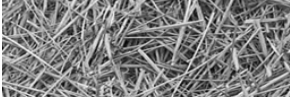
The clean out door allows for easy access to the rotor for flail changes and twine removal. To open the door remove the lynch pins and release the latches. Lift the latch hooks and open the door.

To close the door, hook the latch hooks and close the handles. This should draw the door in tight. If the door is loose or can not be closed, check for obstructions. Hooks can be adjusted by screwing them in or out of the latch. Once the door is closed, replace the lynch pins.

clean out door in the closed position



clean out door latches



### 3.3.8 Flails

Flails must be free to rotate about the bushings on the rotor. The bushings must not rotate. The bushings are held secure by tightening the bolts which squeeze the tabs against the bushing. Bolts should be torqued to 156 Ft lbs. (21.5 kg-m)

flail tightening bolt

rotor

flail



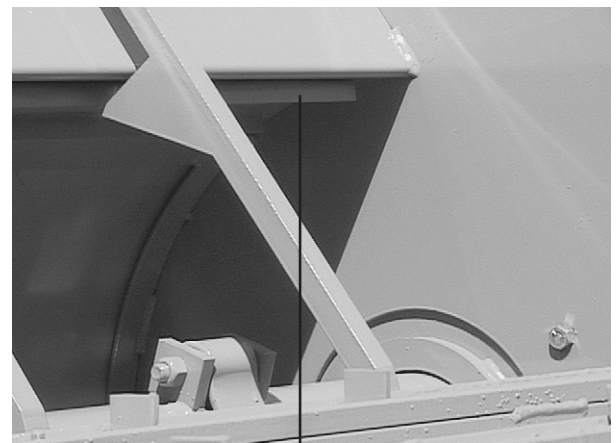
### 3.3.9 Stripper Plate

#### Stripper Plate for the 2660

Adding a stripper plate will produce a finer cut and removing plates will produce a courser cut.

For a finer cut, one or two additional stripper plates can be added. See pages 132-133 "Stripper Bar Installation" for installation information.

In applications such as land reclamation, where a very

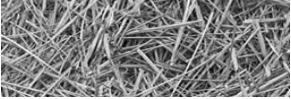


stripper plate

#### Stripper Plate for the 2665

The three standard stripper plates will produce a finer cut, and removing plates will produce a courser cut.

In applications such as land reclamation, where a very course cut is desired, all stripper plates may be removed.

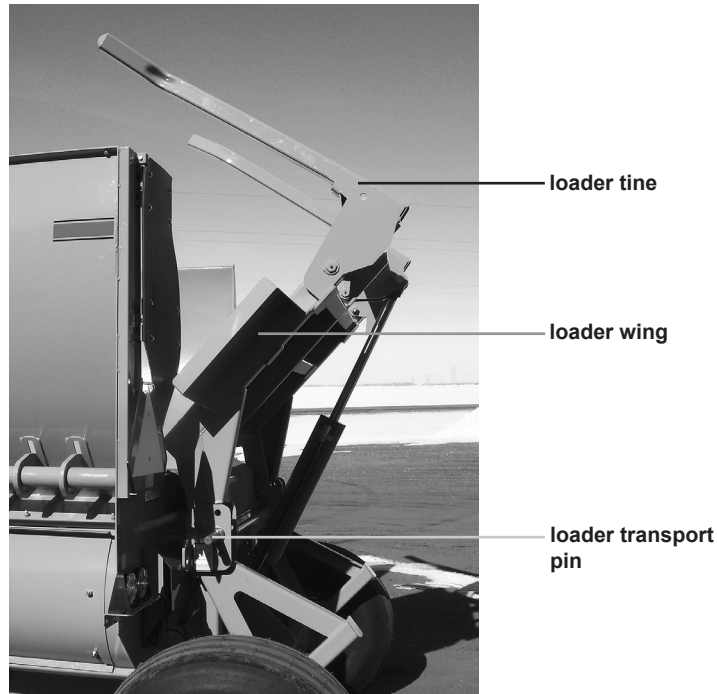


### 3.3.10 Loader

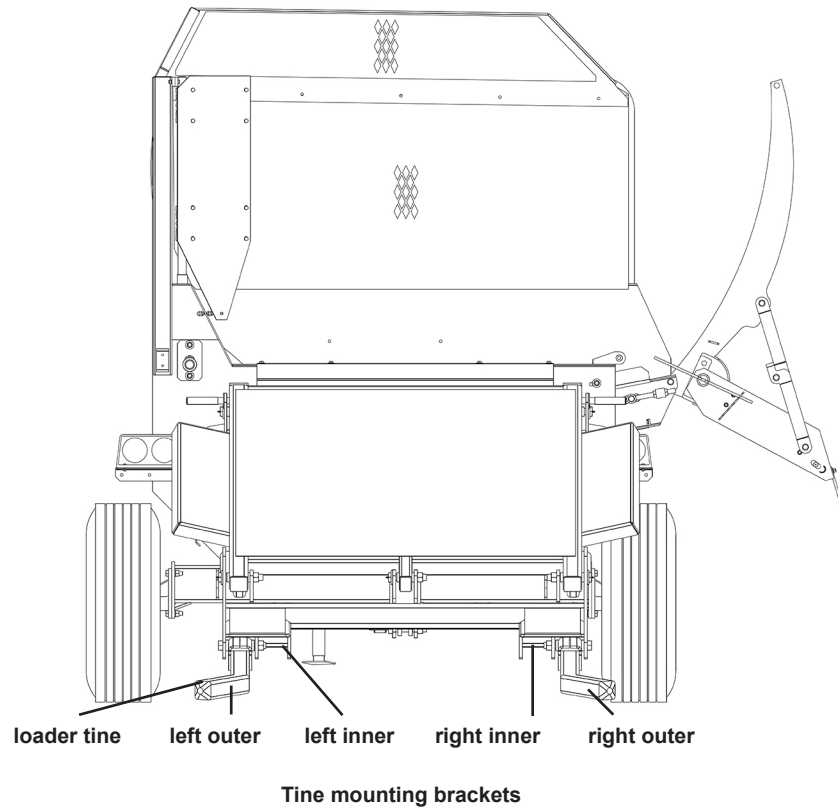
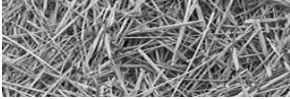


**WARNING:** Loader tines may swing down unexpectedly as they drop over center. They can move faster than you can react. Keep all bystanders away from the machine while loader is raised.

figure 3.3  
Loader Tines



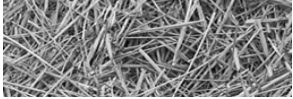
1. The loader has three settings for different size bales. For bales approximately 72" in diameter mount the loader tines in the outermost position. 60" bales require the loader tines to be positioned in the left outer slot and the right inner slot (left and right are determined while facing in the direction of travel). 48" bales require the tines to be positioned in the inner mounting slots (see page 23)
2. 48" bales use left inner and right inner mounting slots.  
60" bales use left inner and right outer mounting slots (standard).  
72" bales use left outer and right outer mounting slots.



3. These settings are accomplished by removing the pivot bolts and removing the tine. After the tine is reinstalled in the proper position, reinstall the pivot bolt and tighten. Be sure the bolt threads protrude through the entire nut so that the locking nut functions properly. Do not over tighten the pivot bolt, the tine should rotate freely about the pivot bolt.
4. The loader tines should pivot freely as the loader is raised and lowered. If the loader tines don't swing down into the loading position the bale will not load properly. With the loader fully raised the loader tines should swing down.



**CAUTION:** Watch for overhead hazards such as power lines.



### 3.3.11 Loader Transport Pin



**WARNING:** Never stand under loader when removing transport pins. Do not attempt to force pins out, with the loader fully raised they can be easily removed.

The loader transport pins can be inserted into three positions:

1. Upper hole: Holds the loader in the fully raised position for transport.
2. Middle hole: Holds the loader partly raised. This improves rear visibility and reduces wind drag during transportation
3. Lowest hole: Holds the loader transport pin in storage position.



loader transport pin in storage position

### 3.3.12 Hydraulic Cylinder and Valve

All cylinder and valve hose connections should be tight and leak free. If the area near a hose connection becomes oily or dirty repairs should be made to seal the leak. Hoses should be free of cracks or cuts to ensure safe operation. Cylinder seal kits are available from your dealer to repair a leaky cylinder. Pin connections should be free of excessive wear. If pins become worn they should be replaced. Also check yokes and mounts for cracks and wear.

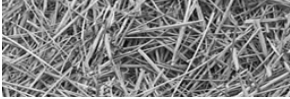


**WARNING:** Hydraulic fluid escaping under pressure can be almost invisible and can have sufficient force to penetrate the skin. When searching for suspected leaks, use a piece of wood or cardboard rather than your hands. If injured seek qualified medical attention immediately to prevent serious infection or reaction.

### 3.3.13 Tires & Rims

Tires should be inflated to 40 PSI and should be free of cuts or cracks. There should also be adequate tread and no visible cords, wires or tread separation. Tires must also be of proper load rating, speed rating and size.

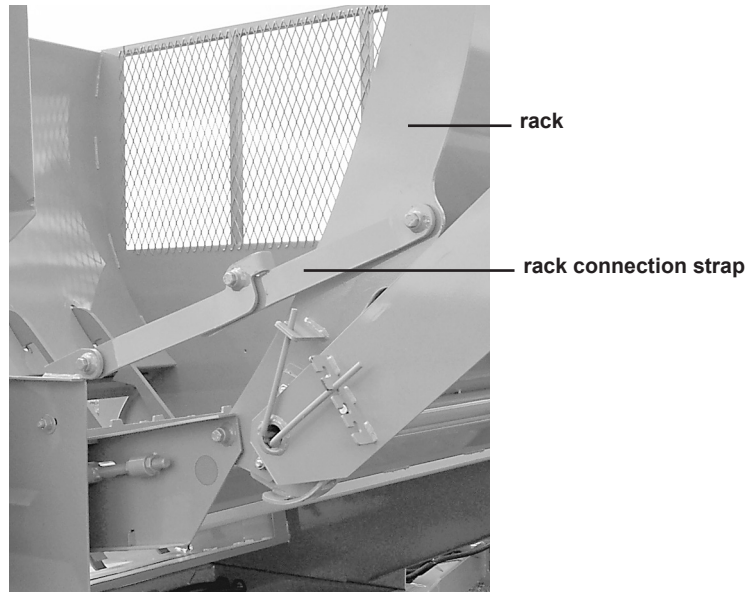
Rims must be free of cracks and rust pitting. Lug bolts must also be tight. Inspect the area around the lug bolts. If rust develops this is a sign of loose lug bolts. Check wheel bearings and seals, replace and grease as use requires.



### 3.3.14 Rack

The rack has two positions: transport and working. The rack should travel between the two positions freely under the operator's own power. All pivoting connections should be snug, but still allow the points to hinge freely. Inspect for cracked or excessively worn holes at the connections. The rack connection straps are designed to be self-folding and should not drop over center. If the straps become bent or do not function properly they should be replaced.

**figure 3.4**  
rack in the working  
position, rack  
connection straps



### 3.3.15 Jack

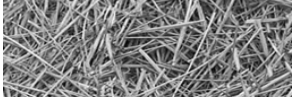
An adjustable jack is provided with the machine to support the hitch when the machine is disconnected from the tractor. The jack must only be used on firm, level ground or similar base to prevent it from sinking,

When unhooking the machine remove the jack pin and rotate the jack to the upright position and reinstall the pin. Crank the jack until the hitch is no longer supported by the drawbar of the tractor. The hitch pin can now be removed.



**WARNING:** Never use the jack without reinstalling the jack pin.

When hooking up the machine, install a proper hitch pin and secure it with a hairpin clip or comparable device, crank the jack until the foot of the jack is fully raised. Remove the jack, and place in transport position.

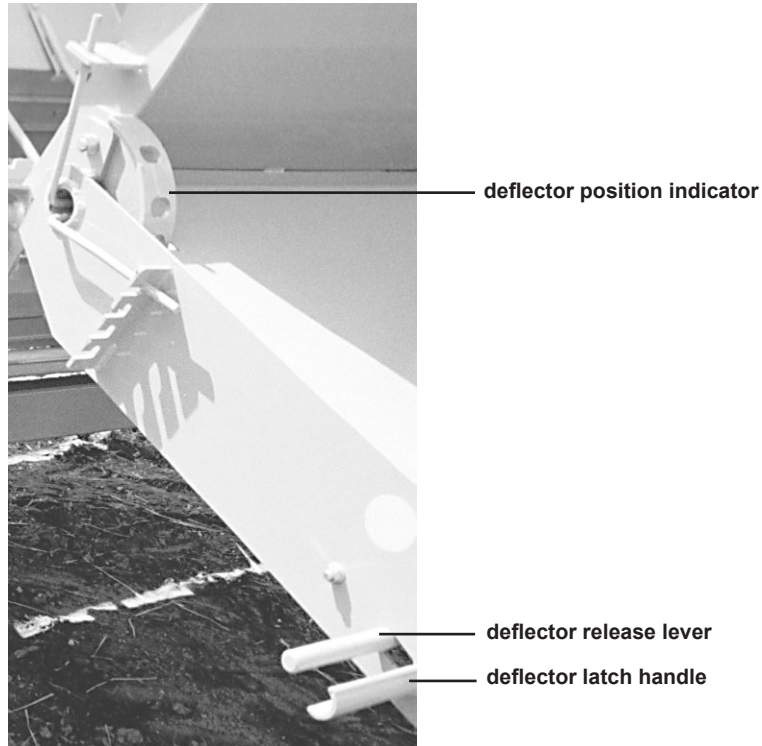


### 3.3.16 Changing distribution pattern

The deflector can be positioned for creating a windrow, spreading, bunkfeeding, or stockpiling. Lower the deflector for a narrower windrow and raise the deflector for a wider spread.

To change the position, pull the release lever, Rotate the deflector to the desired position and release the handle. A wider deflector belt (PN 8100819) is available for bunk feeding or additional material control.

**Figure 3.5**  
deflector adjustments-  
deflector release lever  
and deflector latch  
handle.



### 3.4 Hitching the 2660/2665 BALEBUSTER



**WARNING:** Do not operate the 2660/2665 BALEBUSTER unless the tractor complies with the following requirements:

1. Tractor has a minimum of 65 horsepower.
2. Tractor has rollover protective structure and seatbelts.
3. Tractor's hydraulic system has two-way valves, and a minimum flow of 12 GPM @ 1500 psi.
4. To assure adequate braking and steering control, the tractor must have a weight greater than or equal to the weight of the 2660/2665 BALEBUSTER and any bales it will transport.

To hitch the 2660/2665 BALEBUSTER to a tractor, perform the following steps:

1. Adjust the tractor drawbar so that the distance from the end of the P.T.O. shaft on the tractor to the center of the drawbar hitch pin hole should be 16" (41 cm.), and the height for the top of the centerline of the P.T.O. should be 8" Refer to Figure 3.7
2. Hitch the 2660/2665 BALEBUSTER to the tractor drawbar. Adjust the hitch so machine is parallel with ground.
3. The hitch pin should be sized to prevent excessive movement, and should extend through all components of the hitch. The pin should be secured with a hairpin clip or suitable device to prevent the loss of the pin.
4. Raise the jack. Pull the lock pin and store in the transport position.
5. Attach the P.T.O. shaft to the tractor P.T.O. shaft. Depress coupling and slide the coupling onto the splined shaft. Make sure the spring loaded safety catch is properly seated.
6. This machine is set up to operate on 1000 rpm only!
7. If required, install the safety chain. Check local regulations regarding safety chain requirements.
8. Connect the two hydraulic hoses from the hydraulic cylinder to one set of hydraulic couplers on the tractor. Connect the two hydraulic hoses from the bale conveyor speed valve to the second set of hydraulic couplers on the tractor.
9. If equipped with optional grain tank, connect the two hydraulic hoses from the grain tank to the third set of hydraulic couplers on the tractor.

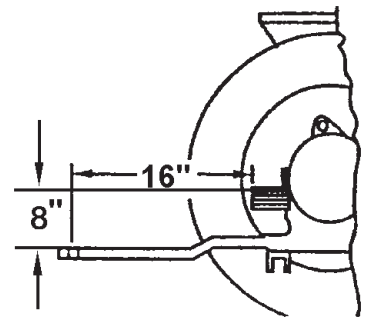
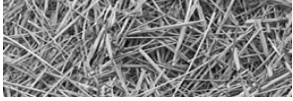


figure 3.7  
safe P.T.O. distance



### 3.5 Unhitching the 2660/2665 BALEBUSTER

To unhitch the 2660/2665 BALEBUSTER, perform the following steps:

1. Follow normal shut-down procedure.
2. Lower jack and secure. Raise the tongue off of the tractor draw bar.
3. Detach the P.T.O. shaft from the tractor.
4. Cycle the hydraulic control levers to release any pressure in the hydraulic hoses.
5. Detach the hydraulic hoses.
6. Remove the safety chain, if installed.
7. Remove the hitch pin.

### 3.6 Starting the machine



**DANGER:** After making all necessary hook-ups to tractor, be sure rotor chamber is clear of any solid objects. Make sure any bystanders are away from the 2660/2665 BALEBUSTER before engaging P.T.O., conveyor or loader. Flying objects can cause serious injury or death. Stay clear of discharge side of machine unless operator has stopped tractor engine and machine has stopped rotating. Failure to follow these instructions may result in severe injury or death.

To start the machine, perform the following steps:

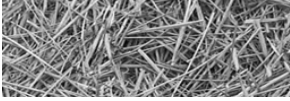
1. Unfold the rack into working position. Adjust the deflector to desired position.
2. Steps 3 through 5 are performed with the tractor at idle, and the operator at the tractors controls.
3. Engage the conveyor. Run the conveyor in forward and then in reverse. Check to be sure the conveyor is working properly before attempting to shread a bale.
4. Raise the loader, and remove transport pins.



**CAUTION:** Look out for overhead hazards such as power lines.



**WARNING:** Never stand under loader when removing transport pins. Do not attempt to force pins out, with the loader fully raised they can be easily removed.

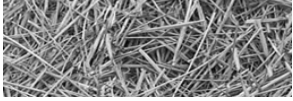


5. Engage the P.T.O..



**CAUTION:** Engaging the P.T.O. with the tractor engine speed above an idle may damage the drive line components and the tractor P.T.O..

6. Increase tractor engine speed until the P.T.O. speed reaches 1000 RPM. Listen for noise and watch for vibration. If necessary, follow the shut down procedure, and make repairs before attempting to shred any bales.
7. Run the machine and cycle the loader to warm up the machine before shredding bales.



### 3.7 Loading the bale

The bale conveyor must not be running when a bale is lifted into the shredding chamber. (*step3-5*), dropping bales on to the moving conveyor slats may bend slats.



**DANGER:** If it is necessary to transport a second bale over uneven terrain, make sure any bystanders are away from the 2660/2665 BALEBUSTER. Serious injury or death could result if the bale rolls off the loader main frame loader supports.

**STEP 1:** Lower the bale loader part way down so you can still see the end of the tine fork. Use the fork as a guide and back up to the first bale, with the bale loader in its lowest position, back up until the bale is loaded on the main frame loader supports

**STEP 2:** Slowly lift bale, until the flat end is firmly against the table. If you need to travel to the second bale, transport with the bale loader on the main frame supports, use the bale as a guide to line up the second bale.

**STEP 3-5:** Slowly lift bale into the shredding chamber. Continue lifting the bale loader until it stops. The correct position for shedding a single bale will help prevent spillage.

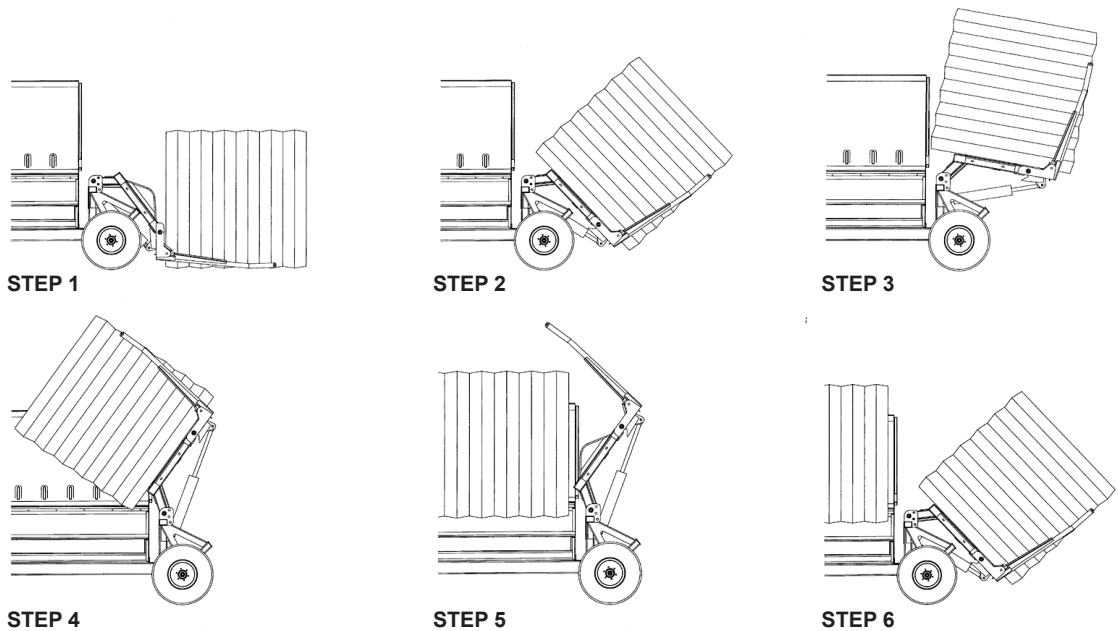


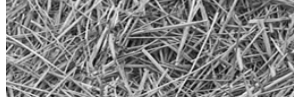
**NOTE:** If bale does not rotate forward the twine may be over the tine. Cut the twine at this time to prevent damage to the machine.

**STEP 6:** Load a second bale (if the first bale is on the main frame loader supports, use the bale as a guide to line up on the second bale). (If the first bale is in the shredding chamber use the conveyor and move the bale to the right so you can look past it on the left side). Back trailer until bale is loaded on the main frame loader supports. Slowly lift the bale off the ground keeping the weight of the bale on the main frame loader supports. This is the transport position for the second bale.

**STEP 7:** After the first bale is shredded, repeat steps, 3-5, loading and shredding the bale.

figure 3.6  
loading the bale





### 3.8 Shredding the bale



**CAUTION:** Avoid uneven terrain with bale loaded. Serious injury could result if machine is allowed to tip.



**NOTE:** Operating tractor at a P.T.O. speed of 1000 RPM enables the machine to do a better job of chopping forage and also keeps a minimum of twine buildup on rotor. Twine buildup should be kept to a minimum to reduce fire hazard.

**NOTE:** Always operate slat conveyor to rotate bale in direction indicated by arrow on front shield. Reverse direction only if bale is lodged or hesitates to turn.

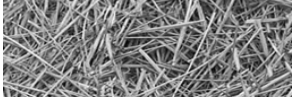


**DANGER:** If it is necessary to transport a second bale over uneven terrain, make sure any bystanders are away from the 2660/2665 BALEBUSTER. Serious injury or death could result if the bale rolls off the main frame loader supports.

With a bale loaded into the shredding chamber, perform the following steps:

1. If necessary, adjust the deflector to the desired position.
2. Position the 2660/2665 BALEBUSTER where you want to begin shredding the bale.
3. Engage the conveyor and move the bale to the right side of the machine. This will move the bale away from the rotor for startup.
4. Machine's hydraulic system performs two (2) functions. One function raises the bale lifter for loading bales into machine. The second function powers bale conveyor by means of a hydraulic motor. Decreasing speed allows flail knives to chop forage finer, increasing speed leaves forage coarser.
5. Engage the P.T.O., and increase tractor engine speed so that P.T.O. is at 1000 RPM.
6. Engage the bale conveyor, and check to see if bale is rotating in the proper direction. The proper direction of bale rotation is indicated by the bale rotation decal located on the front of the 2660/2665 BALEBUSTER; rotation is counter clockwise.





### 3.9 Twine Removal

To remove twine from the rotor open clean out door - refer to section 3.3.7. Using a hacksaw with a fine tooth blade is one method of cutting the twine and works with all types of twine.

figure 3.7  
removing twine from the  
rotor with a fine tooth  
hacksaw



### 3.10 Transporting the 2660/2665 BALEBUSTER

This machine is designed to fold for ease of transportation and storage. The rack and deflector assembly folds inside of bale chamber.



**DANGER:** Do not remove transport pins until the hydraulic hoses have been charged and the cylinder fully extended. Failure to follow these instructions may result in severe personal injury or death.



**WARNING:** Never stand under loader when removing transport pins. Do not attempt to force pins out, with the loader fully raised they can be easily removed.

To prepare the 2660/2665 BALEBUSTER for transport, perform the following steps:

1. Raise the loader and move the loader transport pins to the desired position. (Fully raised, partially raised) See section 3.3.11 “Loader Transport Pin” for more information.
2. Release the hydraulic pressure and lower the loader until it rests on the pins.
3. Pivot the deflector into the tub to insure eight feet four inches (8’4”) towing width.



### 3.11 Storing the 2660/2665 BALEBUSTER



**WARNING:** When preparing machine for storage, use normal shut-down procedure.

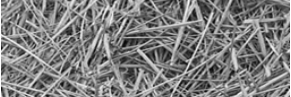
To prepare the 2660/2665 BALEBUSTER for storage, perform the following steps:

1. Clean all mud, dirt, grease and other foreign material from the exterior of the machine. Cut all twine off from around the rotor. Wash the complete machine. If washing the 2660/2665 BALEBUSTER with a high pressure washer, keep the nozzle away from the sealed bearings. To inhibit rusting repaint places where bare metal is exposed.
2. If equipped with the optional grain tank, clean out the tank and auger.
3. Place the jackstand in the down and in locked position. Block the rear axle up taking the weight off the tires, but do not deflate the tires. If possible, store the machine in a dry, protected place. If it is necessary to store the machine outside, cover it with waterproof canvas, plastic, or other suitable protective material.
4. Coat exposed lift cylinder rod with grease. Oil chains on conveyor. Lubricate thoroughly according to lubrication instructions. Repack wheel bearings.
5. Check the machine for any worn or broken parts. By ordering parts now, you will avoid delays when it is time to remove the machine from storage. When ordering parts always specify machine serial number and the part number of the replacement part. Part numbers can be found in the parts section of this manual.

### 3.12 Removing the 2660/2665 BALEBUSTER from storage

To remove the 2660/2665 BALEBUSTER from storage, perform the following steps:

1. Remove all protective coverings.
2. Remove blocking from under 2660/2665 BALEBUSTER. Check tire pressure.
3. Lubricate machine in accordance with lubrication instructions found in this manual.
4. Check all hydraulic hoses for deterioration and, if necessary, replace. Tighten any loose bolts, nuts and hydraulic fittings.
5. Follow pre-starting inspection instructions.



## Section 4: Lubrication

The operator should make a check of all grease fittings on the unit before beginning to operate it so as to become familiar with their location and the correct service schedule.



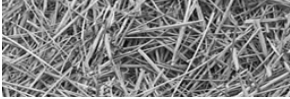
**WARNING:** Use normal shut-down procedure (page 17) before lubricating machine.

### 4.1 Lubrication

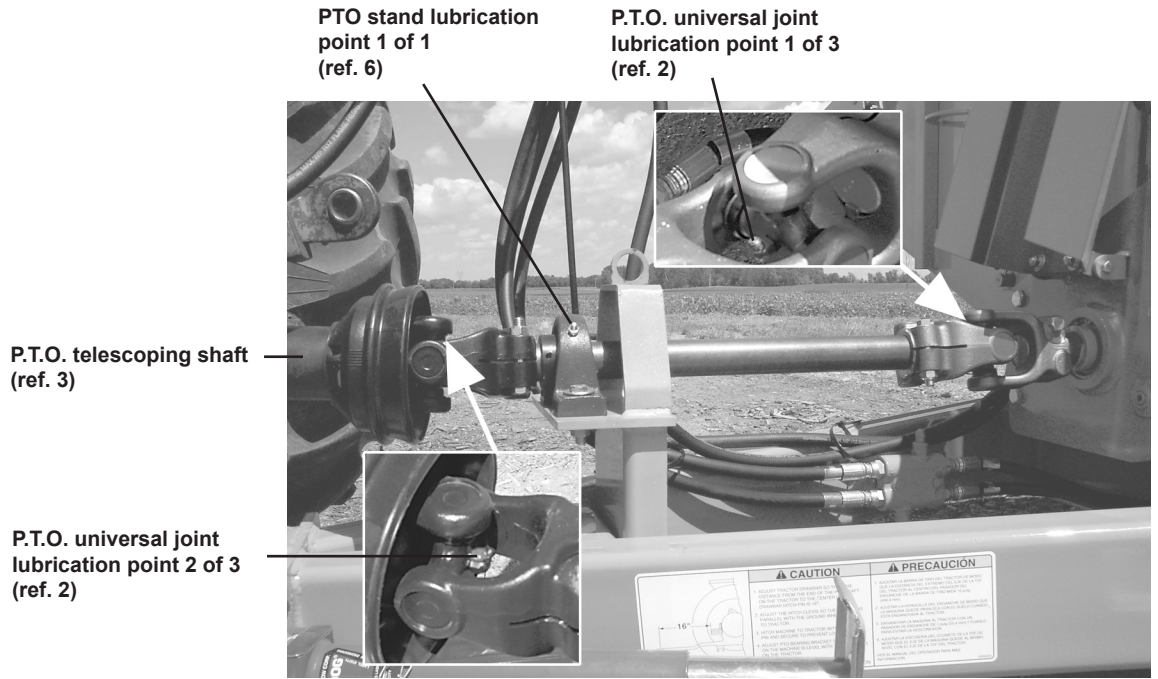
Use only a high quality, #2 multi-purpose grease when lubricating the unit. Make sure all fittings and the nozzle of the grease applicator are clean before applying the grease. If any grease fittings are missing, replace them immediately.

Machine has 17 points to lubricate with grease gun **every fifteen (15) hours** of operating time.

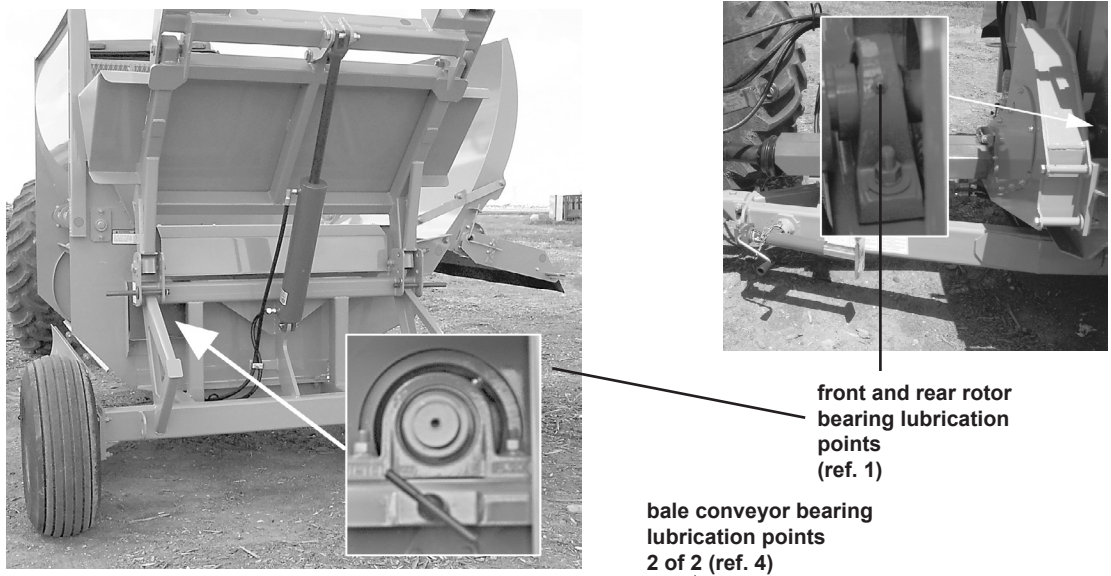
1. Rotor bearings - 2 places.
2. P.T.O. universal joints - 3 places.
- 2A. As many as seven (7) pumps of grease are required to purge all cross and bearing lube points with fresh grease.
3. Telescoping shafts - 1 place.
- 3A. Telescoping members require enough grease to maintain a smooth sliding action. When telescoping members become contaminated with dirty grease, they should be inspected and cleaned to insure smooth operation.
- 3B. Shield components should be lubed and inspected to insure all components are in working condition or are replaced if damaged. A properly maintained shield will inhibit dirt from contaminating telescoping members.
4. Bale conveyor - 2 places.
5. Check oil level in chain case every fifty (50) hours of operating time. (See section 3.3.5)
6. PTO stand (1)
7. Wheel bearings - repack annually.
8. Chain Case Bearings - 3 places.
9. Loader - 5 places.



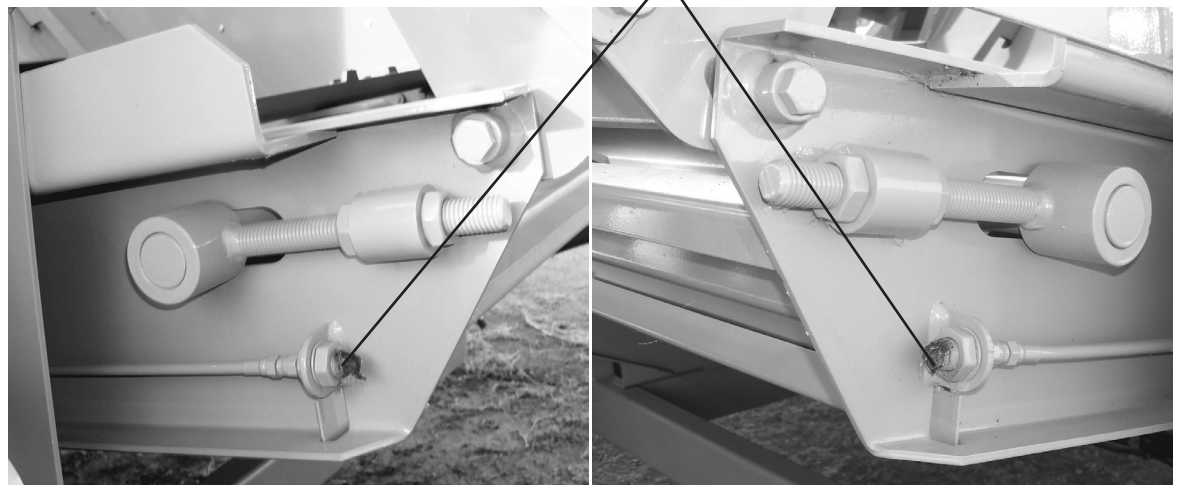
**figure 4.1**  
P.T.O. lubrication

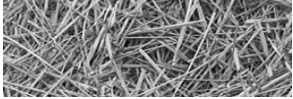


**figure 4.2**  
rotor bearing lubrication point

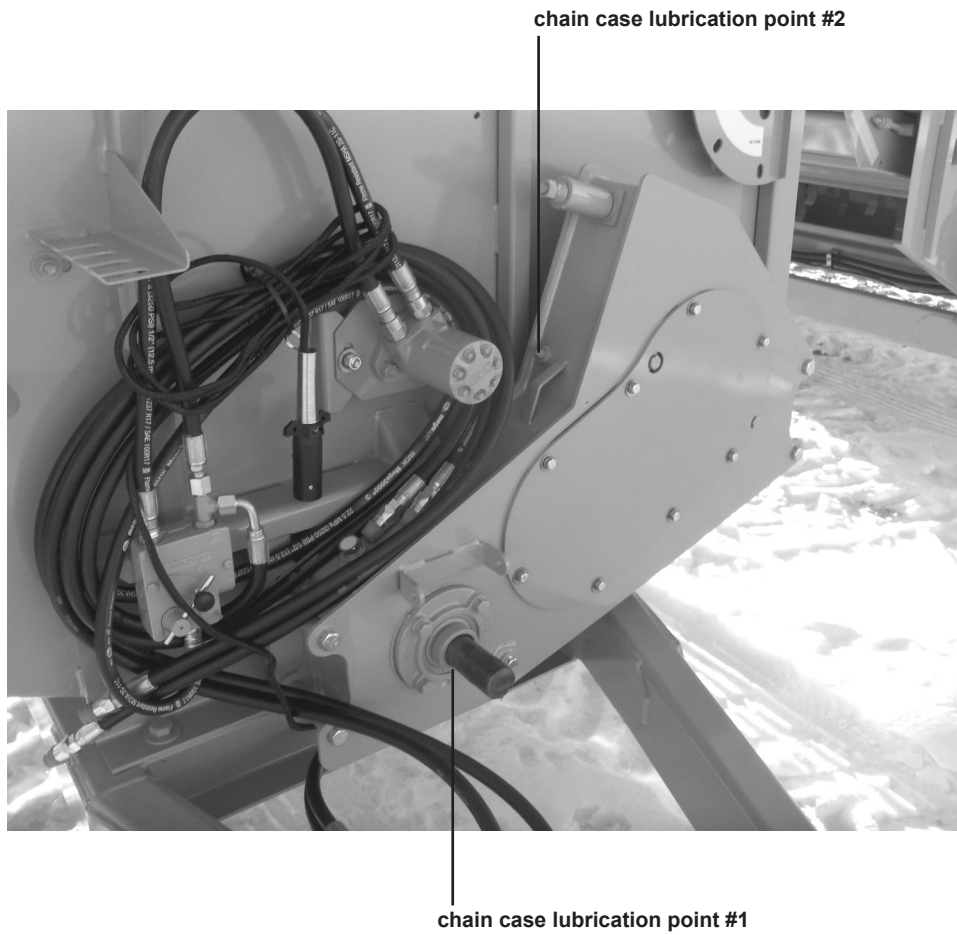


**figure 4.3**  
bale conveyor bearing lubrication point

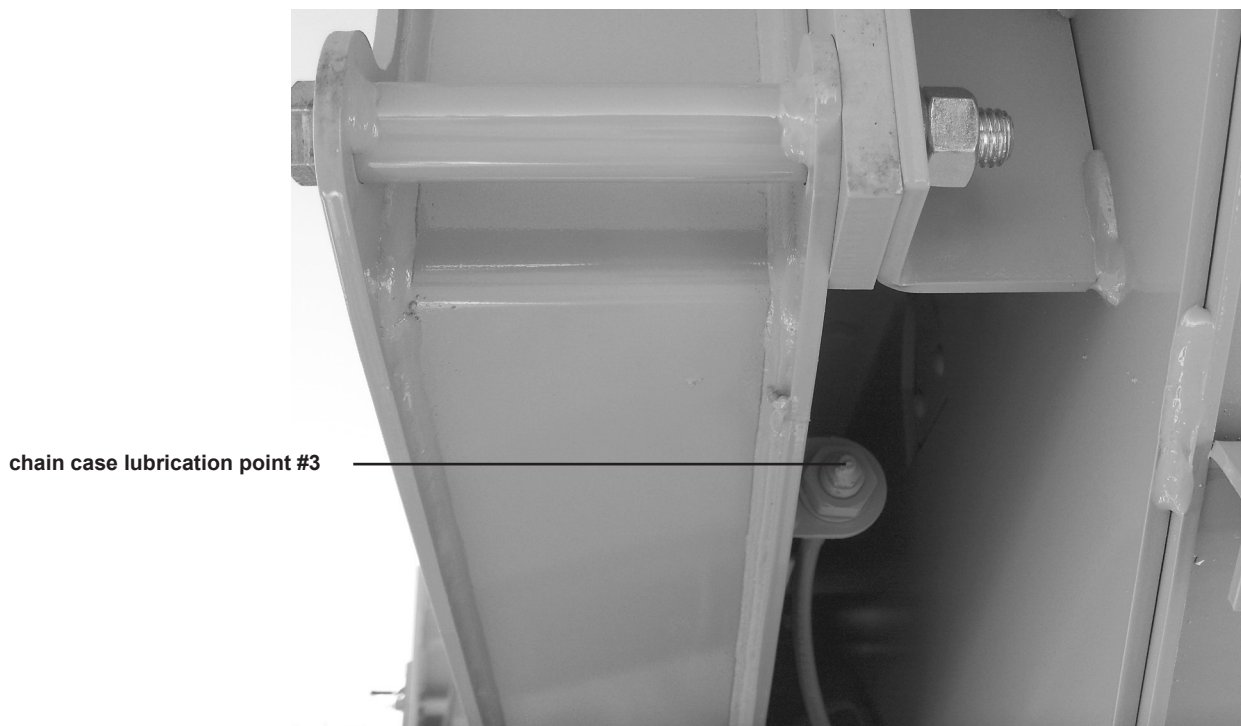


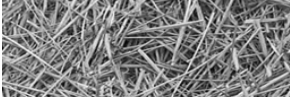


**figure 4.4**  
**chain case lubrication**



**figure 4.5**  
**chain case lubrication**





**figure 4.6**  
**roller chain lubrication**



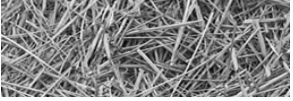
**roller chains- apply a  
graphite lubricant to  
roller chains after every  
15 hours of use**

**figure 4.7**  
**loader lubrication points #1**

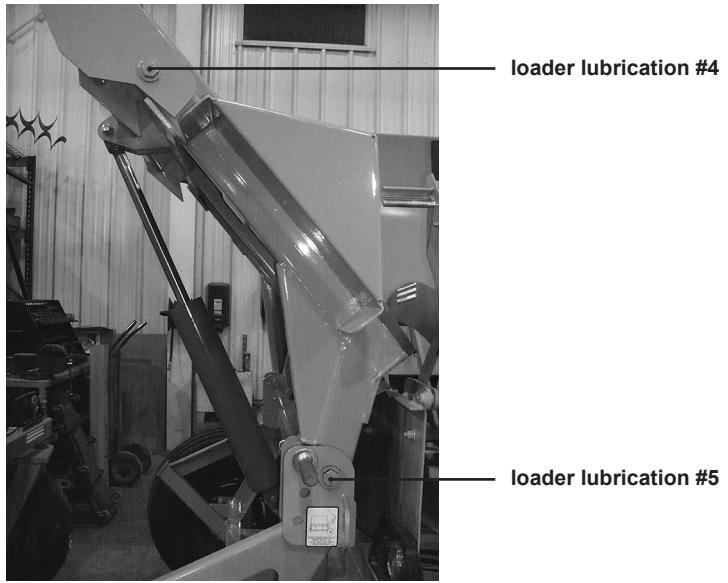


**loader lubrication #1**

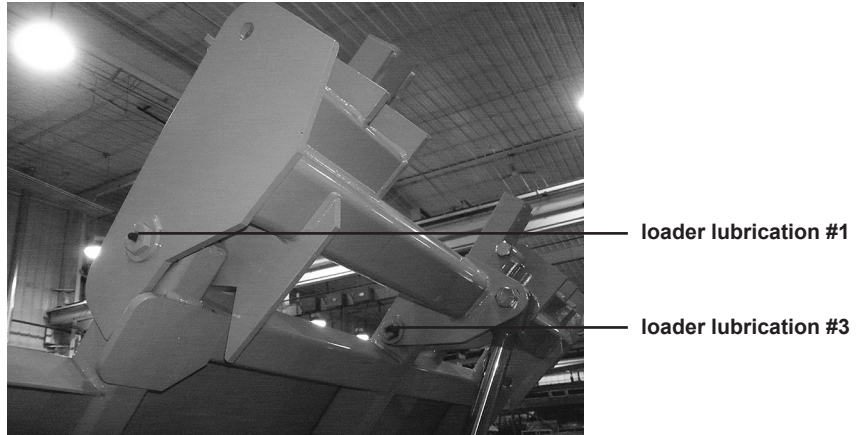
**loader lubrication #2**

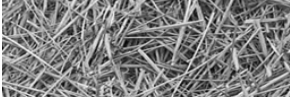


**figure 4.8**  
**loader lubrication points #2**



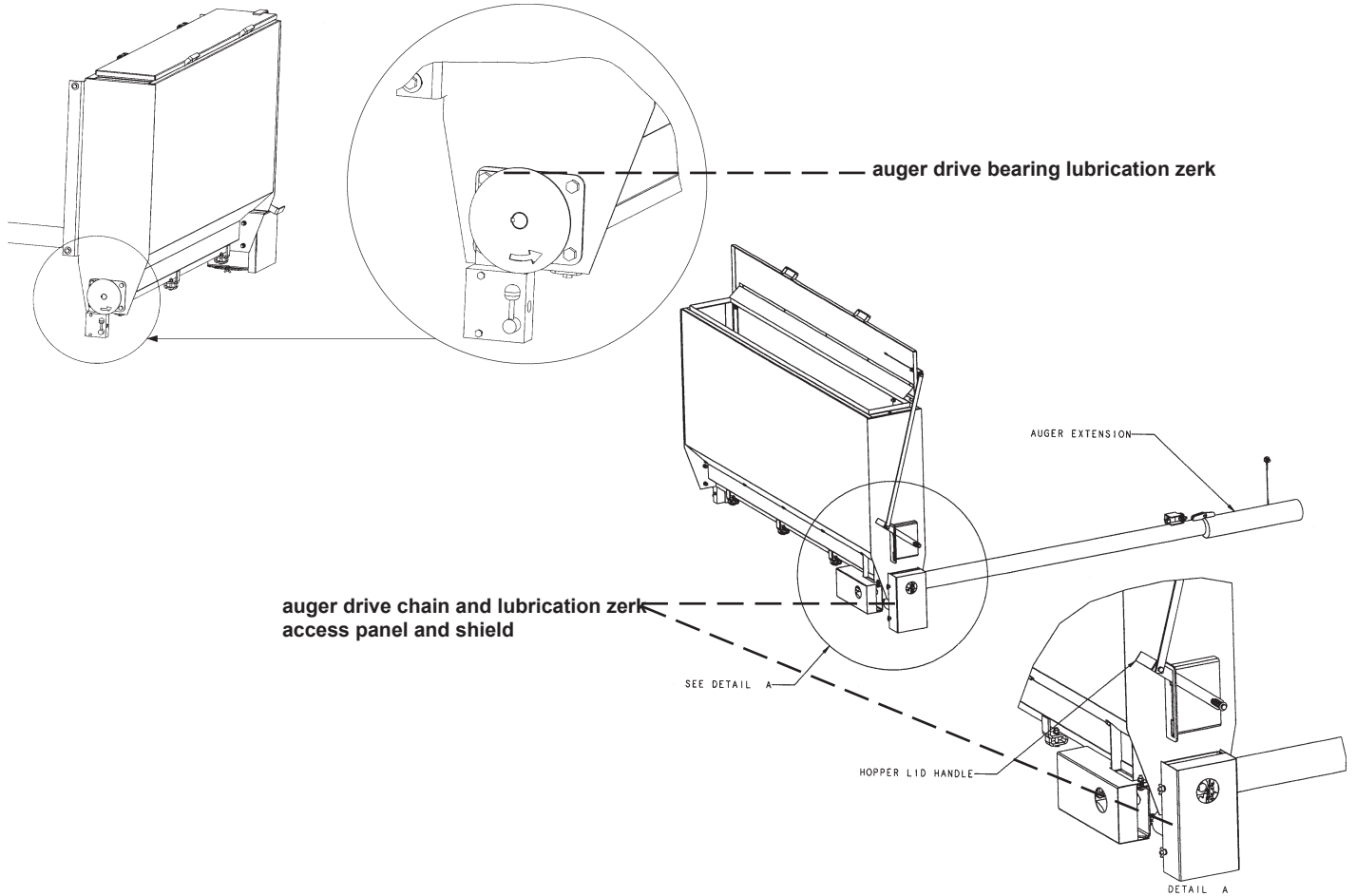
**figure 4.9**  
**loader lubrication points #3**





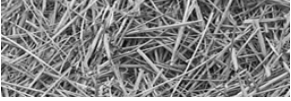
## 4.2 Grain tank (Option)

Lubricate the auger drive chain and auger bearings after every 15 hours of use.



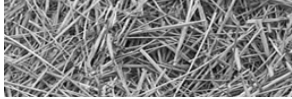
## 4.3 General appearance

Clean all mud, dirt, grease and other foreign material from the exterior of the machine. Cut all twine off the rotor. Wash the entire machine. If washing the 2660/2665 BALEBUSTER with a high-pressure washer, keep the nozzle away from the sealed bearings. Repaint places where bare metal is exposed.



## Section 5: Troubleshooting

<b>PROBLEM</b>	<b>CAUSE</b>	<b>REMEDY</b>
1. No Capacity	1. Bale turning too slow.	1. Open conveyor speed control valve.
2. Bale Does Not Turn	1. Bale lodged in feeder	1. Reverse rotation of slat conveyor.
3. Excessive Vibration	1. Build up of twine on rotor. 2. Broken flail. 3. Defective cylinder bearing. 4. Misaligned or worn PTO.	1. Remove all twine from rotor. 2. Replace flail. 3. Replace bearing. 4. Replace worn part or complete PTO.
4. Machine Will Not Lift Bale	1. Tractor hydraulic pressure too low. 2. Hydraulic oil leaking by piston in cylinder.	1. Check pressure. 2. Repair or replace hydraulic cylinder.
5. Forage Too Course	1. Conveyor speed too fast. 2. Slug bar set too low. 3. Stripper plate removed.	1. Decrease conveyor speed. 2. Raise slug bar to expose less flail. 3. Replace or add additional stripper plate.
6. Forage Too Fine	1. Conveyor speed too slow. 2. Slug bar set too high. 3. Extra stripper plate installed.	1. Increase conveyor speed. 2. Lower slug bar to expose more flail. 3. Remove one or all stripper plates.
7. Forage Blows Past Bunk When Feeding	1. Deflector too high.	1. Lower deflector. 2. Add optional 18" deflector belting #810819.



## Section 6: 2660/2665 Balebuster Options

### 6.1 Grain tank Operation (Option)



**WARNING: DO NOT** climb into hopper, you could become trapped or injured by rotating augers. Before operating the “Grain tank” make sure all shields are in place.

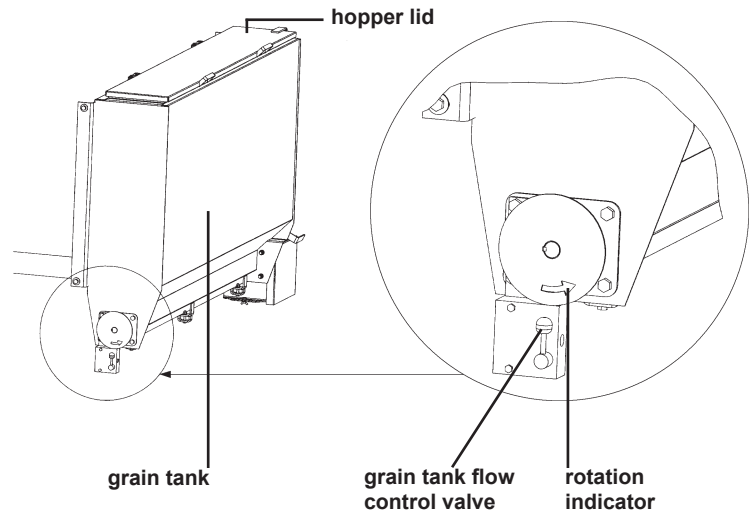
The grain tank is used for top-dressing feed supplements or can be use independently for supplement feeding.

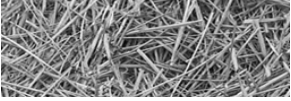
#### Hookup and Operation

Attach the hydraulic hoses to the tractor. Before filling the hopper with supplement, operate the augers to ensure that they rotate in the proper direction. There is an indicator arrow located on auger shaft at the front of the machine to show proper rotation and to serve as a visual indicator, that the hopper is in operation.

Follow the calibration procedure in this section, before feeding any supplement to ensure a proper feed ration.

The hopper should be filled using an auger. The hopper can also be filled manually, but from an elevated platform or other suitable structure.



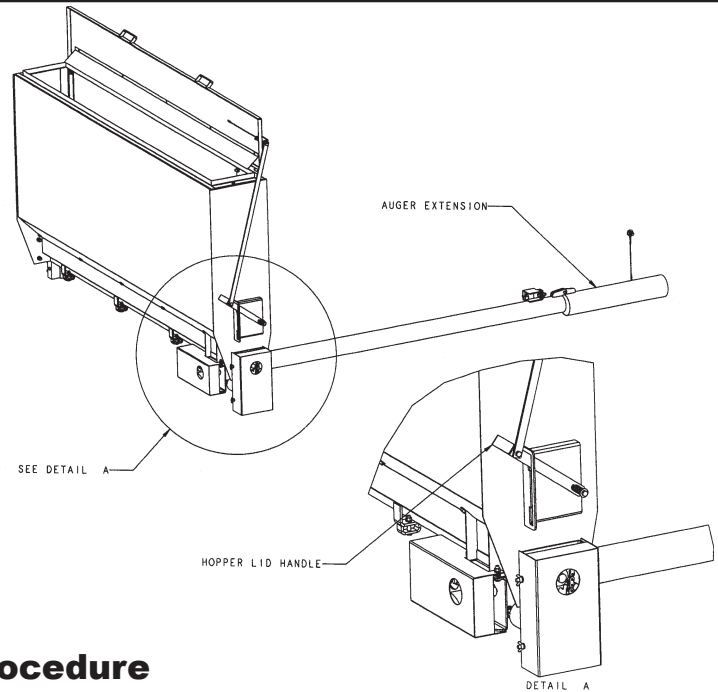


**WARNING: DO NOT** attempt to fill hopper by climbing on the machine.

The hopper lid can be opened and closed easily from the ground, by moving the hopper lid handle up for an open lid or down for a closed lid.

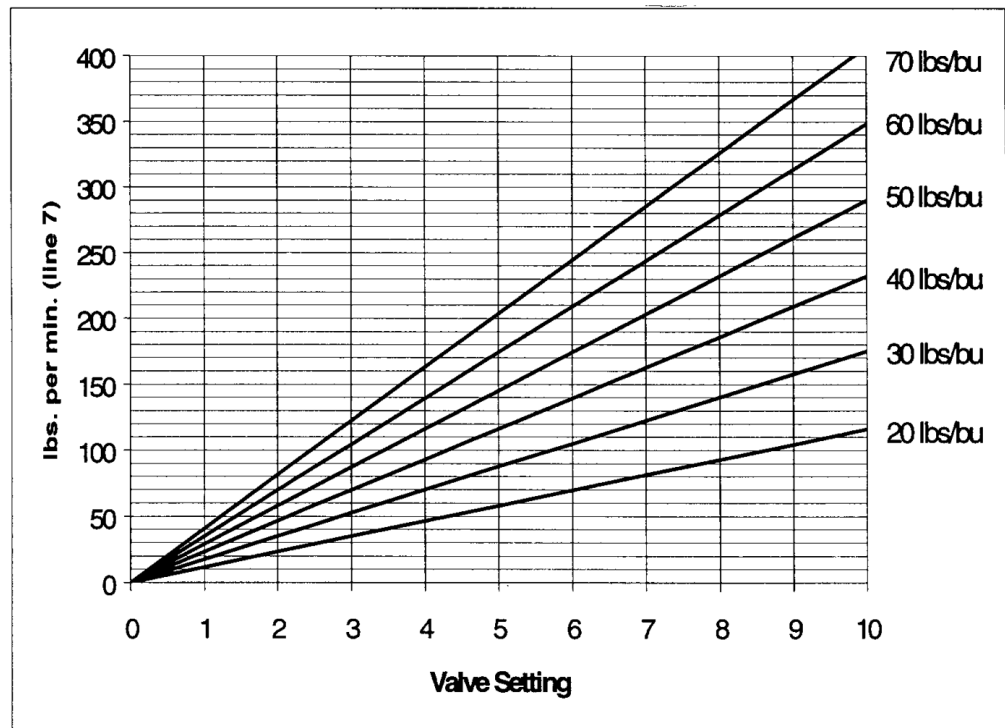
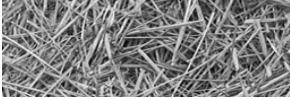
The auger extension tube lowers and raises in and out of operating position automatically when the rack is folded and unfolded.

The supplement may become lodged or compacted if left in hopper for extended periods of time. This may cause damage to the augers. Clean out the hopper and auger tubes before machine is put into storage. A removable clean-out plate is provided under the auger junction.



## 6.2 Grain tank (Option) Calibration Procedure

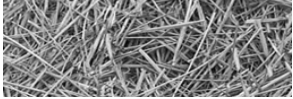
- Step 1.** Acquire the following information needed to fill out the calibration worksheet.
- A. The amount of hay (lbs.) that you feed per animal at each feeding time.
  - B. The amount of feed supplement (lbs.) that you feed per animal at each feeding time.
  - C. The average weight (lbs.) of the bales that are to be supplemented.
  - D. The average time (min.) required to process a bale that is to be supplemented.
  - E. The density (lbs. per bushel) of the feed supplement.
- Step 2.** Input the above information into the calibration worksheet (page 40) and calculate the “Required Hopper Feed Rate” to obtain the desired supplement to feed ratio.
- Step 3.** With the bale processor properly attached to the tractor operate the hopper making sure that both augers operate properly. While feeding and calibrating, the auger must rotate in the direction indicated by the arrow on the indicator wheel located at the front of the hopper.
- Step 4.** Using line 7 from worksheet set the flow valve at the baseline setting using the chart on next page.
- Step 5.** Fill the hopper with the feed supplement.
- Step 6.** With the tractor running at operating speed, operate the augers and collect the supplement, measuring the time required to fill a container. Adjust the flow valve up or down until the desired rate is obtained.



\* This chart is for a baseline setting only and should not be considered accurate because of variances in tractor hydraulic flows and pressures. The hopper must be recalibrated if the tractor is changed.

### Haybuster Grain Hopper Calibration Worksheet

		Example
<b>Line Feed Ratio Per Animal</b>		
1	Hay _____ (lbs.)	40 (lbs.)
2	Feed Supplement _____ (lbs.)	5 (lbs.)
3	Line 1 divided by Line 2 _____	8
<b>Bale Processing Rate</b>		
4	Bale Weight _____ (lbs.)	1200 (lbs.)
5	Process Time _____ (min.)	4 (min.)
6	Line 4 divided by Line 5 _____ (lbs./min.)	300 (lbs./min.)
<b>Required Hopper Feed Rate</b>		
7	Line 6 divided by Line 3 _____ (lbs./min.)	37.5 (lbs./min.)
8	Feed Supplement Density _____ (lbs./bushel)	50 (lbs./bushel)
9	Line 7 divided by Line 8 _____ (bushels/min)	0.75 (bushels/min)
10	Line 9 multiplied by 9.3 _____ (gal./min)	6.96 (gal./min)
11	60 divided by Line 10 _____ (sec/gal)	8.6 (sec/gal)



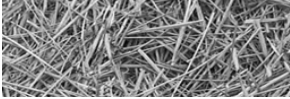
- Line 1.** The amount of hay that is fed to each animal, in pounds, on a daily basis.  
**Example:** Each animal is fed 40 lbs. of hay each day.
- Line 2.** The amount of feed supplement that is fed to each animal, in pounds, on a daily basis.  
**Example:** Each animal is fed 5 lbs. of feed supplement each day.
- Line 3.** Feed Ratio Per Animal: This result gives the amount of hay fed to each animal, in pounds, per 1 pound of feed supplement.
- Line 4.** The average weight of the bales that are to be processed while being supplemented  
**Example:** The average weight of the bales is 1200 pounds.
- Line 5.** The average time it takes to process a bale that is to be processed while being supplemented.  
**Example:** The average time it takes to process a bale is 4 minutes.
- Line 6.** Bale Processing Rate: This result gives the amount of hay processed, in pounds, per minute.
- Line 7.** Required Hopper Feed Rate: This is the amount of grain the hopper must feed out to maintain the desired “Feed Ratio Per Animal”, in pounds of feed supplement per minute.
- Line 8.** The density of the feed supplement, in pounds per bushel.  
**Example:** The density of the feed supplement is 50 pounds per bushel.
- Line 9.** Converts Line 7 (Required Hopper Feed Rate) into a feed rate of bushels of supplement per min.
- Line 10.** Converts Line 9 into a feed rate of gallons of supplement per min.
- Line 11.** Converts Line 10 into the time required to fill, a 1 gallon container, in seconds per gallon.

### 6.3 Hydraulic Deflector (Option)

The hydraulic deflector moves the rack and deflector from transport position to working position. Connecting the hydraulic hoses to the tractor gives the operator control of the deflector from inside the tractor.



**Rack and deflector in transport position**

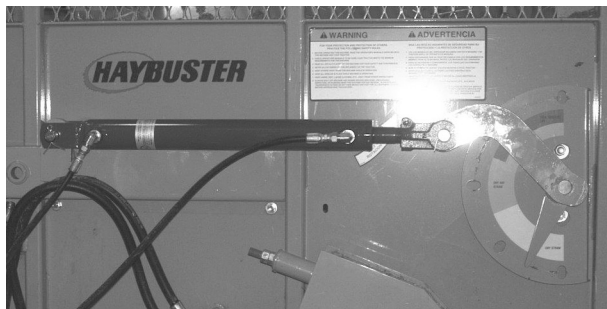


Rack and deflector in working position



## 6.4 Hydraulic Slug Bar (Option)

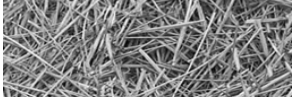
The hydraulic slug bar raises and lowers the slug bars as needed for your processing condition. Connecting the hydraulic hoses to the tractor gives the operator control of the slug bars from inside the tractor.



Hydraulic slug bar cylinder shown in the lowest position



Hydraulic slug bar cylinder shown in the highest raised position



## 6.5 Containment Flap (Option)

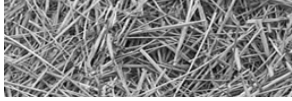


containment flap

## 6.6 Containment Extensions (Option)



containment extensions



## Section 7: Maintenance

### 7.1 Welding Procedure

#### Balebuster Welding Procedures For Machines With The Weigh Scale Option

Precautions are required for welding on machines with electronic components. Electronic components including but not limited to: electronic scales

Proper welding procedures are necessary in order to avoid damage to the components, their sensors, and associated components.

When possible, remove the parts to be welded from the machine.

If not possible to remove the parts, follow the following procedure:



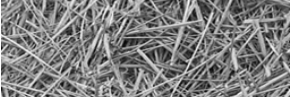
**NOTE:** Do not ground the welder to electrical components listed above, sensors, or wiring. Improper grounding can also damage bearings or hydraulic components. Clamp the ground cable from the welder to the part that will be welded. Place the clamp as close as possible to the weld. This will help reduce the possibility of damage.

1. Unhitch the Balebuster from the tractor.
2. Disconnect the connectors from the electronic scale. Move the connectors to a position that will not allow the connectors to accidentally move back and make contact with any of the pins.
3. Connect the welding ground cable directly to the part that will be welded. Place the ground cable as close as possible to the weld in order to reduce the possibility of welding current damage to bearings, hydraulic components, and electrical components.



**NOTE:** If the electrical/electronic components are used as a ground for the welder, or electrical/electronic components are located between the welder ground and the weld, current flow from the welder could damage the components.

4. Protect the wiring harnesses and hydraulic lines from welding debris and spatter.
5. Use standard techniques to weld the materials.



## Appendix A: WARRANTY

Duratech Industries International Inc. warrants to the original purchaser for one year from purchase date that this product will be free from defects in material and workmanship when used as intended and under normal maintenance and operating conditions. This warranty is limited to the replacement of any defective part or parts returned to our factory in Jamestown, N.D., within thirty (30) days of failure.

This warranty shall become void if in DuraTech Industries International, Inc.'s., judgment the machine has been subject to misuse, negligence, alterations, damaged by accident or lack of required normal maintenance, or if the product has been used for a purpose for which it was not designed.

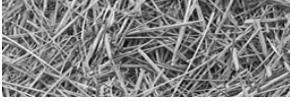
All claims for warranty must be made through the dealer which originally sold the product and all warranty adjustments must be made through same.

This warranty does not apply to tires or bearings or any other trade accessories not manufactured by DuraTech Industries International Inc.'s.. Buyer must rely solely on the existing warranty, if any, of these respective manufactures.

DuraTech Industries International Inc., shall **not** be held liable for damages of any kind, direct, contingent, or consequential to property under this warranty. DuraTech Industries International Inc., cannot be held liable for any damages resulting from causes beyond its control. DuraTech Industries International Inc., shall **not** be held liable under this warranty for loss of crops, or rental costs or any expense or loss for labor or supplies.

DuraTech Industries International Inc., reserves the right to make changes in material and/or designs of this product at any time without notice.

All other warranties made with respect to this product, either expressed or implied, are hereby disclaimed by DuraTech Industries International Inc.



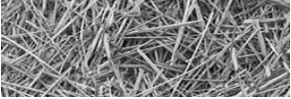
# Appendix B: 2660/2665 Specifications

## General specifications

Tractor H.P. Required.....	Min. 65 H.P.
Capacity.....	6 Ft. Long x 6-1/2 Ft. Dia., 2200 Lbs 1.83 m Long x 1.98 m Dia., 997 kg
Rotor Length .....	78” (1.98 m)
Rotor Diameter .....	25” (43.5 cm)
Rotor Bearings - Ball .....	2” (5.08 cm)
Number Of Flails- Heat Treated.....	30
Wheel - Taper Roller Bearings - Tire Size .....	14L x 16.1-8ply
Working Position 1 Bale Height..... 10’ 10” (3.30 m)	
Length .....	14’ 11” (4.55 m)
Width .....	11’ 0” (3.35 m)
Working Position 2 Bales Height..... 10’ 10” (3.30 m)	
Length .....	19’ 7” (6.22 m)
Width .....	11’ 0” (3.35 m)
Transport Position:	
Length .....	14’ 11” (4.55m)
Width .....	8’ 4” (2.54 m)
Height .....	11’ 0” (3.35 m)
Weight (2660/2665) .....	5,025 Lbs./5,150 Lbs. (2279 kg /2336 kg)
P.T.O .....	1000 RPM
Dual Hydraulics (single hydraulic system optional).....	1500 psi (103 bar)
Cylinder 4-1/2” x 24” Double Acting	

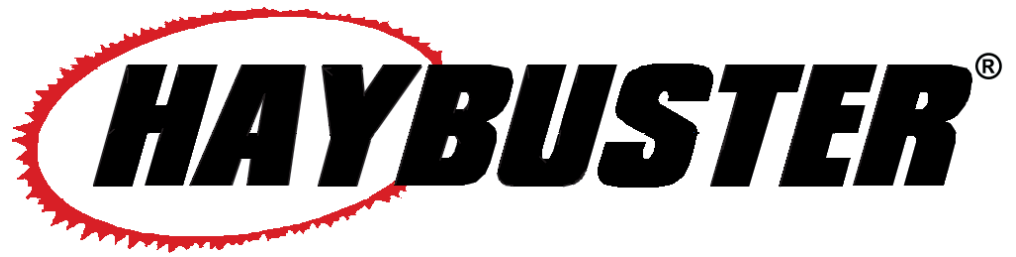
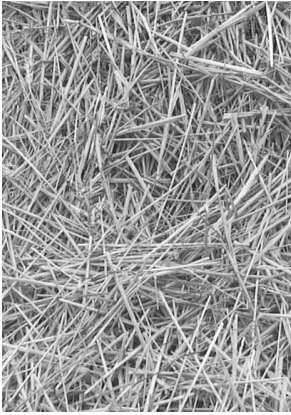
## Options

- Hydraulic Deflector
- Containment Extension
- Containment Flap
- Wide Deflector Belt
- Fender (Use with highway tires only.)
- Grain Tank
- Scale



## Appendix C: Grain tank (Option) Specifications

Option Wt. ....	650 lbs (approx)
Hopper Capacity.....	21 bu
Max Weight Capacity.....	1300 lbs
Max supplement Delivery rate.....	3.5 bu/min
Hyd. Press. Req.....	1500 psi
Hyd. Flow Req. ....	8 gpm



**2660<sup>TM</sup> / 2665<sup>TM</sup>**

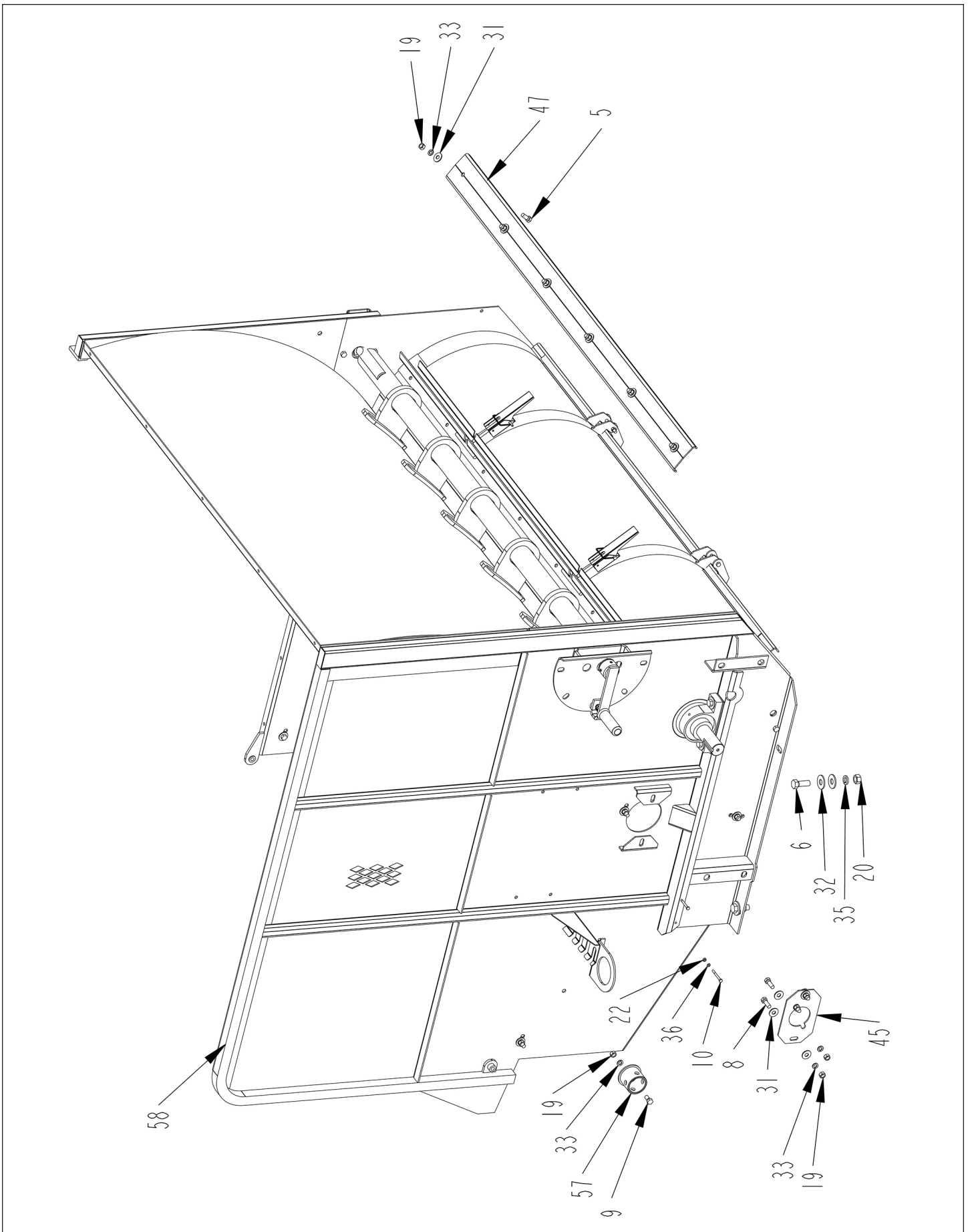
**BALEBUSTER**

**2660 - Serial Number 2615000160 & Up**

**2665 - Serial Number 2615000165 & Up**

**Part 2:  
Parts Reference**

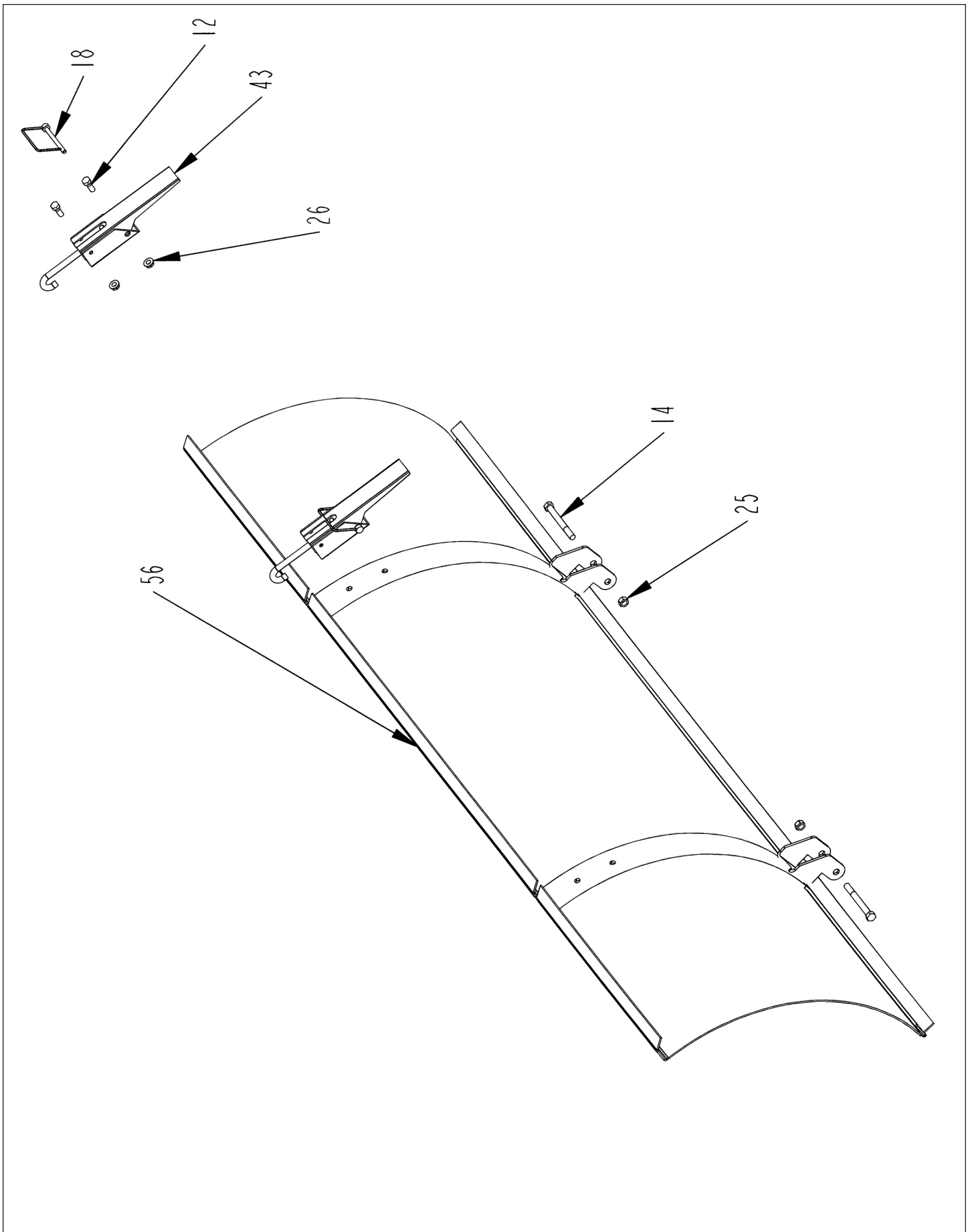
2660 SHREDDER ASSEMBLY - FRONT



**2660 SHREDDER ASSEMBLY - FRONT**

ITEM	PART	QTY.	PART DESCRIPTION
1	2000510	2	BRG\PB\2\2BOLT
2	8101462	2	SHM\16GA\BRG\RTR
3	8101631	2	SHM\10GA\BRG\RTR
4	2000813	1	CLLR\SHFT\1-1/2\SET
5	4800018	10	BOLT\HEX\1/2X1-1/4
6	4800033	4	BOLT\HEX\3/4X2
7	4800079	4	BOLT\HEX\5/8X2-1/2
8	4800082	14	BOLT\HEX\1/2X1-1/2
9	4800085	1	BOLT\HEX\1/2X1
10	4800101	2	BOLT\HEX\1/4X2-1/2
11	4800143	2	SCR\SET\ALN\3/8X3/8\NC
12	4800147	4	BOLT\HEX\5/16X7/8
13	4800178	4	BOLT\HEX\1/2X1-3/4
14	4800197	2	BOLT\HEX\3/8X3-1/2
15	4800456	1	PIN\RLLD\3/16X1-1/8
16	4800483	5	BOLT\CRG\5/8X2\NC
17	4800598	30	BOLT\HEX\5/8X4\NF\GR8
18	4800911	2	PIN\LYNCH\1/4X2-1/2\
19	4900001	27	NUT\HEX\1/2\NC
20	4900004	4	NUT\HEX\3/4\NC
21	4900005	4	NUT\HEX\5/8\NC
22	4900009	2	NUT\HEX\1/4\NC
23	4900012	5	NUT\TPLCK\5/8\NC
24	4900014	2	NUT\TPLCK\1/2\NC
25	4900023	3	NUT\TPLCK\3/8\NC
26	4900108	4	NUT\FLG\SERR\5/16\NC
27	4900143	30	NUT\TPLCK\5/8\GR8\NF
28	5000001	2	WASH\FLAT\3/8
29	5000002	8	WASH\FLAT\5/8
30	5000003	4	WASH\LOCK\5/8
31	5000004	30	WASH\FLAT\1/2
32	5000005	8	WASH\FLAT\3/4
33	5000006	27	WASH\LOCK\1/2
34	5000008	1	WASH\MACH\1-1/2\DX10GA\NR
35	5000012	4	WASH\LOCK\3/4
36	5000024	2	WASH\LOCK\1/4
37	5200012	30	FLAIL\BB\8
38	6100002	1	SPRING\COMPL.072W\11/16OD\2-1/8\LONG
39	6100031	1	SPRING\COMPL.072W\25/32OD
40	6200021	1	KEY\SQ\3/8X1-1/2\HARDEND
41	7500223	30	BUSH\FLAIL\1-1/4X.687x2-1/8L
42	7500736	1	GRIP\HAND\1X4-1/2\FLG
43	7501045	2	LATCH\ADJ\OTC\4" GRIP
44	7501050	2	PLATE\SICKLE
45	8100036	1	MNT\MTR\HYD
46	8100763	5	BAR\SLUG\ADJ
47	8100793	opt.	CHNNL\STRIPPER\SHREDDER
47a	8101511	opt.	CHNNL\STRIPPER\69"OPTION
48	8100877	1	LATCH\SHLD\BRG\REAR\RTR
49	8100879	1	MNT\SHLD\REAR\BRG\RTR
50	8101038	1	BRKT\INDEX\SLUGBAR
51	8101039	1	BRKT\BRG\SLUGBAR
52	8101050	1	ROD\HANDLE\INDEX\SLUGBAR
53	8101051	1	BRKT\MNT\HANDLE\SLUGBAR
54	8101094	1	SHAFT\SLUGBAR\2650
55	8101313	1	PAN\DISH\ADJ
56	8101512	1	BRKT\DOOR\2650
57	8101748	1	BRKT\STRG\JACK
58	8101857	1	FRM\SHRDR\RH\2660
59	8101890	1	RTR\FLAIL\2"SHFT\HVY
60	8101894	1	BRKT\BRG\2"REAR\RTR
61	8101951	1	SHLD\2"BRG\REAR\RTR

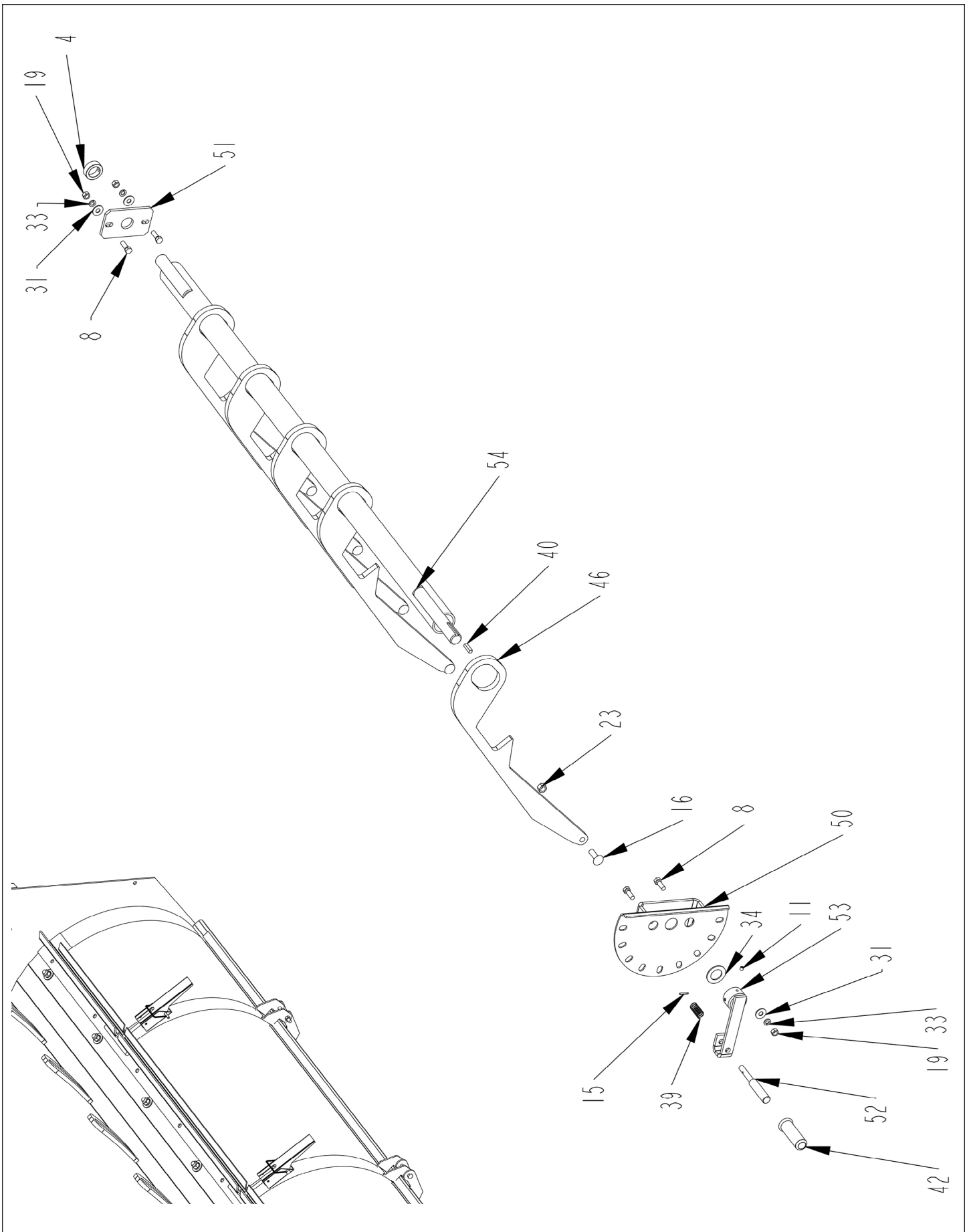
2660 SHREDDER ASSEMBLY - DOOR



**2660 SHREDDER ASSEMBLY - DOOR**

ITEM	PART	QTY.	PART DESCRIPTION
1	2000510	2	BRG\PB\2\2BOLT
2	8101462	2	SHM\16GA\BRG\RTR
3	8101631	2	SHM\10GA\BRG\RTR
4	2000813	1	CLLR\SHFT\1-1/2\SET
5	4800018	10	BOLT\HEX\1/2X1-1/4
6	4800033	4	BOLT\HEX\3/4X2
7	4800079	4	BOLT\HEX\5/8X2-1/2
8	4800082	14	BOLT\HEX\1/2X1-1/2
9	4800085	1	BOLT\HEX\1/2X1
10	4800101	2	BOLT\HEX\1/4X2-1/2
11	4800143	2	SCR\SET\ALN\3/8X3/8\NC
12	4800147	4	BOLT\HEX\5/16X7/8
13	4800178	4	BOLT\HEX\1/2X1-3/4
14	4800197	2	BOLT\HEX\3/8X3-1/2
15	4800456	1	PIN\RLLD\3/16X1-1/8
16	4800483	5	BOLT\CRG\5/8X2\NC
17	4800598	30	BOLT\HEX\5/8X4\NF\GR8
18	4800911	2	PIN\LYNCH\1/4X2-1/2\
19	4900001	27	NUT\HEX\1/2\NC
20	4900004	4	NUT\HEX\3/4\NC
21	4900005	4	NUT\HEX\5/8\NC
22	4900009	2	NUT\HEX\1/4\NC
23	4900012	5	NUT\TPLCK\5/8\NC
24	4900014	2	NUT\TPLCK\1/2\NC
25	4900023	3	NUT\TPLCK\3/8\NC
26	4900108	4	NUT\FLG\SERR\5/16\NC
27	4900143	30	NUT\TPLCK\5/8\GR8\NF
28	5000001	2	WASH\FLAT\3/8
29	5000002	8	WASH\FLAT\5/8
30	5000003	4	WASH\LOCK\5/8
31	5000004	30	WASH\FLAT\1/2
32	5000005	8	WASH\FLAT\3/4
33	5000006	27	WASH\LOCK\1/2
34	5000008	1	WASH\MACH\1-1/2\DX10GA\NR
35	5000012	4	WASH\LOCK\3/4
36	5000024	2	WASH\LOCK\1/4
37	5200012	30	FLAIL\BB\8
38	6100002	1	SPRING\COMPL.072W\11/16OD\2-1/8\LONG
39	6100031	1	SPRING\COMPL.072W\25/32OD
40	6200021	1	KEY\SQ\3/8X1-1/2\HARDEND
41	7500223	30	BUSH\FLAIL\1-1/4X.687x2-1/8L
42	7500736	1	GRIP\HAND\1X4-1/2\FLG
43	7501045	2	LATCH\ADJ\OTC\4" GRIP
44	7501050	2	PLATE\SICKLE
45	8100036	1	MNT\MTR\HYD
46	8100763	5	BAR\SLUG\ADJ
47	8100793	opt.	CHNNL\STRIPPER\SHREDDER
47a	8101511	opt.	CHNNL\STRIPPER\69"OPTION
48	8100877	1	LATCH\SHLD\BRG\REAR\RTR
49	8100879	1	MNT\SHLD\REAR\BRG\RTR
50	8101038	1	BRKT\INDEX\SLUGBAR
51	8101039	1	BRKT\BRG\SLUGBAR
52	8101050	1	ROD\HANDLE\INDEX\SLUGBAR
53	8101051	1	BRKT\MNT\HANDLE\SLUGBAR
54	8101094	1	SHAFT\SLUGBAR\2650
55	8101313	1	PAN\DISH\ADJ
56	8101512	1	BRKT\DOOR\2650
57	8101748	1	BRKT\STRG\JACK
58	8101857	1	FRM\SHRDR\RH\2660
59	8101890	1	RTR\FLAIL\2"SHFT\HVY
60	8101894	1	BRKT\BRG\2"REAR\RTR
61	8101951	1	SHLD\2"BRG\REAR\RTR

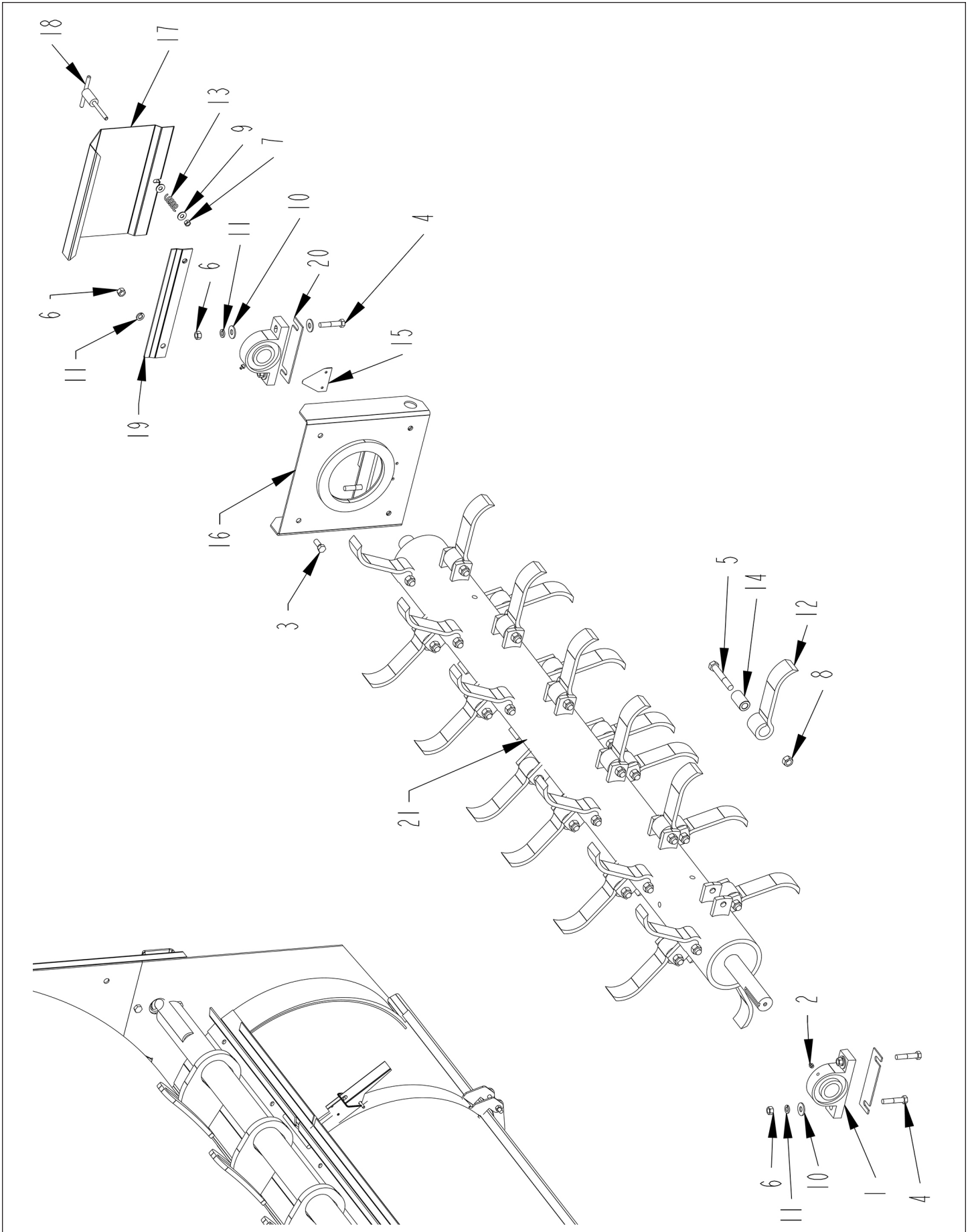
2660 SHREDDER ASSEMBLY - SLUGBAR



**2660 SHREDDER ASSEMBLY - SLUGBAR**

ITEM	PART	QTY.	PART DESCRIPTION
1	2000510	2	BRG\PB\2\2BOLT
2	8101462	2	SHM\16GA\BRG\RTR
3	8101631	2	SHM\10GA\BRG\RTR
4	2000813	1	CLLR\SHFT\1-1/2\SET
5	4800018	10	BOLT\HEX\1/2X1-1/4
6	4800033	4	BOLT\HEX\3/4X2
7	4800079	4	BOLT\HEX\5/8X2-1/2
8	4800082	14	BOLT\HEX\1/2X1-1/2
9	4800085	1	BOLT\HEX\1/2X1
10	4800101	2	BOLT\HEX\1/4X2-1/2
11	4800143	2	SCR\SET\ALN\3/8X3/8\NC
12	4800147	4	BOLT\HEX\5/16X7/8
13	4800178	4	BOLT\HEX\1/2X1-3/4
14	4800197	2	BOLT\HEX\3/8X3-1/2
15	4800456	1	PIN\RLLD\3/16X1-1/8
16	4800483	5	BOLT\CRG\5/8X2\NC
17	4800598	30	BOLT\HEX\5/8X4\NF\GR8
18	4800911	2	PIN\LYNCH\1/4X2-1/2\
19	4900001	27	NUT\HEX\1/2\NC
20	4900004	4	NUT\HEX\3/4\NC
21	4900005	4	NUT\HEX\5/8\NC
22	4900009	2	NUT\HEX\1/4\NC
23	4900012	5	NUT\TPLCK\5/8\NC
24	4900014	2	NUT\TPLCK\1/2\NC
25	4900023	3	NUT\TPLCK\3/8\NC
26	4900108	4	NUT\FLG\SERR\5/16\NC
27	4900143	30	NUT\TPLCK\5/8\GR8\NF
28	5000001	2	WASH\FLAT\3/8
29	5000002	8	WASH\FLAT\5/8
30	5000003	4	WASH\LOCK\5/8
31	5000004	30	WASH\FLAT\1/2
32	5000005	8	WASH\FLAT\3/4
33	5000006	27	WASH\LOCK\1/2
34	5000008	1	WASH\MACH\1-1/2\DX10GA\NR
35	5000012	4	WASH\LOCK\3/4
36	5000024	2	WASH\LOCK\1/4
37	5200012	30	FLAIL\BB\8
38	6100002	1	SPRING\COMPL.072W\11/16OD\2-1/8\LONG
39	6100031	1	SPRING\COMPL.072W\25/32OD
40	6200021	1	KEY\SQ\3/8X1-1/2\HARDEND
41	7500223	30	BUSH\FLAIL\1-1/4X.687x2-1/8L
42	7500736	1	GRIP\HAND\1X4-1/2\FLG
43	7501045	2	LATCH\ADJ\OTC\4" GRIP
44	7501050	2	PLATE\SICKLE
45	8100036	1	MNT\MTR\HYD
46	8100763	5	BAR\SLUG\ADJ
47	8100793	opt.	CHNNL\STRIPPER\SHREDDER
47a	8101511	opt.	CHNNL\STRIPPER\69"OPTION
48	8100877	1	LATCH\SHLD\BRG\REAR\RTR
49	8100879	1	MNT\SHLD\REAR\BRG\RTR
50	8101038	1	BRKT\INDEX\SLUGBAR
51	8101039	1	BRKT\BRG\SLUGBAR
52	8101050	1	ROD\HANDLE\INDEX\SLUGBAR
53	8101051	1	BRKT\MNT\HANDLE\SLUGBAR
54	8101094	1	SHAFT\SLUGBAR\2650
55	8101313	1	PAN\DISH\ADJ
56	8101512	1	BRKT\DOOR\2650
57	8101748	1	BRKT\STRG\JACK
58	8101857	1	FRM\SHRDR\RH\2660
59	8101890	1	RTR\FLAIL\2"SHFT\HVY
60	8101894	1	BRKT\BRG\2"REAR\RTR
61	8101951	1	SHLD\2"BRG\REAR\RTR

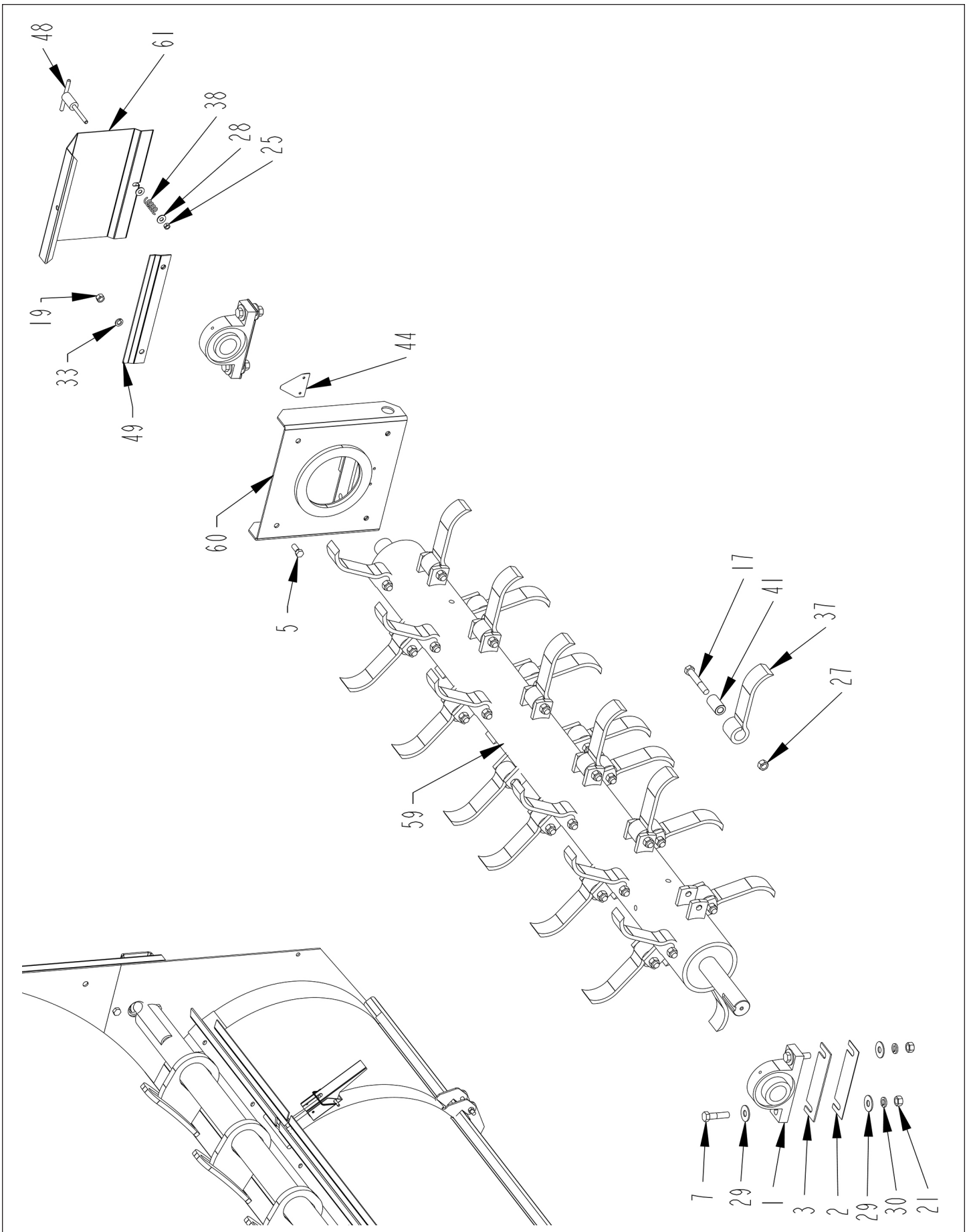
2660 SHREDDER ASSEMBLY - ROTOR (S.N. 0001 THRU 0005)



**2660 SHREDDER ASSEMBLY - ROTOR (S.N. 0001 THRU 0005)**

<b>ITEM</b>	<b>PART</b>	<b>QTY.</b>	<b>PART DESCRIPTION</b>
1	2000514	2	BRG\PB\1-3/4\2BOLT\MALLEABLE
2	3800043	2	FTG\LUB\1/8MPXZRK\SHORT
3	4800018	4	BOLT\HEX\1/2X1-1/4
4	4800070	4	BOLT\HEX\1/2X2-1/2
5	4800598	30	BOLT\HEX\5/8X4\NF\GR8
6	4900001	8	NUT\HEX\1/2\NC
7	4900023	1	NUT\TPLCK\3/8\NC
8	4900179	30	NUT\TPLCK\RTR\5/8\NF\GR9
9	5000001	2	WASH\FLAT\3/8
10	5000004	8	WASH\FLAT\1/2
11	5000006	4	WASH\LOCK\1/2
12	5200012	30	FLAIL\BB\8
13	6100002	1	SPRING\COMP\.072W\11/16OD\2-1/8LONG
14	7500223	30	BUSH\FLAIL\1-1/4X.687x2-1/8L
15	7501050	2	PLATE\SICKLE
16	8100778	1	BRKT\BRG\REAR\RTR
17	8100876	1	SHLD\BRG\REAR\RTR
18	8100877	1	LATCH\SHLD\BRG\REAR\RTR
19	8100879	1	MNT\SHLD\REAR\BRG\RTR
20	8100890	2	SHM\10GA\BRG\RTR
21	8101341	1	RTR\FLAIL\78-3/8\2640

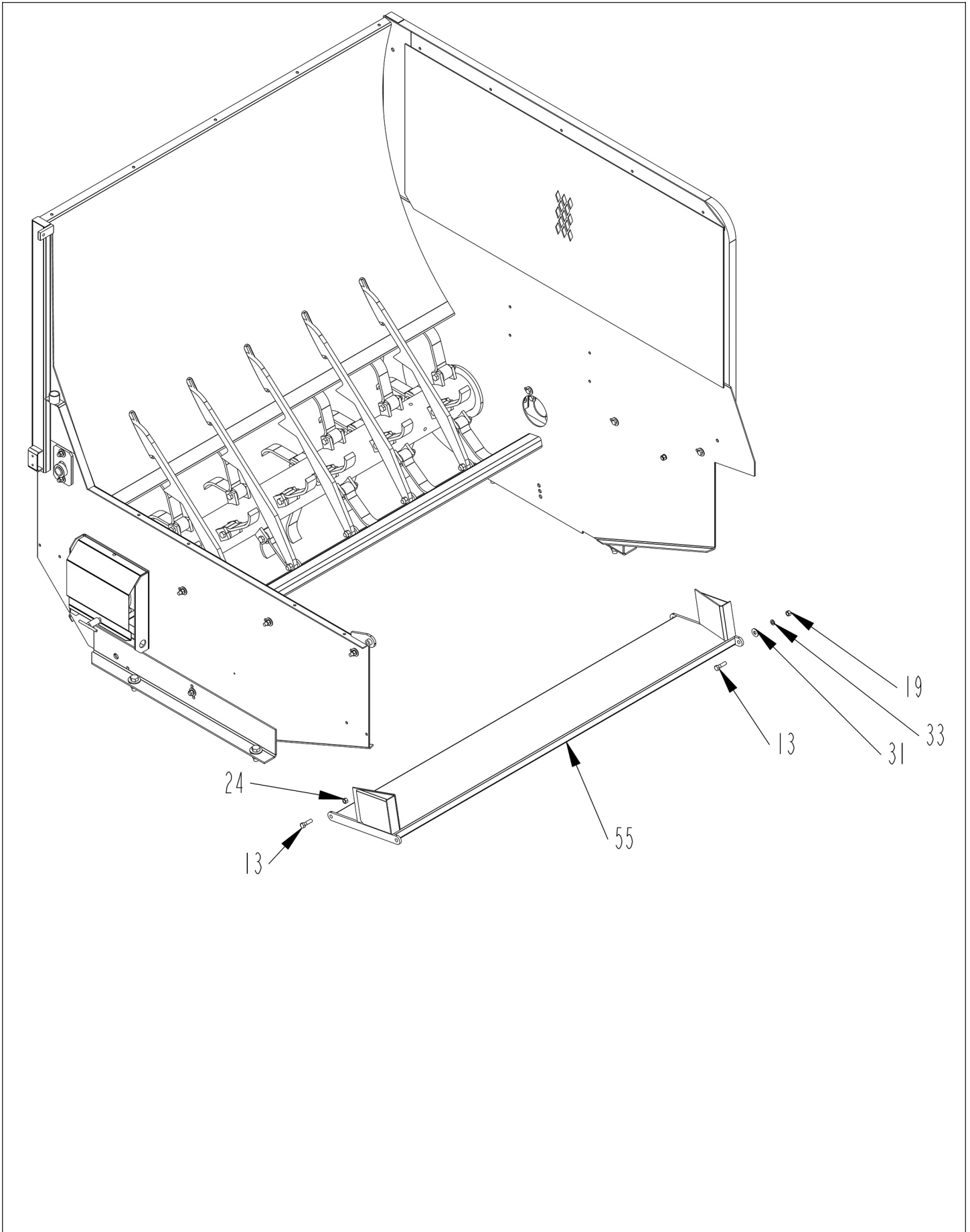
2660 SHREDDER ASSEMBLY - ROTOR (S.N. 0006 AND UP)



**2660 SHREDDER ASSEMBLY - ROTOR (S.N. 0006 AND UP)**

ITEM	PART	QTY.	PART DESCRIPTION
1	2000510	2	BRG\PB\2\2BOLT
2	8101462	2	SHM\16GA\BRG\RTR
3	8101631	2	SHM\10GA\BRG\RTR
4	2000813	1	CLLR\SHFT\1-1/2\SET
5	4800018	10	BOLT\HEX\1/2X1-1/4
6	4800033	4	BOLT\HEX\3/4X2
7	4800079	4	BOLT\HEX\5/8X2-1/2
8	4800082	14	BOLT\HEX\1/2X1-1/2
9	4800085	1	BOLT\HEX\1/2X1
10	4800101	2	BOLT\HEX\1/4X2-1/2
11	4800143	2	SCR\SET\ALN\3/8X3/8\NC
12	4800147	4	BOLT\HEX\5/16X7/8
13	4800178	4	BOLT\HEX\1/2X1-3/4
14	4800197	2	BOLT\HEX\3/8X3-1/2
15	4800456	1	PIN\RLLD\3/16X1-1/8
16	4800483	5	BOLT\CRG\5/8X2\NC
17	4800598	30	BOLT\HEX\5/8X4\NF\GR8
18	4800911	2	PIN\LYNCH\1/4X2-1/2\
19	4900001	27	NUT\HEX\1/2\NC
20	4900004	4	NUT\HEX\3/4\NC
21	4900005	4	NUT\HEX\5/8\NC
22	4900009	2	NUT\HEX\1/4\NC
23	4900012	5	NUT\TPLCK\5/8\NC
24	4900014	2	NUT\TPLCK\1/2\NC
25	4900023	3	NUT\TPLCK\3/8\NC
26	4900108	4	NUT\FLG\SERR\5/16\NC
27	4900179	30	NUT\TPLCK\5/8\NF\GR9
28	5000001	2	WASH\FLAT\3/8
29	5000002	8	WASH\FLAT\5/8
30	5000003	4	WASH\LOCK\5/8
31	5000004	30	WASH\FLAT\1/2
32	5000005	8	WASH\FLAT\3/4
33	5000006	27	WASH\LOCK\1/2
34	5000008	1	WASH\MACH\1-1/2\ID\10GA\NR
35	5000012	4	WASH\LOCK\3/4
36	5000024	2	WASH\LOCK\1/4
37	5200012	30	FLAIL\BB\8
38	6100002	1	SPRING\COMPL\072W\11/16OD\2-1/8\LONG
39	6100031	1	SPRING\COMPL\072W\25/32OD
40	6200021	1	KEY\SQ\3/8X1-1/2\HARDEND
41	7500223	30	BUSH\FLAIL\1-1/4X\687x2-1/8L
42	7500736	1	GRIP\HAND\1X4-1/2\FLG
43	7501045	2	LATCH\ADJ\OTC\4" GRIP
44	7501050	2	PLATE\SICKLE
45	8100036	1	MNT\MTR\HYD
46	8100763	5	BAR\SLUG\ADJ
47	8100793	opt.	CHNNL\STRIPPER\SHREDDER
47a	8101511	opt.	CHNNL\STRIPPER\69"OPTION
48	8100877	1	LATCH\SHLD\BRG\REAR\RTR
49	8100879	1	MNT\SHLD\REAR\BRG\RTR
50	8101038	1	BRKT\INDEX\SLUGBAR
51	8101039	1	BRKT\BRG\SLUGBAR
52	8101050	1	ROD\HANDLE\INDEX\SLUGBAR
53	8101051	1	BRKT\MNT\HANDLE\SLUGBAR
54	8101094	1	SHAFT\SLUGBAR\2650
55	8101313	1	PAN\DISH\ADJ
56	8101512	1	BRKT\DOOR\2650
57	8101748	1	BRKT\STRG\JACK
58	8101857	1	FRM\SHRDR\RH\2660
59	8101890	1	RTR\FLAIL\2"SHFT\HVY
60	8101894	1	BRKT\BRG\2"REAR\RTR
61	8101951	1	SHLD\2"BRG\REAR\RTR

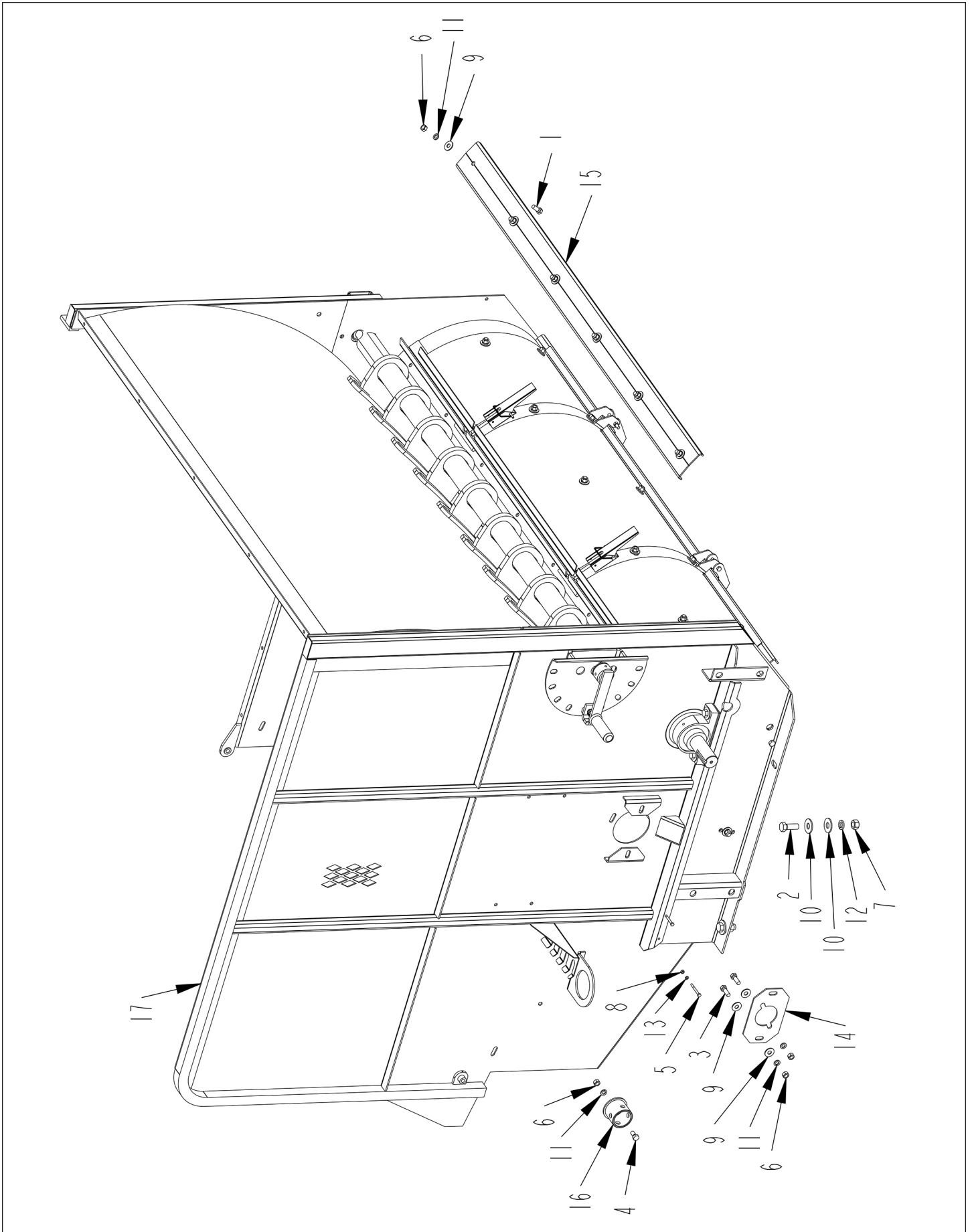
2660 SHREDDER ASSEMBLY - FLOOR PAN



**2660 SHREDDER ASSEMBLY - FLOOR PAN**

ITEM	PART	QTY.	PART DESCRIPTION
1	2000510	2	BRG\PB\2\2BOLT
2	8101462	2	SHM\16GA\BRG\RTR
3	8101631	2	SHM\10GA\BRG\RTR
4	2000813	1	CLLR\SHFT\1-1/2\SET
5	4800018	10	BOLT\HEX\1/2X1-1/4
6	4800033	4	BOLT\HEX\3/4X2
7	4800079	4	BOLT\HEX\5/8X2-1/2
8	4800082	14	BOLT\HEX\1/2X1-1/2
9	4800085	1	BOLT\HEX\1/2X1
10	4800101	2	BOLT\HEX\1/4X2-1/2
11	4800143	2	SCR\SET\ALN\3/8X3/8\NC
12	4800147	4	BOLT\HEX\5/16X7/8
13	4800178	4	BOLT\HEX\1/2X1-3/4
14	4800197	2	BOLT\HEX\3/8X3-1/2
15	4800456	1	PIN\RLLD\3/16X1-1/8
16	4800483	5	BOLT\CRG\5/8X2\NC
17	4800598	30	BOLT\HEX\5/8X4\NF\GR8
18	4800911	2	PIN\LYNCH\1/4X2-1/2\
19	4900001	27	NUT\HEX\1/2\NC
20	4900004	4	NUT\HEX\3/4\NC
21	4900005	4	NUT\HEX\5/8\NC
22	4900009	2	NUT\HEX\1/4\NC
23	4900012	5	NUT\TPLCK\5/8\NC
24	4900014	2	NUT\TPLCK\1/2\NC
25	4900023	3	NUT\TPLCK\3/8\NC
26	4900108	4	NUT\FLG\SERR\5/16\NC
27	4900143	30	NUT\TPLCK\5/8\GR8\NF
28	5000001	2	WASH\FLAT\3/8
29	5000002	8	WASH\FLAT\5/8
30	5000003	4	WASH\LOCK\5/8
31	5000004	30	WASH\FLAT\1/2
32	5000005	8	WASH\FLAT\3/4
33	5000006	27	WASH\LOCK\1/2
34	5000008	1	WASH\MACH\1-1/2\DX10GA\NR
35	5000012	4	WASH\LOCK\3/4
36	5000024	2	WASH\LOCK\1/4
37	5200012	30	FLAIL\BB\8
38	6100002	1	SPRING\COMPL.072W\11/16OD\2-1/8\LONG
39	6100031	1	SPRING\COMPL.072W\25/32OD
40	6200021	1	KEY\SQ\3/8X1-1/2\HARDEND
41	7500223	30	BUSH\FLAIL\1-1/4X.687x2-1/8L
42	7500736	1	GRIP\HAND\1X4-1/2\FLG
43	7501045	2	LATCH\ADJ\OTC\4" GRIP
44	7501050	2	PLATE\SICKLE
45	8100036	1	MNT\MTR\HYD
46	8100763	5	BAR\SLUG\ADJ
47	8100793	opt.	CHNNL\STRIPPER\SHREDDER
47a	8101511	opt.	CHNNL\STRIPPER\69"OPTION
48	8100877	1	LATCH\SHLD\BRG\REAR\RTR
49	8100879	1	MNT\SHLD\REAR\BRG\RTR
50	8101038	1	BRKT\INDEX\SLUGBAR
51	8101039	1	BRKT\BRG\SLUGBAR
52	8101050	1	ROD\HANDLE\INDEX\SLUGBAR
53	8101051	1	BRKT\MNT\HANDLE\SLUGBAR
54	8101094	1	SHAFT\SLUGBAR\2650
55	8101313	1	PAN\DISH\ADJ
56	8101512	1	BRKT\DOOR\2650
57	8101748	1	BRKT\STRG\JACK
58	8101857	1	FRM\SHRDR\RH\2660
59	8101890	1	RTR\FLAIL\2"SHFT\HVY
60	8101894	1	BRKT\BRG\2"REAR\RTR
61	8101951	1	SHLD\2"BRG\REAR\RTR

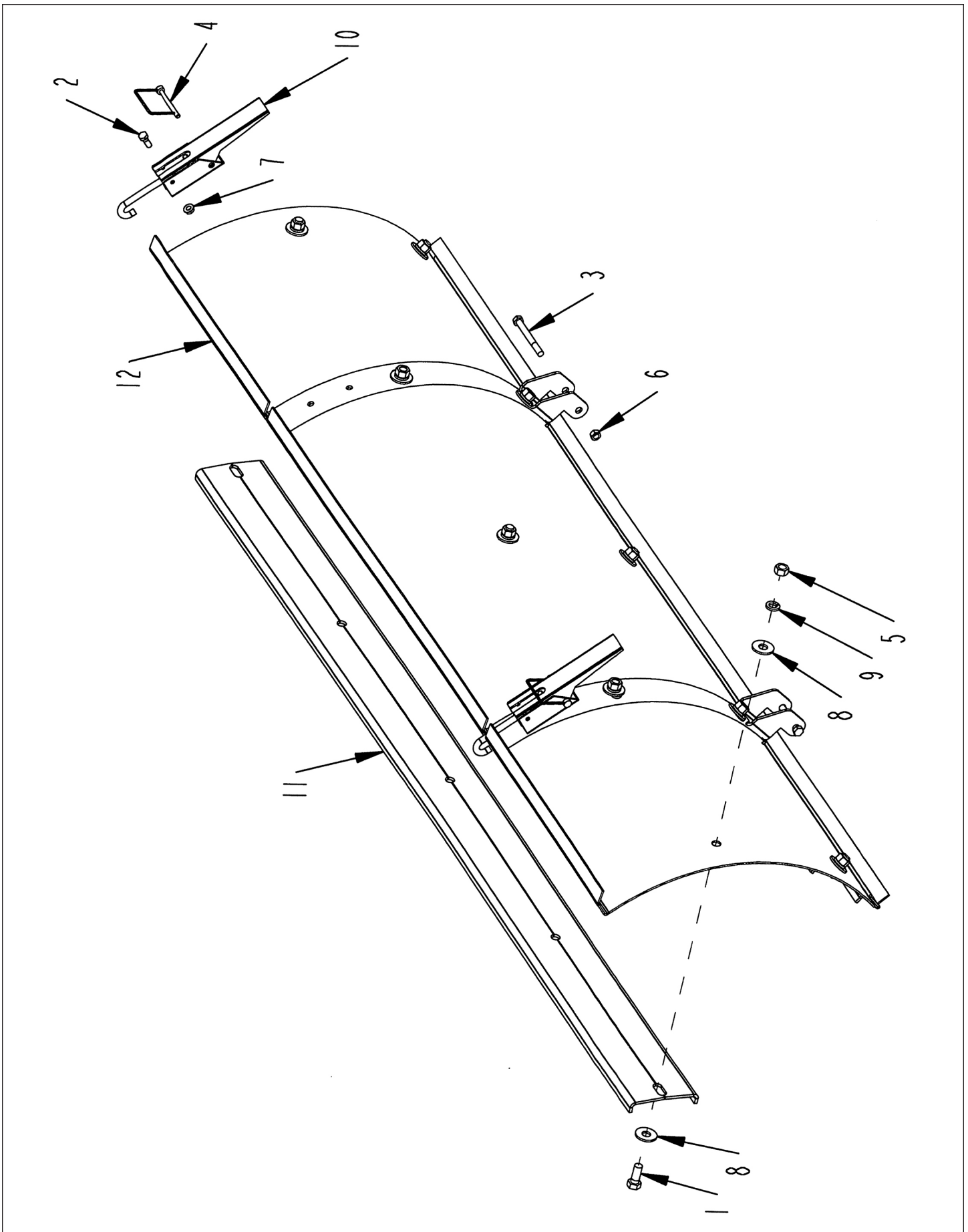
2665 SHREDDER ASSEMBLY - FRONT



**2665 SHREDDER ASSEMBLY - FRONT**

<b>ITEM</b>	<b>PART</b>	<b>QTY.</b>	<b>PART DESCRIPTION</b>
1	4800018	6	BOLT\HEX\1/2X1-1/4
2	4800033	4	BOLT\HEX\3/4X2
3	4800082	4	BOLT\HEX\1/2X1-1/2
4	4800085	1	BOLT\HEX\1/2X1
5	4800101	2	BOLT\HEX\1/4X2-1/2
6	4900001	9	NUT\HEX\1/2\NC
7	4900004	4	NUT\HEX\3/4\NC
8	4900009	2	NUT\HEX\1/4\NC
9	5000004	12	WASH\FLAT\1/2
10	5000005	8	WASH\FLAT\3/4
11	5000006	11	WASH\LOCK\1/2
12	5000012	4	WASH\LOCK\3/4
13	5000024	2	WASH\LOCK\1/4
14	8100036	1	MNT\MTR\HYD
15	8100793	1	CHNNL\STRIPPER\SHREDDER
16	8101748	1	BRKT\STRG\JACK
17	8101879	1	FRM\SHRDR\RH\2665

2665 SHREDDER ASSEMBLY - DOOR



**2665 SHREDDER ASSEMBLY - DOOR**

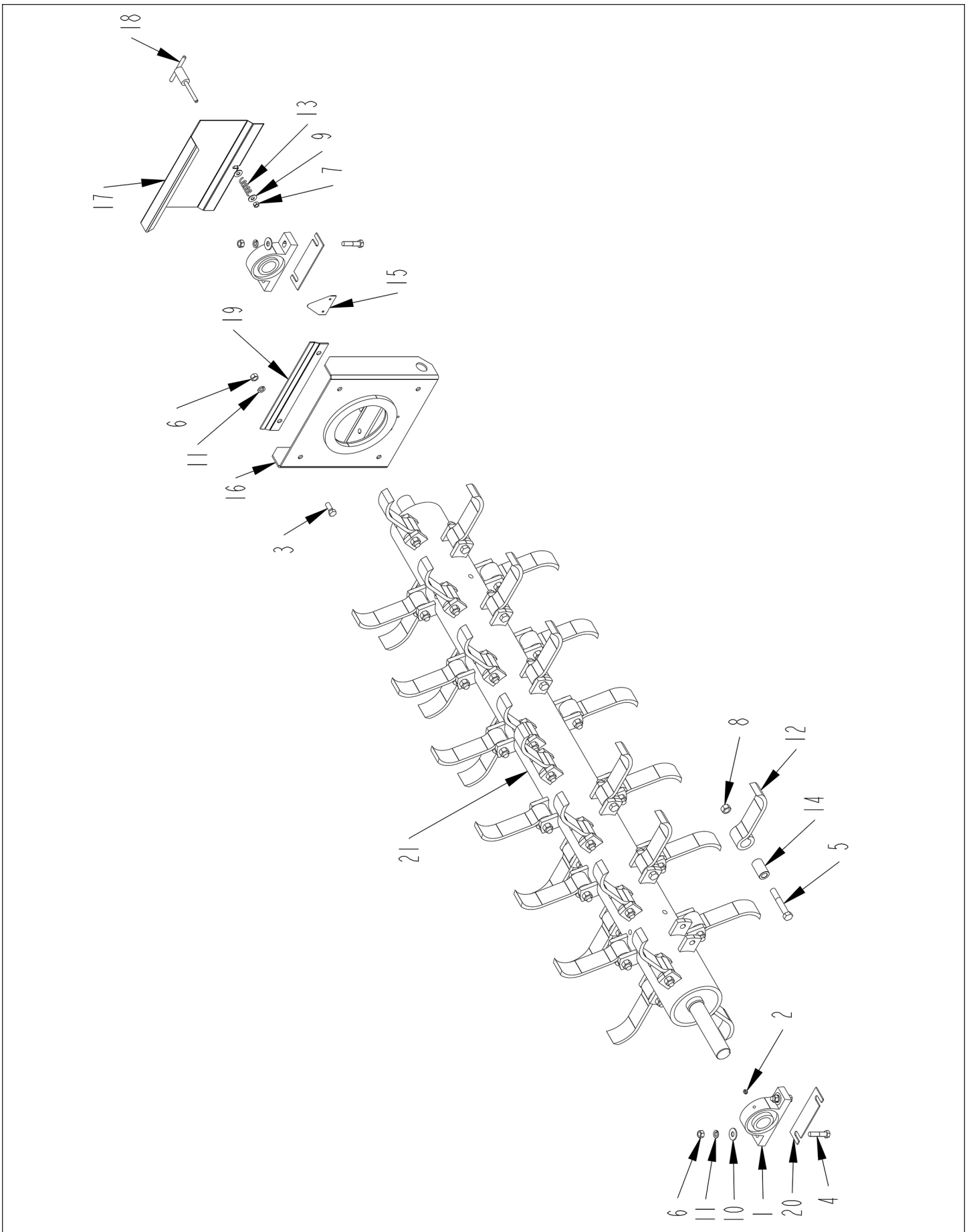
<b>ITEM</b>	<b>PART</b>	<b>QTY.</b>	<b>PART DESCRIPTION</b>
1	4800018	10	BOLT\HEX\1/2X1-1/4
2	4800147	4	BOLT\HEX\5/16X7/8
3	4800197	2	BOLT\HEX\3/8X3-1/2
4	4800911	2	PIN\LYNCH\1/4X2-1/2\
5	4900001	10	NUT\HEX\1/2\NC
6	4900023	2	NUT\TPLCK\3/8\NC
7	4900108	4	NUT\FLG\SERR\5/16\NC
8	5000004	20	WASH\FLAT\1/2
9	5000006	10	WASH\LOCK\1/2
10	7501045	2	LATCH\ADJ\OTC\4" GRIP
11	8101511	2	CHNNL\STRIPPER\69"\OPTION
12	8101787	1	DOOR\SHRDR\71-1/4W-MNT-HOLES



**2665 SHREDDER ASSEMBLY - SLUGBAR**

<b>ITEM</b>	<b>PART</b>	<b>QTY.</b>	<b>PART DESCRIPTION</b>
1	2000813	1	CLLR\SHFT\1-1/2\SET
2	4800082	4	BOLT\HEX\1/2X1-1/2
3	4800143	2	SCR\SET\ALN\3/8X3/8\NC
4	4800456	1	PIN\RLLD\3/16X1-1/8
5	4800483	9	BOLT\CRG\5/8X2\NC
6	4900001	4	NUT\HEX\1/2\NC
7	4900012	9	NUT\TPLCK\5/8\NC
8	5000004	4	WASH\FLAT\1/2
9	5000006	4	WASH\LOCK\1/2
10	5000008	1	WASH\MACH\1-1/2IDX10GA\NR
11	6100031	1	SPRING\COMP\.072W\25/32OD
12	6200021	1	KEY\SQ\3/8X1-1/2\HARDEND
13	7500736	1	GRIP\HAND\1X4-1/2\FLG
14	8100763	9	BAR\SLUG\ADJ
15	8101038	1	BRKT\INDEX\SLUGBAR
16	8101039	1	BRKT\BRG\SLUGBAR
17	8101050	1	ROD\HANDLE\INDEX\SLUGBAR
18	8101051	1	BRKT\MNT\HANDLE\SLUGBAR
19	8101094	1	SHAFT\SLUGBAR\2650

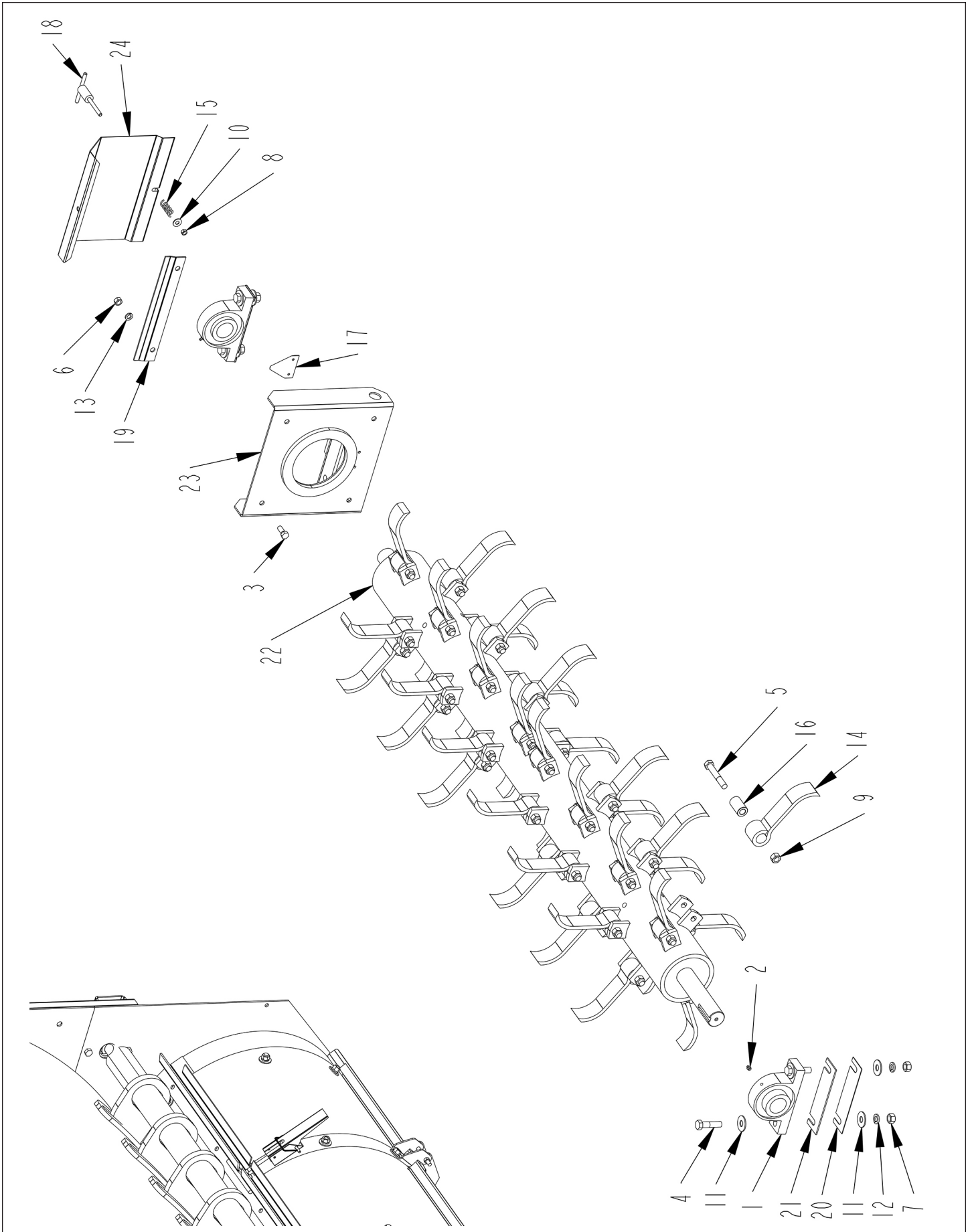
2665 SHREDDER ASSEMBLY - ROTOR (S.N. 0001 THRU 0005)



**2665 SHREDDER ASSEMBLY - ROTOR (S.N. 0001 THRU 0005)**

<b>ITEM</b>	<b>PART</b>	<b>QTY.</b>	<b>PART DESCRIPTION</b>
1	2000514	2	BRG\PB\1-3/4\2BOLT\MALLEABLE
2	3800043	1	FTG\LUB\1/8MPXZRK\SHORT
3	4800018	4	BOLT\HEX\1/2X1-1/4
4	4800251	3	BOLT\HEX\1/2X2-1/4\NC
5	4800598	40	BOLT\HEX\5/8X4\NF\GR8
6	4900001	7	NUT\HEX\1/2\NC
7	4900002	1	NUT\HEX\3/8\NC
8	4900179	40	NUT\TPLCK\RTR\5/8\NF\GR9
9	5000001	2	WASH\FLAT\3/8
10	5000004	3	WASH\FLAT\1/2
11	5000006	7	WASH\LOCK\1/2
12	5200012	40	FLAIL\BB\8
13	6100002	1	SPRING\COMP\.072W\11/16OD\2-1/8LONG
14	7500223	40	BUSH\FLAIL\1-1/4X.687x2-1/8L
15	7501050	2	PLATE\SICKLE
16	8100778	1	BRKT\BRG\REAR\RTR
17	8100876	1	SHLD\BRG\REAR\RTR
18	8100877	1	LATCH\SHLD\BRG\REAR\RTR
19	8100879	1	MNT\SHLD\REAR\BRG\RTR
20	8100890	2	SHM\10GA\BRG\RTR
21	8101849	1	ROTOR\HVY\2655

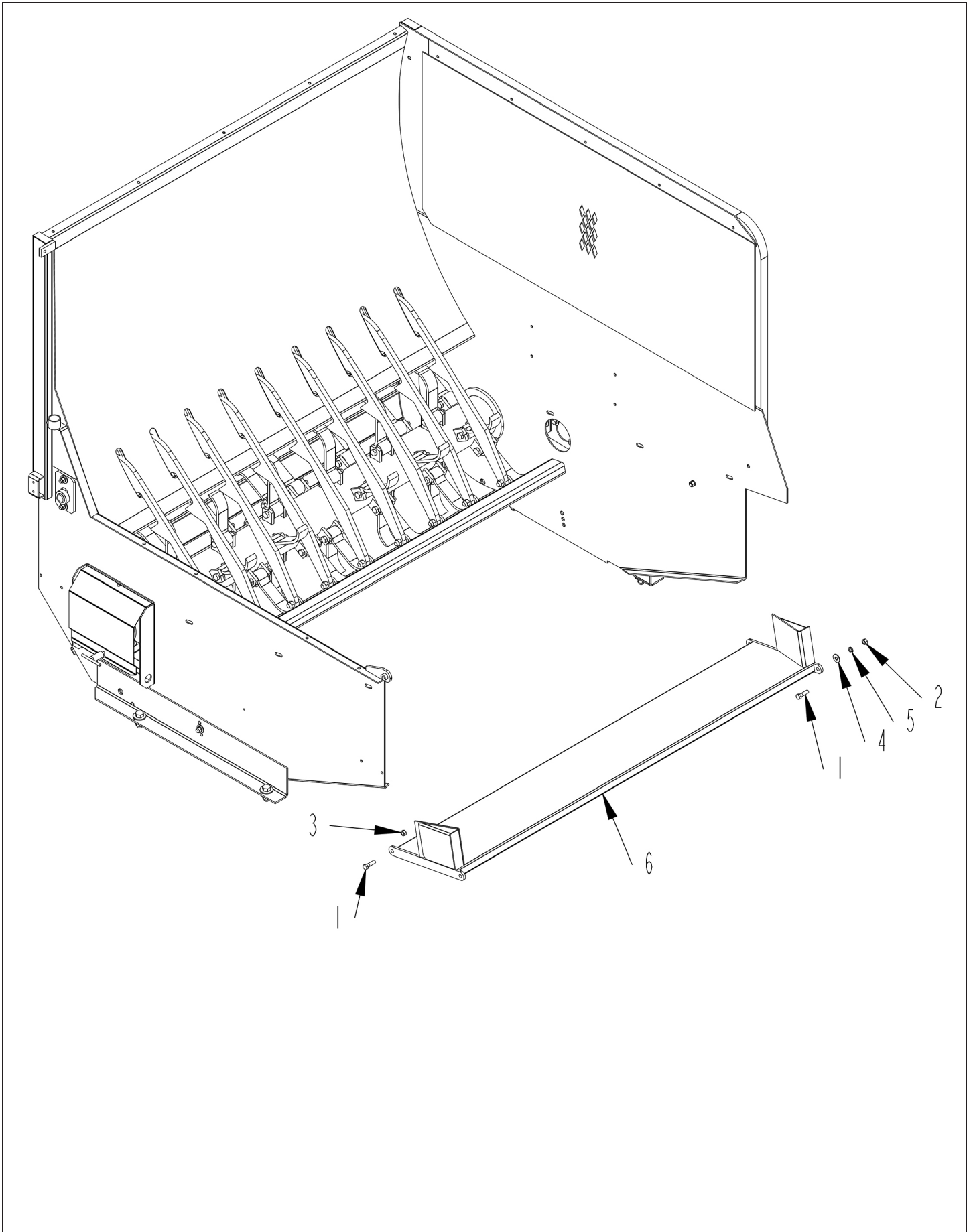
2665 SHREDDER ASSEMBLY - ROTOR (S.N. 0006 AND UP)



**2665 SHREDDER ASSEMBLY - ROTOR (S.N. 0006 AND UP)**

ITEM	PART	QTY.	PART DESCRIPTION
1	2000510	2	BRG\PB\2\2BOLT
2	3800043	2	FTG\LUB\1/8MPXZRK\SHORT
3	4800018	4	BOLT\HEX\1/2X1-1/4
4	4800079	4	BOLT\HEX\5/8X2-1/2
5	4800598	40	BOLT\HEX\5/8X4\NF\GR8
6	4900001	4	NUT\HEX\1/2\NC
7	4900005	4	NUT\HEX\5/8\NC
8	4900023	1	NUT\TPLCK\3/8\NC
9	4900179	40	NUT\TPLCK\RTR\5/8\NF\GR9
10	5000001	1	WASH\FLAT\3/8
11	5000002	8	WASH\FLAT\5/8
12	5000003	4	WASH\LOCK\5/8
13	5000006	4	WASH\LOCK\1/2
14	5200012	40	HMMR\FLAIL\8"HEAVY
15	6100002	1	SPRING\COMP\.072W\11/16OD\2-1/8LONG
16	7500223	40	BUSH\FLAIL\1-1/4X.687x2-1/8L
17	7501050	2	PLATE\SICKLE
18	8100877	1	LATCH\SHLD\BRG\REAR\RTR
19	8100879	1	MNT\SHLD\REAR\BRG\RTR
20	8101462	2	SHM\16GA\BRG\RTR
21	8101631	2	SHM\10GA\BRG\RTR
22	8101891	1	RTR\FLAIL\2"SHFT\HVY
23	8101894	1	BRKT\BRG\2"REAR\RTR
24	8101951	1	SHLD\2"BRG\REAR\RTR

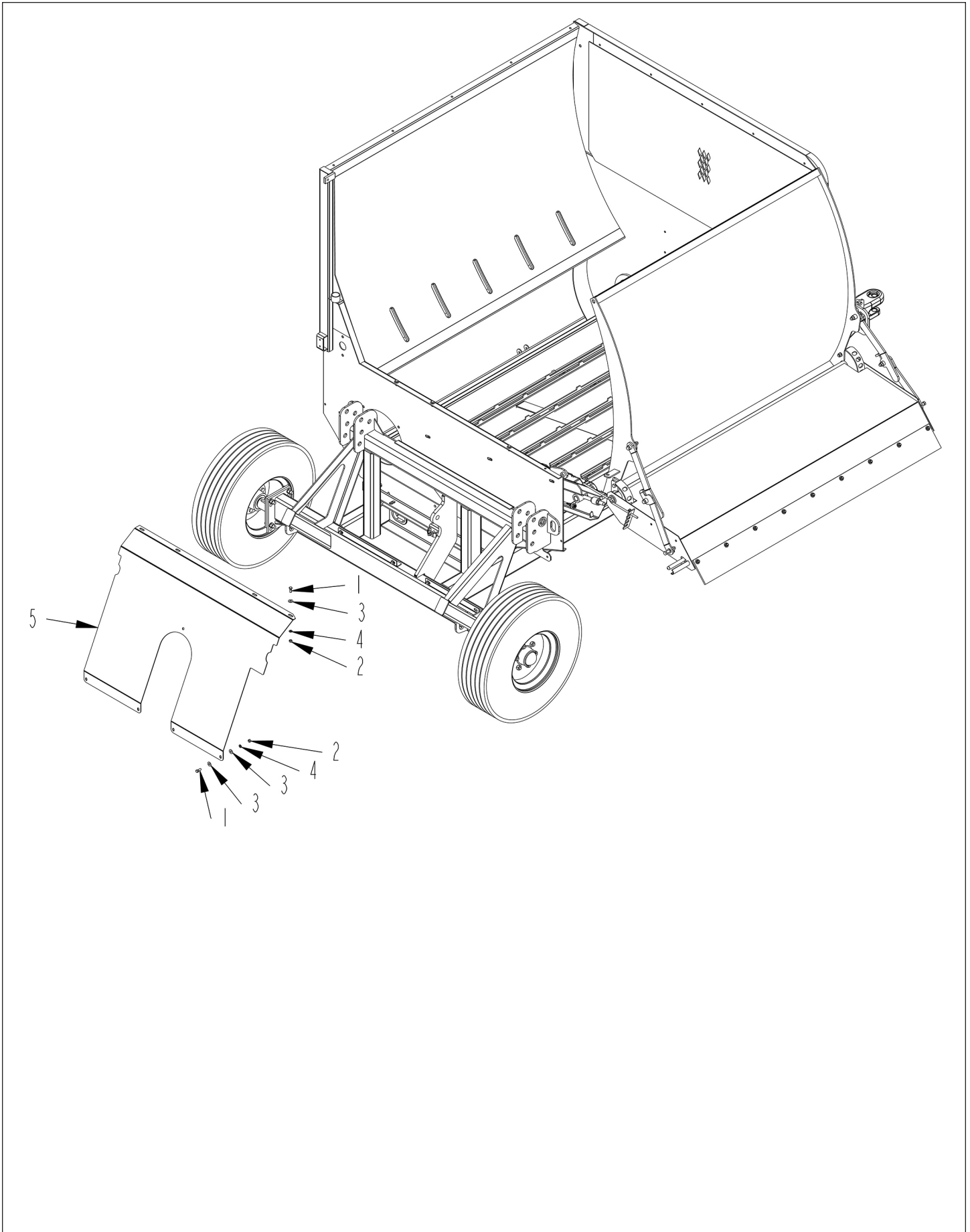
2665 SHREDDER ASSEMBLY - FLOOR PAN



**2665 SHREDDER ASSEMBLY - FLOOR PAN**

<b>ITEM</b>	<b>PART</b>	<b>QTY.</b>	<b>PART DESCRIPTION</b>
1	4800178	4	BOLT\HEX\1/2X1-3/4
2	4900001	2	NUT\HEX\1/2\NC
3	4900014	2	NUT\TPLCK\1/2\NC
4	5000004	2	WASH\FLAT\1/2
5	5000006	2	WASH\LOCK\1/2
6	8101313	1	PAN\DISH\ADJ

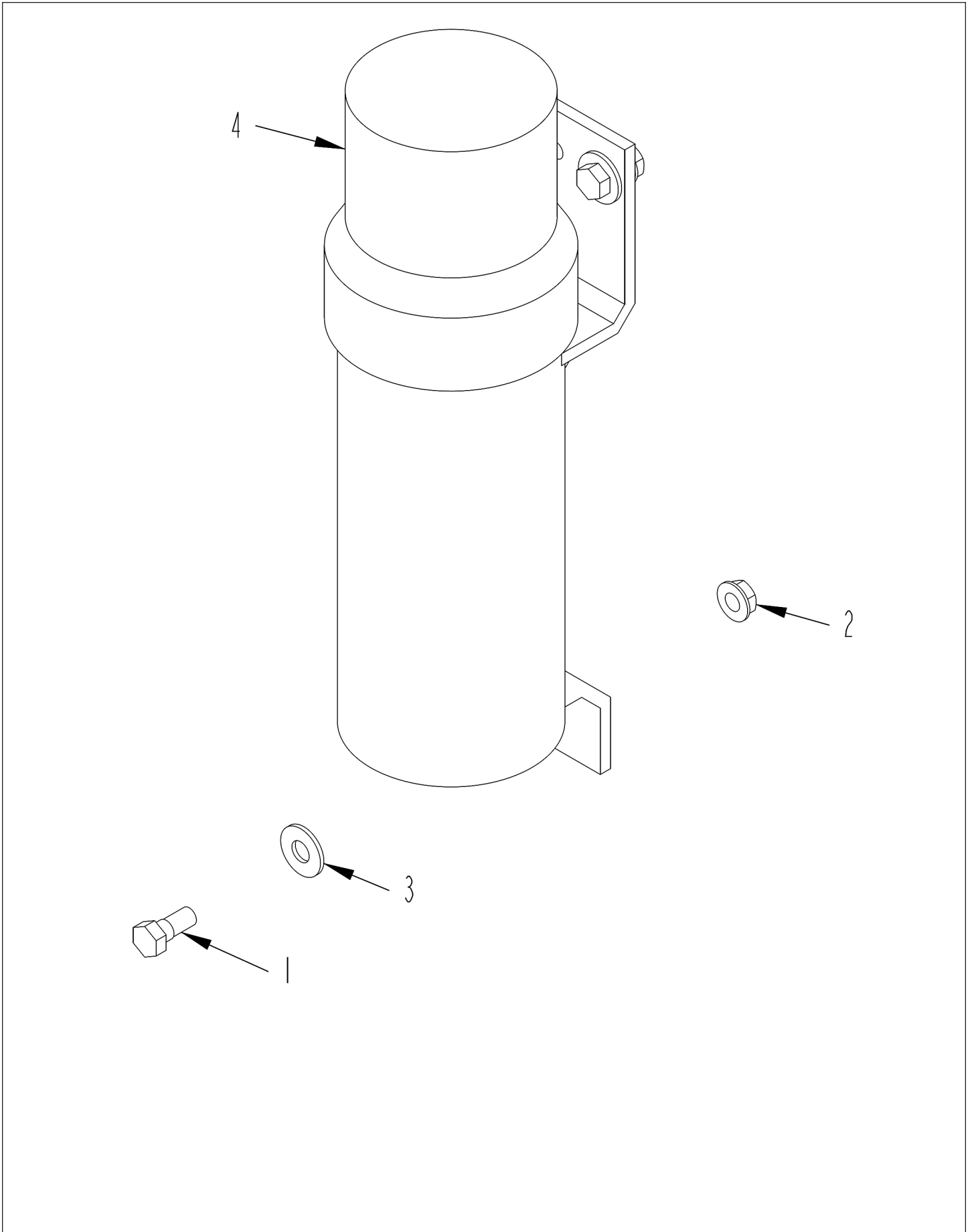
# REAR SHIELD



**REAR SHIELD**

<b>ITEM</b>	<b>PART</b>	<b>QTY.</b>	<b>PART DESCRIPTION</b>
1	4800003	8	BOLT\HEX\3/8X1
2	4900002	8	NUT\HEX\3/8\NC
3	5000001	12	WASH\FLAT\3/8
4	5000019	8	WASH\LOCK\3/8
5	8102051	1	SHLD\REAR\SHRDR\FLL

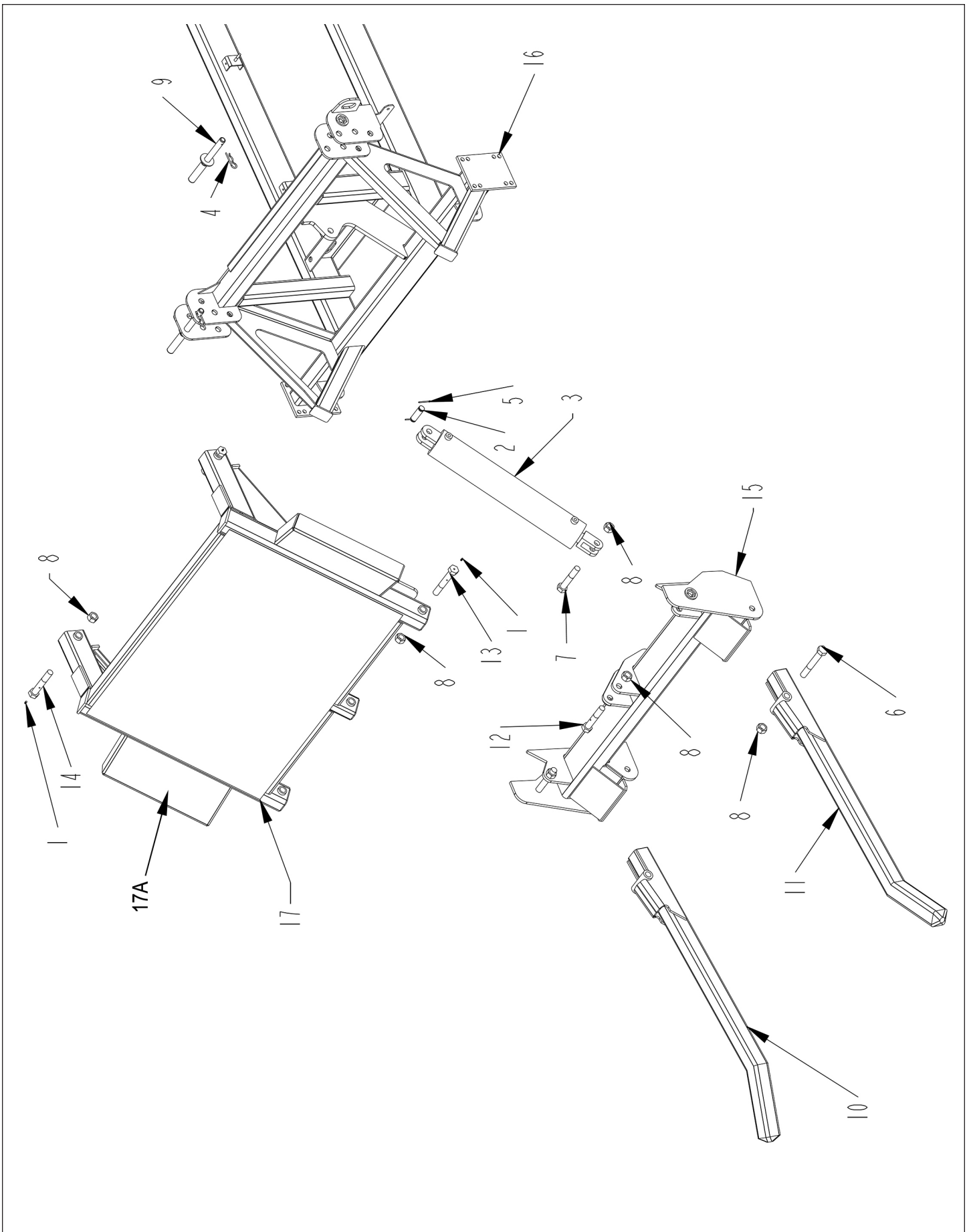
**MANUAL CANISTER ASSEMBLY**



## MANUAL CANISTER ASSEMBLY

ITEM	PART	QTY.	PART DESCRIPTION
1	4800643	3	BOLT\HEX\5/16X3/4
2	4900027	3	NUT\FLG\TPLCK\5/16\NC
3	5000023	3	WASH\FLAT\5/16
4	7501628	1	CNSTRS\MANUAL\12X3.5

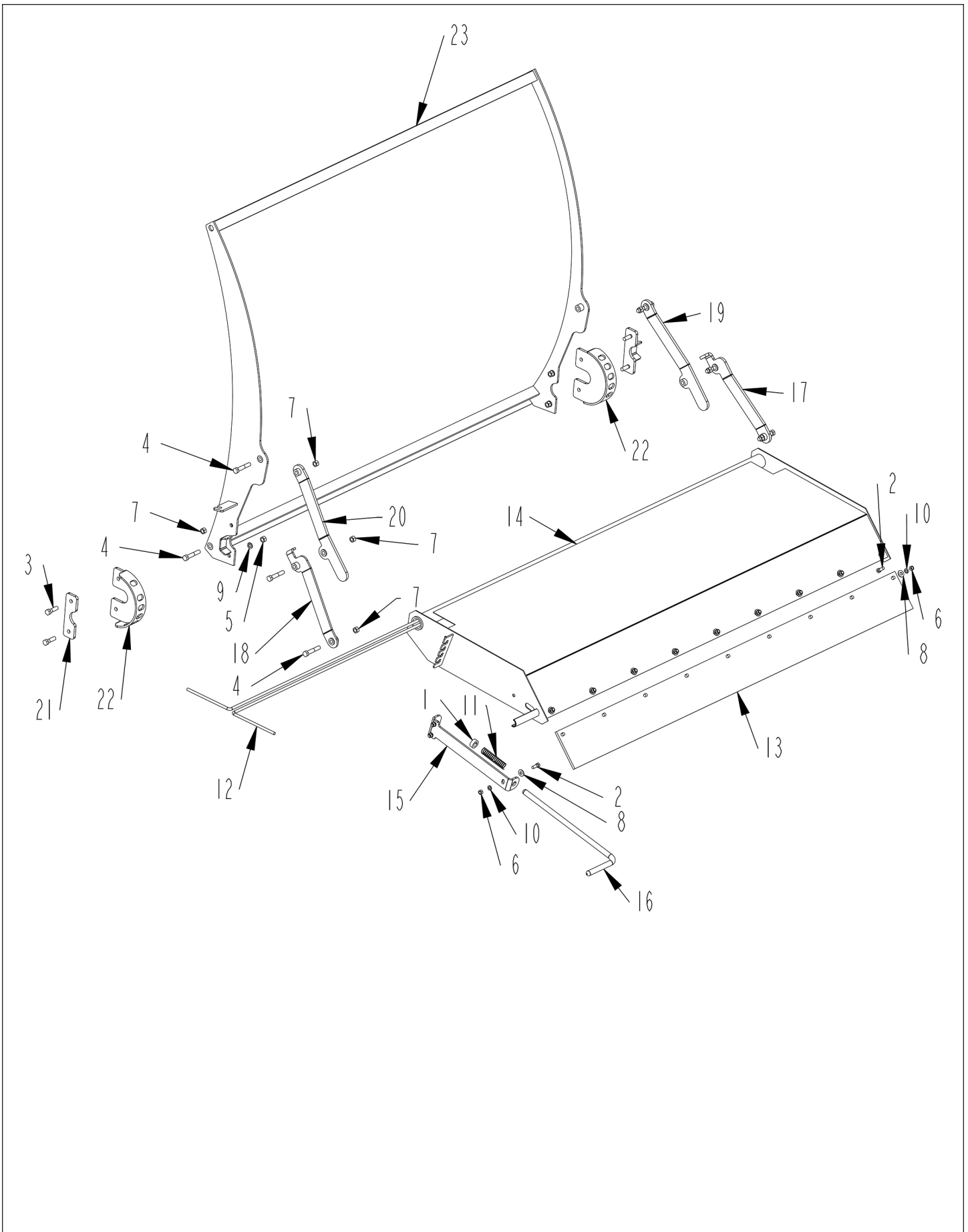
# LOADER MOUNT AND TINES ASSEMBLY



**LOADER MOUNT AND TINES ASSEMBLY**

<b>ITEM</b>	<b>PART</b>	<b>QTY.</b>	<b>PART DESCRIPTION</b>
1	3800082	5	FTG\LUB\1/4NFXZERK\ADAPT
2	4100030	1	PIN 1" X 3-1/2" HYD. CYL.
3	4100273	1	CYL\HYD\4-1/2X24\1-3/4 ROD\1"PINWELD\3/4 O-RING
4	4800056	2	PIN\HAIR\3/16(#3)
5	4800203	2	PIN\COT\5/32X2
6	4800471	2	BOLT\HEX\1X7\NC
7	4800633	1	BOLT\HEX\1X5-1/2\NC\GR5\PLT
8	4900127	8	NUT\TPLCK\1\NC
9	8100794	2	PIN\LOCK\TRANSPORT
10	8101033	1	TINE\SQ\LEFTHAND
11	8101075	1	TINE\SQ\RIGHTHAND
12	8101311	1	BOLT\HEX\1X5-1/2\GREASE
13	8101312	2	BOLT\HEX\1X6-1/2\GREASE
14	8101352	2	BOLT\HEX\1X6\GREASE
15	8101513	1	LOWER\LOADER
16	8101874	1	MNFRM\2660
17	8101875	1	LOADER\UPPER\
17A	D1031475	2	WING\LOADER\2660

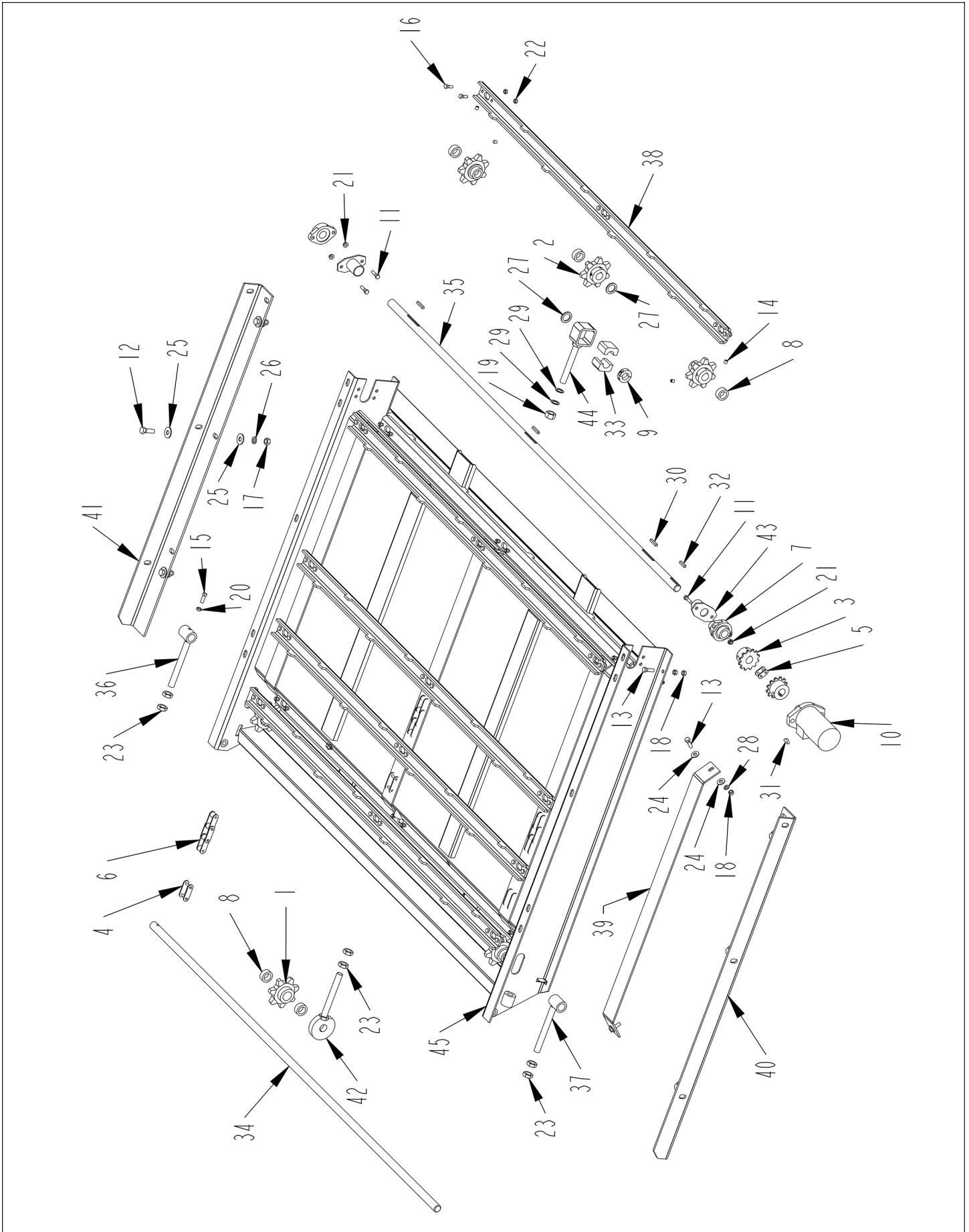
# RACK AND DEFLECTOR ASSEMBLY



## RACK AND DEFLECTOR ASSEMBLY

ITEM	PART	QTY.	PART DESCRIPTION
1	2000811	1	CLLR\LOCK\3/4
2	4800003	12	BOLT\HEX\3/8X1
3	4800178	4	BOLT\HEX\1/2X1-3/4
4	4800351	8	BOLT\HEX\1/2X2-3/4
5	4900001	4	NUT\HEX\1/2\NC
6	4900002	12	NUT\HEX\3/8\NC
7	4900014	8	NUT\TPLCK\1/2\NC
8	5000001	10	WASH\FLAT\3/8
9	5000006	4	WASH\LOCK\1/2
10	5000019	12	WASH\LOCK\3/8
11	6100031	2	SPRING\COMP\.072W\25/32OD
12	6100075	1	BRKT\TORSION\DFLCRT
13	8100791	1	BELT\DFLCTR\6X73-3/4
13A	8100819	opt	BELT\DEFL\18X73-3/4
14	8101046	1	DFLCTR\REAR LATCH\2002
15	8101087	1	BRKT\LATCH\DFLCTR
16	8101088	1	ROD\LATCH\DFLCTR
17	8101090	1	BRKT\STRAP\RACKW-STOP\FRONT
18	8101091	1	BRKT\STRAP\RACKW-STOP\REAR
19	8101092	1	BRKT\STRAP\RACK\FRONT
20	8101093	1	BRKT\STRAP\RACK\REAR
21	8101145	2	MNT\DFLCTR
22	8101146	2	MNT\DFLCTR\W-INDEX
23	8101859	1	RACK

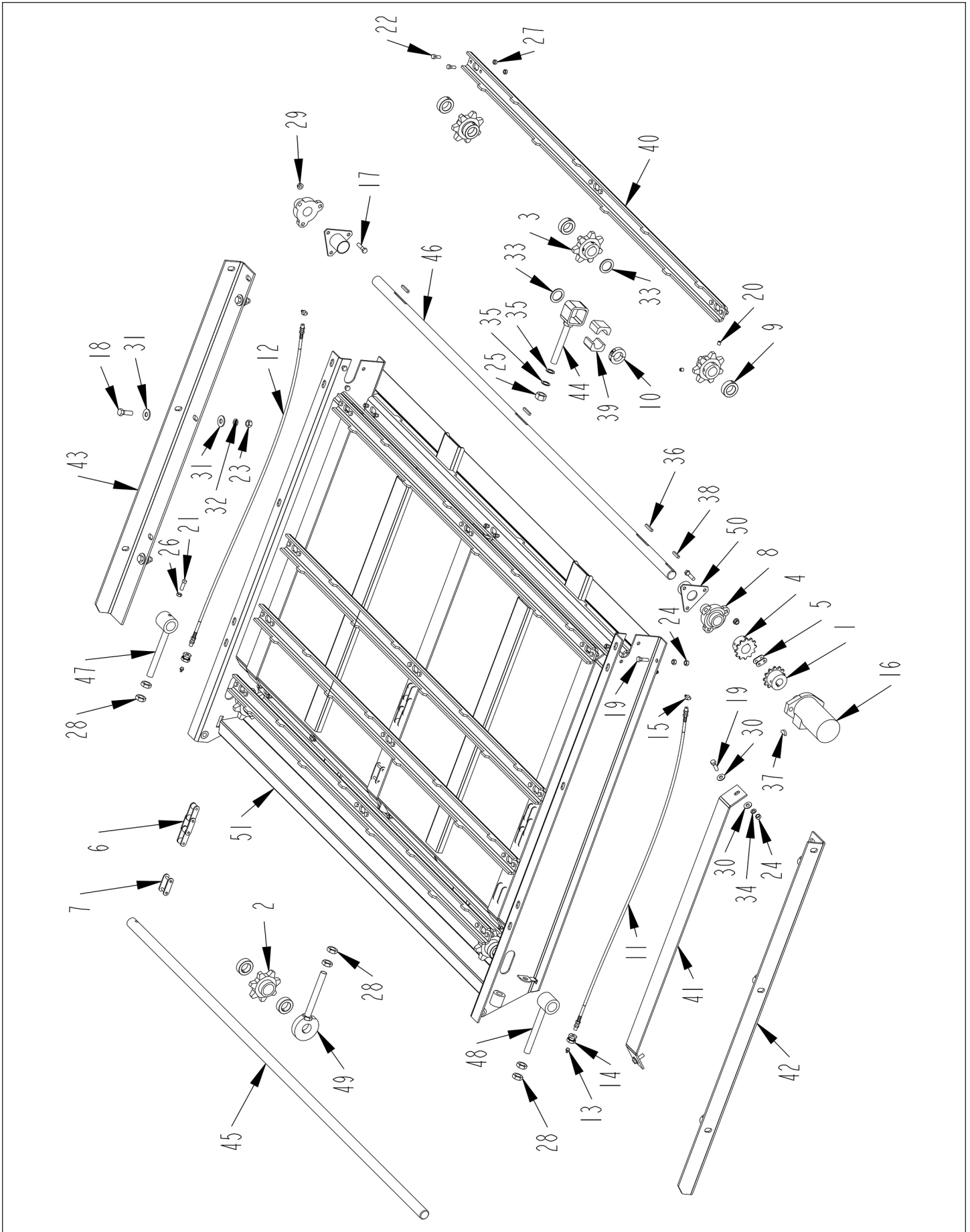
2660 CONVEYOR ASSEMBLY (S.N. 0001 THRU 0005)  
 2665 CONVEYOR ASSEMBLY (S.N. 0001 THRU 0005)



**2660 CONVEYOR ASSEMBLY (S.N. 0001 THRU 0005)**  
**2665 CONVEYOR ASSEMBLY (S.N. 0001 THRU 0005)**

ITEM	PART	QTY.	PART DESCRIPTION
1	1000088	3	SPKT\662\7\1\IDLER\CA
2	1000089	3	SPKT\662\7\1\1/4KWDR
3	1000233	2	SPKT\60\B\12\1\1/4KW
4	1100103	3	CHAIN\620CA\CL
5	1100240	1	CHAIN\60\12\CPLNG\W-CL
6	1100304	3	CHAIN\620CA\59\W/ATTCH
7	2000310	2	BRG\FLG\CAST\1\2BOLT
8	2000809	11	CLLR\SHFT\1\SET
9	2000826	1	CLLR\SHFT\1\TWO-PIECE
10	3900025	1	MOTOR\HYD\17.9\H
11	4800071	4	BOLT\HEX\5/16X1-1/4
12	4800082	6	BOLT\HEX\1/2X1-1/2
13	4800098	6	BOLT\HEX\3/8X1-1/4\NC
14	4800143	6	SCR\SET\ALN\3/8X3/8\NC
15	4800307	1	SCR\SET\SQ\3/8X1\NC
16	4800393	60	BOLT\HEX\5/16X7/8\GR8
17	4900001	6	NUT\HEX\1/2\NC
18	4900002	8	NUT\HEX\3/8\NC
19	4900004	1	NUT\HEX\3/4\NC
20	4900026	1	NUT\JAM\3/8\NC
21	4900027	4	NUT\FLG\TPLCK\5/16\NC
22	4900099	60	NUT\TPLCK\5/16\GR8\NC
23	4900104	8	NUT\JAM\3/4\NC
24	5000001	8	WASH\FLAT\3/8
25	5000004	12	WASH\FLAT\1/2
26	5000006	6	WASH\LOCK\1/2
27	5000018	2	WASH\FLAT\1\10GA\1-1/2 O.D.
28	5000019	4	WASH\LOCK\3/8
29	5000041	2	WASH\3/4ID\1-1/8OD\16GA
30	6200005	3	KEY\SQ\1/4X1-1/2
31	6200011	1	KEY\WDF\1/4X1
32	6200014	1	KEY\SQ\1/4X1-1/4
33	7501506	2	BRG\NYLTRN\1\HALF\1"ID\2SQ-OD
34	8100779	1	SHFT\IDLER\CNVYR
35	8100780	1	SHFT\DRIVE\76\CNVYR
36	8100783	1	BRKT\SHAFT\IDLER\CNVYR
37	8101022	1	BRKT\SHAFT\IDLER\NO-TAP
38	8101053	10	PLT\SLAT\2640
39	8101547	2	PL\RUB\CHAIN\CNVYR
40	8101548	1	MNT\CNVYR\3\BRK
41	8101549	1	MNT\CNVYR\3\BRK
42	8101699	1	MNT\SHFT\CNVYR
43	8101749	2	GUARD\TWINE\CNVYR
44	8101852	1	MNT\BRG\SPLIT\CNVYR
45	8101855	1	FRM\CNVYR\10-SLAT

**2660 CONVEYOR ASSEMBLY (S.N. 0006 & UP)**  
**2665 CONVEYOR ASSEMBLY (S.N. 0006 & UP)**



**2660 CONVEYOR ASSEMBLY (S.N. 0006 & UP)**  
**2665 CONVEYOR ASSEMBLY (S.N. 0006 & UP)**

ITEM	PART	QTY.	PART DESCRIPTION
1	1000233	1	SPKT\60\B\12\1\1\4KW
2	1000306	3	SPKT\662\7\1-1\4\IDLER
3	1000307	3	SPKT\662\7\1-1\4\1\4KW\DRV
4	1000308	1	SPKT\60\B\12\1-1\4\1\4KW
5	1100240	1	CHAIN\60\12\CPLNGW-CL
6	1100313	3	CHAIN\620CA\59\W\ATTCH
7	1100319	3	CHAIN\620CA\CL\HITACHI
8	2000333	2	BRG\FLG\CAST\1-1\4\3-BOLT
9	2000805	11	CLLR\SHFT\1-1\2\SET
10	2000827	1	CLLR\SHFT\1-1\4\TWO-PIECE
11	3701488	1	HOSE\LUB\1\8X43\MPS-MPS
12	3701488	1	HOSE\LUB\1\8X43\MPS-MPS
13	3800043	2	FTG\LUB\1\8MPXZRK\SHORT
14	3800895	2	FTG\1\8FP\CPLG\ANCHOR\5\8NF
15	3801009	2	FTG\LUB\1\4-28MX1\8NPTF\45\ELB
16	3900025	1	MOTOR\HYD\17.9\H (NOT INCLUDED IN 8102042)
17	4800034	6	BOLT\HEX\3\8X1-1\2
18	4800082	6	BOLT\HEX\1\2X1-1\2
19	4800098	6	BOLT\HEX\3\8X1-1\4\NC
20	4800143	6	SCR\SET\ALN\3\8X3\8\NC
21	4800307	1	SCR\SET\SQ\3\8X1\NC
22	4800393	60	BOLT\HEX\5\16X7\8\GR8
23	4900001	6	NUT\HEX\1\2\NC
24	4900002	8	NUT\HEX\3\8\NC
25	4900004	1	NUT\HEX\3\4\NC
26	4900026	1	NUT\JAM\3\8\NC
27	4900099	60	NUT\TPLCK\5\16\GR8\NC
28	4900104	6	NUT\JAM\3\4\NC
29	4900109	6	NUT\FLG\TPLCK\3\8\NC
30	5000001	8	WASH\FLAT\3\8
31	5000004	12	WASH\FLAT\1\2
32	5000006	6	WASH\LOCK\1\2
33	5000007	2	WASH\1-1\4\MACH\BUSH
34	5000019	4	WASH\LOCK\3\8
35	5000041	2	WASH\3\4ID\1-1\8OD\16GA
36	6200005	3	KEY\SQ\1\4X1-1\2
37	6200011	1	KEY\WDF\1\4X1 (NOT INCLUDED IN 8102042)
38	6200005	1	KEY\SQ\1\4X1-1\2
39	7501589	2	BRG\NYLTRN\1-1\4\HALF\2SQ-OD
40	8101053	10	PLT\SLAT\2640
41	8101547	2	PL\RUB\CHAIN\CNVYR
42	8101548	1	MNT\CNVYR\3\BRK
43	8101549	1	MNT\CNVYR\3\BRK
44	8101852	1	MNT\BRG\SPLIT\CNVYR
45	8102030	1	SHFT\IDLER\1-1\4\CNVYR
46	8102031	1	SHFT\DRIVE\1-1\4\CNVYR
47	8102032	1	BRKT\SHAFT\IDLER\CNVYR
48	8102033	1	BRKT\SHAFT\IDLER\NO-TAP\1-1\4
49	8102034	1	SUP\SHFT\IDLER\CNVYR\1-1\4
50	8102035	2	GUARD\TWINE\CNVYR\3HL
51	8102037	1	FRM\CNVYR\1-1\4SHFT\10SLAT

**8102042**

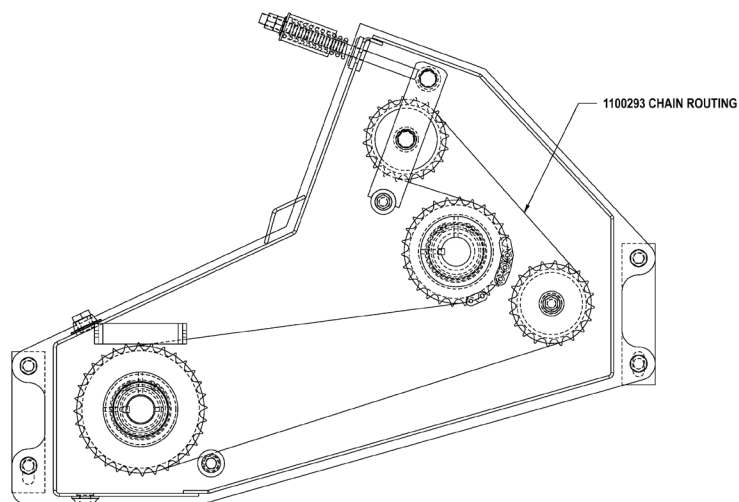
**CNVYR\ASSY\1-1\4SHFT\10-SLAT\COMPLETE**

**2660 DRIVE CHAIN ASSEMBLY (S.N. THRU 0005)**  
**2665 DRIVE CHAIN ASSEMBLY (S.N. THRU 0005)**



**2660 DRIVE CHAIN ASSEMBLY (S.N. THRU 0005)**  
**2665 DRIVE CHAIN ASSEMBLY (S.N. THRU 0005)**

ITEM	PART	QTY.	PART DESCRIPTION
1	1000276	2	SPKT\B\80\15\HT\1\IDLER
2	1000277	1	SPKT\80\B\20\HT\1-3/4\3/8KW
3	1000294	1	SPKT\B\80\26\HT\1-3/4\3/8KW
4	1100162	1	CHAIN\80H\CL
5	1100293	1	CHAIN\80H\97 LINKS
6	2000339	3	BRG\FLG\CAST\PILOTED\1-3/4
7	3700769	1	HOSE\LUB\1/8X23\MP5-MPS
8	3700770	1	HOSE\LUB\1/8X8-1/2\MP5-MPS
9	3800043	2	FTG\LUB\1/8MPXZRK\SHORT
10	3800173	2	FTG\3/8MP\PLUG\HEX
11	3800452	1	FTG\3/4MP\VENT\BREATHER
12	3800895	2	FTG\1/8FP\CPLG\ANCHOR\5/8NF
13	3800896	1	FTG\O-RING\5/8IDX13/16OD
14	4800003	8	BOLT\HEX\3/8X1
15	4800077	2	BOLT\HEX\1/2X5-1/2
16	4800155	4	BOLT\HEX\5/8X7
17	4800178	12	BOLT\HEX\1/2X1-3/4
18	4800904	2	SNSPRNG\EXT\1"
19	4900001	4	NUT\HEX\1/2\NC
20	4900005	5	NUT\HEX\5/8\NC
21	4900014	2	NUT\TPLCK\1/2\NC
22	4900110	1	NUT\FLG\SERR\5/8\NC
23	5000002	2	WASH\FLAT\5/8
24	5000003	4	WASH\LOCK\5/8
25	5000006	12	WASH\LOCK\1/2
26	5000018	1	WASH\FLAT\110GA\1-1/2 O.D.
27	5000019	8	WASH\LOCK\3/8
28	5000051	1	WASH\MACH\1-3/4ID\10GA\PL
29	6100076	1	SPRING\1-1/4 O.D. X 3-3/4 LONG X 3/16 WIRE X 10 COILS
30	6200008	2	KEY\SQ\3/8X2
31	8101043	1	BRKT\IDLER\CHAIN\DRIVE
32	8101077	2	RUBBER\CUSHION
33	8101078	1	BRKT\LIMIT\SPRING
34	8101079	1	ROD\IDLER\CONTROLL
35	8101080	2	BRKT\MNT\CHAIN\DRIVE
36	8101081	1	SHLD\HSG\DRV\PTO
37	8101084	2	MNT\IDLER\DRV\PTO
38	8101307	2	RING\MNT\BRG
39	8101309	1	CASE\CHAIN
40	8101709	1	TUBE\SPCR\DRV\PTO
41	8101710	1	BRKT\IDLER\DRV\PTO
42	8101712	1	SHFT\DRV\CHAIN\PTO
43	8101789	1	TUBE\SPCR\DRV\PTO
44	8101790	2	TUBE\IDLER\DRV\PTO
45	8101791	1	TUBE\IDLER\DRV\PTO



**DRIVE CHAIN ASSEMBLY - CHAIN ROUTING**  
 2660/2665 BALEBUSTER PARTS REFERENCE

**2660 DRIVE CHAIN ASSEMBLY (S.N. 0006 AND UP)**  
**2665 DRIVE CHAIN ASSEMBLY (S.N. 0006 AND UP)**

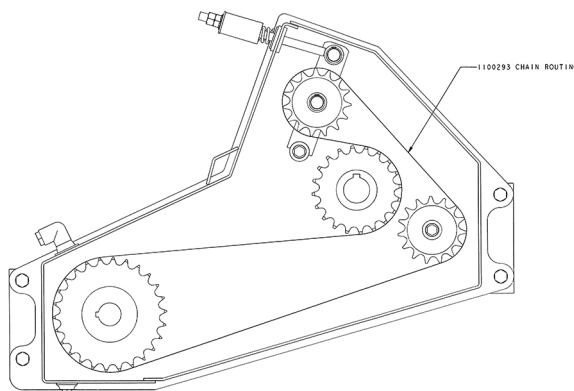


**2660 DRIVE CHAIN ASSEMBLY (S.N. 0006 AND UP)**  
**2665 DRIVE CHAIN ASSEMBLY (S.N. 0006 AND UP)**

ITEM	PART	QTY.	PART DESCRIPTION
1	1000276	2	SPKT\B\80\15\HT\1\IDLER
2	1000294	1	SPKT\B\80\26\HT\1-3/4\3/8KW
3	1000301	1	SPKT\B\80\20\HT\2\1/2KW
4	1100162	1	CHAIN\80H\1CL
5	1100293	1	CHAIN\80H\103 LINKS
6	2000339	2	BRG\FLG\CAST\PILOTED\1-3/4
7	2000340	1	BRG\FLG\CAST\PILOTED\2
8	3700769	1	HOSE\LUB\1/8X23\MP5-MPS
9	3700770	1	HOSE\LUB\1/8X8-1/2\MP5-MPS
10	3800043	2	FTG\LUB\1/8MPXZRK\SHORT
11	3800129	1	FTG\3/4MPX3/4FP\90\ST;EL
12	3800173	2	FTG\3/8MP\PLUG\HEX
13	3800452	1	FTG\3/4MP\VENT\BREATHER
14	3800895	2	FTG\1/8FP\CPLG\ANCHOR\5/8NF
15	3800896	1	FTG\O-RING\5/8IDX13/16OD
16	4800003	8	BOLT\HEX\3/8X1
17	4800077	2	BOLT\HEX\1/2X5-1/2
18	4800155	4	BOLT\HEX\5/8X7 (S.N. 0006 THRU 0010)
18A	4800144		BOLT\HEX\5/8X6-1/2 (S.N. 0011 & UP)
19	4800178	12	BOLT\HEX\1/2X1-3/4
20	4800904	2	SNSPRNG\EXT\1"
21	4900001	4	NUT\HEX\1/2\NC
22	4900005	5	NUT\HEX\5/8\NC
23	4900014	2	NUT\PLCK\1/2\NC
24	4900110	1	NUT\FLG\SERR\5/8\NC
25	5000002	2	WASH\FLAT\5/8
26	5000003	4	WASH\LOCK\5/8
27	5000006	12	WASH\LOCK\1/2
28	5000018	1	WASH\FLAT\1\10GA\1-1/2 O.D.
29	5000019	8	WASH\LOCK\3/8
30	5000051	1	WASH\MACH\1-3/4ID\10GA\PL
31	6100076	1	SPRING\1-1/4ODX3-3/4 LX3/16WX10
32	6200008	1	KEY\SQ\3/8X2
33	7000345	1	KEY\SQ\1/2X2
34	8101043	1	BRKT\IDLER\CHAIN\DRIVE
35	8101077	2	RUBBER\CUSHION
36	8101078	1	BRKT\LIMIT\SPRING
37	8101079	1	ROD\IDLER\CONTROLL
38	8101081	1	SHLD\HSG\DRV\PTO
39	8101084	2	MNT\IDLER\DRV\PTO
40	8101116	1	BRKT\SPACER\IDLER\GRBX
41	8101307	2	RING\MNT\BRG
42	8101636	2	SPCR\MNT\CHAIN\DRIVE\3/4 (S.N. 0006 THRU 0010)
42A	8101344		SPCR\MNT\CHAIN\DRIVE\10GA (S.N. 0011 & UP)
43	8101712	1	SHFT\DRV\CHAIN\PTO
44	8101898	1	CASE\CHAIN\2" BRG
45	8101899	2	BRKT\IDLER\DRV\PTO
46	8101900	1	TUBE\SPCR\DRV\PTO

**8101897**

**HSG\CHAIN\FLG-BRG\2" SHFT-OUT\COMPLETE**



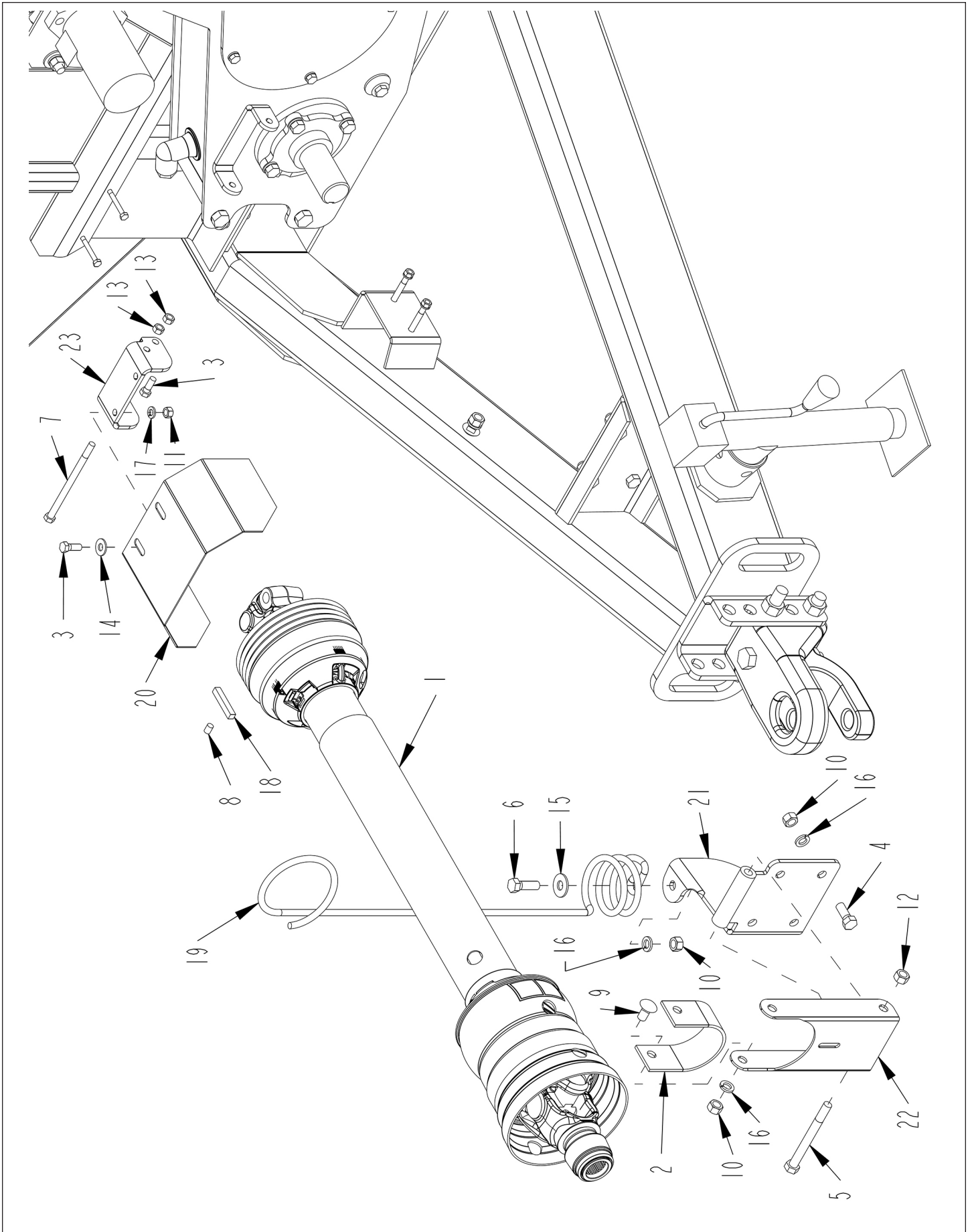
**DRIVE CHAIN ASSEMBLY - CHAIN ROUTING**



**STANDARD DRIVE LINE ASSEMBLY**

<b>ITEM</b>	<b>PART</b>	<b>QTY.</b>	<b>PART DESCRIPTION</b>
	<b>8101826</b>		<b>DRV\ASSY\STD</b>
1	2000514	1	BRG\PB\1-3/4\2BOLT\MALLEABLE
2	3600453	1	JOINT\44\1-3/4BORE\ASSY
3	3600459	1	PTO\252-21797\44R
4	4800003	2	BOLT\HEX\3/8X1
5	4800044	1	PIN\COT\5/32X1-1/2
6	4800068	2	BOLT\HEX\1/2X3
7	4800082	1	BOLT\HEX\1/2X1-1/2
8	4800210	1	BOLT\HEX\3/8X6
9	4800251	2	BOLT\HEX\1/2X2-1/4\NC
10	4800592	4	BOLT\HEX\1/2X3-1/4
11	4900001	3	NUT\HEX\1/2\NC
12	4900002	3	NUT\HEX\3/8\NC
13	4900014	6	NUT\TPLCK\1/2\NC
14	5000001	2	WASH\FLAT\3/8
15	5000004	8	WASH\FLAT\1/2
16	5000006	3	WASH\LOCK\1/2
17	5000019	19	WASH\LOCK\3/8
18	6100028	4	2-1/4 COMP SPR.125 X .725
19	6100031	1	SPRING\COMP\.072W\25/32OD
20	6200020	3	KEY\SQ\3/8X2-1/4\HARDEND
21	7500170	1	HOSE MINDER
22	8101071	1	LATCH\SHLD
23	8101072	1	SHLD\PTO
24	8101073	1	BRKT\BRG\PTO\2650
25	8101074	1	SHFT\DRV\PTO
26	8101076	1	MNT\SHLD\DRV

# CONSTANT VELOCITY DRIVE LINE ASSEMBLY

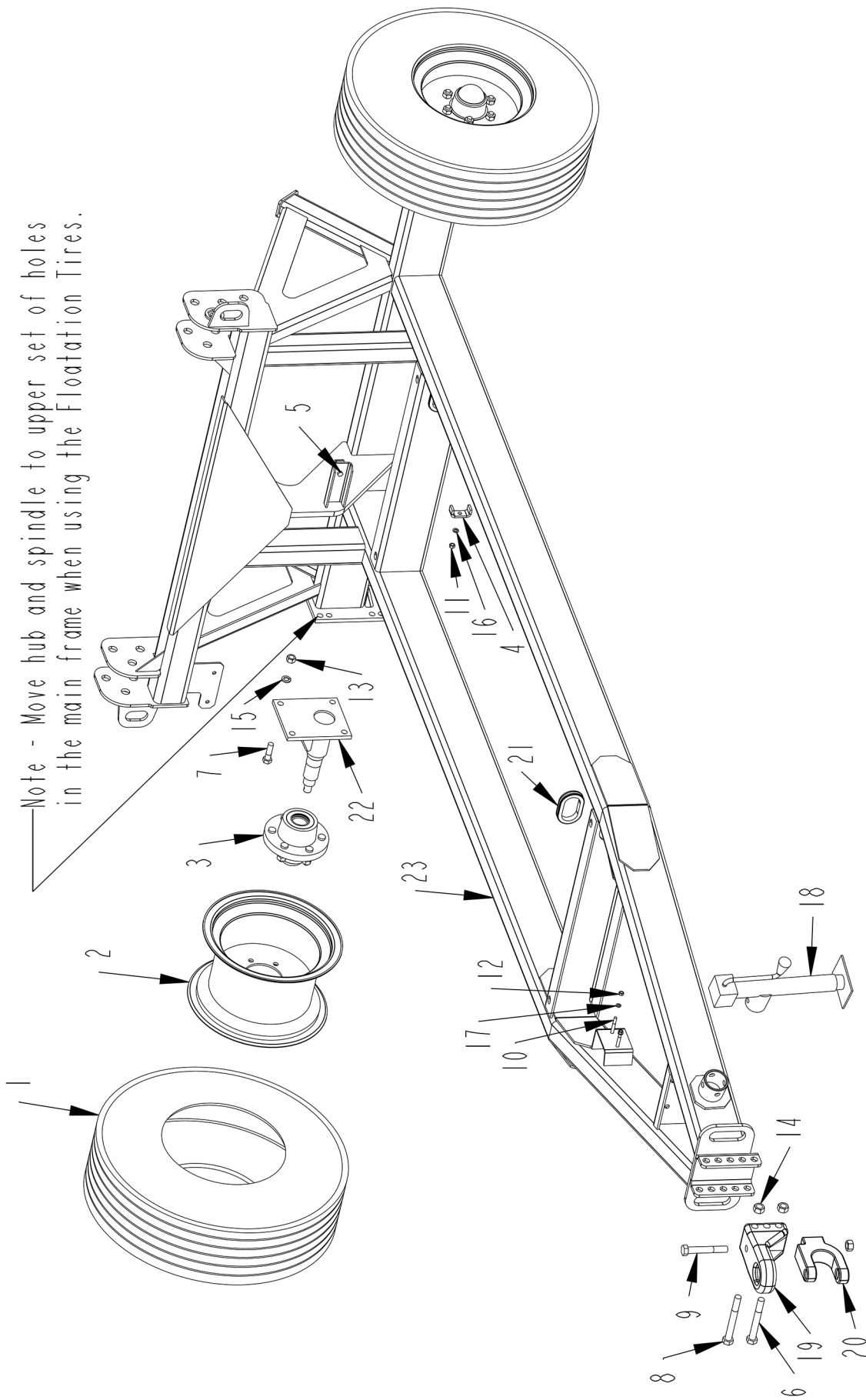


**CONSTANT VELOCITY DRIVE LINE ASSEMBLY**

<b>ITEM</b>	<b>PART</b>	<b>QTY.</b>	<b>PART DESCRIPTION</b>
	<b>8101827</b>		<b>DRV\ASSY\CV</b>
1	3600684	1	PTO\44E\CAT5\80CV\21SP\1-3/8>
2	4500754	1	BELT\BRKT\PTO
3	4800003	4	BOLT\HEX\3/8X1
4	4800018	4	BOLT\HEX\1/2X1-1/4
5	4800041	1	BOLT\HEX\1/2X5
6	4800082	1	BOLT\HEX\1/2X1-1/2
7	4800210	1	BOLT\HEX\3/8X6
8	4800356	1	SCR\SET\ALN\3/8X1/2\NC
9	4800908	2	BOLT\CRG\1/2X1
10	4900001	7	NUT\HEX\1/2\NC
11	4900002	2	NUT\HEX\3/8\NC
12	4900014	1	NUT\TPLCK\1/2\NC
13	4900023	3	NUT\TPLCK\3/8\NC
14	5000001	2	WASH\FLAT\3/8
15	5000004	1	WASH\FLAT\1/2
16	5000006	7	WASH\LOCK\1/2
17	5000019	2	WASH\LOCK\3/8
18	6200020	1	KEY\SQ\3/8X2-1/4\HARDEND
19	7500170	1	HOSE MINDER
20	8101795	1	SHLD\PTO
21	8101796	1	MNT\HOSEMINDER\MNFRM
22	8101803	1	BRKT\PTO
23	8101825	1	MNT\SHLD\DRV

# MAIN FRAME ASSEMBLY

Note - Move hub and spindle to upper set of holes in the main frame when using the Floatation Tires.



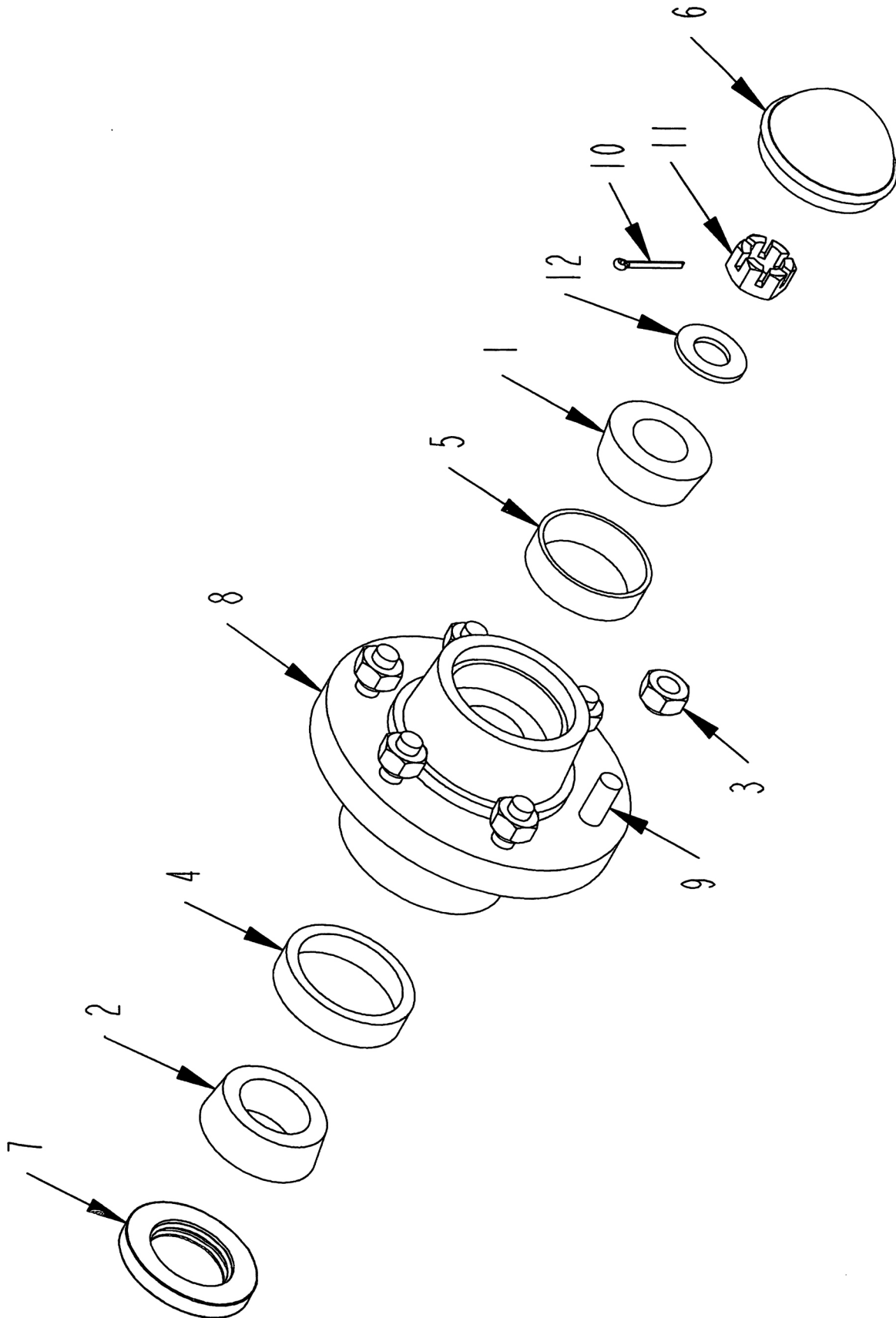
**MAIN FRAME ASSEMBLY**

ITEM	PART	QTY.	PART DESCRIPTION
			<b>HIGHWAY RATED TIRES</b>
	2600823		WHL\HWY\31X10.5X15\TIRE&RIM
1	2600041	2	TIRE\31X10.5X15\LOAD;C
2	2600624	2	WHL\6-BOLT\15"X10"
			<b>FLOTATION TIRES</b>
	2600848		WHL\IMP\1_ASSY\14LX16.1
1	2600846	2	TIRE\14LX16.1\8PLY
2	2600652	2	WHL\6-BOLT\16.1X11
			<b>KNOBBY TIRES</b>
	2600877		WHL\KNOBBY\TIRE&RIM\14X17.5\6BOLT>
1	2600058		TIRE\13.5X16.1\KNOBBY
2	2600654		RIM\6-BOLT\
3	2900171	2	HUB\6-BOLT\STUDS\COMPLETE
4	4700777	4	CLMP\HOSE\1/2
5	4800146	4	BOLT\HEX\3/8X2
6	4800248	1	BOLT\HEX\3/4X6
7	4800350	8	BOLT\HEX\5/8X2-1/4
8	4800382	1	BOLT\HEX\3/4X6-1/2
9	4800562	1	BOLT\HEX\3/4X5\GR8\NC
10	4800570	2	BOLT\HEX\5/16X2-1/2
11	4900002	4	NUT\HEX\3/8\NC
12	4900003	2	NUT\HEX\5/16\NC
13	4900005	8	NUT\HEX\5/8\NC
14	4900139	3	NUT\TPLCK\3/4\GR8\NC
15	5000003	8	WASH\LOCK\5/8
16	5000019	4	WASH\LOCK\3/8
17	5000022	2	WASH\LOCK\5/16
18	5800632	1	JACK\5000LB\15"\SWIVEL-STYLE
19	7501047	1	HITCH\BASE\#3\PPI\1"PIN
20	7501048	1	HITCH\CLEVIS\PPI\1"PIN
21	7501069	2	GRMT\RBBR\2X1.75ID\1/4T
22	8101828	2	SPNDL\BOLT-ON
23	8101874	1	MNFRM\2660

**NOT SHOWN**

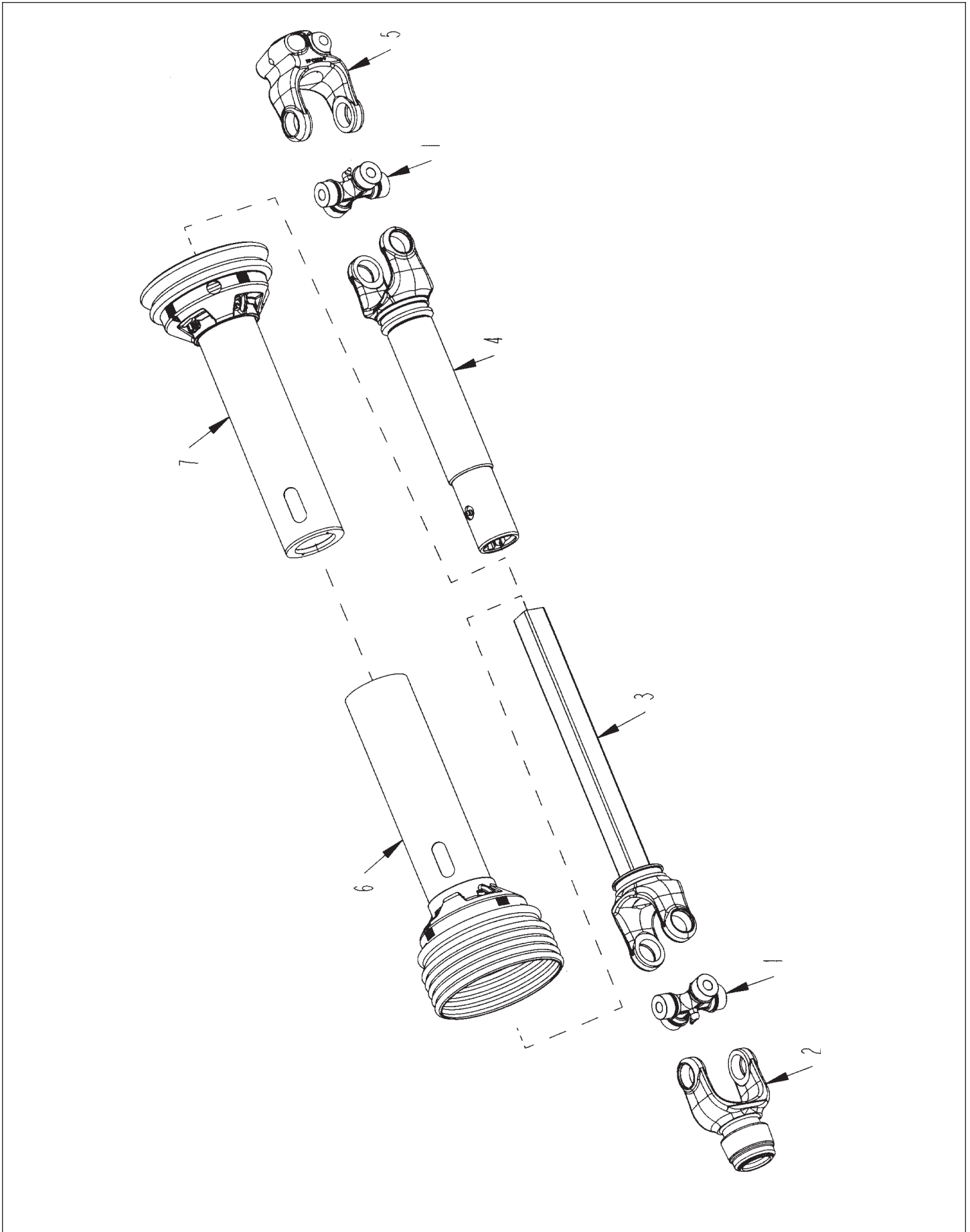
	1100275	1	CHAIN\1/4\SFTYAG\11000LB
	5000005	1	WASH\FLAT\3/4
	5000030	1	WASH\FLAT\13/16\2OD\1/4T

2660 WHEEL AND BEARING  
2665 WHEEL AND BEARING



**2660 WHEEL AND BEARING****2665 WHEEL AND BEARING**

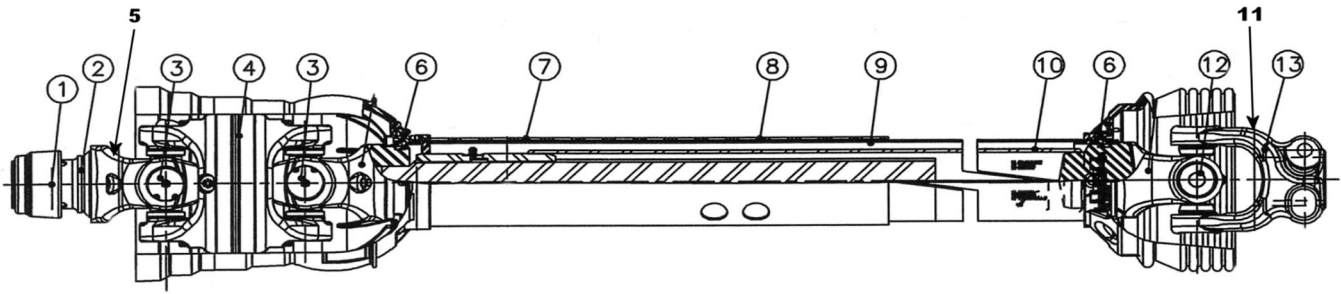
<b>ITEM</b>	<b>PART</b>	<b>QTY.</b>	<b>PART DESCRIPTION</b>
1	2900024	1	CONE\BRG\OUTER\25877
2	2900029	1	CONE INNER/WHEL HUB\25590
3	2900083	6	NUT\TAPER\WHEEL\1/2\NF\
4	2900164	1	BRG\CUP\INNER\875\25520
5	2900165	1	BRG\CUP\OUTER\875\25821
6	2900168	1	CAP\DUST\875
7	2900169	1	SEAL\GREASE\875\P602110
8	2900171	1	HUB\6-BOLT\STUDS\COMPLETE (INCLUDES ITEMS 1, 2, 3, 4, 5, 6, 7, 9)
9	2900172	6	STUD\WHL\9/16-18X2-1/8\GR5\P151403
10	4800044	1	PIN\COT\5/32X1-1/2
11	4900054	1	NUT\CASTLE\1/2\NF
12	5000055	1	WASH\SPINDLE\7/8



**PTO ASSEMBLY #3600459**

<b>ITEM</b>	<b>PART</b>	<b>QTY.</b>	<b>PART DESCRIPTION</b>
	<b>3600459</b>		<b>PTO\252-21797\44R</b>
1	3600115	2	440 CROSS AND BEARING KIT
2	3600363	1	SLIDE LOCK YOKE ASSY
3	3600364	1	YOKE & SHAFT 3600334
4	3600368	1	YOKE,TUBE,SLIP SLEEVE
5	3600369	1	YOKE 36-334
6 & 7	3600460	1	GUARD\SET\PTO\3600459
	3600453		JOINT\44\1-3/4BORE\ASSY (INCLUDES: 1&5
	3600462		JOINT & SHAFT ASM W-GUARD (INCLUDES: 1,2,3,6)
	3600463		JOINT & TUBE ASY W-GUARD (INCLUDES: 1,4,5,7)
	3600271		SAFETY SLD LCK REPAIR KIT for 3600363
	3600489		NYLON\REPAIR\KIT

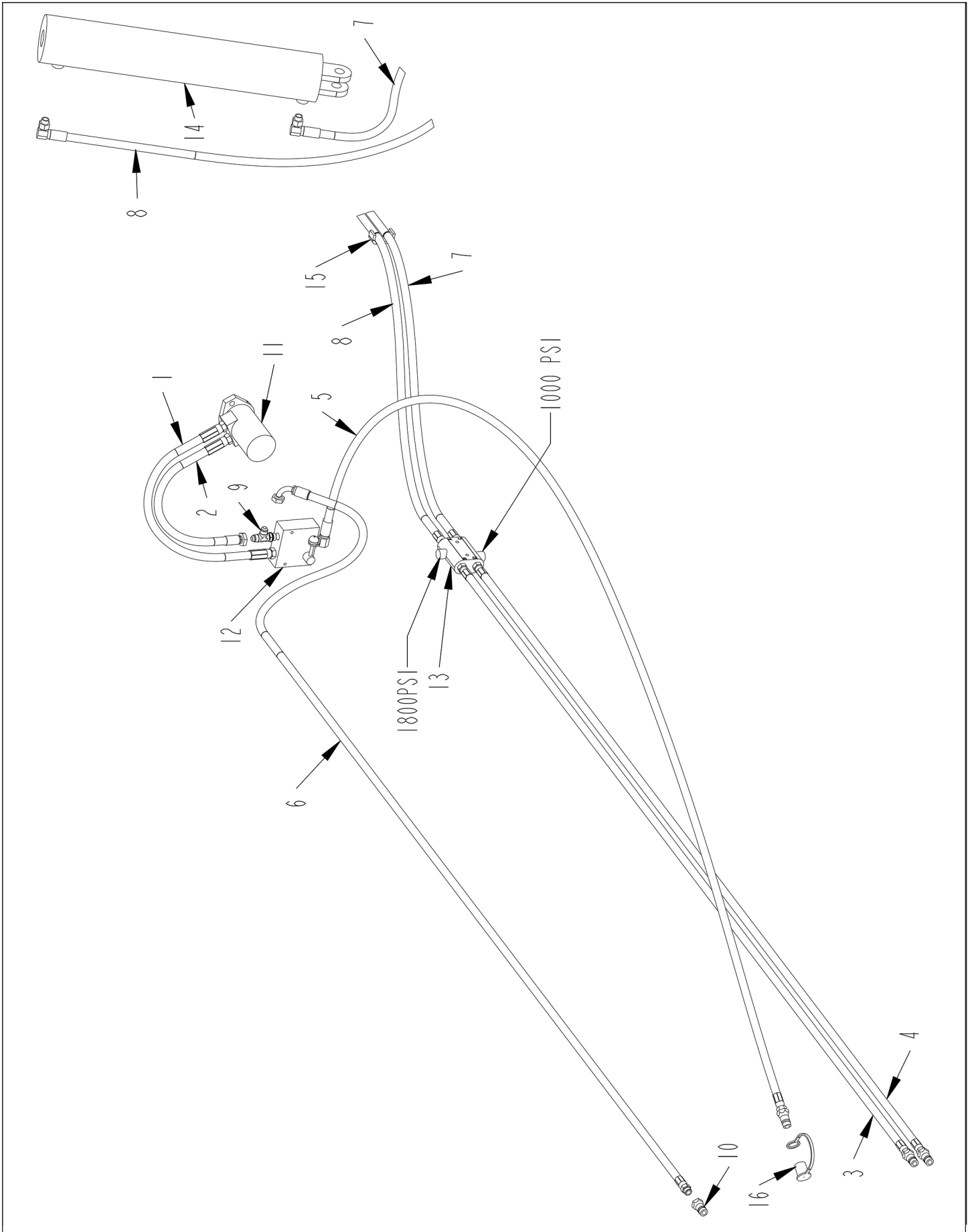
**PTO ASSEMBLY #3600684**



**PTO ASSEMBLY #3600684**

<b>ITEM</b>	<b>PART</b>	<b>QTY.</b>	<b>PART DESCRIPTION</b>
1	3600271	1	LOCK\SAFTY;SLID\KIT\1-3/8
2	3600763	1	YOKE\CAT6\WWCV\1-3/8-21\AL
2A	3600782	OPTION	YOKE\44E\WWCV\1-3/4\20SP\AL
3	3600764	2	CROSS&BRG\CAT6\80DEG\CV
4	3600765	1	CENTER-HOUSING
5	3600869	1	PTO\HALF\TRACTOR\3600684
6	3600489	2	KIT\REP\NYLON\PLSTC;SHLD
7	6500085	1	DECAL\DNGR\ROTATNG;DR-LNE
8	3600761	1	GUARD\OUTER\3600684
9	3600762	1	GUARD\INNER\3600684
10	3600282	1	SAFETY SIGN
11	3600685	1	PTO\HALF\MACHINE\3600684
12	3600604	1	CROSS&BRG\44E\WSLR
13	3600369	1	YOKE 36-334 2544
	<b>3600684</b>		<b>PTO\44E\CAT6\80CV\21SP\1-3/8&gt;</b>

# HYDRAULIC HOSES AND FITTINGS

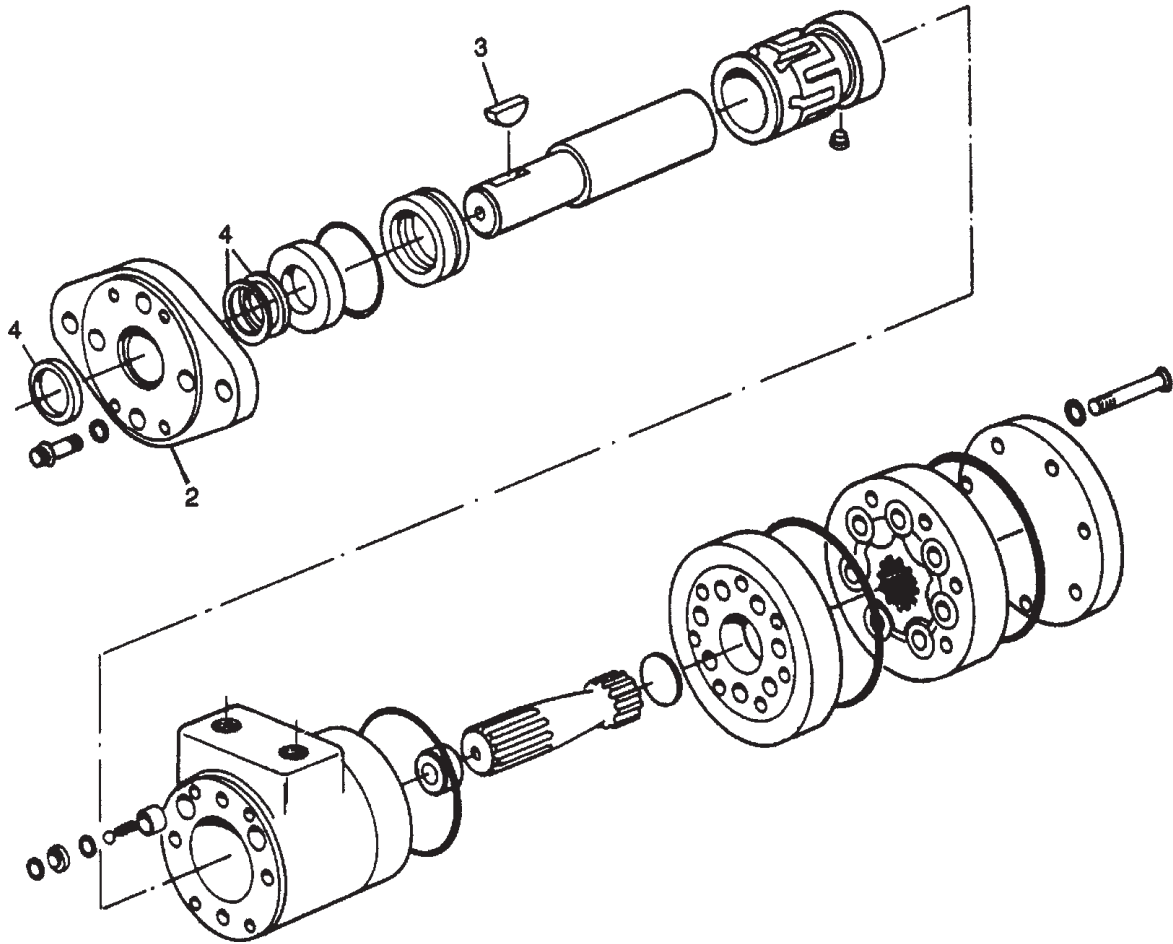


## HYDRAULIC HOSES AND FITTINGS

ITEM	PART	QTY.	PART DESCRIPTION
1	3700537	1	HOSE\HYD\1/2X40\7/8MOR-3/4MOR
2	3700538	1	HOSE\HYD\1/2X38\7/8MOR-3/4FJIC
3	3700604	1	HOSE\HYD\1/2X108\3/4MOR3/4MORS
4	3700604	1	HOSE\HYD\1/2X108\3/4MOR3/4MORS
5	3700617	1	HOSE\HYD\1/2X112\3/4MORSX3/4MOR
6	3700618	1	HOSE\HYD\1/2X118\3/4MOR3/4FJIC90
7	3701508	1	HOSE\HYD\1/2X146\3/4MORS3/4MORS90
8	3701509	1	HOSE\HYD\1/2X170\3/4MORS3/4MORS90
9	3800483	1	FTG\3/4MORX3/4MJICX3/4MJIC\RUN;TEE
10	3800694	4	FTG\3/4FOR\QUICK;CPLR\MALE
11	3900025	1	MOTOR\HYD\17.9\H
12	4000213	1	VALVE\FLW-CRTL\RD-108-16\PRINCE
12a	4000331		VALVE\FLW-CRTL\#8FOR\BRAND
13	4000234	1	VALVE\RELIEF\CROSS\RC13BB\1000&1800PSI
14	4100273	1	CYL\HYD\4-1/2X24\1-3/4\CANADIAN TOOL & DIE
	4100223		KIT\SEAL\CYL\HYD\4-1/2X1-3/4RD
	4100272		ROD\YOKE\CYL\HYD\4-1/2x24\1-3/4\>
14a	4100324	1	CYL\HYD\4-1/2X24\1-3/4\RAM INDUSTRIES
	4100214		KIT\SEAL\CYL\HYD\4-1/2X24\1-3/4" ROD
15	4700777	4	CLMP\HOSE\1/2
16	7501361	2	CAP\YLLW\DUST\HOSE\HYD
16a	7501362	2	CAP\RED\DUST\HOSE\HYD

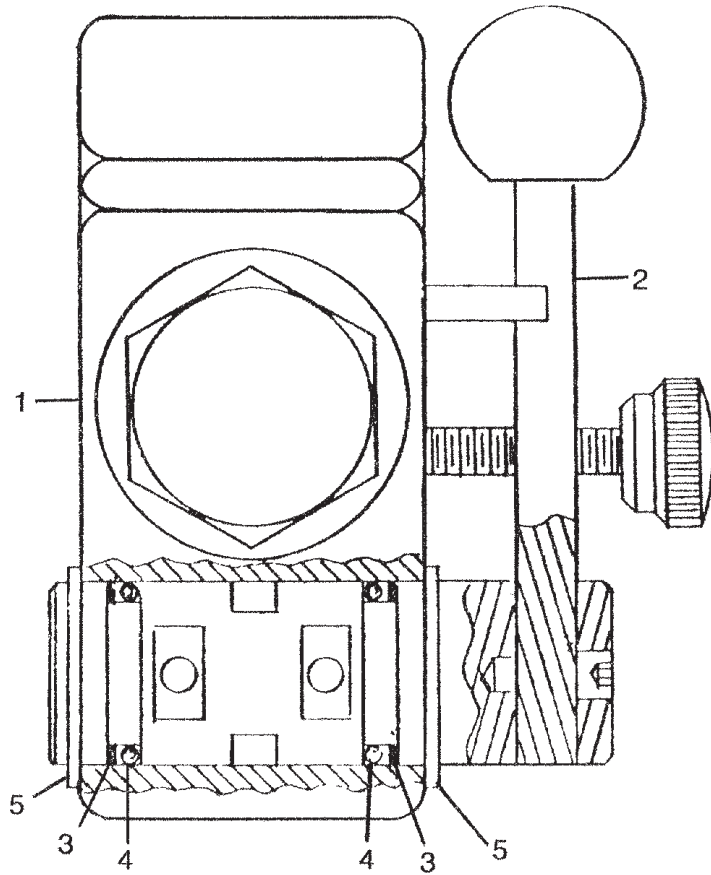
**ORBIT MOTOR**

ITEM	PART NUMBER	QTY	DESCRIPTION
1	3900025		Mtr\Hyd\17.9\HVA;MNT\7/8for o-ring thread
2	3900002	1	Mounting Flange
3	6200011	1	Key, Woodruff
4	7501038	1	Seal Kit
1	3900033		Mtr\Hyd\14.1\7/8FOR
4	7501038	1	Seal Kit

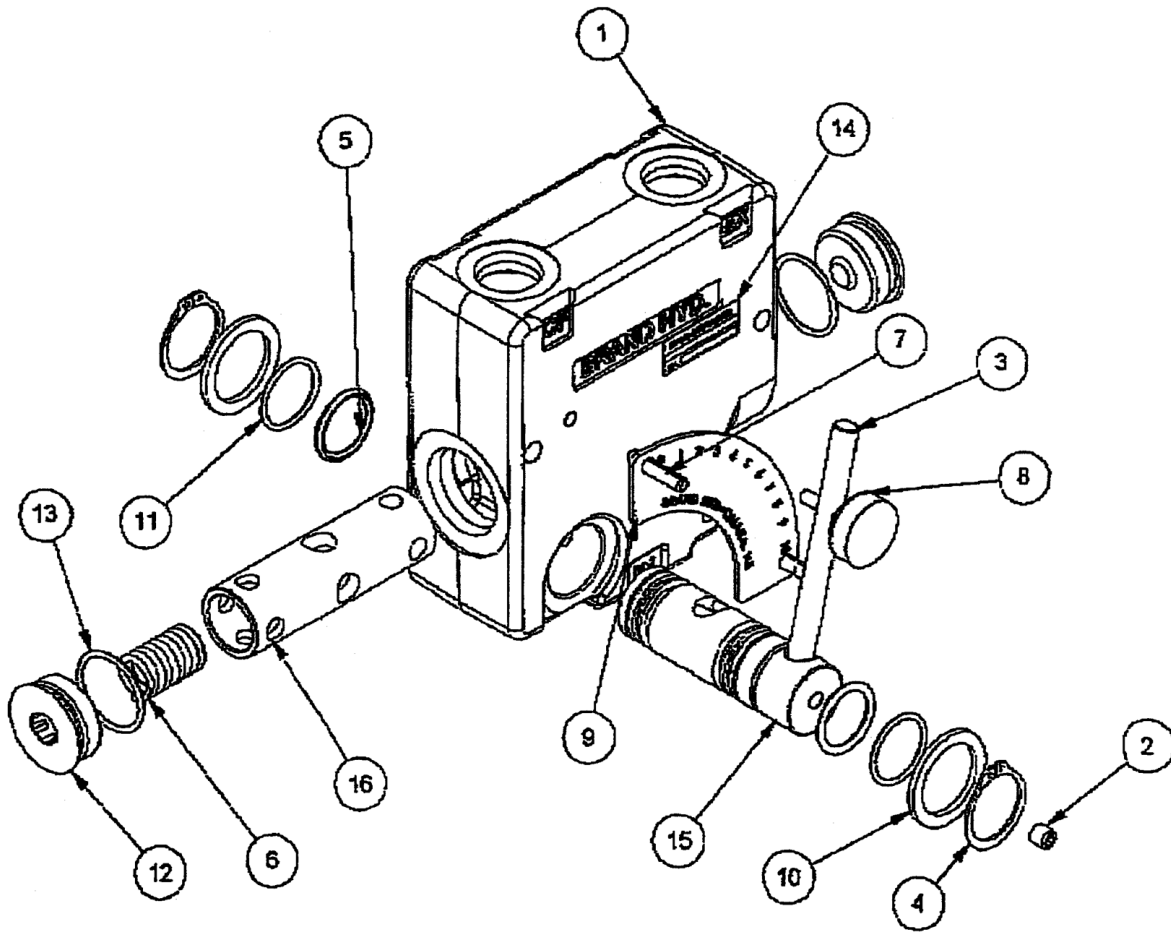


# FLOW CONTROL VALVE

ITEM	PART	QTY.	PART DESCRIPTION
1	4000213	1	Flow Control Valve, o-ring thread
2	4000031	1	Handle Assembly
3 & 4	4000091	1	Seal\Kit\FlowControl
5	4000034	2	Snap Ring



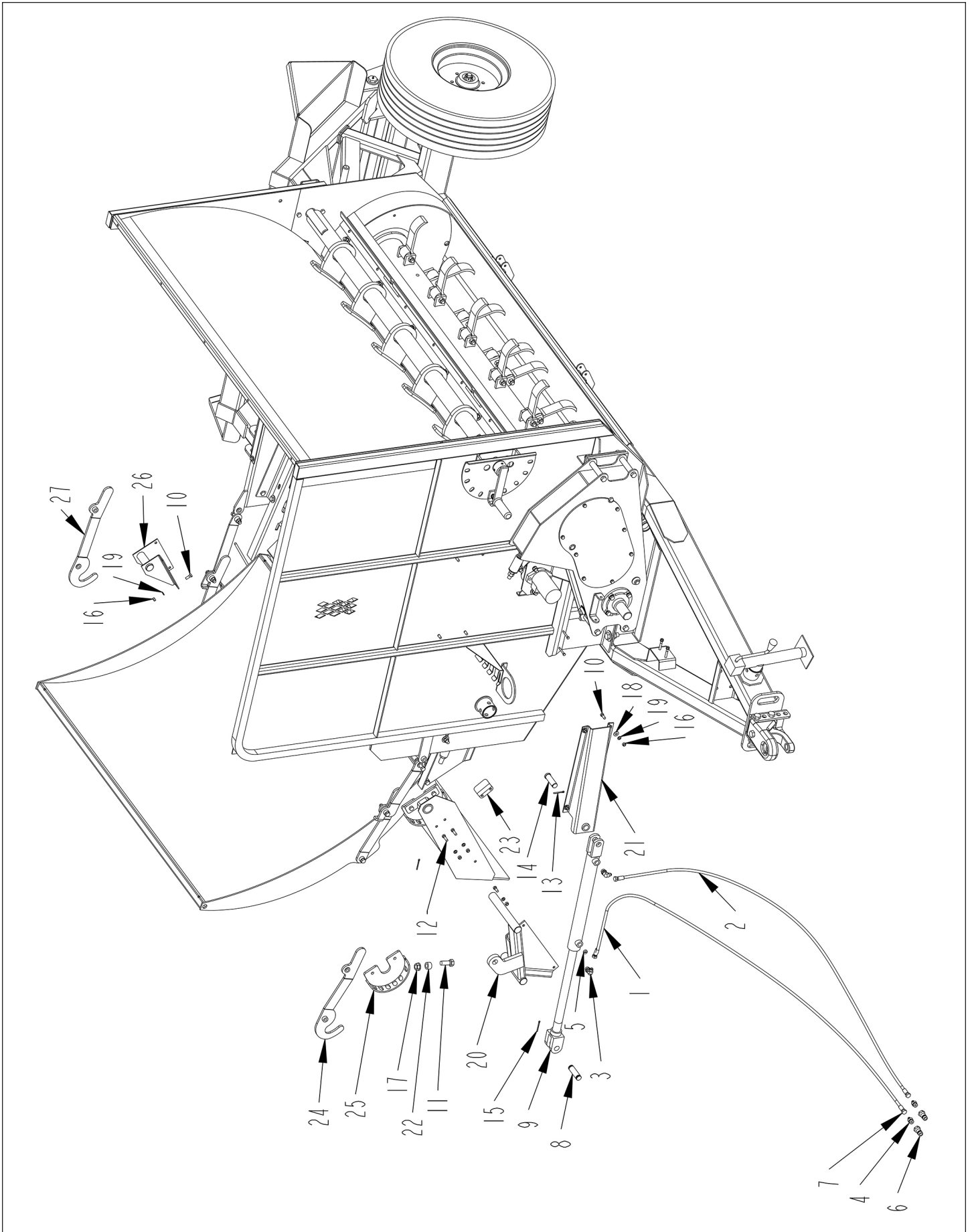
FLOW CONTROL VALVE 4000331



**FLOW CONTROL VALVE 4000331**

<b>ITEM</b>	<b>PART NO.</b>	<b>DESCRIPTION</b>
	4000331	VALVE\FLW-CRTL#8FOR
3 & 8	4000334	HDL\ASSY\WHYD
5,10,11, & 13	4000335	SEAL\KIT\WHYD (INCLUDES 2 EACH OF 5,10,11, & 13)
4	4000336	SNAP RING\WHYD

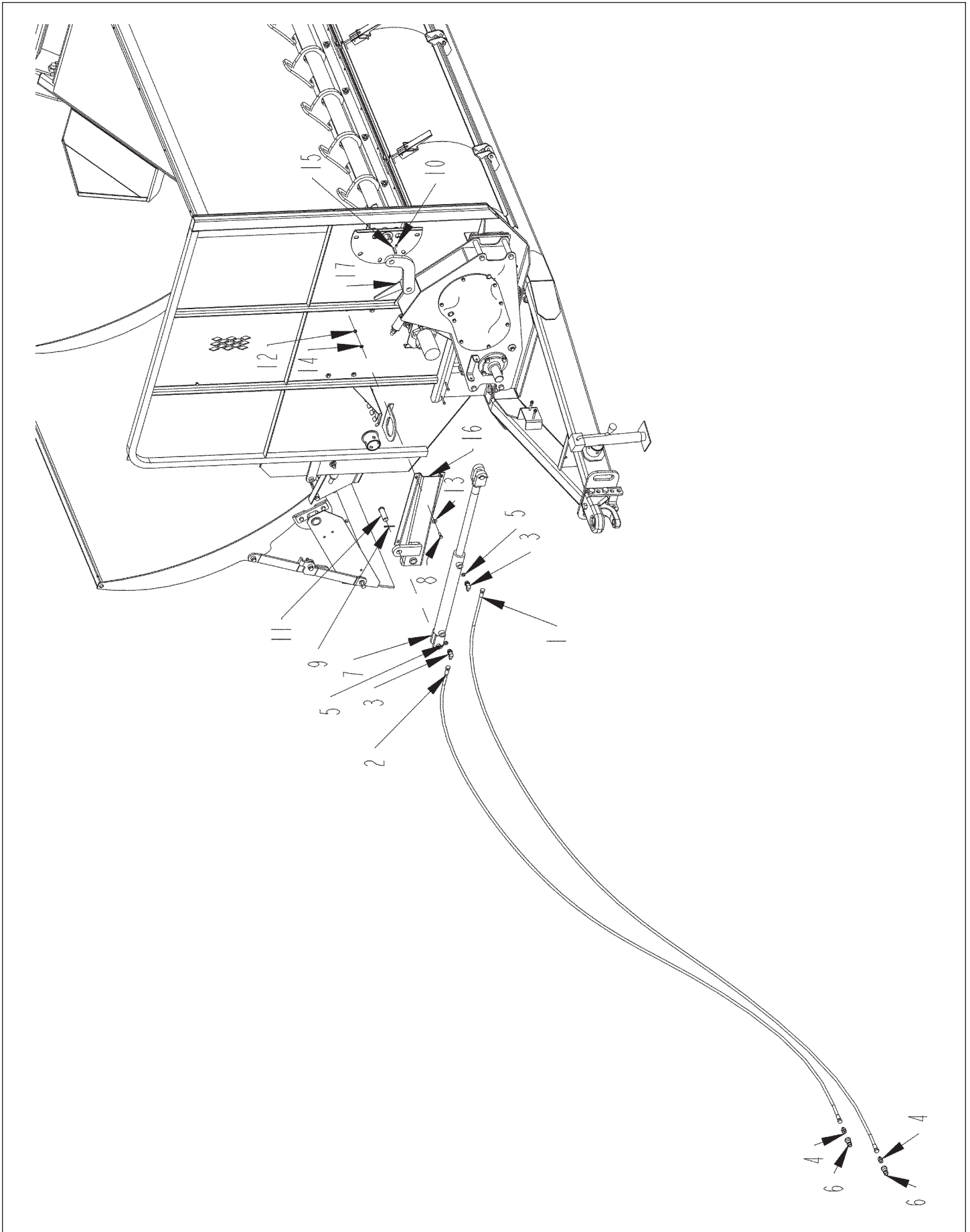
# HYDRAULIC DEFLECTOR (OPTION)



**HYDRAULIC DEFLECTOR (OPTION)**

ITEM	PART	QTY.	PART DESCRIPTION
1	3700609	1	HOSE\HYD\1/4X162\9/16FJXC9/16FJIC
2	3700651	1	HOSE\HYD\1/4X144\9/16FJXC9/16FJIC
3	3800453	2	FTG\3/4MORX9/16MJIC\90
4	3800530	2	FTG\3/4MORX9/16MJIC\ST
5	3800683	1	FTG\3/4MOR\ORFICE\0.0490"
6	3800694	2	FTG\3/4FOR\QUICK;CPLR\MALE
7	3800720	4	FTG\9/16FJICX1/4BARB\SW
8	4100030	1	PIN\CYL\HYD\1X3 1/2\2-HOLE\STD\MNT
8A	4800977		PIN\CLEVIS\1X3-1/4
9	4100229	1	CYL\HYD\2X18\1-1/4ROD-CANADIAN TOOL & DIE
	4100228		SEAL KIT for 4100229
9A	4100326	1	CYL\HYD\2X18\1-1/4ROD-RAM INDUSTRIES
	4100093		SEAL KIT for 4100326
10	4800003	9	BOLT\HEX\3/8X1
11	4800033	1	BOLT\HEX\3/4X2
12	4800098	2	BOLT\HEX\3/8X1-1/4\NC
13	4800530	1	PIN\COT\1/8X1-3/4
14	4800185	1	PIN\CLEVIS\1X3
15	4800203	2	PIN\COT\5/32X2
16	4900002	11	NUT\HEX\3/8\NC
17	4900158	1	NUT\FLG\SERR\3/4\NC
18	5000001	4	WASH\FLAT\3/8
19	5000019	11	WASH\LOCK\3/8
20	8101055	1	MNT\CYL\DFLCTR
21	8101057	1	MNT\CYL\SHRDR\DFLCTR
22	8101096	1	BRKT\STOP\HYD\LOADER
23	8101097	1	BRKT\LATCH\DFLCTR
24	8101098	1	BRKT\STRAP\RACK\HOOK\2650
25	8101146	1	MNT\DFLCTR\W-INDEX
26	8102004	1	MNT\ROD\DFLTR\REAR
27	8102005	1	STRAP\RACK\HOOK\REAR
	<b>8102102</b>		<b>CNTRL\DEFL\HYD\KIT\2660</b>

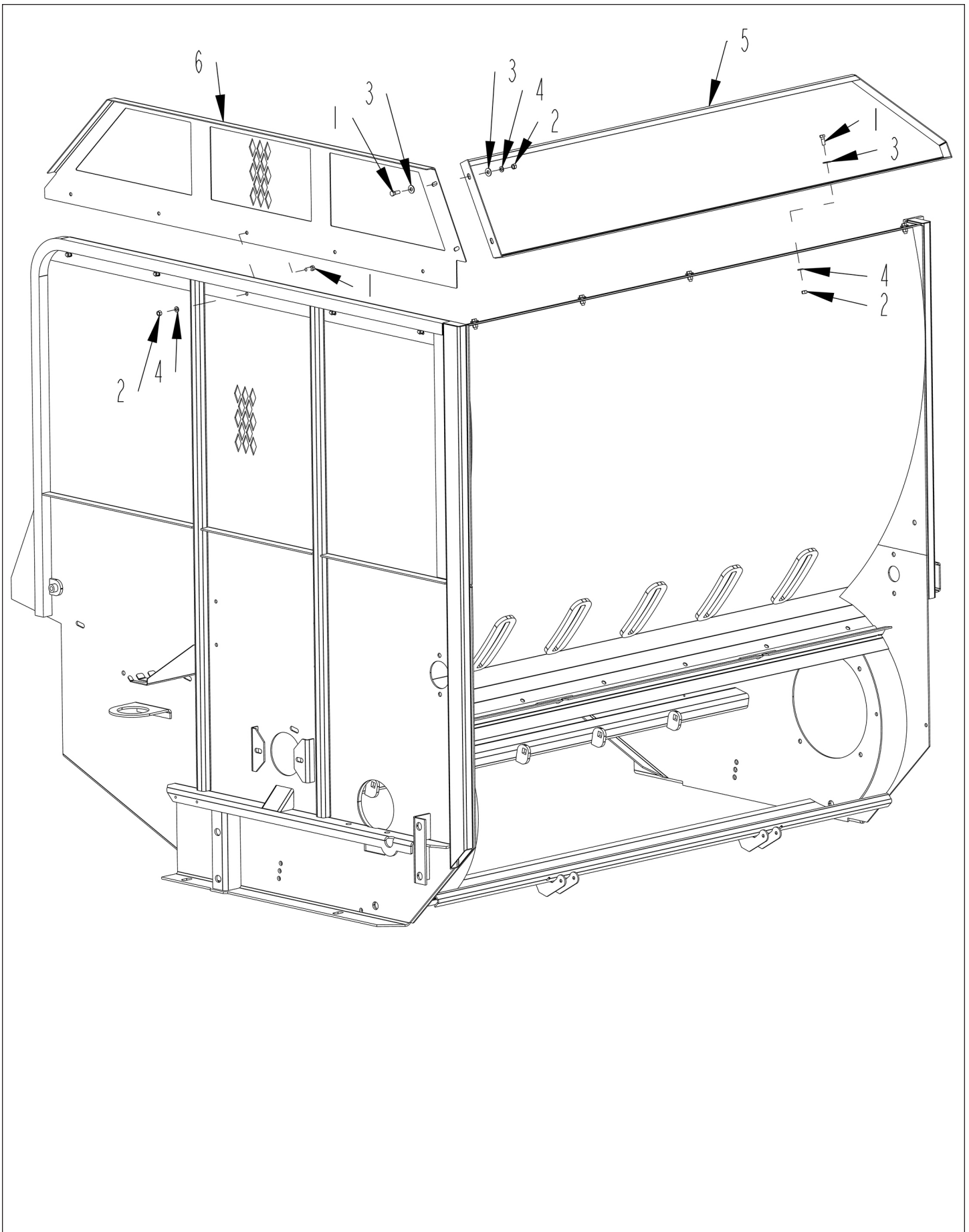
**HYDRAULIC SLUGBAR (OPTION)**



**HYDRAULIC SLUGBAR (OPTION)**

<b>ITEM</b>	<b>PART</b>	<b>QTY.</b>	<b>PART DESCRIPTION</b>
1	3700609	1	HOSE\HYD\1/4X162\9/16FJC9/16FJIC
2	3700651	1	HOSE\HYD\1/4X144\9/16FJIC
3	3800453	2	FTG\3/4MORX9/16MJIC\90
4	3800530	2	FTG\3/4MORX9/16MJIC\ST
5	3800683	2	FTG\3/4MOR\ORFICE\0.0490"
6	3800694	2	FTG\3/4FOR\QUICK;CPLR\MALE
7	4100229 4100228	1	CYL\HYD\2X18\1-1/4ROD-CANADIAN TOOL & DIE SEAL KIT for 4100229
7A	4100326 4100093	1	CYL\HYD\2X18\1-1/4ROD-RAM INDUSTRIES SEAL KIT for 4100326
8	4800003	29	BOLT\HEX\3/8X1
9	4800120	2	PIN\COT\3/16X1-3/4
10	4800143	9	SCR\SET\ALN\3/8X3/8\NC
11	4800185	2	PIN\CLEVIS\1X3
12	4900002	28	NUT\HEX\3/8\NC
13	5000001	28	WASH\FLAT\3/8
14	5000019	36	WASH\LOCK\3/8
15	6200021	1	KEY\SQ\3/8X1-1/2\HARDEND
16	8101779	1	MNT\CYL\SHRDR\SLGBR
17	8101780	1	MNT\CYL\HYD\SLGBR\2650
18	8101781	1	CNTRL\SLGBR\HYD\KIT\2650

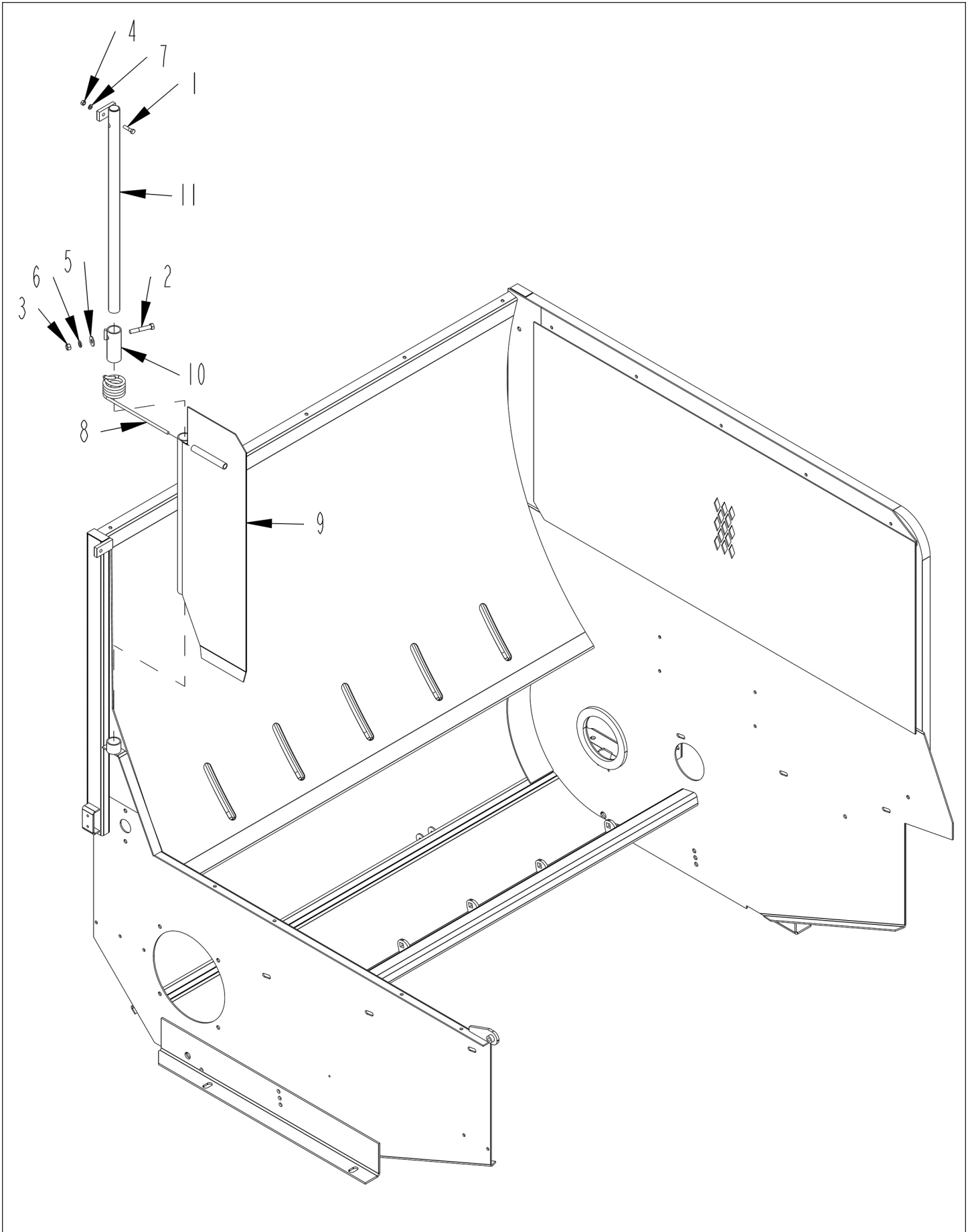
**CONTAINMENT EXTENSIONS (OPTION)**



**CONTAINMENT EXTENSIONS (OPTION)**

<b>ITEM</b>	<b>PART</b>	<b>QTY.</b>	<b>PART DESCRIPTION</b>
1	4800003	12	BOLT\HEX\3/8X1
2	4900002	12	NUT\HEX\3/8\NC
3	5000001	9	WASH\FLAT\3/8
4	5000019	12	WASH\LOCK\3/8
5	8101886	1	EXT\SIDE\SHREDDER
6	8101887	1	SHLD\FR\SHREDDER
	<b>8101889</b>		<b>KIT\CNTNMNT\SHRDR\2660\2665</b>

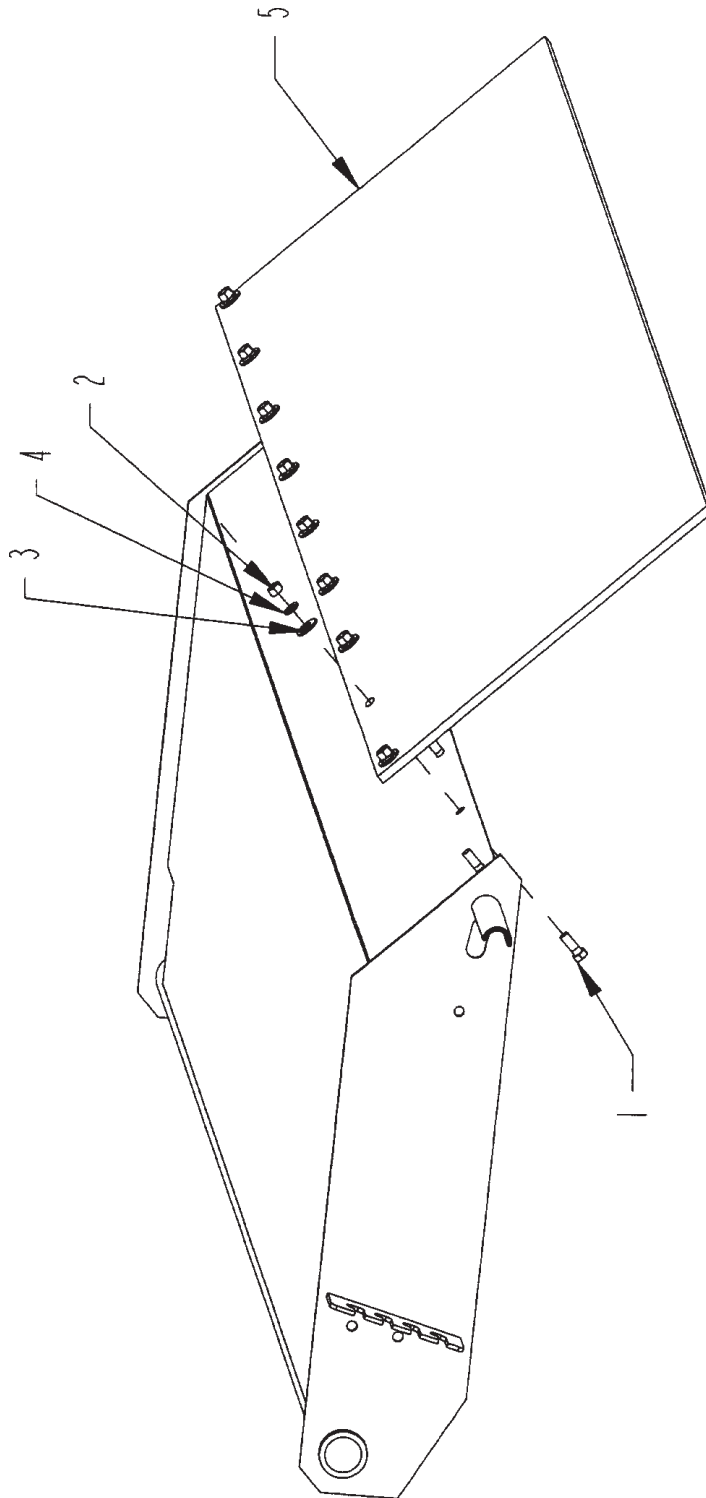
**CONTAINMENT FLAP (OPTION)**



**CONTAINMENT FLAP (OPTION)**

<b>ITEM</b>	<b>PART</b>	<b>QTY.</b>	<b>PART DESCRIPTION</b>
1	4800034	1	BOLT\HEX\3/8X1-1/2
2	4800068	1	BOLT\HEX\1/2X3
3	4900001	1	NUT\HEX\1/2\NC
4	4900002	1	NUT\HEX\3/8\NC
5	5000004	1	WASH\FLAT\1/2
6	5000006	1	WASH\LOCK\1/2
7	5000019	1	WASH\LOCK\3/8
8	6100079	1	SPG\DRITUB
9	8101959	1	FLAP\CON-KIT
10	8101960	1	MNT\SPNG\CON-KIT
11	8101961	1	MNT\FLAP\CON-KIT
	8101962		KIT\FLAP\CON - INCLUDED IN 8101889

**OPTIONAL WIDE DEFLECTOR BELT**

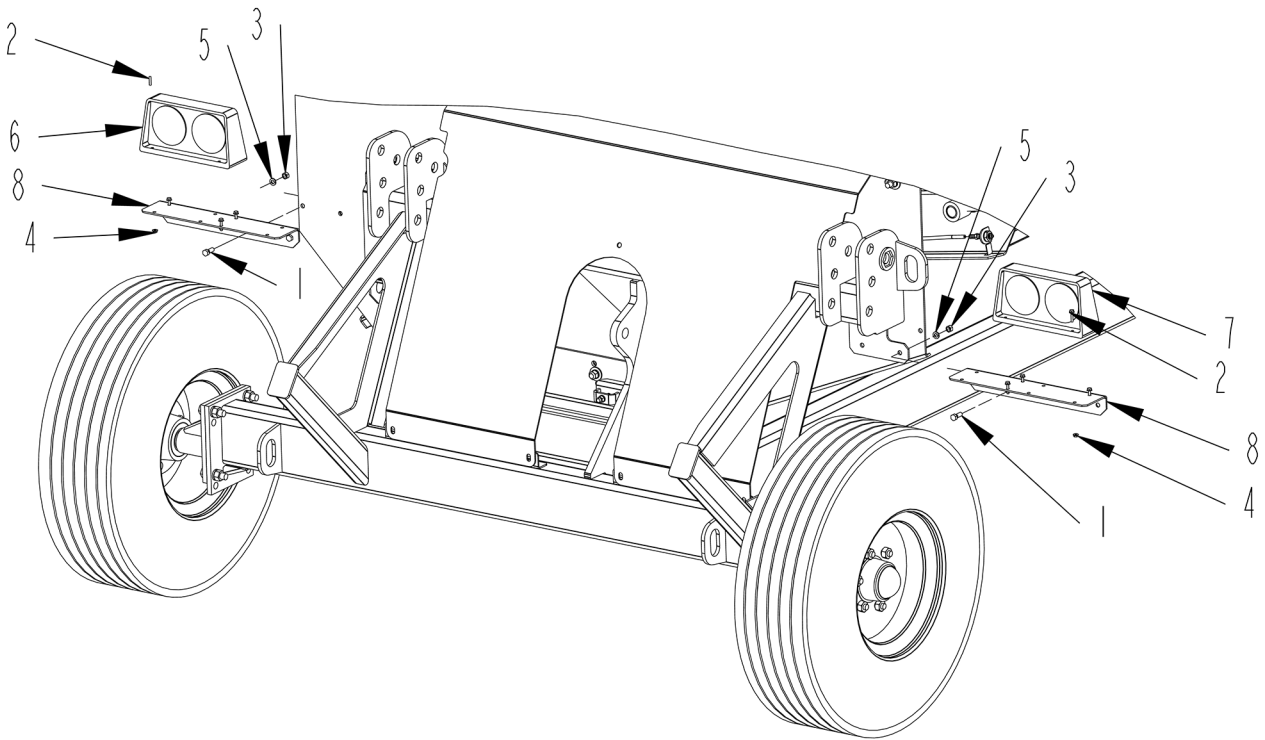
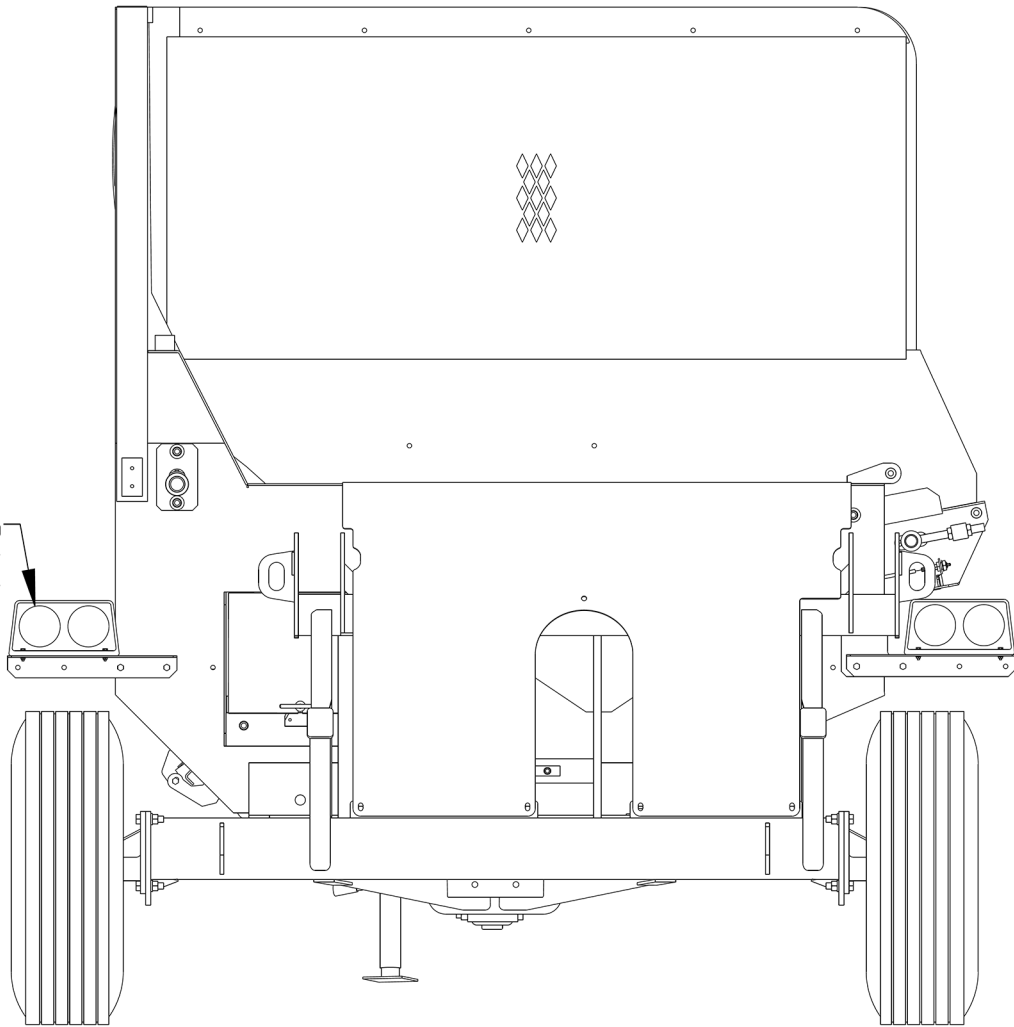


**OPTIONAL WIDE DEFLECTOR BELT**

<b>ITEM</b>	<b>PART</b>	<b>QTY.</b>	<b>PART DESCRIPTION</b>
1	4800003	9	BOLT\HEX\3/8X1
2	4900002	9	NUT\HEX\3/8\NC
3	5000001	9	WASH\FLAT\3/8
4	5000019	9	WASH\LOCK\3/8
5	8100819	1	BELT\DFLCTR\18 x 73-3/4

# TAILLIGHT - STD. MOUNTING

MOUNT AMBER BULB  
TO OUTSIDE



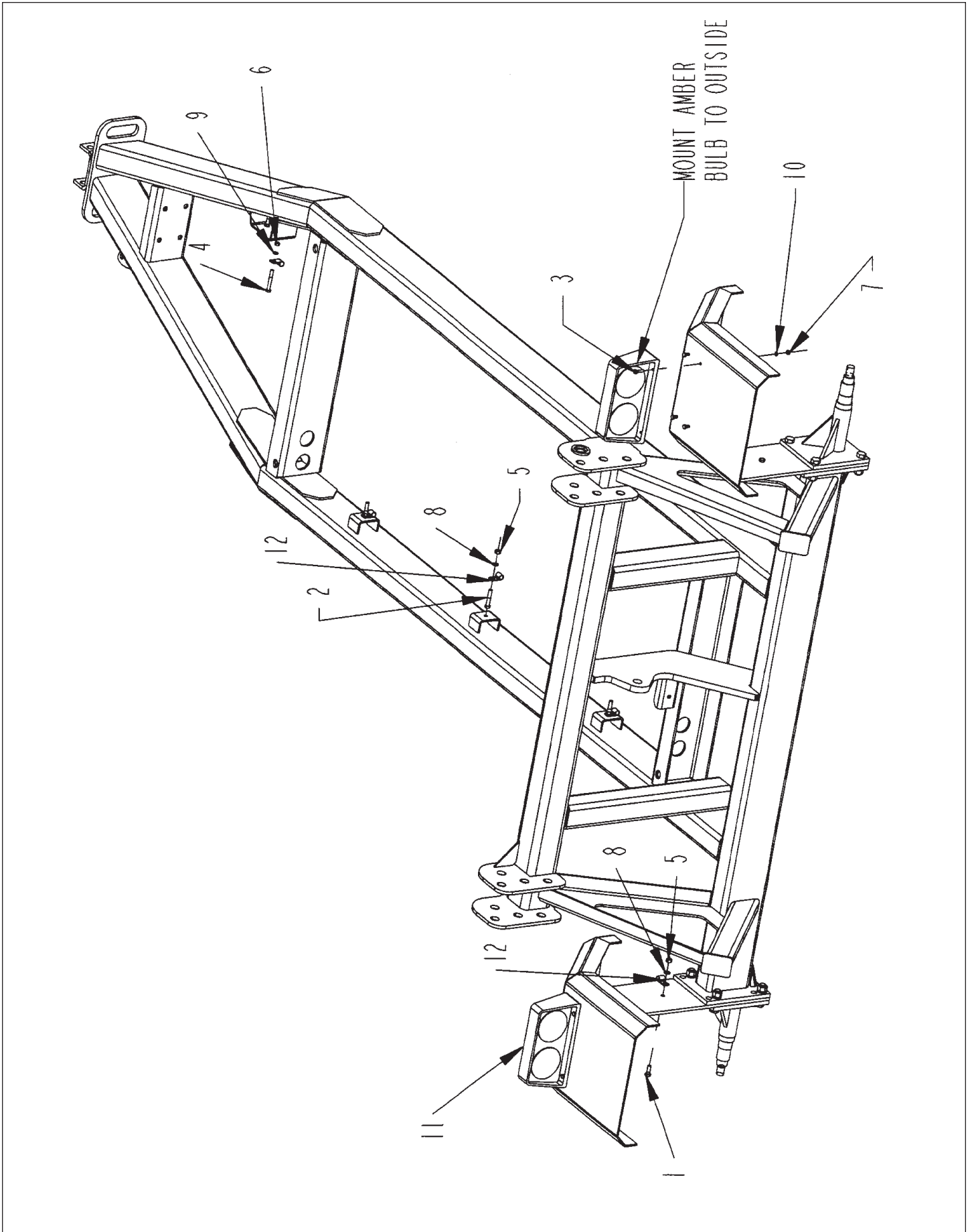
**TAILLIGHT - STD. MOUNTING**

ITEM	PART	QTY.	PART DESCRIPTION
	<b>8100905</b>		<b>TAILIGHT\KIT</b>
1	4800003	4	BOLT\HEX\3/8X1
2	4801321	8	BOLT\FLG\SERR\#10X1\NC
3	4900002	4	NUT\HEX\3/8\NC
4	4900190	8	NUT\FLG\SERR\#10\NC
5	5000019	4	WASH\LOCK\3/8
6	5701058	1	TAILLIGHT\RED;RIGHT\LED\ASSY\4PIN
7	5701059	1	TAILLIGHT\RED;LEFT\LED\ASSY\4PIN
8	8101372	2	BRKT\TAILIGHT\2650
	5700924		HARN\TAIL;LIGHTS\SHREDDR\4PIN
	5701079		KIT\LIGHT\LED\2-LIGHT\4-PIN (includes 5701058, 5701059, 5700924)

**NOT SHOWN**

7501353	SIGN\SMV\PLSTC-BCKNG
7500713	CLAMP\CUSH\HD\1/2

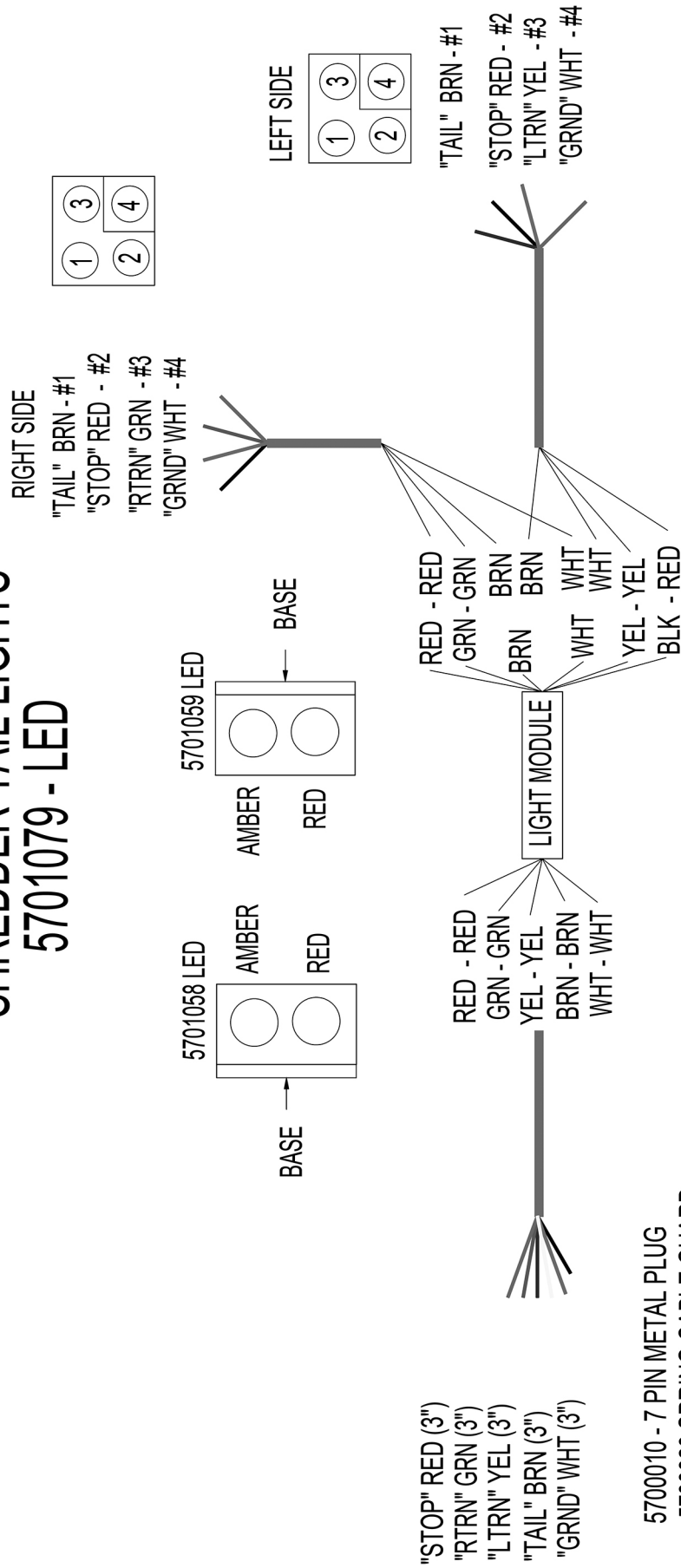
**OPTIONAL TAILLIGHT - FENDER MOUNTING  
(USE WITH HIGHWAY TIRES ONLY)**



**OPTIONAL TAILLIGHT - FENDER MOUNTING  
(USE WITH HIGHWAY TIRES ONLY)**

ITEM	PART	QTY.	PART DESCRIPTION
1	4800003	2	BOLT\HEX\3/8X1
2	4800146	3	BOLT\HEX\3/8X2
3	4800277	8	BOLT\HEX\1/4X1
3A	4801321	8	BOLT\FLG\SERR\#10X1\NC
4	4800570	2	BOLT\HEX\5/16X2-1/2
5	4900002	5	NUT\HEX\3/8\NC
6	4900003	2	NUT\HEX\5/16\NC
7	4900009	8	NUT\HEX\1/4\NC
7A	4900190	8	NUT\FLG\SERR\#10\NC
8	5000019	5	WASH\LOCK\3/8
9	5000022	2	WASH\LOCK\5/16
10	5000024	8	WASH\LOCK\1/4
11	5700925	2	KIT\LIGHT (includes 5700715, 5700716, 5700924)
	5700715	1	TAILLIGHT\RED;RIGHT\ASSY\4PIN
	5700716	1	TAILLIGHT\RED;LEFT\ASSY\4PIN
11LED	5701079	1	KIT\LIGHT\LED\2-LIGHT\4-PIN (includes 5701058, 5701059, 5700924)
	5701058	1	TAILLIGHT\RED;R\LED\ASSY\4PIN
	5701059	1	TAILLIGHT\RED;L\LED\ASSY\4PIN
	5700924	1	HARN\TAIL;LIGHTS\SHREDDR\4PIN
12	7500713	6	CLAMP\CUSH\HD\1/2

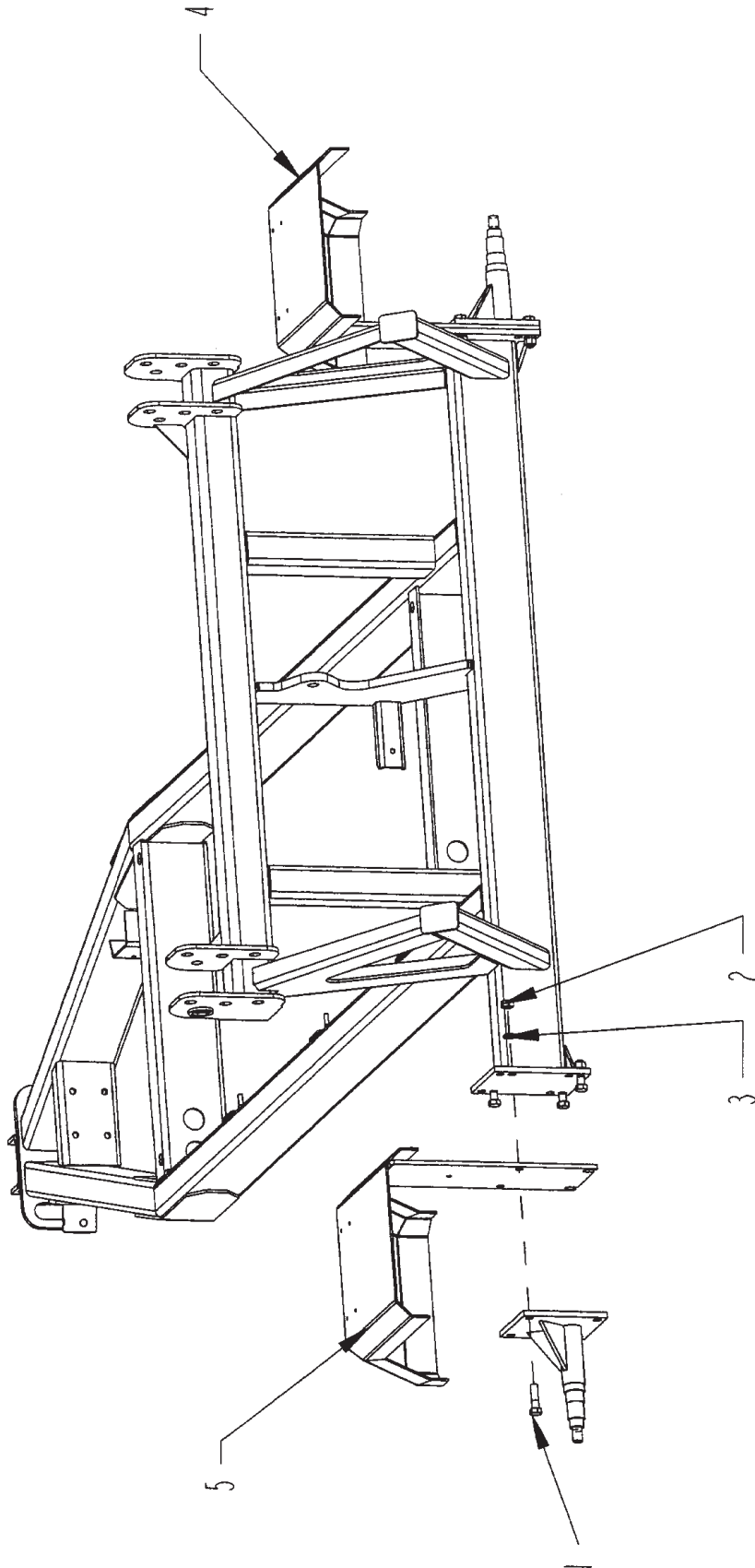
# SHREDDER TAIL LIGHTS 5701079 - LED



- 5700010 - 7 PIN METAL PLUG
- 5700829 SPRING CABLE GUARD
- 5700924 HARNESS



**OPTIONAL FENDER**

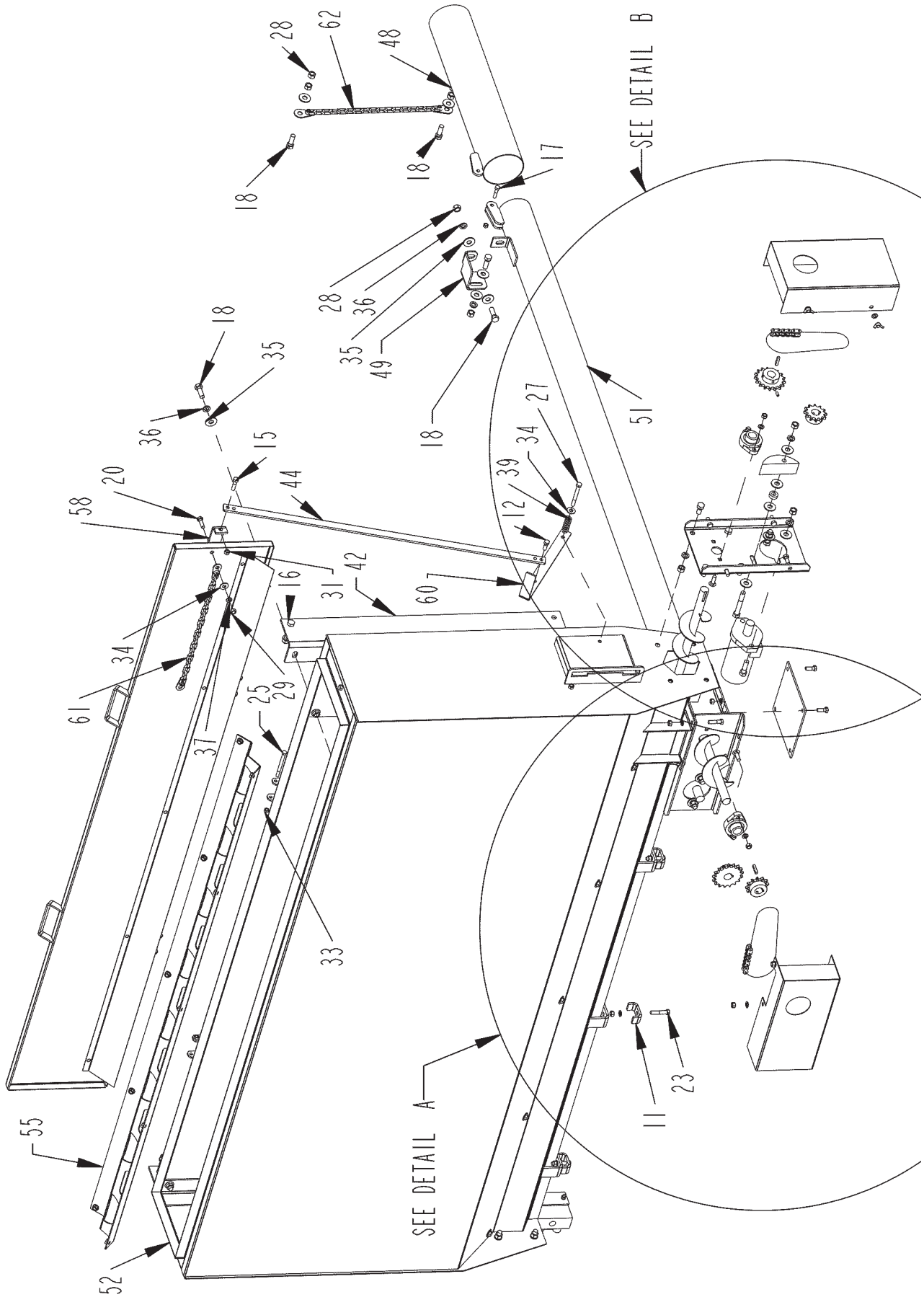


**OPTIONAL FENDER**

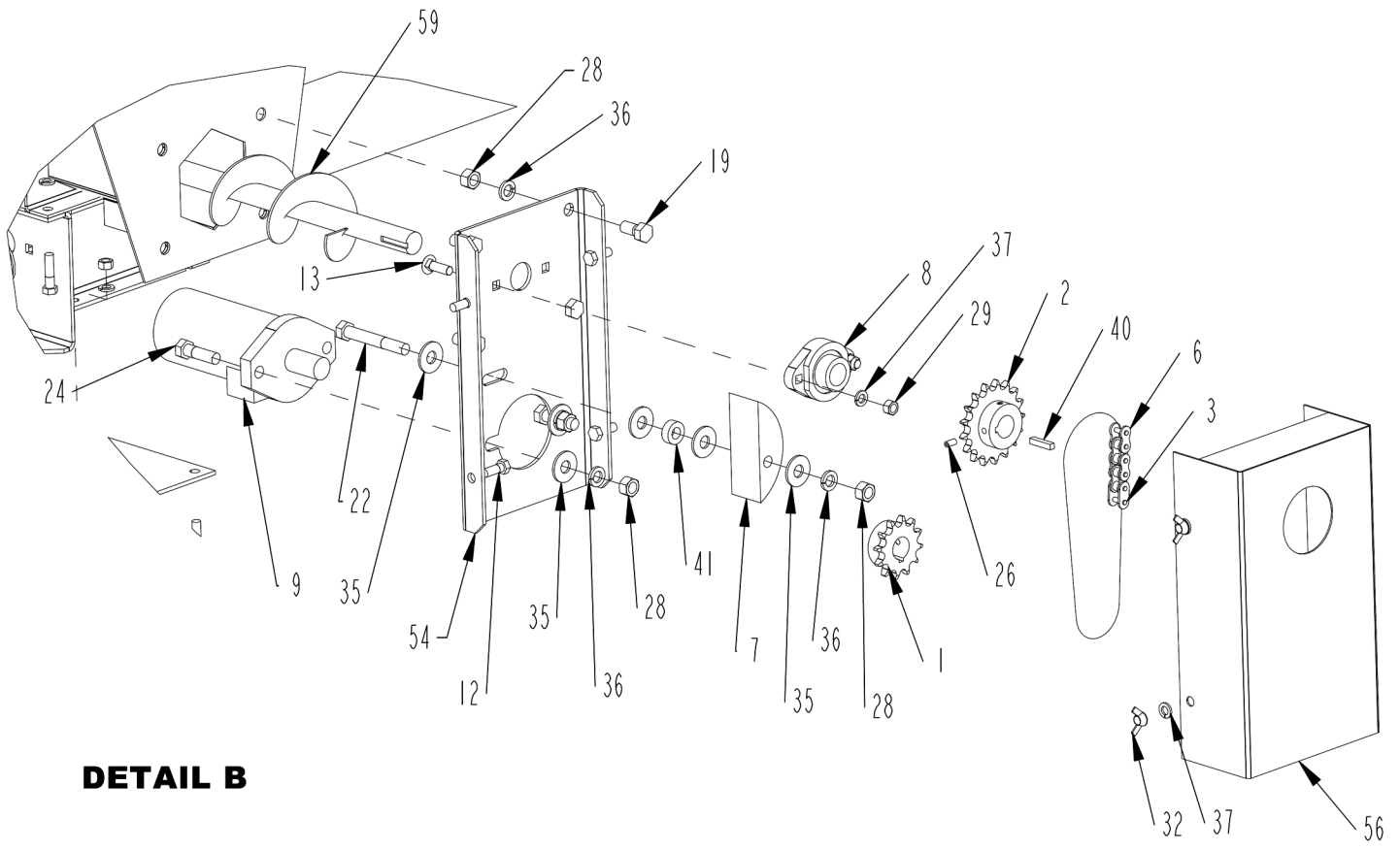
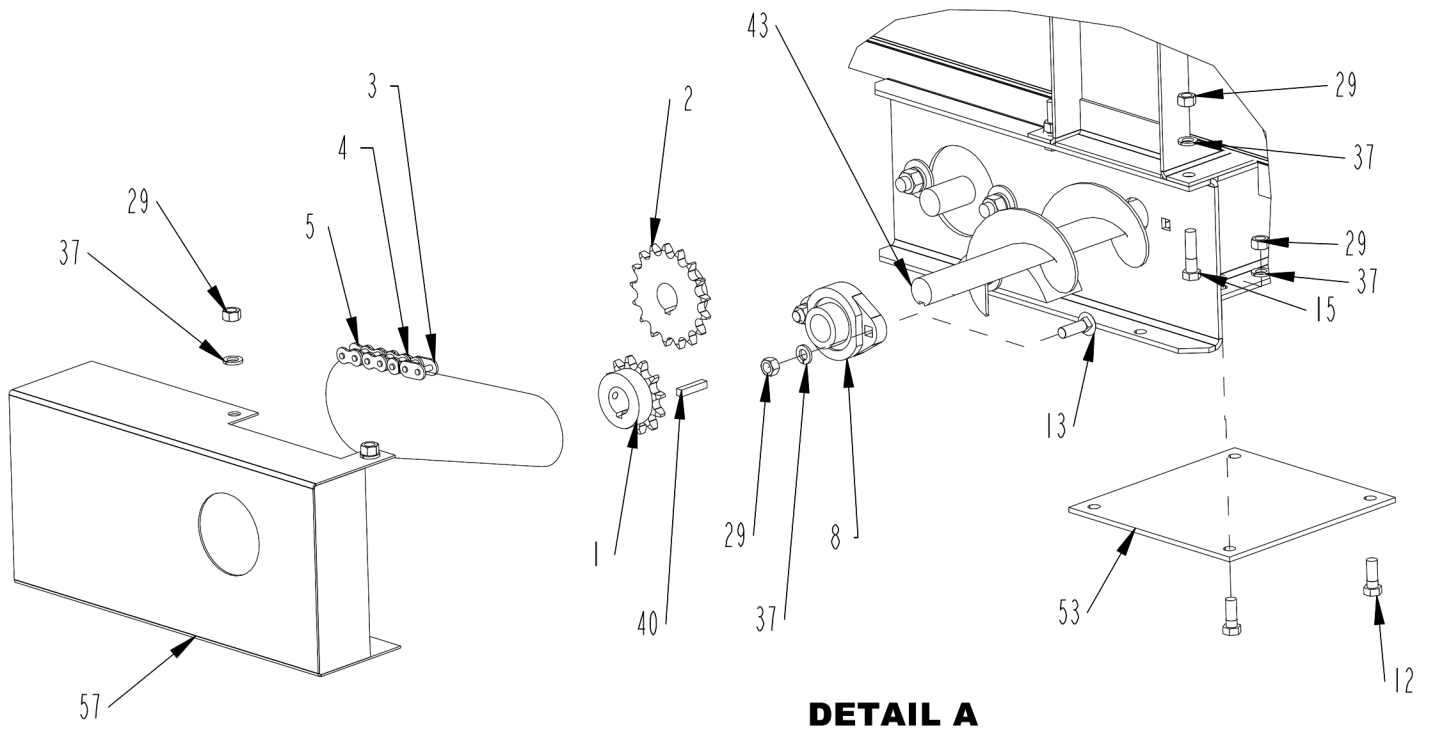
<b>ITEM</b>	<b>PART</b>	<b>QTY.</b>	<b>PART DESCRIPTION</b>
1	4800350	8	BOLT\HEX\5/8X2-1/4
2	4900005	8	NUT\HEX\5/8\NC
3	5000003	8	WASH\LOCK\5/8
4	8100827	1	FNDR\2620\RT
5	8100828	1	FNDR\2620\LT

**Note - use with 2600832 Highway Tires only.**

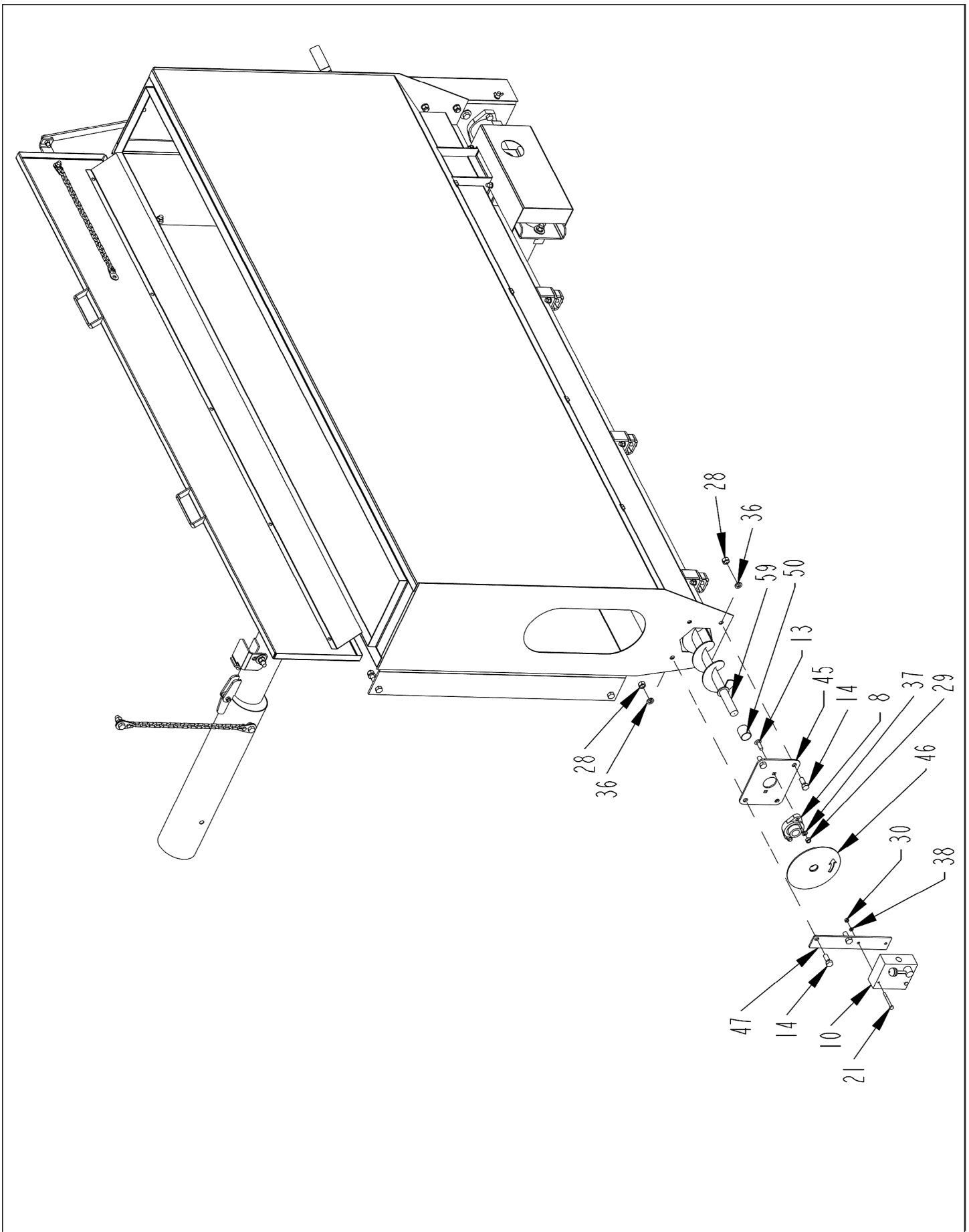
**GRAIN TANK (OPTION) ASSEMBLY (O-RING)**



**GRAIN TANK (OPTION) ASSEMBLY (O-RING) - DETAILS A&B**



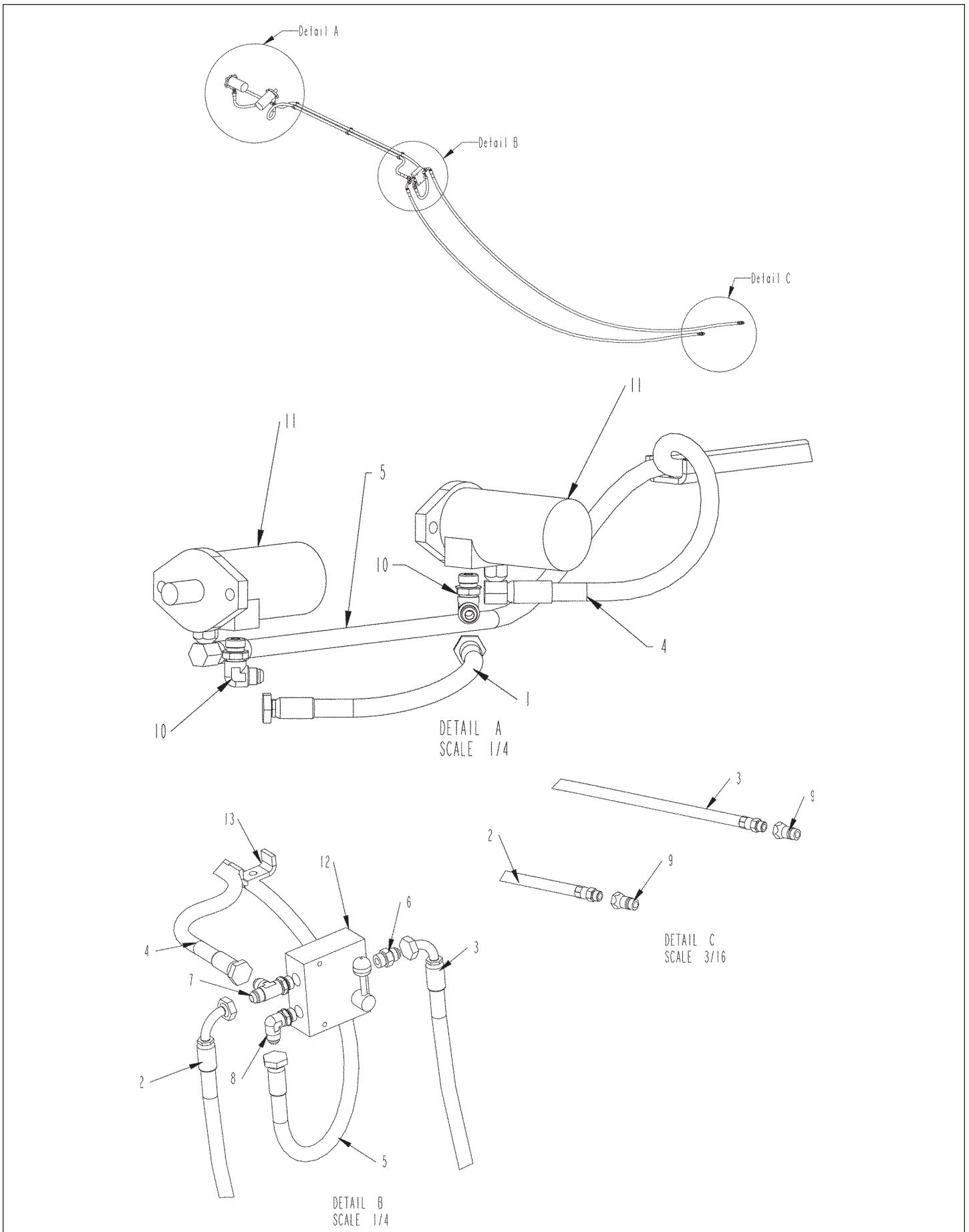
**GRAIN TANK (OPTION) ASSEMBLY (O-RING) - TANK DETAILS**



**GRAIN TANK (OPTION) ASSEMBLY (O-RING) - PARTS LIST**

ITEM	PART	QTY.	PART DESCRIPTION
1	1000055	2	SPKT\50\B\12\1\1/4KW
2	1000060	2	SPRKT\50\B\17\1\1/4KW\SOFT
3	1100059	2	CHAIN\50\CL
4	1100060	1	CHAIN\50\OL
5	1100276	1	CHAIN\50\41
6	1100277	1	CHAIN\50\37
7	2000016	2	BLK\WOOD\IDLER
8	2000310	3	BRG\FLG\CAST\1\2BOLT
9	3900033	2	MTR\HYD\101-1038\14.1CI\7/8FOR
10	4000213	1	VALVE\CONTROL\FLOW\3/4FOR
11	4700777	3	CLMP\HOSE\1/2
12	4800003	21	BOLT\HEX\3/8X1
13	4800012	6	BOLT\CRG\3/8X1-1/4\NC
14	4800018	4	BOLT\HEX\1/2X1-1/4
15	4800034	3	BOLT\HEX\3/8X1-1/2
16	4800068	4	BOLT\HEX\1/2X3
17	4800081	1	BOLT\HEX\5/16X1-1/2
18	4800082	8	BOLT\HEX\1/2X1-1/2
19	4800085	4	BOLT\HEX\1/2X1
20	4800098	2	BOLT\HEX\3/8X1-1/4\NC
21	4800101	2	BOLT\HEX\1/4X2-1/2
22	4800135	2	BOLT\HEX\1/2X3-1/2
23	4800146	3	BOLT\HEX\3/8X2
24	4800178	4	BOLT\HEX\1/2X1-3/4
25	4800198	2	BOLT\HEX\5/16X3-3/4
26	4800290	8	SCR\SET\VALN\1/4X1/2\NC
27	4800515	1	BOLT\HEX\3/8X3-1/4\NC
28	4900001	24	NUT\HEX\1/2\NC
29	4900002	21	NUT\HEX\3/8\NC
30	4900009	2	NUT\HEX\1/4\NC
31	4900023	3	NUT\PLCK\3/8\NC
32	4900032	4	NUT\WING\3/8\NC
33	4900099	3	NUT\PLCK\5/16\GR8\NC
34	5000001	13	WASH\FLAT\3/8
35	5000004	22	WASH\FLAT\1/2
36	5000006	24	WASH\LOCK\1/2
37	5000019	25	WASH\LOCK\3/8
38	5000024	2	WASH\LOCK\1/4
39	6100028	1	2-1/4 COMP SPR.125 X .725
40	6200014	2	KEY\SQ\1/4X1-1/4
41	8100804	2	MNT\BSHMTR\HYD
42	8100834	2	MNT\HPPR\GRAIN
43	8100842	1	AUG\REAR\ASSY
44	8100868	1	RD\CONNECTING\LID\HPPR
45	8100898	1	PLT\MNT\BRNG\AUG
46	8100899	1	BRKT\INDICATOR\AUG
47	8100906	1	PLT\MNT\VALVE\FLOW
48	8101166	1	TUBE\EXT\AUG\HPPR\GRAIN
49	8101170	1	BRKT\SUPPORT\AUGER\GRAIN TANK
50	8101194	1	HPPR\GRAIN\SPCR
51	8101517	1	ASSY\TRANS\AUGER
52	8101518	1	TANK\GRAIN\2650
53	8101520	1	PLT\AUG\CLEAN-OUT
54	8101521	1	PLT\AUG\HPPR
55	8101522	1	BFFL\GRN\HPPR
56	8101523	1	SHLD\REAR\HPPR\GRAIN
57	8101524	1	SHLD\REAR\HPPR\GRAIN
58	8101704	1	HPPR\COVER\90-3/8"
59	8101719	1	ASSY\SHFT\AUG\HPPR
60	8101722	1	BRKT\HANDLE\LID\HPPR
61	8101906	1	ASSY\CHAIN\3/8" BOLT
62	8101910	1	ASSY\CHAIN\1/2" BOLT
<b>8101519</b>			<b>TANK\GRAIN\ASSY\COMPL\2650</b>
<b>DECALS</b>			
6500020			DECAL\LOGO\HYBSTR\SNBRS\3
6500302			DECAL\LOGO\STRIP\RD&BLK

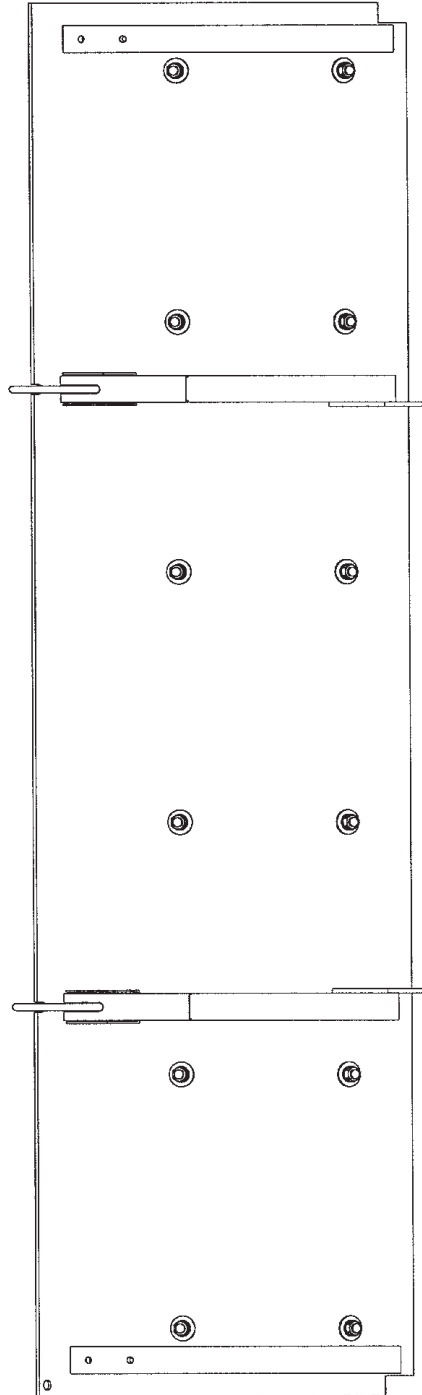
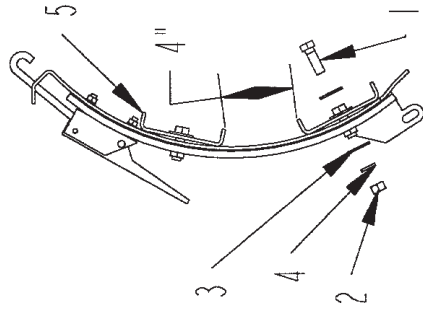
# GRAIN TANK (OPTION) HYDRAULICS DETAILS (O-RING)



**GRAIN TANK (OPTION) HYDRAULICS DETAILS (O-RING)**

<b>ITEM</b>	<b>PART</b>	<b>QTY.</b>	<b>PART DESCRIPTION</b>
1	3700823	1	HOSE\HYD\1/2X17\3/4FJICX3/4FJIC
2	3700824	1	HOSE\HYD\1/2X140\3/4MORX3/4FJIC90
3	3700825	1	HOSE\HYD\1/2X148\3/4MORX3/4FJIC90
4	3700826	1	HOSE\HYD\1/2X82\7/8MOR90X3/4FJIC
5	3700827	1	HOSE\HYD\1/2X100\7/8MOR90X3/4FJIC
6	3800477	1	FTG\3/4MORX3/4MJIC\ST
7	3800483	1	FTG\3/4MORX3/4MJICX3/4MJIC\RUN;TEE
8	3800537	1	FTG\3/4MORX3/4MJIC\90
9	3800694	2	FTG\3/4FOR\QUICK;CPLR\MALE
10	3800696	2	FTG\7/8MORX3/4MJIC\90
11	3900033	2	MTR\HYD\101-1038\14.1CI\7/8FOR
12	4000213	1	VALVE\CONTROL\FLOW\3/4FOR
13	4700777	3	CLMP\HOSE\1/2

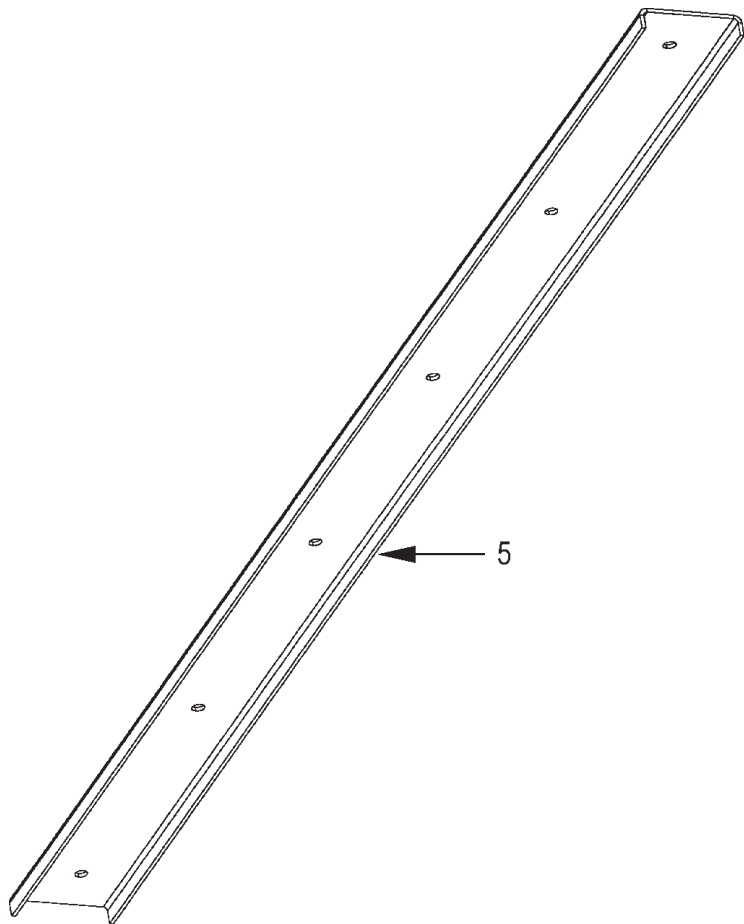
**2660 STRIPPER BAR (OPTION) INSTALLATION**  
**2665 STANDARD STRIPPER BAR INSTALLATION**



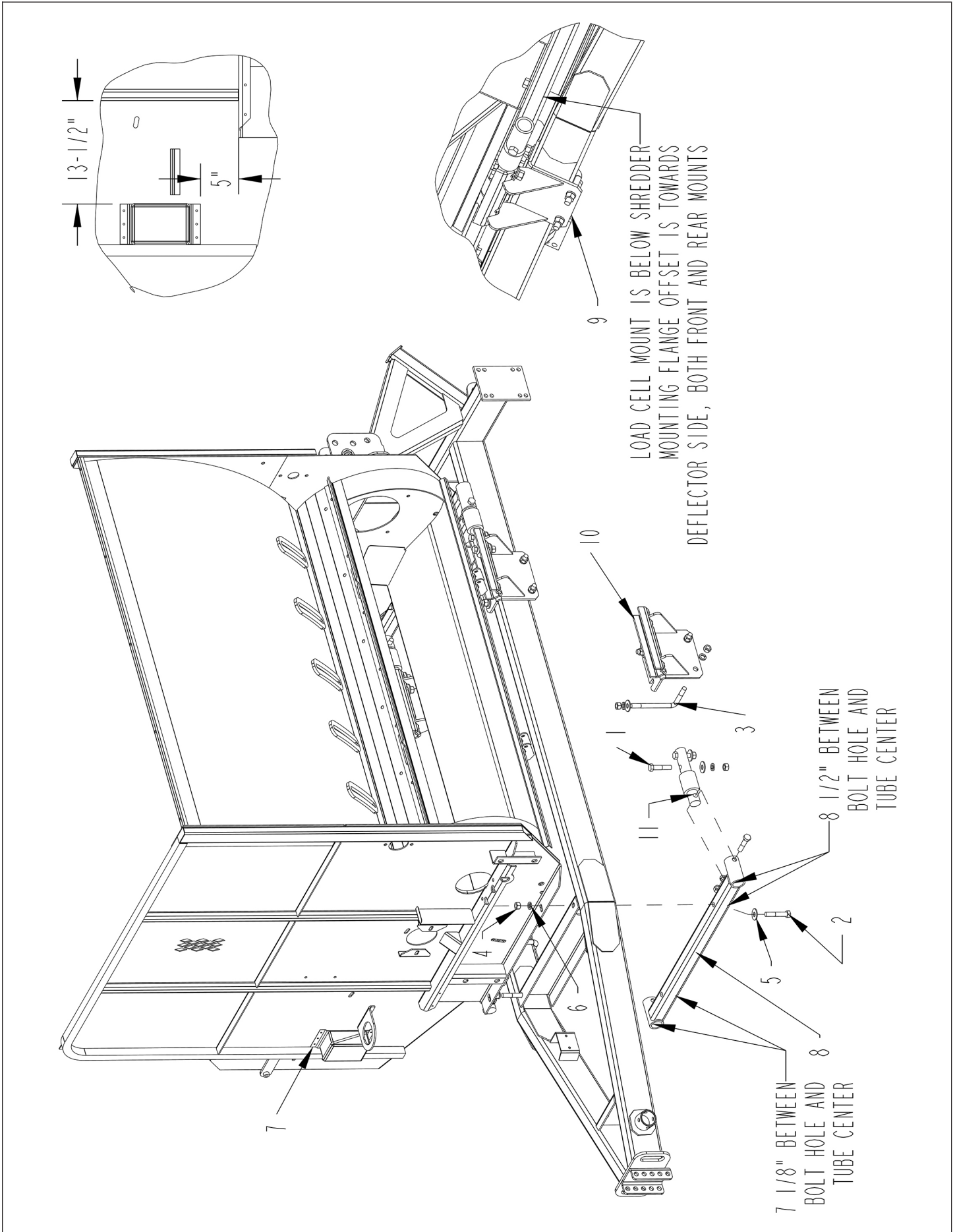
1. POSITION BARS AS SHOWN
2. CLAMP IN PLACE
3. DRILL (6) 9/16 HOLES PER BAR  
USING THE BAR AS A GUIDE.
4. ATTACH AS SHOWN USING LISTED HARDWARE

**2660 STRIPPER BAR (OPTION) INSTALLATION**  
**2665 STANDARD STRIPPER BAR INSTALLATION**

ITEM	PART	QTY.	PART DESCRIPTION
	8100973		CHNNL\STRPPR\KIT
1	4800018	6	BOLT\HEX\1/2X1-1/4
2	4900001	6	NUT\HEX\1/2\NC
3	5000004	12	WASH\FLAT\1/2
4	5000006	6	WASH\LOCK\1/2
5	8100793		CHNNL\STRIPPER\SHREADER\75 - STD (PAGE 48-49)
5A	8101511	1	CHNNL\STRIPPER\SHREADER\69 - OPTION (TO BE BOLTED TO DOOR AS NEEDED)



**WEIGH SCALE - LOAD CELL (OPTION)**



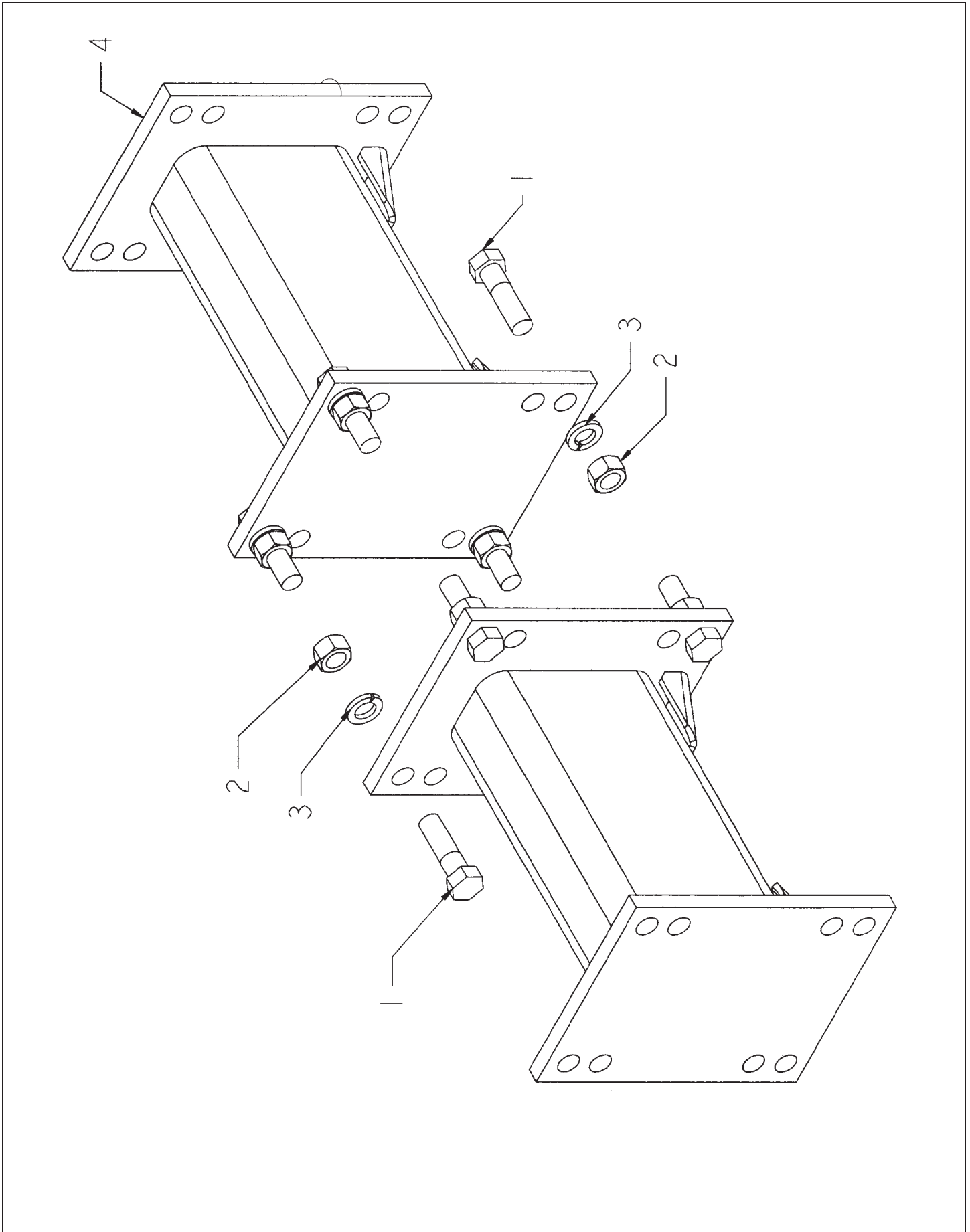
**WEIGH SCALE - LOAD CELL (OPTION)**

<b>ITEM</b>	<b>PART</b>	<b>QTY.</b>	<b>PART DESCRIPTION</b>
1	4800011	12	BOLT\HEX\3/4X3-1/2
2	4800063	4	BOLT\HEX\3/4X4
3	4800200	8	BOLT\L\3/4X5-1/4X8-1/4
4	4900004	32	NUT\HEX\3/4\NC
5	5000005	20	WASH\FLAT\3/4
6	5000012	32	WASH\LOCK\3/4
7	7500978	1	J-BOX\ASSY\15'\SCALE
8	8100883	2	MNT\LOADCELL\SHREADER
9	8101034	2	MNT\RIGHT\LOADCELL\2640
10	8101035	2	MNT\LEFT\LOADCELL\2640
11	7500939	4	LOAD\CELL\SCALE
	7500841	1	SCALE\LOAD;CELL PACKAGE

**INCLUDES**

7500939	4	LOAD\CELL\SCALE
7500978	1	J-BOX\ASSY\INC.;15'CABLE\SCALE
7500979	1	CABLE\EXT\10'\J-BOX;TO;SCALE
7501534	1	INDICATOR\2500\STD
7501211	1	POWER\CORD\10'\4-WIRE
7501212		CBL\15\J-BOX\ for 7500978
7501555		KIT\CONN\LOAD;CELL 4 pin connector kit for 7501212 & 7500979

**AXLE EXTENSIONS (OPTION)**



**AXLE EXTENSIONS (OPTION)**

<b>ITEM</b>	<b>PART</b>	<b>QTY.</b>	<b>PART DESCRIPTION</b>
1	4800350	8	BOLT\HEX\5/8X2-1/4
2	4900005	8	NUT\HEX\5/8\NC
3	5000003	8	WASH\LOCK\5/8
4	8101267	2	AXLE\EXTENSION\12"
5	8101276	1	EXTENSION\AXLEKIT



**DECALS**

<b>ITEM</b>	<b>PART</b>	<b>QTY.</b>	<b>PART DESCRIPTION</b>
1	6500034	2	DECAL\DNGR\FLYG;HAY\RACK
2	6500035	1	DECAL\DNGR\ROTATNG;FLAILS
3	6500040	1	DECAL\WARN\SHIELD\PROT
4	6500041	1	DECAL\WARN\PROTECTION
5	6500043	1	DECAL\WARN\NO;RIDERS
6	6500085	1	DECAL\DNGR\ROTATNG;DR-LNE
7	6500304	1	DECAL\LOGO\HYBSTR\1-3/4W\SUNBURST
8	6500322	1	DECAL\CAUT\ADJ_DRAWBAR\16"
9	6500356	1	DECAL\INDEX\SLUGBAR
10	6500361	2	DECAL\PIN\LOADER\2650
11	6500362	1	DECAL\INFO\BALE ROTATION
12	6500417	5	DECAL\GREASE\10 HRS
13	6500434	5	DECAL\2X9\RED\REFCT
14	6500435	3	DECAL\2X9\AMBER\REFCT
15	6500482	2	DECAL\LOGO\2660W\STRIPE
16	6500490	1	DECAL\WARN\NO STEP
17	6500493	2	DECAL\LOGO\2665W\STRIPE
17a	6500527	2	DECAL\LOGO\SHORTCUT
18	6500546	1	DECAL\BOLTS\FLAIL\156 FT-LBS
	<b>6500481</b>		<b>DECAL\KIT\2660</b>
	<b>6500492</b>		<b>DECAL\KIT\2665</b>

**NOT SHOWN**

7500077	PAIN\YELLOW\SPRAY\12OZ
7500092	PAIN\YELLOW\QUART
7500091	PAIN\YELLOW\GALLON
7500078	PAIN\RED\SPRAY\12OZ
7500105	PAIN\RED\QUART
7500104	PAIN\RED\GALLON

**DECAL LOCATIONS**



**DECAL LOCATIONS**







Please fill out the delivery report on the following pages. The white copy is to be returned to:

**DuraTech Industries International Inc.**  
**P.O. Box 1940**  
**Jamestown, ND**  
**58402-1940**

The yellow copy is the dealer copy; the pink copy is to be retained by the customer.