

Operating Instructions and Parts Reference

# H-1130™

## PTO Driven Tub Grinder

Includes Stationary Electrical Supplement

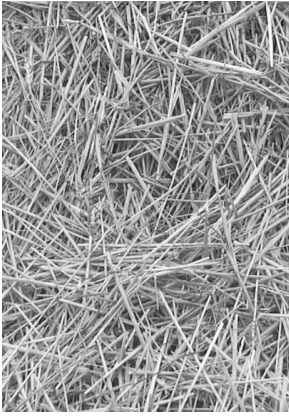


PRODUCT INFORMATION

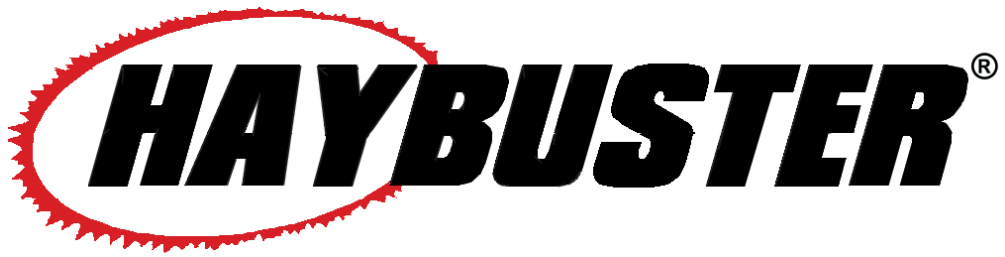
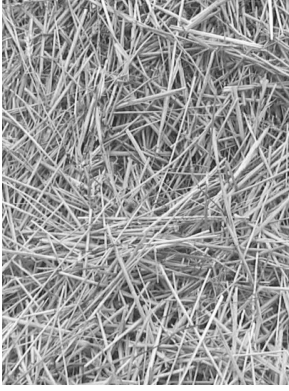


0500140 • NOVEMBER 2018

DURATECH INDUSTRIES INTERNATIONAL INC.  
PO Box 1940, JAMESTOWN, ND 58402-1940  
TEL: (701) 252-4601 • FAX: (701) 252-0502  
WWW.DURATECHINDUSTRIES.NET • WWW.HAYBUSTER.COM



**HAYBUSTER<sup>®</sup>**  
*A Tradition of Innovation Since 1966*



# H-1130<sup>TM</sup>



## PTO Driven Tub Grinder

Includes Stationary Electrical Supplement

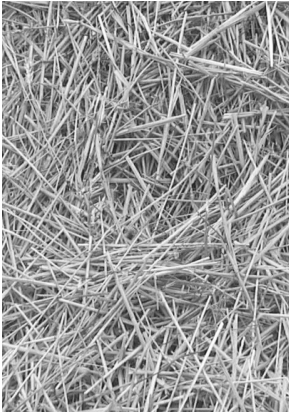
## Operating Instructions and Parts Reference

DuraTech Industries International Inc. (DuraTech Industries) has made every effort to assure that this manual completely and accurately describes the operation and maintenance of the H-1130 PTO Driven Tub Grinder as of the date of publication. DuraTech Industries reserves the right to make updates to the machine from time to time. Even in the event of such updates, you should still find this manual to be appropriate for the safe operation and maintenance of your unit.

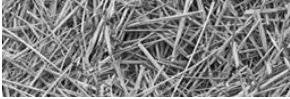
This manual, as well as materials provided by component suppliers to DuraTech Industries are all considered to be part of the information package. Every operator is required to read and understand these manuals, and they should be located within easy access for periodic review.

 **DURATECH**<sup>®</sup> &  are registered trademarks of Duratech Industries International, Inc. Haybuster, H-1130 and Big Bite with logo are trademarks of Duratech Industries International, Inc.

---



**HAYBUSTER<sup>®</sup>**  
*A Tradition of Innovation Since 1966*



## FOREWORD



## Foreword

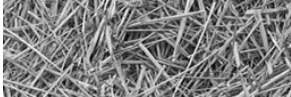
All personnel must read and understand the following sections before operating the H-1130 Tub Grinder.

- Foreword and Section 1, important safety information.
- Section 2, “Machine operation,” which explains normal operation of the machine.
- Section 2.1, “Pre-Operation Inspection”.

### Appropriate use of unit

The H-1130 Tilt Tub Grinder is designed to grind material into more palatable or manageable rations for your operation. It has multiple uses:

1. Grind most types of hay
  - Big round bales
  - Loose hay
  - Square bales
2. Grind most types of grain
  - Ear corn
  - Shell corn
  - High moisture corn



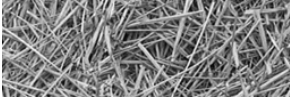
- Most small grains
3. Grind most types of crop residue
    - Stover
    - Straw
  4. Grind various sizes
    - Screens are available from 1/8" to 8"
    - Combine screen sizes to get desired cut

### **Operator protection**

As with all machinery, care needs to be taken in order to insure the safety of the operator and those in the surrounding area.



**WARNING:** The **OPERATOR IS RESPONSIBLE** for the safety of the operator and those in the surrounding area. Operators and those observing the operation of the H-1130 Tub Grinder are required to wear head, eye, and ear protection, No loose clothing is allowed.



**TABLE OF CONTENTS**

**Part 1: Operating Instructions ..... 1**

**Introduction ..... 2**

**Purpose ..... 2**

**Section 1: Safety ..... 4**

1.1 Safety-alert symbols ..... 4

1.2 Operator - personal equipment ..... 6

1.3 Machine safety labels ..... 7

1.4 Thrown objects and operator safety ..... 11

1.5 Shielding ..... 12

1.6 Personal protection equipment ..... 12

1.7 Safety Review ..... 13

1.8 Fire Prevention ..... 15

1.9 Fire Extinguishers: ..... 16

1.10 Towing ..... 17

1.11 Service and maintenance ..... 18

**Section 2: Operation ..... 19**

**2.1 Pre-Operating Inspection ..... 19**

**2.2 Introduction to the machine ..... 21**

2.2.1 Description of the H-1130 Tub Grinder ..... 21

2.2.2 Overview of Operator’s Controls ..... 21

2.2.3 Electronic governor ..... 22

2.2.4 Rotor ..... 22

2.2.5 Screens ..... 23

2.2.6 Tub ..... 23

2.2.7 Slug Buster and Mill Grate ..... 23

2.2.8 Conveyors, Lifting and Folding ..... 24

2.2.9 Hydraulic Tilt Platform ..... 24

**2.3 Machine Operation ..... 25**

2.3.1 Tractor Set Up ..... 25

2.3.2 How to hook up to tractor ..... 26

2.3.3 How to disconnect from tractor ..... 26

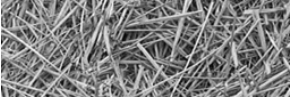
2.3.4 P.T.O. Shield ..... 27

2.3.5 How to operate machine as a unit ..... 27

**2.4 Shutdown procedures ..... 29**

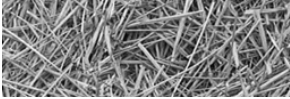
2.4.1 Normal Shutdown Procedure ..... 29

2.4.2 Emergency Shutdown Procedure ..... 29



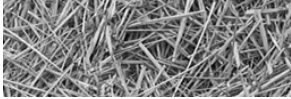
## TABLE OF CONTENTS

2.5	Storage.....	29
2.5.1	Preparing for storage .....	29
2.5.2	Removing from storage.....	30
2.6	Road Transport.....	30
2.6.1	Set up to transport .....	30
2.6.2	Change back to operate .....	30
2.7	Raising the Tub Platform.....	31
2.8	Parts of the electronic governor .....	32
2.9	Operation of the electronic governor.....	33
2.10	Calibration of the electronic governor .....	34
2.11	Adjusting the tub's rotation speed.....	34
2.12	Adjusting the conveyor belt tension .....	35
2.13	Adjusting the conveyor belt tracking .....	36
2.14	Adjusting tub chain tension.....	37
2.15	Main drive belt adjustment .....	38
2.16	Electro-hydraulic valve coil test.....	40
2.16a	Sensor test .....	41
2.17	Electro-hydraulic valve calibration .....	41
2.18	Belly auger drain covers .....	43
	<b>Section 3: General Maintenance .....</b>	<b>44</b>
3.1	Lubrication .....	45
3.2	Hydraulic system.....	51
3.3	Screens.....	52
3.4	Hammermill maintenance .....	53
3.5	Balanced Hammer maintenance and replacement.....	54
3.6	Dodge Rotor bearing installation .....	59
3.7	Installing pump drive chain coupler.....	62
	<b>Section 4: Troubleshooting the H-1130.....</b>	<b>63</b>
4.1	Troubleshooting the electronic governor system .....	63
4.2	General Troubleshooting .....	67
	<b>Appendix A: Warranty .....</b>	<b>68</b>

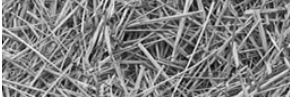


## TABLE OF CONTENTS

<b>Appendix B: H-1130 Specifications .....</b>	<b>69</b>
<b>Appendix C: Required for operation .....</b>	<b>70</b>
<b>H1130 Electric Tub Grinder Operators Manual Supplement ....</b>	<b>72</b>
Supplement Section 1: Set-Up (For S.N. 0651 And Up).....	72
Supplement Section 2: Start-Up (For S.N. Up To 0650) .....	73
Supplement Section 2: Start-Up (For S.N. 0651 And Up) .....	74
Supplement Section 3: Shut-Down Procedure (For S.N. Up To 0650) .....	75
Supplement Section 3: Shut-Down Procedure (For S.N. 0651 And Up).....	75
Supplement Section 3: Governor System.....	76
Supplement Section 4: Lubrication .....	77
Supplement Section 5: Raising/lowering the tub platform, raising/lowering the discharge conveyor, and folding/unfolding the discharge conveyor.....	79
Supplement Section 6: Hydraulic cooler .....	80
Supplement Section 7: Transport Hitch.....	81
<b>H-1130 Electric Specifications .....</b>	<b>82</b>
<b>Part 2: Parts Reference .....</b>	<b>83</b>
MAINFRAME ASSEMBLY #1 (S.N. UP TO 1110009530) .....	86
MAINFRAME ASSEMBLY #2 (S.N. UP TO 1110009530) .....	88
MAINFRAME ASSEMBLY #1 (S.N. 1110009630 THRU 111125030).....	90
MAINFRAME ASSEMBLY #2 (S.N. 1110009630 THRU 111125030).....	91
MAINFRAME ASSEMBLY DETAILS A & B (S.N. 1110009630 THRU 111125030).....	92
MAINFRAME ASSEMBLY #1 (S.N. 1112025130 & UP) .....	94
MAINFRAME ASSEMBLY #2 (S.N. 1112025130 & UP) .....	95
MAINFRAME ASSEMBLY DETAILS A & B (S.N. 1112025130 & UP).....	96
BELLY SIDE SHEETS .....	98
PLATFORM ASSEMBLY (S.N. UP TO 1110009530).....	100
PLATFORM ASSEMBLY (S.N. 1110009630 TO 1115070030).....	102
PLATFORM ASSEMBLY DETAIL A (S.N. 1110009630 TO 1115070030).....	104
PLATFORM ASSEMBLY (S.N. 1116071930 AND UP) .....	106
PLATFORM ASSEMBLY DETAIL A (S.N. 1116071930 AND UP).....	108
BULL WHEEL ASSEMBLY (S.N. UP TO 1111025030).....	110
BULL WHEEL ASSEMBLY (S.N. 1112025130 & UP).....	112
ROTOR ASSEMBLY (SN UP TO 111J005030) .....	114
ROTOR ASSEMBLY (S.N. 1110010130 TO 1111021930).....	116
ROTOR ASSEMBLY (S.N. 1111022030 UP TO 1117090030).....	118
ROTOR ASSEMBLY (S.N. 1118090130 AND UP).....	120
PUMP DRIVE COUPLER.....	122
TUB DRIVE ASSEMBLY .....	124
TUB ASSEMBLY .....	126
HITCH / DRIVE LINE ASSEMBLY.....	128

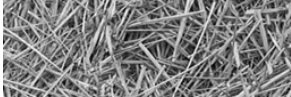


BELLY CONVEYOR AUGER ASSEMBLY #1 (UP TO S.N. 1113040030).....	130
BELLY CONVEYOR AUGER ASSEMBLY #2 (UP TO S.N. 1113040030).....	131
BELLY CONVEYOR AUGER ASSEMBLY DETAIL A (UP TO S.N. 1113040030) .....	132
BELLY AUGER ASSEMBLY (S.N. 1113040130 AND UP) .....	134
LOWER DISCHARGE CONVEYOR ASSEMBLY (S.N. UP TO 1110010030) .....	136
LOWER DISCHARGE CONVEYOR ASSEMBLY (S.N. 1110010130 TO 1113040030).....	138
LOWER DISCHARGE CONVEYOR ASSEMBLY (S.N. 1113040130 AND UP).....	140
UPPER DISCHARGE CONVEYOR ASSEMBLY (S.N. UP TO 1110010030).....	142
UPPER DISCHARGE CONVEYOR ASSEMBLY (S.N. 1110010030 TO 1117090030) .....	144
UPPER DISCHARGE CONVEYOR ASSEMBLY (S.N. 1118090130 AND UP).....	146
HYDRAULIC OIL TANK ASSEMBLY.....	148
4300078 SERVO 5 GPM VALVE.....	150
TANDUM HYDRAULIC PUMP .....	151
4000429 HYDRAULIC SOLENOID VALVE.....	152
4000430 RELIEF VALVE.....	153
4300431 3-POS 4-WAY HYDRAULIC VALVE .....	154
4300432 2-POS 4-WAY HYDRAULIC VALVE .....	155
4000423 2-BANK HYDRAULIC VALVE .....	156
MACHINE HYDRAULICS SCHEMATIC.....	157
OIL TANK HYDRAULICS.....	158
TANDUM PUMP HYDRAULICS .....	160
TUB FLOW CONTROL HYDRAULICS .....	162
SOLENOID HYDRAULIC VALVE.....	164
FIXED FLOW CONTROL VALVE HYDRAULICS (S.N. UP TO 1110010030) .....	166
FIXED FLOW CONTROL VALVE HYDRAULICS (S.N. 1110010130 TO 1113040030).....	168
FIXED FLOW CONTROL VALVE HYDRAULICS (S.N. 1113040130 AND UP).....	170
CONVEYOR ON/OFF VALVE HYDRAULICS .....	172
TUB ROTATION VALVE AND TUB ORBIT MOTOR (S.N. UP TO 1110010030) .....	174
TUB ROTATION VALVE AND TUB ORBIT MOTOR (S.N. 1110010130 AND UP)....	176
CONVEYOR FOLD/UNFOLD & RAISE/LOWER VALVE HYDRAULICS.....	178
TUB TILT HYDRAULICS .....	180
BELLY AUGER ORBIT MOTOR HYDRAULICS (S.N. UP TO 1113040030) .....	182
BELLY AUGER HYDRAULICS & GREASE LINES #1 (S.N. 1113040130 AND UP) .	184
BELLY AUGER HYDRAULICS & GREASE LINES #2 (S.N. 1113040130 AND UP) .	185
CONVEYOR LIFT AND FOLD CYLINDER HYDRAULICS .....	188
CONVEYOR FLOW CONTROL VALVE HYDRAULICS (S.N. UP TO 1113040030)..	190
CONVEYOR FLOW CONTROL VALVE HYDRAULICS (S.N. 1113040130 AND UP) .....	192
DISCHARGE CONVEYOR ORBIT MOTOR HYDRAULICS.....	194
PRESSURE GAUGES (S.N. 1110010130 AND UP).....	196
WHEELS AND HUBS.....	198



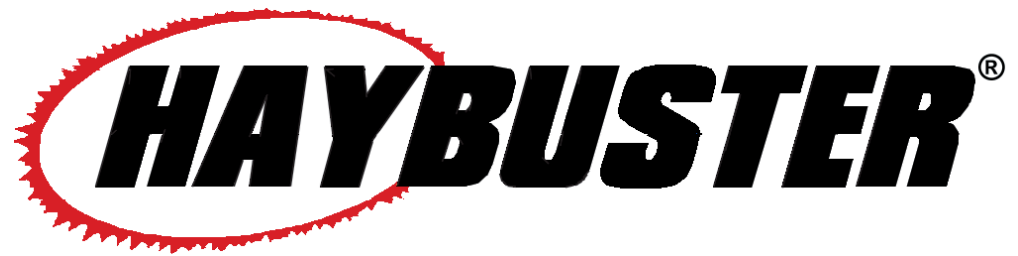
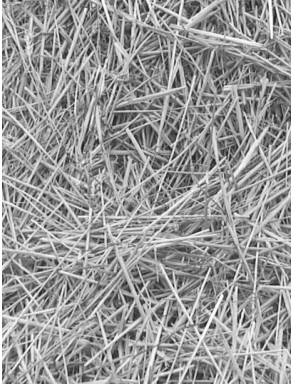
## TABLE OF CONTENTS

ORBIT MOTOR.....	200
3600698 PTO ASSEMBLY .....	202
3600699 PTO ASSEMBLY .....	203
3600700 PTO ASSEMBLY .....	204
3600768 PTO ASSEMBLY .....	205
PRESSURE ROLLER ASSEMBLY .....	206
TUB ROLLER BEARING ASSEMBLY .....	207
TRACTOR POWERED FUNCTIONS HYDRAULIC SCHEMATIC .....	208
TUB / CONVEYOR HYDRAULIC CIRCUIT .....	209
HYDRAULIC CYLINDER SEALS AND OTHER ITEMS .....	210
ELECTRONIC GOVERNOR ASSEMBLY .....	212
GRAIN HOPPER #1 (OPTION).....	214
GRAIN HOPPER #2 (OPTION).....	216
MILL GRATE / SLUGBAR COMBINATION (OPTION) (FOR S.N. UP TO 1115070030).....	218
MILL GRATE - 9 BAR - 2-1/2" (FOR S.N. 1116071930 TO 1117090030) .....	220
MILL GRATE - 9 BAR - 2-1/2" (FOR S.N. 1118090130 AND UP) .....	222
EAR CORN KIT (OPTION).....	224
GEYSER PLATE (OPTION) (FOR S.N. UP TO 1115070030).....	226
GEYSER PLATE (OPTION) (FOR S.N. 1116071930 AND UP) .....	228
MATERIAL GUIDE ASSEMBLY (OPTION).....	230
DECALS .....	232
DECAL LOCATIONS.....	234
5700845 H-1130 WIRING HARNESS.....	235
5700902 OPTIONAL POWER HARNESS.....	236
<b>STATIONARY ELECTRIC TUB GRINDER SUPPLEMENT .....</b>	<b>237</b>
ELECTRIC MAINFRAME ASSEMBLY #1 .....	238
ELECTRIC MAINFRAME ASSEMBLY #2.....	240
ELECTRIC MAINFRAME ASSEMBLY #3.....	242
ELECTRIC MOTOR ASSEMBLY #1 (S.N. UP TO 0650).....	244
ELECTRIC MOTOR ASSEMBLY #2 (S.N. UP TO 0650).....	246
ELECTRIC MOTOR ASSEMBLY #1 (S.N. 0651 & UP).....	248
ELECTRIC MOTOR ASSEMBLY #2 (S.N. 0651 & UP).....	250
OFFSET BULL WHEEL .....	252
MILL GRATE - 9 BAR - 3" .....	254
400477 - 2 BANK HYDRAULIC VALVE .....	256
400478 - 1 BANK HYDRAULIC VALVE .....	258
HYDRAULIC COOLER .....	260
TUB PLATFORM VALVE HYDRAULICS.....	262
OIL TANK HYDRAULICS .....	264



CONVEYOR ON/OFF VALVE HYDRAULICS .....	266
CONVEYOR FOLD/UNFOLD & RAISE/LOWER VALVE HYDRAULICS...	268
CONVEYOR FOLD/UNFOLD & RAISE/LOWER VALVE HYDRAULICS DETAILS B-D.....	270
CASSAPA PUMP.....	272
AUXILLARY HYDRAULIC SCHEMATIC .....	274
TUB/CONVEYOR HYDRAULIC CIRCUIT (S.N. UP TO 113040030) .....	275
1130 TUB/TWIN AUGER CONVEYOR HYDRAULIC CIRCUIT (S.N. 113040130 AND UP).....	276
5700975 ELECTRIC HARNESS.....	277
SCHEMATIC 460 VOLT #1 .....	278
SCHEMATIC 460 VOLT #2 .....	279
SCHEMATIC 460 VOLT #3 .....	280

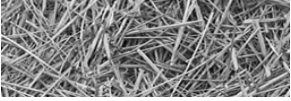
**H-1130 TUB GRINDER DOCUMENTATION COMMENT FORM .. 281**



# **H-1130<sup>TM</sup>**

## **PTO Driven Tub Grinder**

### **Part 1: Operating Instructions**



# Introduction

The H-1130 Tub Grinder is designed to grind material into more palatable or manageable rations for your operation. It has multiple uses:

1. Grind most types of hay
  - Big round bales
  - Loose hay
  - Square bales
2. Grind most types of grain
  - Ear corn
  - Shell corn
  - High moisture corn
  - Most small grains
3. Grind most types of crop residue
  - Stover
  - Straw
4. Grind various sizes
  - Screens are available from 1/8" to 8"
  - Combine screen sizes to get desired cut

To avoid possible damage to the machine and risk of injury to the operator, consult with a DuraTech Industries International, Inc. (DuraTech Industries) representative before attempting to shred materials other than livestock forage.

## Purpose

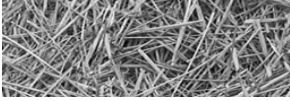
The purpose of this owner's manual is to explain maintenance requirements and routine adjustments for the most efficient operation of your H-1130 Tub Grinder. There is also a trouble shooting section that may help in case of problems in the field. Any information not covered in this manual may be obtained from your dealer.



**Special Note:** When reference is made as to front, rear, left hand, or right hand of this machine, the reference is always made from standing at the rear end of the machine and looking toward the hitch. Always use serial number and model number when referring to parts or problems. Please obtain your serial number and write it below for your future reference.

MODEL: H-1130

SERIAL NO. \_\_\_\_\_



## How to use this manual

### Manual organization

This manual is organized into the following parts:

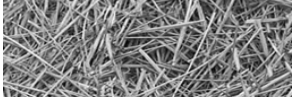
- **Part 1:** Operating Instructions
  - **Section 1:** Safety decals, safety instructions and information
  - **Section 2:** Describes the purposes of each part, and safe operating procedures.
  - **Section 3:** Describes how to maintain the H-1130 Tub Grinder.
  - **Section 4:** Describes how to trouble shoot problems with the H-1130 Tub Grinder.
- **Part 2:** Part's reference contains diagrams of each assembly, with the part number of each part. A key on the same or facing page contains a description of the part and the quantity used.

### Dealer responsibilities

- Perform a daily pre-operation inspection as described in Section 2, "Operation."
- Upon delivery of the unit to the customer, it is your responsibility to conduct a training session on the safe operation of the unit for the primary operator(s). You must also conduct a "walk-around" inspection of all safety instructional decals on the machine itself. Decals are illustrated in **Part 2: Parts Reference**.
- Complete and return the Warranty Registration postcard. DuraTech Industries must receive this form before activating the warranty. Appendix A provides details of the warranty.

### Operator responsibilities

- Note the important safety information in the Foreword and in Section 1, "Safety."
- Thoroughly review sections 1 and 2, which explain normal operation of the machine, and section 3, which explains maintenance requirements. These sections will function as your textbook during the dealer-conducted training course that is required before you can use the unit.
- Manuals for certain allied supplier's components are provided separately. You should also be familiar with their contents.
- Keep copies of all manuals in a readily accessible location for future reference.



## Section 1: Safety

The safety of the operator is of great importance to DuraTech Industries/Haybuster. We have provided decals, shield and other safety features to aid you in using your machine safely. In addition, we ask you to be a careful operator who will properly use and service your Haybuster equipment.



**WARNING:** FAILURE TO COMPLY WITH SAFETY INSTRUCTIONS THAT FOLLOW WITHIN THIS MANUAL COULD RESULT IN SEVERE PERSONAL INJURY OR DEATH. BEFORE ATTEMPTING TO OPERATE THIS MACHINE, CAREFULLY READ ALL INSTRUCTIONS CONTAINED WITHIN THIS MANUAL. ALSO READ THE INSTRUCTION MANUAL PROVIDED WITH YOUR TRACTOR.

**THIS MACHINE IS NOT TO BE USED FOR ANY PURPOSE OTHER THAN THOSE EXPLAINED IN THE OPERATOR'S MANUAL, ADVERTISING LITERATURE OR OTHER DURATECH INDUSTRIES WRITTEN MATERIAL PERTAINING TO THE H-1130 TUB GRINDER.**

### 1.1 Safety-alert symbols

Decals are illustrated in **Part 2: Parts Reference**.

The safety decals located on your machine contain important and useful information that will help you operate your equipment safely.

To assure that all decals remain in place and in good condition, follow the instructions below:

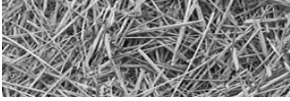
- Keep decals clean. Use soap and water - not mineral spirits, adhesive cleaners and other similar cleaners that will damage the decal.
- Replace all damaged or missing decals. When attaching decals, surface temperature of the machine must be at least 40° F (5° C). The surface must be also be clean and dry.
- When replacing a machine component to which a decal is attached, be sure to also replace the decal.
- Replacement decals can be purchased from your Haybuster dealer.

DuraTech Industries uses industry accepted **ISO/ANSI** standards in labeling its products for safety and operational characteristics.



### **Safety-Alert Symbol**

Read and recognize safety information. Be alert to the potential for personal injury when you see this safety-alert symbol.



**DANGER:** Indicates an imminently hazardous situation that, if not avoided, will result in death or serious injury. This signal word is to be limited to the most extreme situations, typically for machine components that, for functional purposes, cannot be guarded.



**DANGER:**  
Signal word - White Lettering/Red Background  
Safety Alert Symbol - White Triangle/Red Exclamation Point

**WARNING:** Indicates a potentially hazardous situation that, if not avoided, could result in death or serious injury, and includes hazards that are exposed when guards are removed. It may also be used to alert against unsafe practices.



**WARNING:**  
Signal word - Black Lettering/Orange Background  
Safety Alert Symbol - Black Triangle/Orange Exclamation Point

**CAUTION:** Indicates a potentially hazardous situation that, if not avoided, may result in minor or moderate injury. It may also be used to alert against unsafe practices.



**CAUTION:**  
Signal word - Black Lettering/Yellow Background  
Safety Alert Symbol - Black Triangle/Yellow Exclamation Point

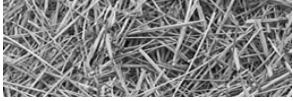
This manual uses the symbols to the right to denote important safety instructions and information.

The **DANGER**, **WARNING** and **CAUTION** symbols are used to denote conditions as stated in the text above. Furthermore, the text dealing with these situations is surrounded by a box with a white background, will begin with **DANGER**, **WARNING**, or **CAUTION**.

The **INFORMATION** symbol is used to denote important information or notes in regards to maintenance and use of the machine. The text for this information is surrounded by a box with a light grey background, and will begin with either **IMPORTANT** or **NOTE**.



	<p>1. Yellow warning triangle/black graphical symbol, indicates what the hazard is. Hazard Identification</p>
	<p>2. Red circle-with-slash/black graphical symbol indicates a prohibited action to avoid the hazard. Prohibited Action</p>
	<p>3. Blue mandatory action circles/white graphical symbol - indicates an action to take to avoid the hazard. Mandatory Action</p>



## 1.2 Operator - personal equipment

### THE OPERATOR

#### Physical Condition

You must be in good physical condition and mental health and not under the influence of any substance (drugs, alcohol) which might impair vision, dexterity or judgment.

Do not operate a **H-1130** when you are fatigued. Be alert - If you get tired while operating your **H-1130**, take a break. Fatigue may result in loss of control. Working with any farm equipment can be strenuous. If you have any condition that might be aggravated by strenuous work, check with your doctor before operating

#### Proper Clothing



Clothing must be sturdy and snug-fitting, but allow complete freedom of movement. Avoid loosefitting jackets, scarfs, neckties, jewelry, flared or cuffed pants, unconfined long hair or anything that could become entangled with the machine.



Protect your head with a hard hat to reduce the risk of injury from flying debris.



Protect your hands with gloves when handling hammers, screens, etc... Heavy-duty, nonslip gloves improve your grip and protect your hands.



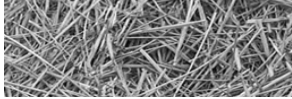
Good footing is most important. Wear sturdy boots with nonslip soles. Steel-toed safety boots are recommended.



To reduce the risk of injury to your eyes never operate a **H-1130** unless wearing goggles or properly fitted safety glasses with adequate top and side protection.




Tractor noise may damage your hearing. Always wear sound barriers (ear plugs or ear muffers) to protect your hearing. Continual and regular users should have their hearing checked regularly.




### 1.3 Machine safety labels

The safety decals located on your machine contain important information that will help you operate your equipment. Become familiar with the decals and their locations.

 **DANGER:** ROTATING PARTS WITHIN CAN KILL OR DISMEMBER. WAIT FOR ALL MOVEMENT TO STOP BEFORE SERVICING, UNLOADING, OR INSPECTING MACHINE.

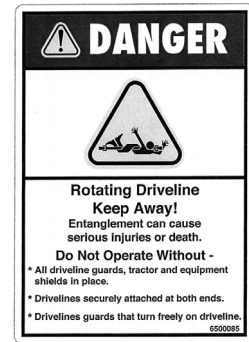


6500082


 **DANGER:** ROTATING DRIVELINE, CONTACT CAN CAUSE DEATH, KEEP AWAY!

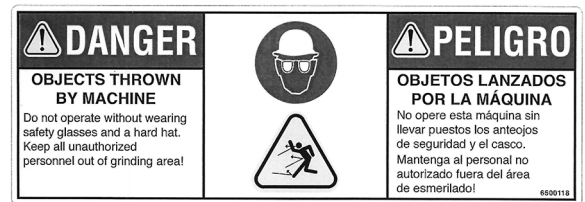
DO NOT OPERATE WITHOUT

- ALL DRIVELINE GUARDS, TRACTOR AND EQUIPMENT SHIELDS IN PLACE
- DRIVELINES SECURELY ATTACHED AT BOTH ENDS
- DRIVELINE GUARDS THAT TURN FREELY ON DRIVELINE




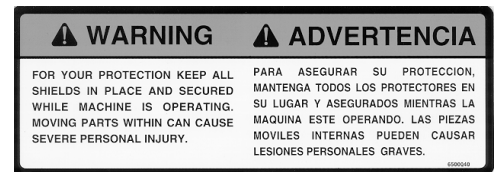
6500085

 **DANGER: OBJECTS THROWN BY MACHINE** DO NOT OPERATE WITHOUT WEARING SAFETY GLASSES AND A HARD HAT. KEEP UNAUTHORIZED PERSONNEL OUT OF THE GRINDING AREA

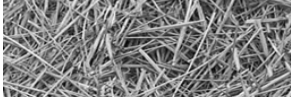


6500118

 **WARNING:** FOR YOUR PROTECTION KEEP ALL SHIELDS IN PLACE AND SECURED WHILE MACHINE IS OPERATING MOVING PARTS WITHIN CAN CAUSE SEVERE PERSONAL INJURY.



6500040



**WARNING: FOR YOUR PROTECTION AND PROTECTION OF OTHERS, PRACTICE THE FOLLOWING SAFETY RULES.**

1. BEFORE OPERATING THIS MACHINE, READ THE OPERATOR'S MANUALS SUPPLIED WITH THIS MACHINE AND YOUR TRACTOR.
2. CHECK OPERATORS MANUALS TO BE SURE YOUR TRACTOR MEETS THE MINIMUM REQUIREMENTS FOR THIS MACHINE.
3. READ ALL DECALS PLACED ON THIS MACHINE FOR YOUR SAFETY AND CONVENIENCE.
4. NEVER ALLOW RIDERS ON THIS IMPLEMENT OR THE TRACTOR.
5. KEEP OTHERS AWAY FROM THIS MACHINE WHILE IN OPERATION.
6. KEEP ALL SHIELDS IN PLACE WHILE MACHINE IS OPERATING.
7. KEEP HANDS, FEET, LOOSE CLOTHING, ETC., AWAY FROM POWER DRIVEN PARTS.
8. ALWAYS SHUT OFF MACHINE AND ENGINE BEFORE SERVICING, UNCLOGGING, INSPECTING, OR WORKING NEAR THIS MACHINE FOR ANY REASON. ALWAYS PLACE TRANSMISSION IN PARK OR SET PARK BRAKE AND WAIT FOR ALL MOVEMENT TO STOP BEFORE APPROACHING THIS MACHINE.





**WARNING: NO RIDERS**  
SERIOUS INJURY COULD RESULT FROM RIDING ON THE MACHINE.



**WARNING: THROWN OBJECT HAZARD**  
TO PREVENT SERIOUS INJURY OR DEATH DO NOT RAISE TUB WHEN ROTOR IS TURNING.

1. DISENGAGE ROTOR AND ALLOW TO COME TO A COMPLETE STOP.
2. BE CERTAIN THAT ALL PERSONNEL ARE CLEAR OF MACHINERY AREA.
3. RAISE TUB TO FULL VERTICAL POSITION.
4. STOP ENGINE AND REMOVE KEY BEFORE APPROACHING TUB AND ROTOR AREA.

 <b>WARNING</b>	 <b>ADVERTENCIA</b>
<b>FOR YOUR PROTECTION AND SAFETY OF OTHERS, FOLLOW THESE SAFETY RULES.</b>	<b>PARA SU PROTECCIÓN Y LA SEGURIDAD DE OTROS, OBSERVE ESTAS NORMAS DE SEGURIDAD</b>
<ol style="list-style-type: none"> <li>1. Read and understand operator manual before operating machine.</li> <li>2. Place all controls in neutral, stop engine, remove ignition key, lock out power source, and wait for all motion to stop before servicing, adjusting, repairing, or untagging.</li> <li>3. Read and understand all decals on machine for your safety.</li> <li>4. Keep all people in place while machine is in operation.</li> <li>5. Keep hands, feet, hair, and clothing away from moving parts.</li> <li>6. Keep others away from machine while in operation.</li> <li>7. Fuel safety: Never before transporting, or working near any components.</li> <li>8. Do not allow riders at any time.</li> <li>9. Do not leave machine unattended with engine running.</li> <li>10. Keep all hydraulic lines, couplings, and fittings free of leaks during operation.</li> <li>11. Keep away from overhead electrical lines. Electrocutation can occur without direct contact.</li> <li>12. Review safety instructions periodically.</li> </ol>	<ol style="list-style-type: none"> <li>1. Lea y comprenda el manual del operador antes de operar la máquina.</li> <li>2. Coloque todos los controles en punto neutro, apague el motor, retire la llave de encendido, cierre los elementos de de potencia y espere a que se detenga todo el movimiento antes de proceder al servicio, ajuste, reparación o desmontaje.</li> <li>3. Lea y comprenda todas las calcomanías adheridas a la máquina para su seguridad.</li> <li>4. Mantenga todas las personas en su lugar mientras la máquina está en funcionamiento.</li> <li>5. Mantenga las manos, pies, cabello y ropa lejos de las partes en movimiento.</li> <li>6. Mantenga a otras personas alejadas de la máquina en funcionamiento.</li> <li>7. Mantenga áreas de seguridad antes de proceder al transporte o a trabajar durante las operaciones.</li> <li>8. No permita en ningún momento que otras personas vayan en la máquina.</li> <li>9. No deje la máquina sin que nadie esté al motor encendido.</li> <li>10. Mantenga todas las líneas hidráulicas, acoplamientos y accesorios sin fugas durante el funcionamiento.</li> <li>11. Manténgase alejado de las líneas eléctricas elevadas. Puede producirse la electrocución sin contacto directo.</li> <li>12. Analice las instrucciones de seguridad en forma periódica.</li> </ol>

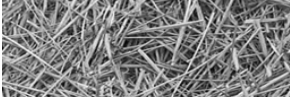
6500041

 <b>WARNING</b>		 <b>ADVERTENCIA</b>
<b>No Riders</b> Serious personal injury could result from riding on the machine.		<b>Pasajeros Prohibidos</b> Podrían resultar lesiones personales graves al viajar en la máquina.

6500043

 <b>WARNING</b>	 <b>ADVERTENCIA</b>
<b>THROWN OBJECT HAZARD</b> TO PREVENT SERIOUS INJURY OR DEATH DO NOT RAISE TUB WHEN ROTOR IS TURNING.	<b>PELIGRO DE OBJETOS DESPEDIDOS</b> PARA PREVENIR LESIONES SERIAS O LA MUERTE NO ELEVE LA CUBA CUANDO EL ROTOR ESTE GIRANDO.
<ol style="list-style-type: none"> <li>1. DISENGAGE ROTOR AND ALLOW TO COME TO A COMPLETE STOP.</li> <li>2. BE CERTAIN THAT ALL PERSONNEL ARE CLEAR OF MACHINERY AREA.</li> <li>3. RAISE TUB TO FULL VERTICAL POSITION.</li> <li>4. STOP ENGINE AND REMOVE KEY BEFORE APPROACHING TUB AND ROTOR AREA.</li> </ol>	<ol style="list-style-type: none"> <li>1. DISENGAGE ROTOR AND ALLOW TO COME TO A COMPLETE STOP.</li> <li>2. BE CERTAIN THAT ALL PERSONNEL ARE CLEAR OF MACHINERY AREA.</li> <li>3. RAISE TUB TO FULL VERTICAL POSITION.</li> <li>4. STOP ENGINE AND REMOVE KEY BEFORE APPROACHING TUB AND ROTOR AREA.</li> </ol>

6500209



**WARNING: OVERHEAD CONVEYOR HAZARD  
TO PREVENT SERIOUS INJURY OR DEATH:**

DO NOT WALK UNDER CONVEYOR AT ANY TIME. STAY CLEAR OF CONVEYOR DURING OPERATION, RAISING, AND LOWERING. LOWER CONVEYOR FULLY BEFORE SERVICING.

KEEP OTHERS AWAY.



6500214



**WARNING: HIGH-PRESSURE FLUID HAZARD, TO  
PREVENT SERIOUS INJURY OR DEATH:**

- RELIEVE PRESSURE ON SYSTEM BEFORE REPAIRING OR ADJUSTING OR DISCONNECTING.
- WEAR PROPER HAND AND EYE PROTECTION WHEN SEARCHING FOR LEAKS. USE WOOD OR CARDBOARD INSTEAD OF HANDS.
- KEEP ALL COMPONENTS IN GOOD REPAIR.

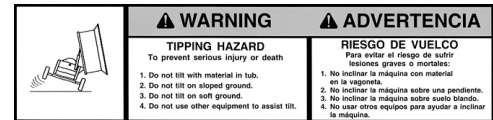


6500220



**WARNING: TIPPING HAZARD  
TO PREVENT SERIOUS INJURY OR DEATH**

1. DO NOT Tilt WITH MATERIAL IN TUB.
2. DO NOT Tilt ON SLOPED GROUND.
3. DO NOT Tilt ON SOFT GROUND.
4. DO NOT USE OTHER EQUIPMENT TO ASSIST Tilt.

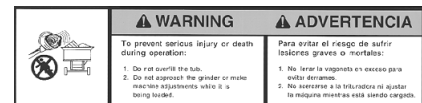


6500282



**WARNING: TO PREVENT SERIOUS INJURY OR  
DEATH DURING OPERATION:**

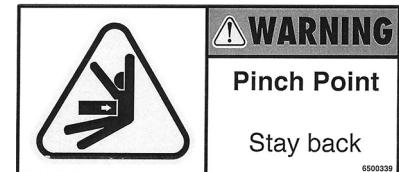
1. DO NOT OVERFILL THE TUB.
2. DO NOT APPROACH THE GRINDER OR MAKE MACHINE ADJUSTMENTS WHILE IT IS BEING LOADED.



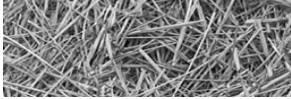
6500283



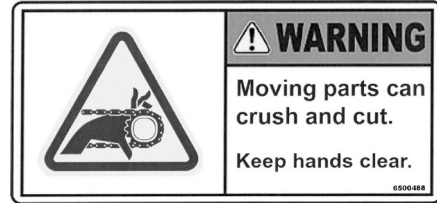
**WARNING: PINCH POINT STAY BACK**



6500339



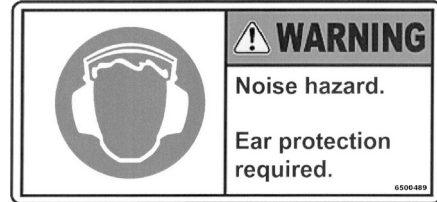
**WARNING:** Moving parts can crush and cut.  
Keep hands clear.



6500488



**WARNING:** Noise hazzard.  
Ear protection required.



6500489



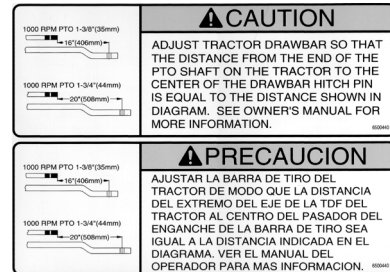
**WARNING:** No Step.  
Do not step, stand or sit on this surface.  
May cause injury and /or equipment damage.



6500490



**CAUTION:** ADJUST TRACTOR DRAWBAR SO THAT THE DISTANCE FROM THE END OF THE PTO SHAFT ON THE TRACTOR TO THE CENTER OF THE DRAWBAR HITCH PIN IS EQUAL TO THE DISTANCE SHOWN IN DIAGRAM. SEE OWNER'S MANUAL FOR MORE INFORMATION.



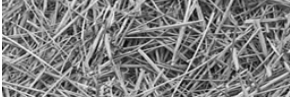
6500440



**CAUTION:** Do not operate machine unless an approved fire extinguisher is installed.



6500497



## 1.4 Thrown objects and operator safety

An operational characteristic of all grinders is that objects may be thrown out of the hopper. Thrown objects may present a safety hazard to persons in the area. This section is to inform the operator of this characteristic, and what can be done to reduce the risk of injury to the operator and persons in the area. Keep all observers away from the machine.

Figure 1.1 shows an object being hit as the hammer is on the upswing. A general pattern for where thrown objects may land is shown in Figure 1.2.

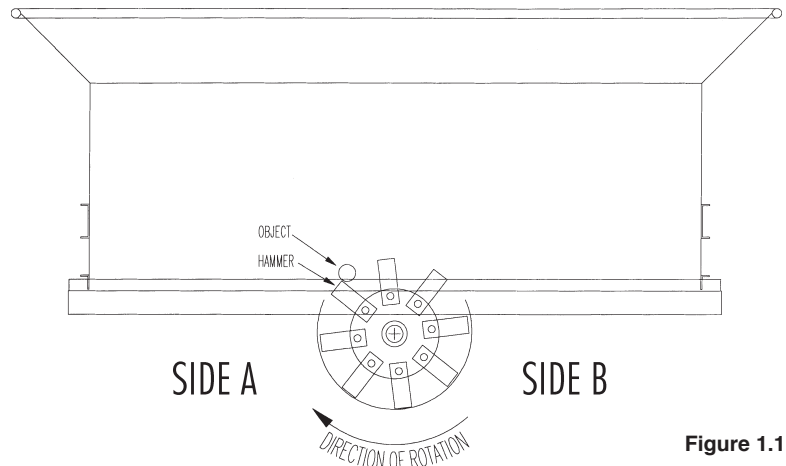


Figure 1.1

VIEWED FROM THE REAR OF THE H-1130



**NOTE:** The difference in the size of the area for side A versus side B. Side B is larger.

Dimensioning the size of this area is not practical. The distance a thrown object may travel is dependent on several conditions, including, but not limited to, rotor speed and diameter, condition of the hammers, style of hammers, object mass, object shape, amount of material in the tub, and how the hammer strikes the object.

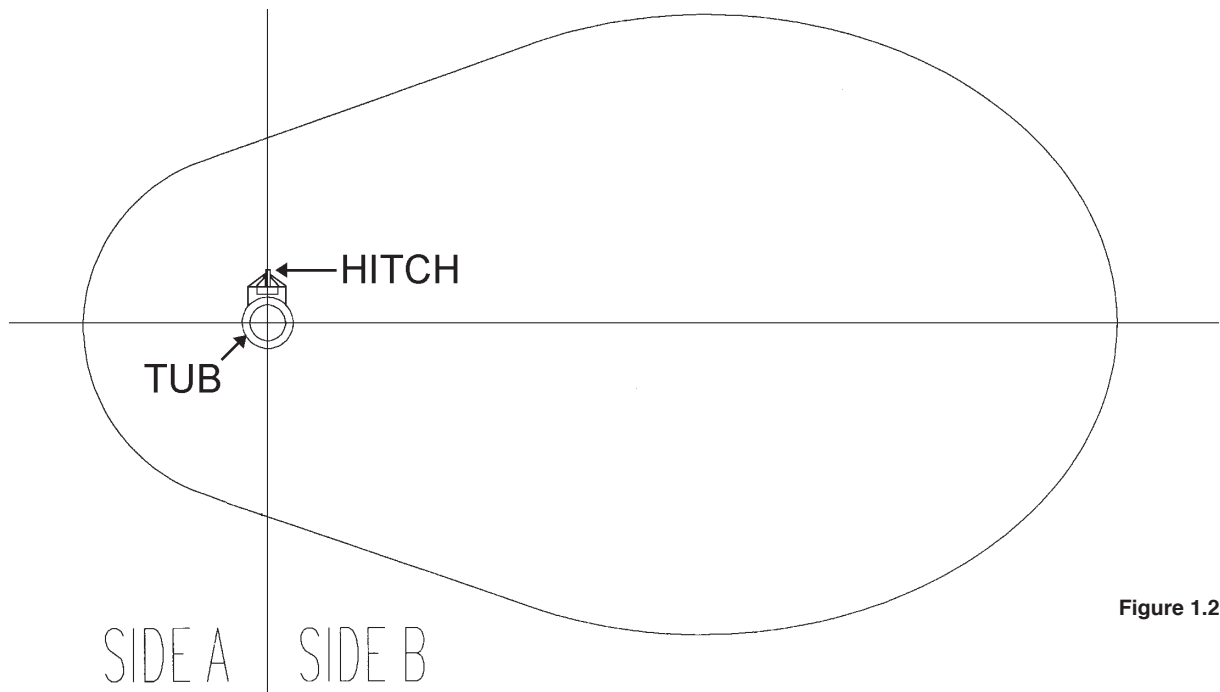
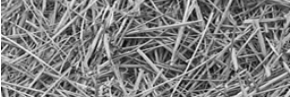


Figure 1.2



The amount of material in the tub can dampen or stop the object's potential flight. Keeping the tub full will reduce the risks. Filling the tub at least 1/2 full when starting will reduce the risk. Using a geyser plate can help reduce thrown objects. A risk may arise when the tub is being emptied, such as at the end of the grind. Running the engine at slower speeds when starting or finishing the grind will also help, especially slowing down when emptying the tub.



**WARNING:** To minimize the potential risk of injury or property damage, the operator must:

- a) Place side B towards open areas, away from property and people.
- b) Load the grinder from side A with a loader equipped with an enclosed cab.
- c) Keep observers out of the area.
- d) Wear a hard hat and safety glasses, at a minimum, and require that any other persons in the area are similarly equipped.

## 1.5 Shielding

This H-1130 Tub Grinder is equipped with shielding at all major points of potential injury. All Shields should be kept in place during operation. Bodily injury may occur if the unit is operated without shields.



**WARNING:** Shields are installed for your protection and to keep material off machine parts. Do not operate this Industrial Tub Grinder without shields in place.

## 1.6 Personal protection equipment

Operators and authorized observers of the H-1130 Tub Grinder are required to wear head, eye, and ear protection. No loose clothing is allowed.



## 1.7 Safety Review



**WARNING:** Before attempting to operate your H-1130 Tub Grinder, carefully read and follow instructions given below and contained elsewhere in this manual.

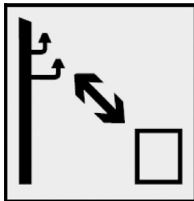
### BEFORE OPERATING

1. Read and follow all instructions contained in:
  - Operators Manual
  - Tractor Operators Manual
  - Decals placed on H-1130 Tub Grinder.

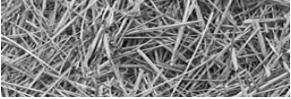


**NOTE:** Your dealer has additional copies of these materials.

2. Allow only properly instructed, responsible individuals to operate your machine. Carefully supervise inexperienced operators.
3. Use a tractor that meets the requirements contained in this manual. **See Appendix C, Required for Operation, page 63.**
4. Make sure the H-1130 Tub Grinder is in good operating condition and that all protective shields are in place and in proper working order. Replace damaged shields before operating.
5. Be sure all bystanders and other workers are clear before starting tractor and grinder.
6. Make no modifications to the H-1130 Tub Grinder unless specifically recommended or requested by DuraTech Industries.
7. Check periodically for broken or worn parts and make necessary repairs.
8. Be sure the unit is securely attached to tractor during grinder operation and road transport.



Keep sufficient distance away from electrical power lines.  
**WARNING:** Electrocutation is possible when running this machine during an electric storm or heavy fog.



## DURING OPERATION

1. Enforce the following safety precautions to prevent serious personal injury.
  - Keep everyone clear of work area except operator seated at tractor controls.
  - **Never work on or near grinder unless engine is off, and all motion has stopped.**
  - Disengage PTO before starting engine.
2. Power take off shafts must be locked in place with protective PTO shields in place.
3. Keep hands, feet, and clothing away from power driven parts.
4. Keep shields in place and in good condition.
5. Watch out for and avoid any object that might interfere with the proper operation of the machine.
6. Loose clothing, necklaces, and similar items are more easily caught in moving parts. Avoid the use of these items and keep long hair confined.
7. Because it is possible that your H-1130 may be used in dry areas or the presence of combustibles, special precautions should be taken to prevent fires and fire fighting equipment should be readily available.



NO SMOKING IN THIS AREA



DANGER! NO OPEN FLAMES IN THIS AREA

8. Never allow riders on the machine at any time.

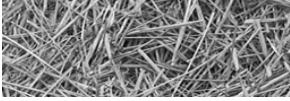


## NORMAL SHUTDOWN PROCEDURE



**WARNING:** For your safety and the safety of others, you must use the following normal shutdown procedure before leaving the controls unattended for any reason, including servicing, cleaning, or inspecting. A variation of the following procedure may be used if so instructed within this manual or if an extreme emergency requires it.

1. Run H-1130 Tub Grinder until discharge conveyor is empty, and grind as much of the material in the tub as possible.
2. Reduce engine speed to idle.
3. Disengage PTO
4. Disengage hydraulics.
5. Place transmission in park and set parking brake.
6. Shut off tractor engine and remove key.
7. Wait for all movement to stop.
8. Disconnect PTO driveline from tractor.



## 1.8 Fire Prevention

Grinding wood, hay, and other products in a tub grinder produces a large amount of potentially combustible material. The risks of fire can be significantly reduced with proper operating and maintenance procedures. This does include frequent removal of dust, debris, and other combustible materials.

Most of the products that are ground are dry and the grinding process can produce fine, dusty material. The grinding process can produce heat and the spinning rotor will circulate air within the grinding chamber. For a fire to start, fuel, oxygen and heat in sufficient quantity, must be present. During normal operation and with a properly maintained tub grinder, the material being ground will move through the grinding chamber so quickly that it doesn't have a chance to heat up sufficiently to start a fire. Also, the rapid rate that a tub grinder can pile material will quickly smother small hot spots that might occur during normal grinding operations. Keeping the material moving through the machine and across the top of the rotor is important to keep frictional heating of the material to a minimum.

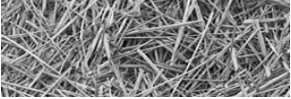
**NEVER** leave the vicinity of the unit with the engine running.

### PROPER OPERATION OF THE TUB GRINDER:

- Do not grind materials any finer than necessary. Finely ground materials will produce more dust and increase the risk of fire. If finely ground materials are required, it is better to grind the materials coarse first with large opening screens installed in the grinder and then regrind them to the desired consistency by installing smaller opening screens in the grinder. Be especially cautious when grinding materials that can burn easily.
- When filling the tub grinder during start-up begin by filling the rear of the tub and avoid placing materials on the spinning rotor. When material begins to fall over the rotor, set the governor control on "Manual" and rotate the tub slowly while continuing to fill the tub. Use the tub cover to control thrown objects as much as possible. When the tub is 1/2 to 2/3 full, the governor control can be set to "auto" and grinding operations can resume normally. Do not allow the tub to stop for any significant amount of time with material over the rotor to minimize frictional heating.
- Do not smoke when working with combustible materials.

### REMOVAL AND CLEANING INSTRUCTIONS:

- Clean the engine compartment or electric motor area daily or more often if conditions require it be done more frequently. When cleaning the engine compartment, always clean the top of the engine and the areas around exhaust manifolds, exhaust plumbing and turbochargers.
- Check the rotor box for debris built up around the rotor. Remove material that may be packed tight near the bearings, on shaft or other rotating components because it will become hot due to friction.
- At shutdown, always clean and remove all dust, debris, or combustible material off the entire grinder. Use high-pressure air or water if necessary. Always move the grinder and all other equipment away from the ground material pile before leaving the job site in case of smoldering combustion in the ground material.



## TUB GRINDER MAINTENANCE:

- Repair any fuel or hydraulic leaks as quickly as they are discovered. Clean up spills immediately. Fuel or oil soaked materials can contribute significantly to the rapid spreading of a fire once it has begun.
- Inspect all electrical wiring periodically. Any chafed or damaged wires should be repaired immediately. Keep all electrical connections tight to prevent arcs or sparks.
- Contact between the rotor and any stationary component of the grinding chamber such as contact between the hammers and the screens must be corrected immediately.

## 1.9 Fire Extinguishers:



**CAUTION:** Do not operate machine unless an approved fire extinguisher is installed.

The fire extinguishers should be ABC dry chemical extinguishers that are appropriate for use with materials normally encountered on a tub grinder.

If a fire does start, CALL THE LOCAL FIRE DEPARTMENT IMMEDIATELY. Then, use the fire extinguisher if you feel confident that you can extinguish the fire. A 10# extinguisher will last about 15-20 seconds and a 20# extinguisher will last about 20-24 seconds, so they will not stop a large fire. The fire extinguishers should be at least 10#, but the preferred are 20#.

**When using a fire extinguisher, use the P A S S method:**

- Approach the fire with the wind at your back.
- Pull the pin,
- Aim the spout,
- Squeeze the trigger, and
- Sweep along the base of the fire from about 6-8 feet away.

Read the label on your extinguisher now, most extinguishers have descriptions of this method, and an estimated working time.

If an extinguisher is only partially used, the dry chemical will jam in the seals, allowing the extinguisher to lose its pressure charge in less than an hour, making it useless to you. It must be recharged before placing it back on the machine. Have the extinguisher recharged today; a fire will not wait for you to recharge your extinguisher tomorrow!

Fire extinguishers should be inspected and recharged by a professional at least annually to keep them at optimum performance! A “verification of service” collar that confirms the month and year of service should be attached to the neck of the container to confirm when the extinguisher was last serviced.

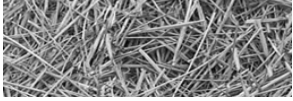


## 1.10 Towing



**CAUTION: DO NOT TRANSPORT THE H-1130 TUB GRINDER** without first securing the conveyor in the transport position (see 2.6.1, page 30).

1. Be sure all loose parts are securely fastened down.
2. Make sure all bystanders are clear.
3. Hitch H-1130 Tub Grinder to a tow vehicle with adequate load carrying and braking capacity. Be sure to attach safety chains between tow vehicle and H-1130 Tub Grinder. Tongue weight is 1,900 lbs. (862 kg).
4. Pull PTO apart and attach to transport bracket on the right hand side of the grinder.
5. Ensure that hitch jack is stored in the up position.
6. Check the turning clearance between H-1130 Tub Grinder and the towing vehicle.
7. Connect H-1130 light harness to the towing vehicle.
8. Check local ordinances regarding restrictions for H-1130 Tub Grinder travel on your planned route.
9. Be aware of machine width at all times and do not exceed 20 miles per hour.
10. Check your state laws regarding the use of lights, slow moving vehicle signs, and other possible requirements.
11. Use good judgment and drive carefully, especially over rough and uneven roads.



## 1.11 Service and maintenance



**WARNING:** Before performing any maintenance on the machine or getting into the tub, be sure rotor and all moving parts have come to a complete stop. Shut off engine and remove the key.

Before working on or near the Tub Grinder or any reason such as servicing, inspecting or unclogging the machine:

- Follow the normal shutdown procedure found on page 28 of this manual.
- If the unit is still attached to a towing vehicle, place the towing vehicle's transmission in park and set the parking/emergency brake.
- Relieve all pressure in the hydraulic system before disconnecting hydraulic lines or performing work on the system. Make sure all connections are tight and the hoses and lines are in good condition before applying pressure to the system.



**WARNING:** Hydraulic fluid escaping under pressure can be invisible and have enough force to penetrate the skin. When searching for a suspected leak, use a piece of wood or a cardboard rather than your hands. If injured, seek medical attention immediately to prevent serious infection or reaction.

- If performing maintenance or servicing which requires the tub to be tilted up, make sure that the tub cylinder stop is in place on the tub tilt cylinder before you begin. For more information, see sections 2.2.9 and 2.7.

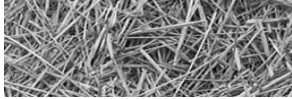


**WARNING:** For your protection **ALWAYS** install the tub cylinder stop on the tub tilt cylinder when the tub is tilted. **NEVER** engage tractor PTO when the tub is raised.



**WARNING:** FAILURE TO COMPLY WITH SAFETY INSTRUCTIONS THAT FOLLOW WITHIN THIS MANUAL COULD RESULT IN SEVERE PERSONAL INJURY OR DEATH. BEFORE ATTEMPTING TO OPERATE THIS MACHINE, CAREFULLY READ ALL INSTRUCTIONS CONTAINED WITHIN THIS MANUAL. ALSO READ THE INSTRUCTION MANUAL PROVIDED WITH YOUR TRACTOR.

**THIS MACHINE IS NOT TO BE USED FOR ANY PURPOSE OTHER THAN THOSE EXPLAINED IN THE OPERATOR'S MANUAL, ADVERTISING LITERATURE OR OTHER DURATECH INDUSTRIES WRITTEN MATERIAL PERTAINING TO THE H-1130 TUB GRINDER.**



## Section 2: Operation

There is no substitute for a sound preventative maintenance program and a well-trained operator.

To insure long life and economical operation, learn how to operate the H-1130 Tub Grinder and how to use the controls properly. Thoroughly instruct the operator in maintenance and operation of the H-1130 Tub.

### GENERAL OPERATING CONDITIONS

#### Operating Temperature

This equipment will operate correctly in its intended ambient, at a minimum between +5°C and +40°C (41°F and 104°F).

#### Relative Humidity

The equipment will operate correctly within an environment at 50% RH, +40°C (104°F). Higher RH may be allowed at lower temperatures.

Measures shall be taken by the Purchaser to avoid the harmful effects of occasional condensation.

#### Altitude

This equipment will operate correctly up to 1000 m (3,280 ft.) above mean sea level.

#### Transportation and Storage

This equipment will withstand, or has been protected against, transportation and storage temperatures of -25°C to +55°C (-13°F to +131°F) and for short periods up to +70°C (+158°F).

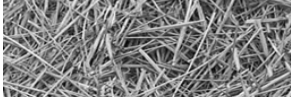
It has been packaged to prevent damage from the effects of normal humidity, vibration and shock.

### 2.1 Pre-Operating Inspection

Prior to the starting the H-1130 Tub Grinder, make a visual inspection of the machine. This can be done when lubricating the machine. Any items that are worn, broken, missing or needing adjustment must be serviced accordingly before operating the H-1130 Tub Grinder.



**WARNING:** Before inspecting the machine, use the normal shutdown procedure found on page 28.



## BEFORE OPERATING CHECKS

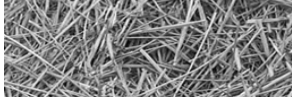
Before operating the H-1130 Tub Grinder, follow these instructions:

- Read and understand the operator's manual.
- Learn how to operate the controls properly. Do Not let anyone operate without instruction.
- Know the machine's safety features and understand the safety precautions.
- Be sure the machine is hitched properly to the tractor.
- Be sure to lubricate all lubrication points. See lubrication chart, page 46.
- Check for loose bolts.
- Make sure machine is properly adjusted.
- Check hydraulic oil level
- Check hydraulic components for leaks or damage.



**WARNING:** Hydraulic fluid escaping under pressure can be almost invisible and can have sufficient force to penetrate the skin. When searching for suspected leaks, use a piece of wood or cardboard rather than your hands. If injured, seek medical attention immediately to prevent serious infection or reaction.

- Visually examine rotor to see if any parts have excessive wear. These parts include shaft, plates, rods, hammers and moveable plate.
- Check screens and screen hold downs for wear and tightness.
- Check installation and condition of hammers.
- Visually examine rotor bearings and mounting bolts.
- Check all bearings for wear.
- Check chains and belts for proper tension and condition.
- Make sure all shields and guards are in place.
- Check condition of decals, replace if excessively worn.
- Check lug nuts for correct tightness. Lug nut should be tightened to a minimum of 120 ft-lbs (17 Kg-M).
- Check condition of tire rims.
- Check tires for proper air pressure. 48 PSI ( 3.3 BAR)
- Always grind with the machine and tractor stationary on level ground.
- In cold weather, allow five minutes for the machine to warm up before grinding.
- Start the machine and check the tub direction, speed control governor for proper operation.
- Watch for unusual or excessive vibration. If any occur, immediately shut off the power. Check to see what is wrong and correct it before starting the grinder again.
- If grinding grain, be sure proper grain attachment is in place.

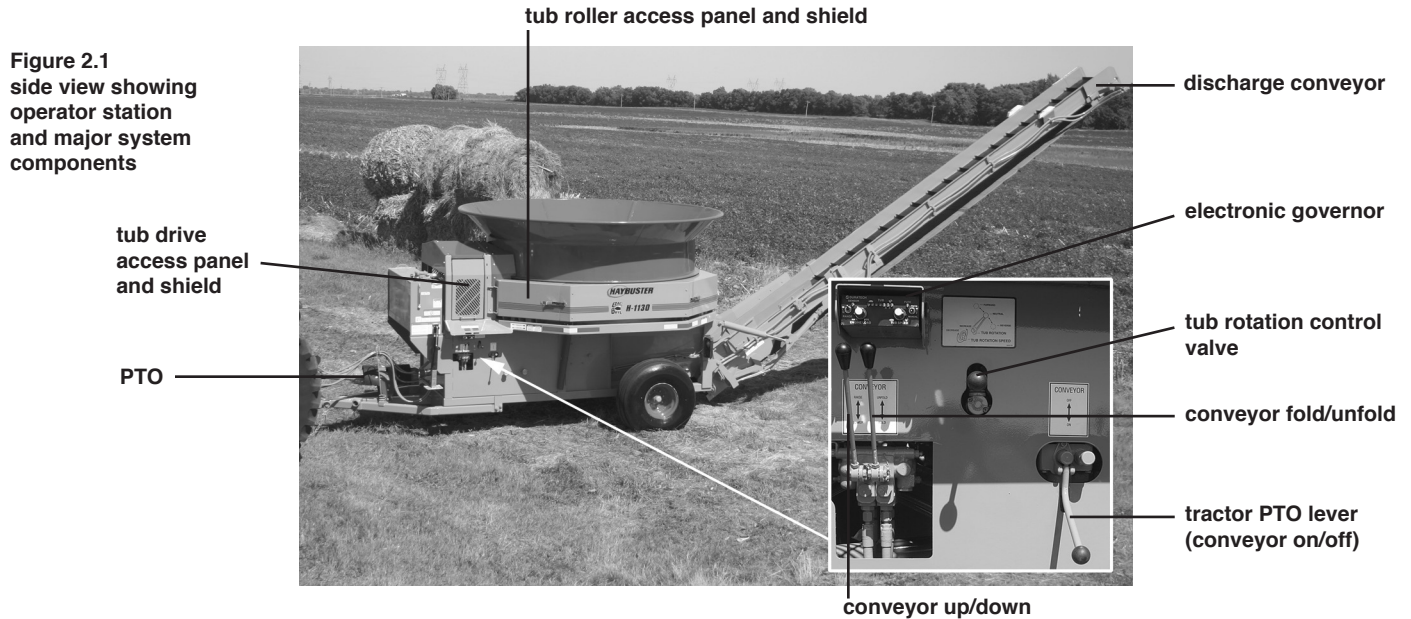


## 2.2 Introduction to the machine

### 2.2.1 Description of the H-1130 Tub Grinder

The Tub Grinder is designed to grind most types of hay, grain and crop residue such as stover and straw. The unit incorporates a number of basic features including the rotating tub, the electronic governor, the rotor and hammer assemblies, the tub chain and drive assemblies, belly auger and discharge conveyor, and the axle and hitch assemblies.

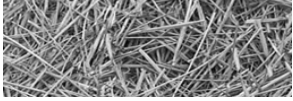
Material is fed into the tub of the unit by appropriate means, such as a wheel loader. As the tub rotates, the material is exposed to the rotating hammers. The hammers then grind the material before the material is discharged by the belly auger and discharge conveyors.



### 2.2.2 Overview of Operator's Controls

Operator controls include:

- **Electronic governor:** The electronic governor regulates tub rotational speed range.
- **Hydraulic valves:** The hydraulic valves control hydraulic oil flow to tub orbit motors. Starts and stops the tub rotation.
- **Conveyor hydraulic controls:** The front lever controls the up/down of the conveyor, and the next lever controls the fold/unfold of the conveyor. One tractor hydraulic circuit is required to power the conveyor hydraulic controls.
- **Tractor engine speed:** The tractor engine speed should be set so 1000 PTO shaft is running at 1000 RPM.
- **Tractor PTO lever:** Engaging the tractor's PTO lever spins the rotor, runs both conveyor belts and powers the tub hydraulic drive. The conveyor must be unfolded to working position before the PTO is engaged.
- **Tub tilt cylinder:** The tub tilt cylinder uses the tractor's second hydraulic circuit to raise and lower the tub platform. Operation of the tub tilt cylinder is performed using the controls for the tractor's second hydraulic circuit which are located on the tractor. Figure 2.1 shows the tub platform in the operating position with the tub platform lowered to the frame.



### 2.2.3 Electronic governor

The Model RCB93 Electronic Governor regulates the speed at which the tub rotates. The electronic governor has two modes of operation, the Engine (Auto) mode and the Tub (Manual) mode. The Engine (Auto) mode is the preferred mode of operation and should be used whenever possible.



**IMPORTANT:** Except when calibrating or trouble shooting the electronic governor always use the Engine (Auto) mode of the electronic governor.

#### Engine (Auto) Mode

When the electronic governor is switched to the Engine (Auto) mode, it is monitoring the rotation speed of the tractor engine. The hydraulic flow to the tub drive mechanism is regulated proportionally to the tractor engine speed. When the engine begins to lug down, the hydraulic oil flow is reduced which in turn slows down the tub rotation. With proper calibration, the engine will only lug down to its optimum horsepower RPM and the tub rotation will be varied proportionally to keep the engine at this RPM. The result is a nearly constant load on the tractor's engine, which will maximize grinding efficiency. **See section 2.10 (pg. 34) for calibration instructions.**

#### Tub (Manual) Mode

In this mode the tub speed is constant and it will not change to match varying load conditions.

### 2.2.4 Rotor

The Rotor and screens are the heart of the tub grinder. The rotor on this H-1130 Tub Grinder is equipped with 88 swinging hammers. Dull edges on the hammers and/or screens will result in a loss of capacity and increased horse power requirements.

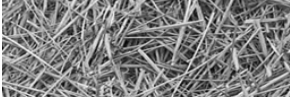


**IMPORTANT:** Hammer and hammer rod life can be extended by keeping the rotor rotating at 2300 RPM. **Excessive tractor horsepower and/or overfeeding the rotor can cause the hammers to lay back resulting in excessive wear on both the hammers and hammer rods.**



**CAUTION:** Keep all foreign objects out of the tub and away from the rotor. Foreign objects may cause personal injury or damage to the H-1130 Tub Grinder.

**CAUTION:** At full speed, energy is stored in the rotor. **Do not use the tractor PTO brake to stop the rotor. Reduce engine speed before disengaging the PTO.**



## 2.2.5 Screens

All H-1130 Tub Grinders require two screens. They come equipped from the factory with a 2” (5 cm) diameter hole screen and a 3” (8 cm) diameter hole screen. Any combination of hole sizes may be used. As a general rule, use the largest diameter screens capable of doing the job.

When using a combination, place the smallest hole diameter on the right hand side of the rotor box where the material enters the rotor.

The size of the hole in the screen determines the coarseness of grind. The larger the hole diameter, the coarser the grind. Hole sizes can vary from 1/8” diameter through 8” diameter. In general, use the larger screen sizes for grinding hay.

As a general guide, DuraTech Industries recommends the following screen sizes:

Hay	2” to 8” (5 cm to 20 cm)
Ear Corn	5/8” to 1” (1.6 cm to 2.5 cm)
Shelled Corn	3/4” (1.9 cm) dry, 5/8” (1.6 cm) high moisture
Small Grains	1/4” (.6 cm) to 3/8” (.9cm)

## 2.2.6 Tub

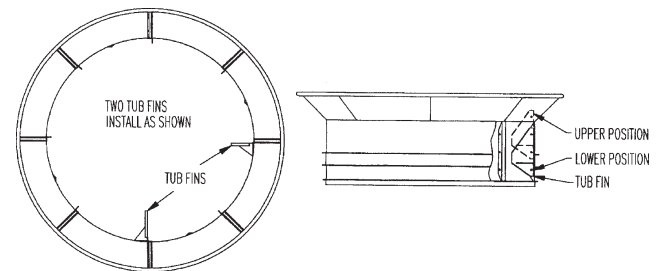
The purpose of the tub is to contain the material above the rotor, and to keep the rotor loaded

### Tub Fins

Two tub fins are furnished with the H-1130 Tub Grinder.

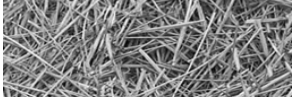
When grinding large round bales, use only one of the tub fins, bolted in the upper position. Two tub fins across from each other may hold the bale up and reduce capacity.

When grinding small round bales, square bales, or loose hay, use two tub fins bolted in the lower position.



## 2.2.7 Slug Buster and Mill Grate

A slug buster or mill grate is installed above the rotor to regulate the amount of material entering the rotor chamber. The standard slug buster is used for ideal grinding conditions (dry hay). The mill grate is used for “less than ideal grinding”, (wet hay or tough grasses).



## 2.2.8 Conveyors, Lifting and Folding

Manual valve on the H-1130 tub grinder controls the conveyor lift and fold. The tractor supplies hydraulic oil for operating the conveyor lift and fold system. Activate the tractor hydraulic circuit before operating the valve on the H-1130 tub grinder.

To correct a reverse flow, either change the hoses around where they connect to the tractor, or reverse the tractor operating lever position. On a tractor with adjustable hydraulic flow rate, adjust the oil flow to a minimum rate and adjust for adequate function speed.

## 2.2.9 Hydraulic Tilt Platform

The H-1130 tub grinder can be tilted 90 degrees for access to the rotor, screens, and drive line. Operation of the tub tilt cylinder is performed using the controls for the tractor's second hydraulic circuit which are located on the tractor. A ball valve (3800906) is connected behind the coupler for safety purposes. The ball valve remains closed (perpendicular) during the machine operation. After using the normal shutdown procedures, the hopper platform can then be opened. The ball valve needs to be open (parallel) for this procedure.

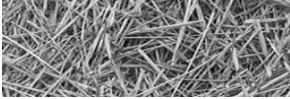


**WARNING:** To prevent serious injury or death, do not tilt platform on unlevel ground or with material in the tub.

**WARNING:** For your protection **ALWAYS** install the tub cylinder stop when the tub is tilted. **NEVER** engage tractor PTO when the tub is raised.



tub cylinder stop



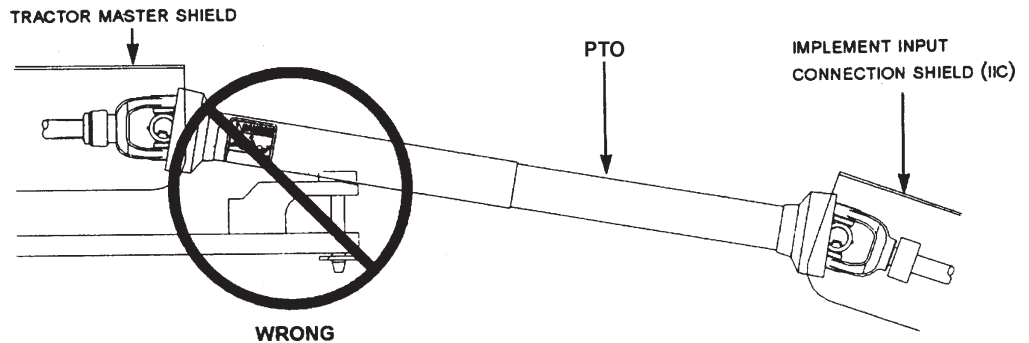
## 2.3 Machine Operation

### 2.3.1 Tractor Set Up

A tractor drawbar and 3-point arms can cause interference with the PTO driveline. This interference can cause serious damage to the PTO guarding and the PTO telescoping members.

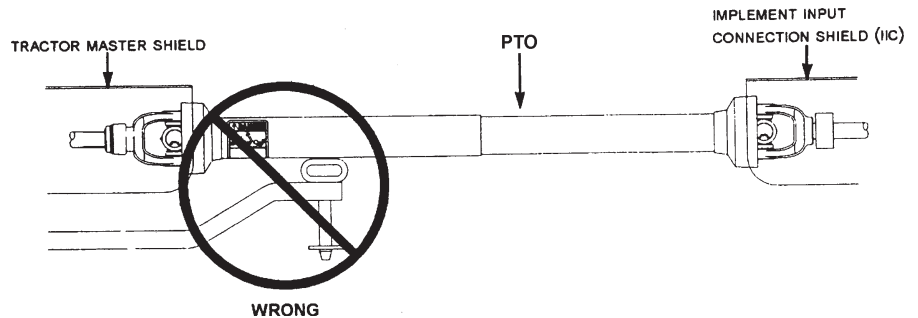
If this implement is attached to a tractor with a clevis hitch (hammer strap) style drawbar, the hammer-strap must be removed to prevent damage to the PTO guarding and the PTO telescoping members. See Figure 2.2.

**Figure 2.2**  
incorrect clevis hitch  
(hammer strap) style  
drawbar set up

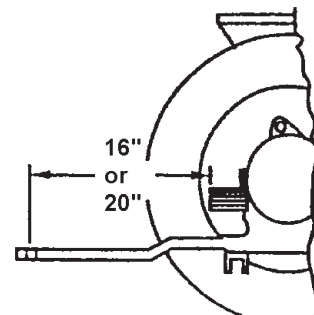


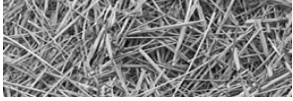
If this implement is attached to a tractor with an offset in the drawbar, be certain it is in the down position to prevent damage to the IID guarding and the IID telescoping members. See Figure 2.3.

**Figure 2.3**  
incorrect offset style  
drawbar set up



If this implement is attached to a tractor with 3-point arms, the arms must be fully raised and locked in position to prevent damage to the PTO guarding and the telescoping members. Adjust the tractor drawbar so the distance from the end of the PTO shaft on the tractor to the center of the drawbar hitch pin hole is 16" (41 cm.) for a 1-3/8" shaft, or 20" (51 cm.) for a 1-3/4" shaft, as shown in the illustration to the right.





### 2.3.2 How to hook up to tractor

To hitch the H-1130 to a tractor, perform the following steps:

1. To reduce wear on the PTO shaft knuckle joints, tractor PTO shaft should be in line (parallel) with the H-1130 Tub Grinder. If tractor is equipped with swinging drawbar, adjust so the tractor PTO and H-1130 Tub grinder drive shaft are in line.
2. Connect hydraulic lines to the tractor.
3. Connect electrical lines to tractor.

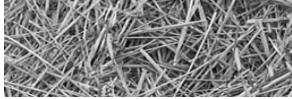


**CAUTION:** To insure a safe hook-up, the H-1130 Tub Grinder and tractor should be connected with a 1” locking pin.

### 2.3.3 How to disconnect from tractor

To disconnect the H-1130 from a tractor, perform the following steps:

1. Park H-1130 Tub Grinder and tractor on a level spot.
2. Lower jack to ground, place blocks under jack if ground is soft.
3. Disconnect electrical wires.
4. Disconnect hydraulic lines.
5. Disconnect PTO, place shaft in shaft holder.
6. Raise hitch of H-1130 Tub Grinder to remove weight from tractor hitch by adjusting jack.
7. Remove hitch pin.
8. Drive tractor away slowly.



## 2.3.4 P.T.O. Shield



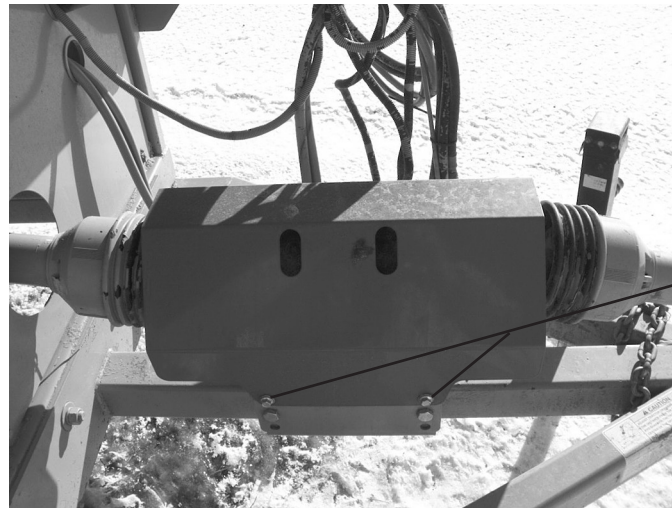
**Warning:** Before lifting the P.T.O. shield be sure to follow the normal shut down procedure. Be certain that the tractor is shut off and all rotating components of the machine have come to a complete stop before lifting shield. Loose clothing is discouraged, and long hair should be restrained whenever working on P.T.O. shafts.

To remove the P.T.O. shield, remove the bolts from the sides of the shield and lift the shield off. If the P.T.O. does not pivot freely look for build up of debris or other obstructions at the pivot point. Do not force the shield, as damage to the shield may occur.

figure 2.4  
Raising the P.T.O.  
shield



**CAUTION! NO STEP! DO NOT STEP OR STAND AT THIS LOCATION**



PTO shield bolts

## 2.3.5 How to operate machine as a unit

### INTRODUCTION

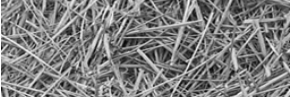
Tractor engines are designed to reach maximum power at PTO speed (1000 rpm), and most tractors are capable of engine speeds from 10 to 20 percent over PTO speed. It will be necessary to operate tractor PTO at approximately 1000 rpm.

The Electronic Governor controls the feed rate to keep the tractor at its peak power point. The operator is able to select the operating range so that when the feed of material lugs down the tractor, the Electronic Governor will reduce the feed at a high enough PTO speed for the tractor to recover automatically if a slug is encountered.

### GRINDING

Place materials to be ground directly into the tub. The best method for filling the H-1130 Tub Grinder is:

1. Engage Rotor and increase speed to 1000 RPM on the PTO shaft
2. Fill the tub about half full of unground materials before starting tub rotation.
3. Start tub.
4. Place additional materials in the tub.



## LOOSE HAY

The best capacity will be obtained if the tub is consistently kept no less than half full of loose hay. When loading the tub, place materials slightly to the front rather than directly over the rotor. For best results feed the tub with small portions.

## WET OR FROZEN HAY

This is the toughest material for any grinder to handle. When filling the tub with wet or frozen hay, deposit small quantities on a more frequent basis rather than filling the tub with one load.

## LARGE ROUND BALES

Place large round bales in the tub on end or on the side. Try grinding bales each way to determine which method will work best for you.



**IMPORTANT:** Never drop a large round bale into the tub from a high level. Ease the bale over the edge and down into the tub carefully. Dropping a large bale directly on top of the rotor will cause damage to the rotor.

## CROP RESIDUE

When grinding crop residues, use the same methods as with loose hay. Extremely wet or frozen materials should be placed sparingly into the tub.

## SMALL GRAINS

Grinding small grains requires special attachments. These attachments fit directly over the rotor. It is not recommended that small grains be ground without the use of one of the small grain attachments. (See Appendix B: H-1130 Specifications under the heading “Options”.)

## EAR CORN

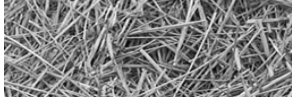
Grinding ear corn requires a special attachment. This attachment fits directly over the rotor and uses crossbars in the tub to feed corncobs into the rotor. (See Appendix B: H-1130 Specifications under the heading “Options”.)

## IF LODGING OCCURS

Materials may lodge against the side of the tub and not feed down to the rotor. If this occurs, reverse the tub direction briefly and then start the tub in a forward direction again. This practice normally dislodges any materials.



**WARNING:** Never attempt to dislodge material inside the rotor when the machine is in operation by physically pushing down on materials. **WHEN THE MACHINE IS IN OPERATION, STAY OUT OF THE TUB.**



## 2.4 Shutdown procedures

### 2.4.1 Normal Shutdown Procedure



**CAUTION:** At full speed, energy is stored in the rotor. **Do not use the tractor PTO brake to stop the rotor.**



**WARNING:** The stored up energy in the rotor causes it to rotate long after disengaging the tractor PTO. Before performing any maintenance on the machine or getting into the tub, be sure rotor and all moving parts have come to a complete stop.

Before working on or near the H-1130 Tub Grinder for any reason, including servicing, inspecting or unclogging machine:

1. Run H-1130 Tub Grinder until discharge conveyor is empty, and grind as much of the material in the tub as possible.
2. Reduce engine speed to idle.
3. Disengage PTO
4. Disengage hydraulics.
5. Place transmission in park and set parking brake.
6. Shut off tractor engine and remove key.
7. Wait for all movement to stop.
8. Disconnect PTO driveline from tractor.

### 2.4.2 Emergency Shutdown Procedure

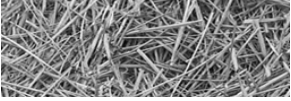
Disengage PTO and tractor hydraulics

## 2.5 Storage

### 2.5.1 Preparing for storage

To prepare the unit for storage, perform the following steps:

1. Check the wheel bearings for lubrication requirements and adjustments at the end of the season.
2. Check the pressure roller bearings for lubrication and adjustments at the end of the season.
3. Clean the machine thoroughly to prevent rust and to make inspections easier. Clean and repaint the tub floor to prevent rust and sticking problems at start up time.
4. Check for loose or worn chains, belts, sprockets, and pulleys.
5. Check the condition of bearings.



## **2.5.2 Removing from storage**

To prepare the unit for use after storage, perform the following steps:

1. Perform a thorough pre-operation inspection.

## **2.6 Road Transport**

### **2.6.1 Set up to transport**

Inspect H-1130 Tub Grinder for any loose parts, tools, or any materials. Remove them or fasten them securely to the H-1130 Tub Grinder.

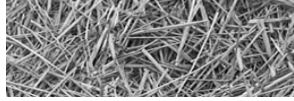
To set up the H-1130 for transport, perform the following steps:

1. Fold the conveyor.
2. Check for local restrictions on towing.

### **2.6.2 Change back to operate**

To set up H-1130 for operation, perform the following steps:

1. Connect H-1130 Tub grinder to tractor.
2. Connect hydraulic hoses and electrical cable to tractor
3. Lower the discharge conveyor.
4. Unfold conveyor to working length.



## 2.7 Raising the Tub Platform



**WARNING:** To prevent serious injury or death, do not tilt platform on unlevel ground or with material in the tub.

To raise the tub platform, perform the following steps:

1. Park machine on firm level ground or surface.
2. Remove all material from tub.
3. Disengage the PTO.
3. Clear personnel from work area.
4. Raise platform.
5. Install tub cylinder stop.



**WARNING:** For your protection **ALWAYS** install the tub cylinder stop when the tub is tilted. **NEVER** engage tractor PTO when the tub is raised.

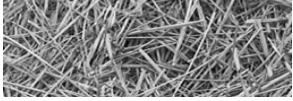
tub cylinder stop in working position  
on tub tilt cylinder

tub cylinder stop lock pin

tub tilt cylinder



tub cylinder stop on storage bracket



## **2.8 Parts of the electronic governor**

### **FUSE LIGHT**

This light is on whenever the electronic governor is receiving power.

### **SENSOR LIGHT**

This light is on whenever the electronic governor is receiving an adequate input signal from the sensor and the rotor is engaged.

### **SPEED LIGHTS**

These lights provide a relative indication of how fast your tub should be turning based on the output signal that the electronic governor is sending to the electro-hydraulic valve.

### **MODE SWITCH**

The mode switch has three possible positions. The off position which turns the electronic governor off and two other positions which correspond to the tub (manual) and engine (auto) modes of operation. In the “tub (manual)” position the tub will rotate at a constant speed based on the settings of the Tub Limit Knob (Tub Speed Knob). The “engine (auto)” position uses all the functions of the Electronic Governor. The maximum tub speed will be limited by the Tub Limit Knob (Tub Speed Knob), and the tractor engine load will be controlled by the Engine Load Knob.

### **TUB SPEED KNOB (TUB LIMIT KNOB)**

This knob sets the maximum speed at which the tub will rotate in both the tub (manual) and engine (auto) modes. In the engine (auto) mode tub speed will vary between zero and this setting depending on the tractor engine load.

### **ENGINE LOAD KNOB**

This knob is used only in engine (auto) mode. It controls the load placed on the tractor’s engine. Turning the knob clockwise decreases engine load, and turning the knob counterclockwise increases the engine load.

### **RANGE SWITCH**

This switch is a coarse adjustment for the engine load knob and can be switched to a H- high, M-medium or L-low setting.

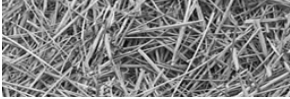
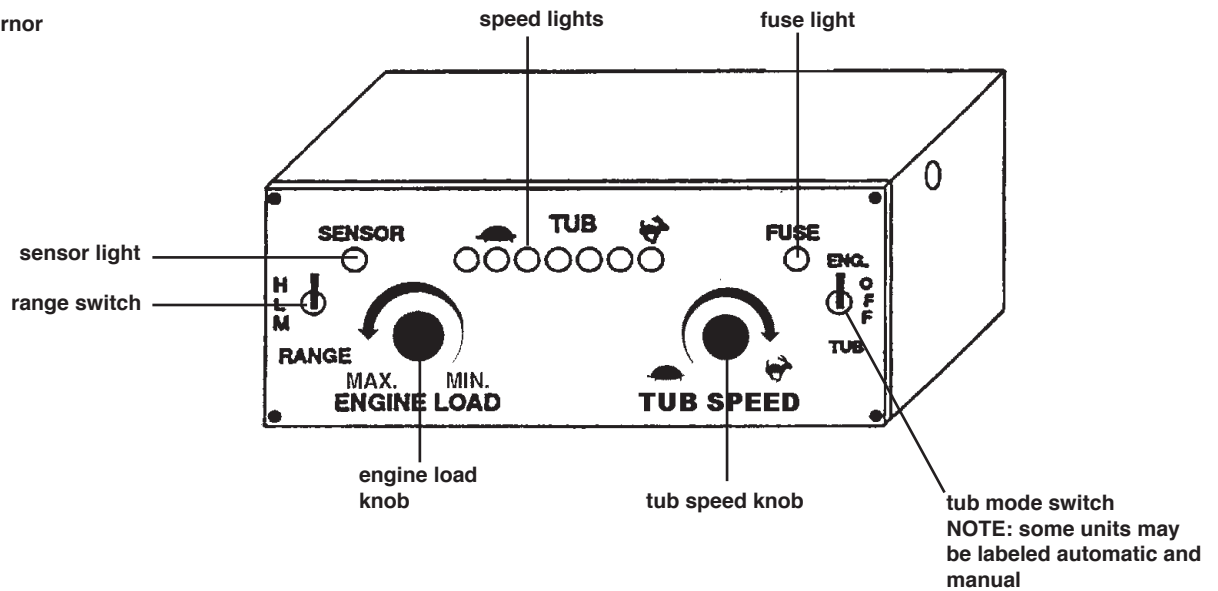


Figure 2.5  
electronic governor  
controls



## 2.9 Operation of the electronic governor

### Engine (Auto) mode



**IMPORTANT:** Except when calibrating or trouble shooting the electronic governor always use the engine (Auto) mode of the electronic governor.

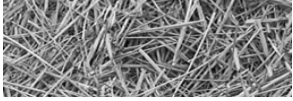
In engine (Auto) mode, the electronic governor monitors the rotation speed of the tractor's engine. The hydraulic flow to the tub drive mechanism is regulated in proportion to the tractor's engine speed. As the engine speed slows, the electronic governor decreases the hydraulic flow which slows down the tub's rotation. Conversely, as the tractor's engine speed increases, the electronic governor increases the hydraulic flow which speeds up the tub's rotation. This allows the electronic governor to automatically control the feed rate keeping the tractor's engine running within the governor's optimum power zone. When the load on the grinding rotor begins to lug the tractor's engine, the governor automatically reduces the tub's rotation speed in proportion to the load. The result is nearly a constant load on the tractor's engine, which maximizes the grinding efficiency.

The range of rotor speeds for which the electronic governor will regulate the hydraulic flow is determined by the setting of the engine load knob. For example, turning the engine load knob counter clockwise will increase the load on the engine by keeping the tub engaged to a lower engine RPM.

With proper calibration, the tractor's engine will only load down to its optimum horsepower RPM, and the tub's rotation speed will be varied proportionally to keep the tractor's engine at this RPM.

### Tub (Manual) mode

In tub (manual) mode, the electronic governor performs as a simple tub speed control. In this mode the tub speed is constant and it will not change to match varying load conditions.



## 2.10 Calibration of the electronic governor

To calibrate the electronic governor, perform the following steps:

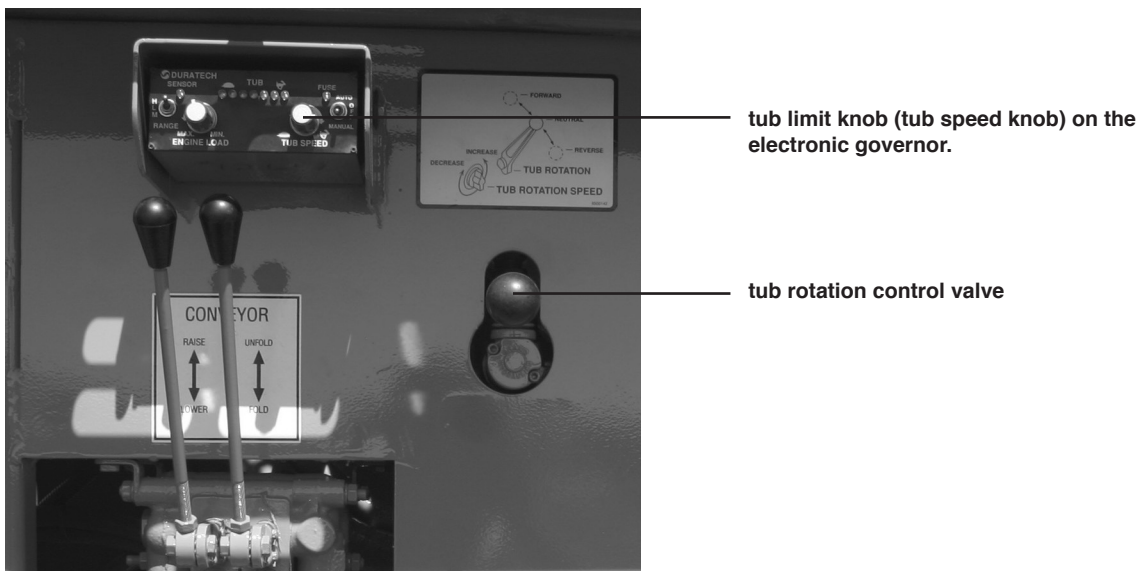
1. Begin calibration procedure with H-1130 Tub Grinder completely shutdown. Place the MODE switch in the OFF position and the RANGE switch in the H-High position. Rotate the TUB LIMIT KNOB fully clockwise toward the rabbit position. Turn the ENGINE LOAD KNOB fully clockwise, and switch the MODE switch to Engine (Auto) Position.
2. Verify that tub rotation lever is in neutral. Inspect machine to verify that all personnel are clear of the machine.
3. Start tractor and run the grinder at about 1/2 throttle to allow the hydraulic system to warm up before calibrating the RCB93 Electronic Governor.
4. When the system has reached operating temperature, throttle the tractor to 1000-1200 engine RPM. Engage the tub drive and throttle up to PTO speed. The FUSE light and the SENSOR light should come on. The tub should not be rotating at this time. If the tub is rotating, read section 5.1 “Troubleshooting the electronic governor system” in this manual.
5. Slowly rotate the ENGINE LOAD KNOB counter-clockwise until the tub just begins to move. The tub should begin to rotate. If it does not begin to rotate, switch the range switch to M-Medium or L-Low and repeat as necessary.

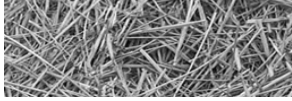
**TEST:** Throttle the tractor’s engine down and the tub should stop rotating, return the tractor’s engine to PTO RPM and the tub should start to rotate.

If the tub will not rotate, read section 4.1 “Troubleshooting the electronic governor system” in this manual.

## 2.11 Adjusting the tub’s rotation speed

Tub rotation is controlled by two components . The tub is started, stopped and reversed by the tub rotation control valve, and the tub’s rotation speed is controlled by the tub limit knob (tub speed knob) on the electronic governor.





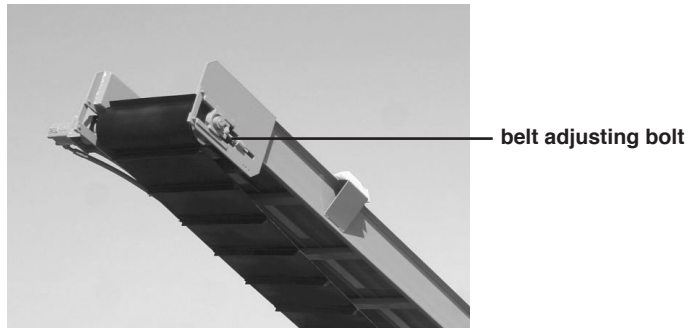
## 2.12 Adjusting the conveyor belt tension

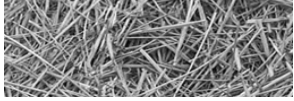
The rollers on the discharge conveyor are adjustable to allow for belt stretching and tracking. If the conveyor belt slows down or stops during operation, slippage may be the cause. To eliminate slippage, tighten the adjusting bolts on the conveyor equally. This will help to keep the belt centered on the rollers.



**IMPORTANT:** Do not overtighten conveyor belts. Use only enough tension to eliminate belt slippage.

Figure 2.6  
discharge conveyor belt  
adjusting bolts





## 2.13 Adjusting the conveyor belt tracking

A. When a new belt is installed: Use only genuine DuraTech Industries parts.

1. Begin by adjusting the drive roller so that the mounting bearings are the same distance from the end of the conveyor frame. This ensures that the roller centerline is square with conveyor frame. Adjust the idler roller tension bolts so that they are equal on both sides of the conveyor.

B. If the belt is running to the right side, perform the following steps:

1. Adjust the idler roller tension bolt on the right side of the conveyor. Increase tension by approximately 2 full turns of the adjusting nut.
2. Make certain that all personnel are clear of machine and the start engine. Engage the tractor PTO.

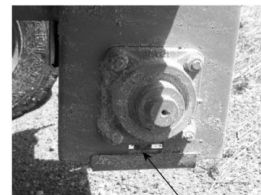


**NOTE:** The rotor will also be turning.

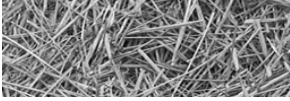
3. Observe conveyor belt tracking from a safe location.
4. If further adjustment is required, disengage tractor PTO, and shut down the machine using the normal shutdown procedure.
5. Some adjustment of the drive roller may be required if no improvement is noted by increasing the idler roller tension.
6. Repeat steps 1-5 until proper tracking is achieved.

C. If the belt is running to the left side, perform the following steps:

1. Adjust the idler roller tension bolt on the left side of the conveyor. Increase the tension by approximately 2 full turns of the adjusting nut.
2. Make certain that all personnel are clear of machine and start engine. Engage the tractor PTO.
3. Observe the tracking of the conveyor belt from a safe location.
4. If further adjustment is required, disengage tractor PTO and shutdown using the normal shutdown procedure.
5. Some adjustment of the drive roller may be required if no improvement is noted by increasing the idler roller tension.
6. Repeat steps 1-5 until proper tracking is achieved.



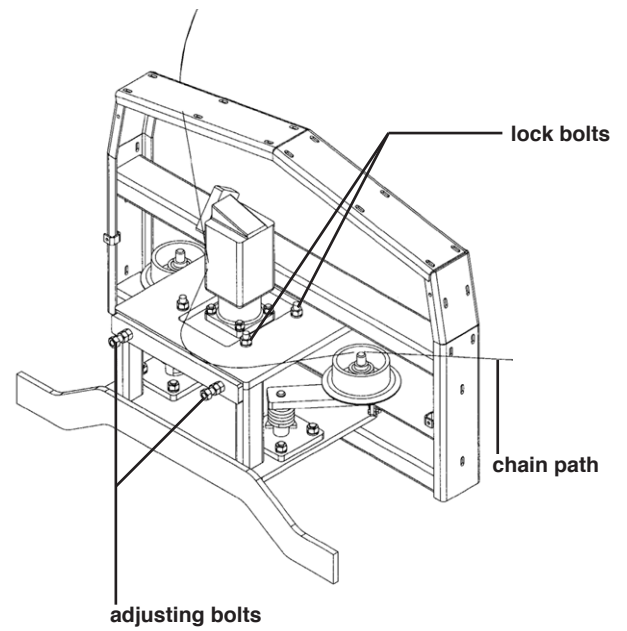
idler roller tension adjusting bolt

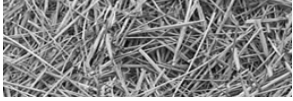


## 2.14 Adjusting tub chain tension

To adjust the tub chain tension, perform the following steps:

1. Loosen (4) bolts holding motor mounting plate.
2. Turn (2) adjusting bolts to set chain tension.
3. Tighten the (4)bolts holding motor mounting plate.





## 2.15 Main drive belt adjustment

Power is transferred from the drive shaft to the rotor through drive belts and two sheaves. Maintaining the proper tension on these belts is critical for reaching optimum grinder performance. A spring tensioning system is used on the H-1130 grinder to maintain tension as belts stretch over time. To properly tension the drive belts turn the tensioning rod until the spring caps come into contact with the tubes that the springs are seated into. **DO NOT OVERTIGHTEN!**

The two sheaves must be running parallel, if they are not the belts will not track, premature belt wear or belts running off of the sheaves will result. Adjust sheave alignment if needed.

### Discharge Conveyor Flow Control Valve

A flow control valve is located on the side of the discharge conveyor. This valve allows the operator to control the speed of the discharge conveyor; it will not vary the speed of the belly augers.

### Adjusting the discharge conveyor flow control valve

The discharge conveyor flow control valve can be used to slow the discharge conveyor down which is helpful when grinding in windy conditions, when loading trucks, or when the grinder output is low. The flow to the hydraulic motor can be varied from approximately zero to the maximum flow by adjusting the valve from min (0) to max setting (10).



**Note:** Whenever this valve is used to decrease the speed of the discharge conveyor, heat will be generated. The hydraulic system may not be able to dissipate the excess heat generated in warm operating conditions. Always be aware of the hydraulic oil temperature; a thermometer is located on the side of the hydraulic reservoir. If the oil temperature becomes greater than 175°F (79°C) adjust the valve to max setting (10).

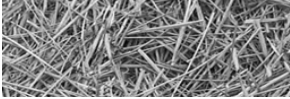
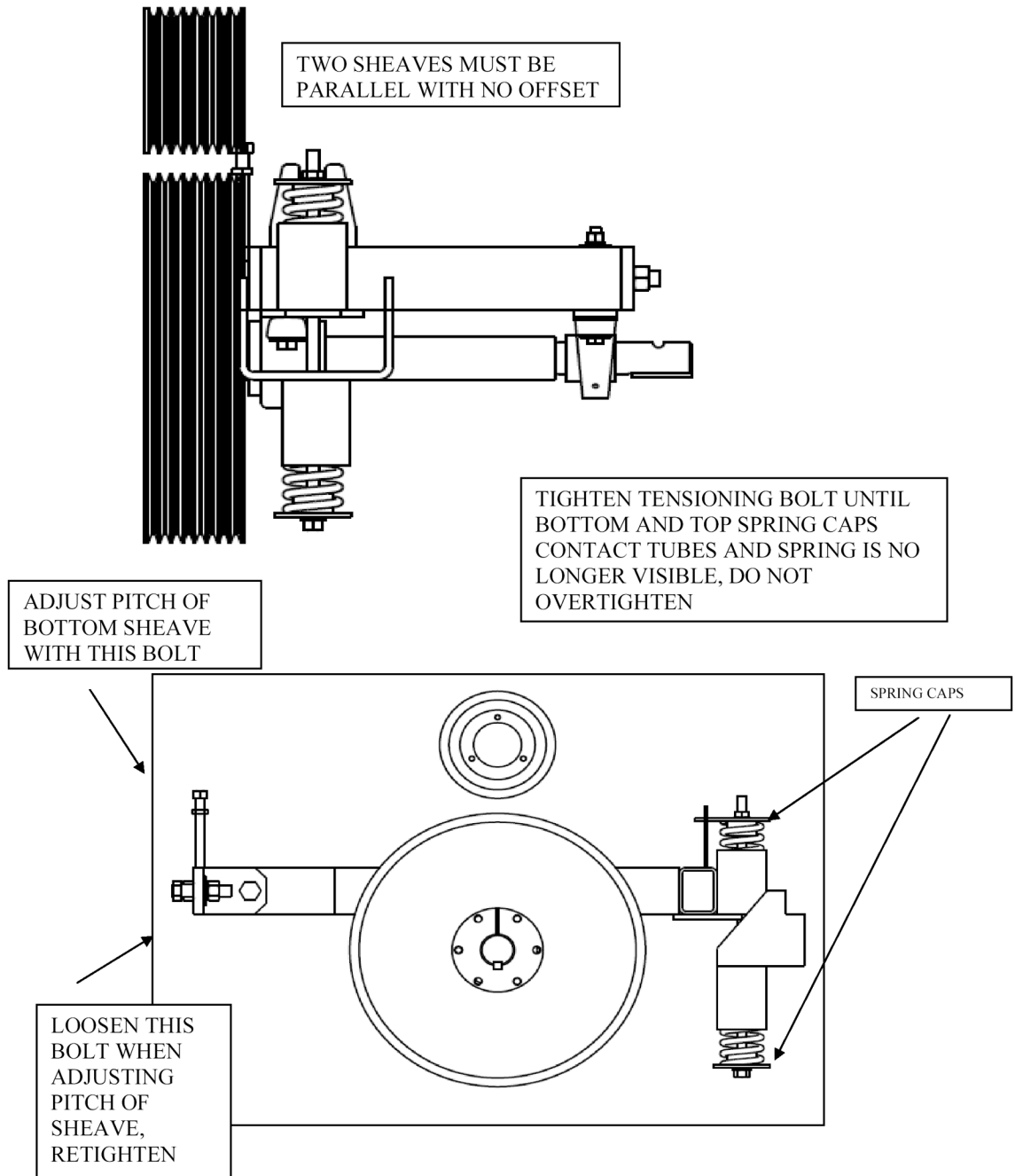
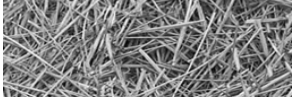


Figure 2.7  
sheave alignment





## 2.16 Electro-hydraulic valve coil test

See the figure 2.9 for the location of the electro-hydraulic valve coil.

This test requires an accurate ohm meter. Disconnect the wiring harness leads at the electro-hydraulic valve coil. Check resistance of valve coil leads at the terminals. The resistance should be between 8 to 10 ohms. If the values are not within this range, replace the electro-hydraulic valve coil.

### MANUAL OVERRIDE

NOTE: If there is an electrical failure with the machine, it may still be able to grind. Switch the electronic governor off. Remove the acorn nut and loosen the jam nut on the electro-hydraulic valve. Start the machine and engage the tub drive.

figure 2.8  
electronic governor system

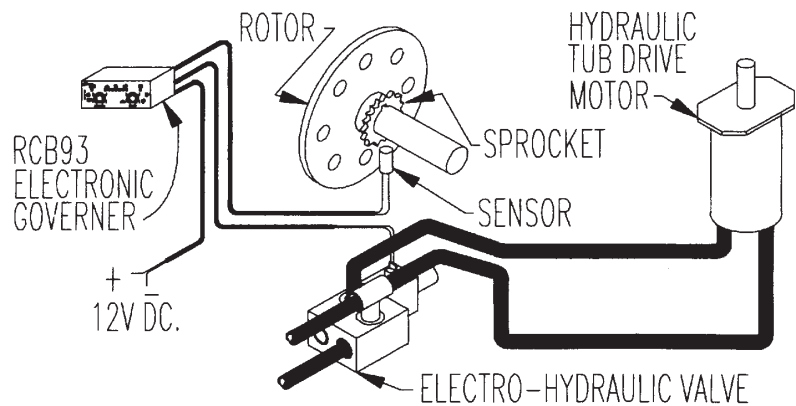
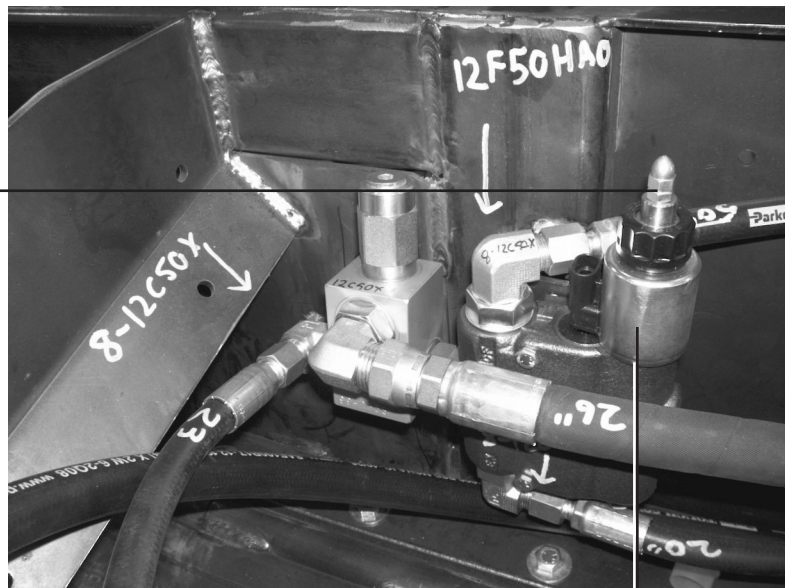
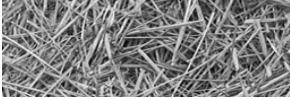


figure 2.9  
location of the  
electro-hydraulic  
valve

location of acorn nut and jam nut found  
under rubber cap end



electro-hydraulic  
valve



Turn the adjusting stud clockwise until the tub rotates at the desired speed. Lock the jam nut on the adjusting stud and replace the acorn nut on the electro-hydraulic valve. When the electro-hydraulic valve is adjusted in this manner, it will function only as a manual flow control. The grinder will now operate as it would if the electronic governor were switched to the tub (manual) mode. The tub speed will be constant and it will not change to match varying load conditions.

Contact your dealer for repairs or replacement parts. When the problems are corrected, calibrate the electro-hydraulic valve as described in the next section.

## 2.16a Sensor test

Set the gap between the sensor and the sprocket to  $3/32$ " (2.4 mm). Sensor resistance should be 900 ohms +/- 10%.

## 2.17 Electro-hydraulic valve calibration

DuraTech Industries International Inc. test runs every grinder before it leaves the factory. The electronic governor system was calibrated at this time and should not need any further adjustment. Before attempting to adjust the electro-hydraulic valve, follow the instructions below.

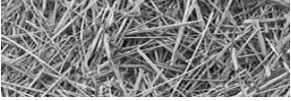


**NOTE:** With the electronic governor switched to tub (manual) mode, the tub will continue to rotate regardless of the engine RPM.

1. When first starting the machine, run at less than full throttle to allow the hydraulic system to warm up before operating.
2. With engine running at full throttle, turn the engine load knob clockwise to maximum position and set the mode switch in the engine (auto) position. Engage the tub using the tub control lever. Check the sensor light on the electronic governor before doing any adjusting! At this point, the sensor light should be lit. If the sensor light is not lit, read section 5.1 "Troubleshooting the electronic governor system" in this manual.



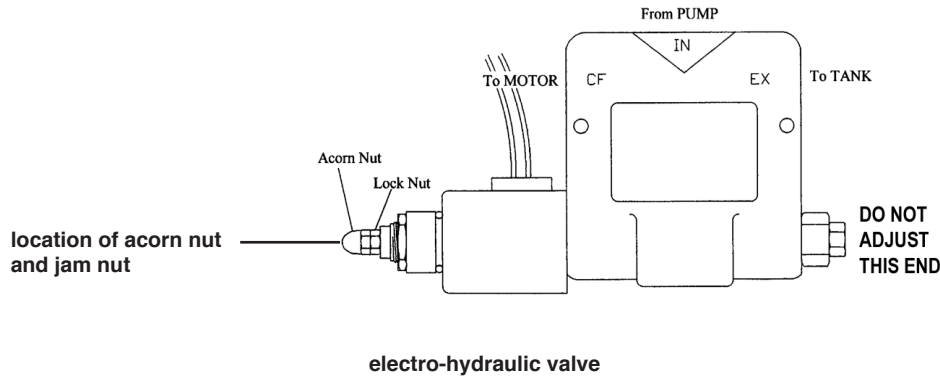
**NOTE:** Turning the engine knob clockwise will decrease the load on the engine by disengaging the tub at a higher engine RPM.



3. If tub is not turning, you are ready to proceed to the grinding section of this book. Remember the engine load knob adjusts the load placed on the engine, and under normal conditions this will be the only adjustment you will have to make.

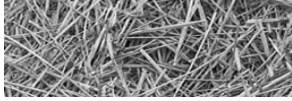


**IMPORTANT:** Stay clear of all moving parts while calibrating the electro-hydraulic valve. **The tub will be rotating during this adjustment.**



To calibrate the electro-hydraulic valve coil after following the three steps above, perform the following steps:

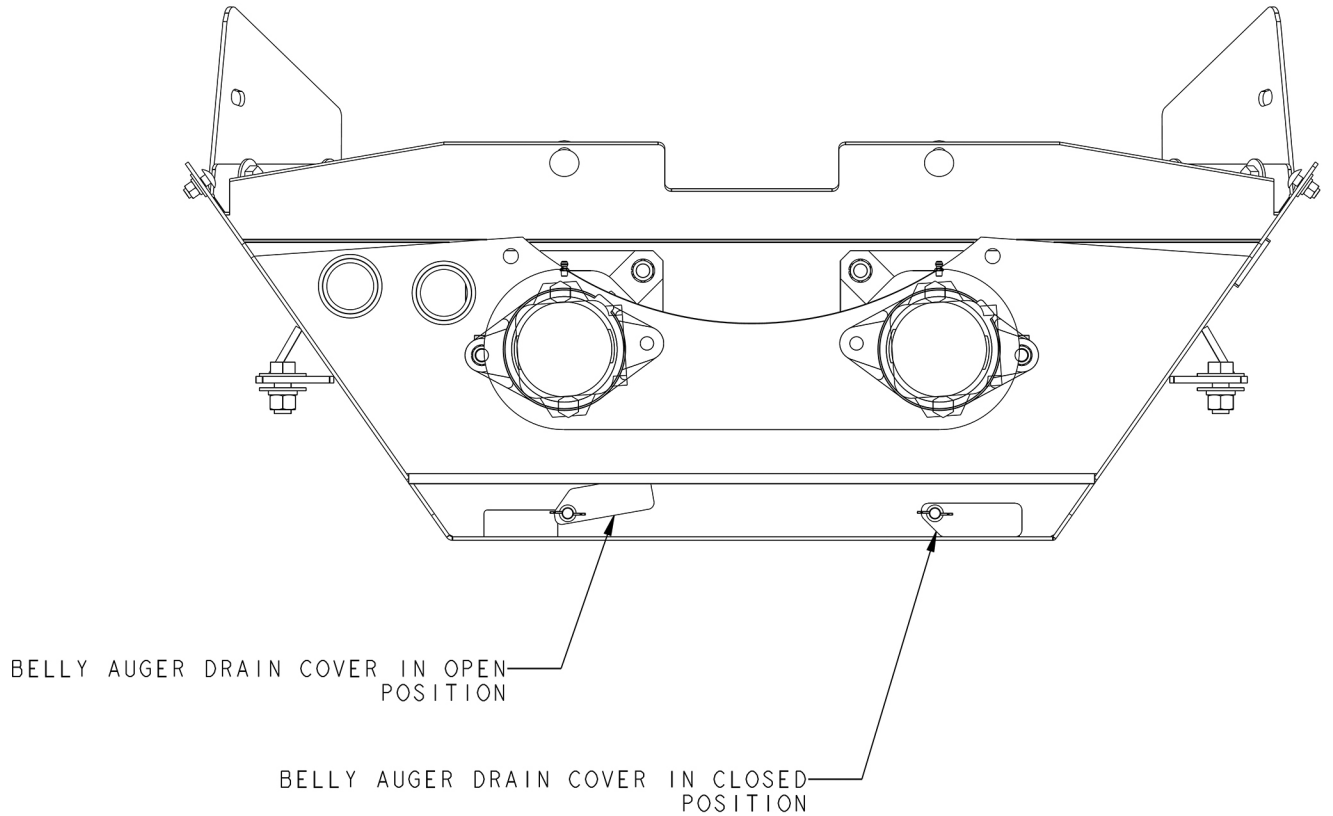
1. Shut down the machine using the normal shutdown procedure in this manual
2. Disconnect the wiring harness from the electro-hydraulic valve coil.
3. Remove the acorn nut from the end of the electro-hydraulic valve. This will reveal a jam nut and an adjusting stud with a screwdriver slot.
4. Loosen the jam nut.
5. Turn the adjusting screw counterclockwise until it stops.
6. Lock the adjusting screw with the jam nut and replace the acorn nut. Reconnect the wiring harness to the electro-hydraulic valve coil.

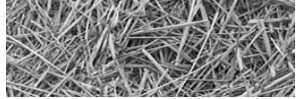


## 2.18 Belly auger drain covers

Belly auger drain covers should be in the open position to allow any moisture to drain out.

When grinding small grains the belly auger covers should be in the closed position to keep the grain from spilling out.





## Section 3: General Maintenance

### SERVICE AND MAINTENANCE



**CAUTION:** If for any reason arc welding is to be done, always ground cylinder to frame of machine to prevent arcing in bearings.

1. Before working on or near the H-1130 Tub Grinder for any reason, including servicing, inspecting or unclogging machine:
  - a. Run H-1130 Tub Grinder until discharge conveyor is empty, and grind as much of the material in the tub as possible.
  - b. Reduce engine speed to idle.
  - c. Disengage PTO
  - d. Disengage hydraulics.
  - e. Place transmission in park and set parking brake.
  - f. Shut off tractor engine and remove key.
  - g. Wait for all movement to stop.
  - h. Disconnect PTO driveline from tractor.
2. When replacing any part on your H-1130 Tub Grinder, be sure to use only DuraTech Industries authorized parts.
3. Relieve all pressure in the hydraulic system before disconnecting the lines or performing other work on the system. Make sure all connections are tight and the hoses and lines are in good condition before applying pressure to the system.

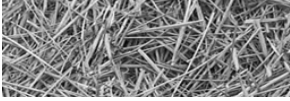


**WARNING:** Hydraulic fluid escaping under pressure can be invisible and have enough force to penetrate the skin. When searching for a suspect leak, use a piece of wood or cardboard rather than your hands. If injured, seek medical attention immediately to prevent serious infection or reaction.

4. Visually examine to see if any internal parts show excessive wear. Repair or replace needed parts. These parts include rotor plates and holes in the plates that support the rods. Enlarged holes can cause rods to break.

Also check rods, rod locking and retaining devices, hammers, screens, screen tracks and hold downs, main shaft, hinges or anything else that could wear and perhaps fail if not properly maintained, and cause damage to the rotor and/or personnel safety. Check bearing alignment and mounting bolts to insure a firm foundation and reduced vibration.

Keep all foreign objects out of the tub and away from the rotor. Foreign objects may result in personal injury or cause severe damage to hammers, screens, rods, and other parts that will cause rotor failure.



5. Check for loose or worn chains, belts, sprockets and pulleys.
6. Keep sprockets and pulleys aligned.
7. Inspect rotor and all rotating parts for wrapped twine or wire build up.
8. If machine is going to sit idle for an extended period of time, tub floor should be cleaned to prevent rust and sticking problems at start up time.
9. The proper tire pressure is 48 PSI (3.3 BAR).
10. The wheel bearings should be checked for lubrication and adjustments yearly, preferably at the end of the season.

If a generous amount of grease is on the bearing and in the housing, and if the grease is soft, the grease will not need changing.

If the lubricant is caked and the bearing seems dry, wash the bearing to remove old grease. Repack the bearing.

### 3.1 Lubrication



**CAUTION:** Follow normal shutdown procedure before adjusting or lubricating.

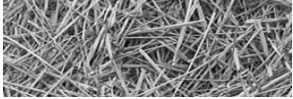
When operating the H-1130 Tub Grinder during cold weather, perform all lubrication after bearings are at operating temperatures.

#### BEARING LUBRICATION

Bearings operating in the presence of dust and water should contain as much grease as speed will permit, since a full bearing with a slight leakage is the best protection against entrance of foreign material. In the higher speed ranges, too much grease will cause overheating.

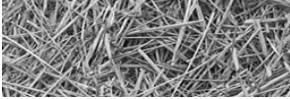
High-speed operation, abnormal bearing temperature may indicate faulty lubrication. Normal temperature may range from “cool to warm to the touch” up to a point. Unusually high temperatures “too hot to touch for more than a few seconds” accompanied by excessive leakage of grease indicates too much grease. High temperatures with no grease showing at the seals, particularly if the bearing seems noisy, usually indicate too little grease. Normal temperature and a slight showing of grease at the seals indicate proper lubrication.

The following chart is a general guide for relubrication. Certain conditions may require a change of lubrication periods as dictated by experience.

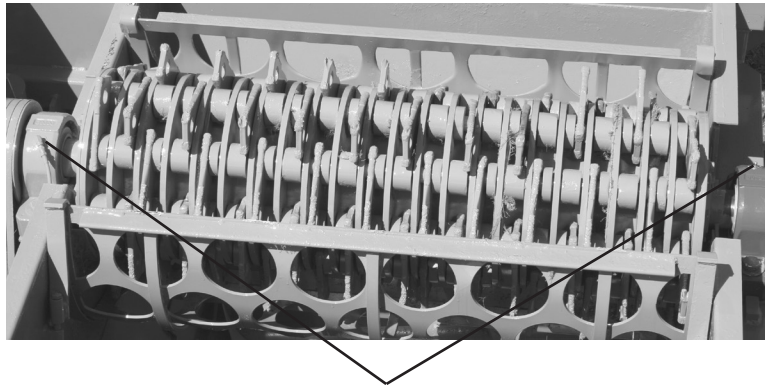


## Lubrication Chart

REF. NO.	LOCATION	NUMBER OF GREASE FITTINGS	FREQUENCY	
1	Jack Shaft Bearings	2	10 hrs.	*
2	Tub Chain Idler Pivot	2	Daily	
3	Rotor Bearings	2	10 hrs.	*
4	Tub Pivot	2	40 hrs.	*
5	Belly Auger Bearings	4	10 hrs.	*
6	Bull Wheel	2	10 hrs.	
7	Discharge Conveyor Bearings	4	40 hrs.	*
8	Discharge Conveyor Lift Pivot	2	40 hrs.	
9	PTO	2	100 hrs	
10	Wheel Bearings	-	Annually	
11	Tub Pressure Roller	-	Sealed	
12	Roller Chains	-	Oil Daily in Dusty Conditions	



**Figure 3.1**  
both rotor bearing  
lubrication points



**rotor bearing lubrication points**  
(Ref # 3)

**Figure 3.2**  
belly auger bearing  
lubrication points



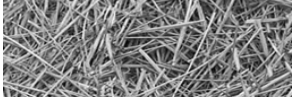
**front rotor bearing lubrication points 1 of 2 (Ref # 3)**

**bull wheel bearing lubrication  
points 2 of 2 (Ref # 6)**

**Figure 3.3**  
tub chain idler pivot  
lubrication point



**tub chain idler pivot  
lubrication point**  
(Ref #2)



**Figure 3.4**  
belly auger bearing  
lubrication points



belly auger bearing lubrication points (Ref #5)

**Figure 3.5**  
tub pivot lubrication points



tub pivot lubrication points (Ref #4)

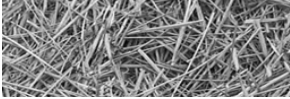
**Figure 3.6**  
tub roller, tub pressure  
roller and roller chain

pressure roller

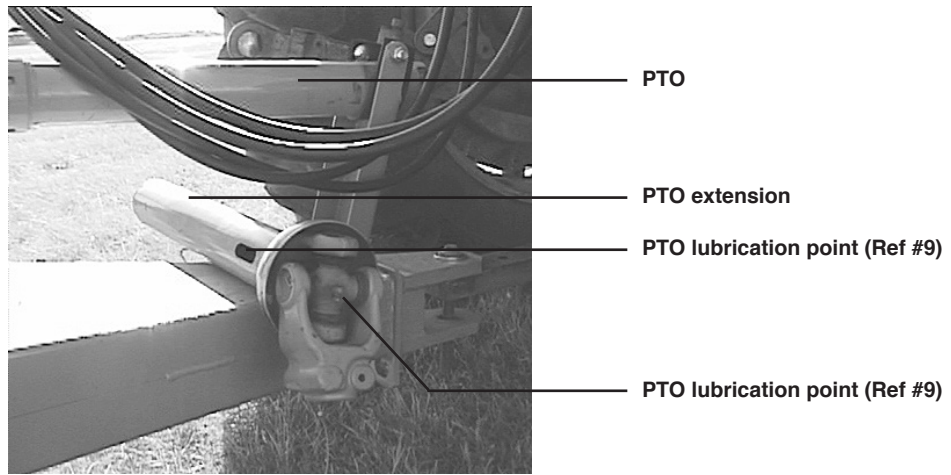
roller chain  
(Ref #12)

tub pressure roller  
(Ref #11)

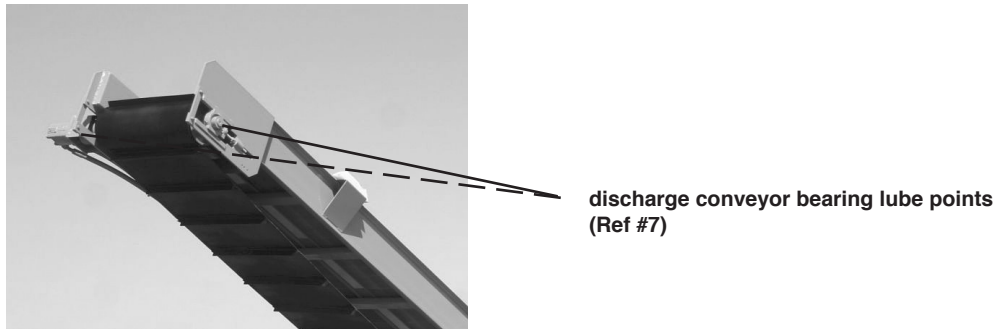




**Figure 3.7**  
two of three PTO lubrication points



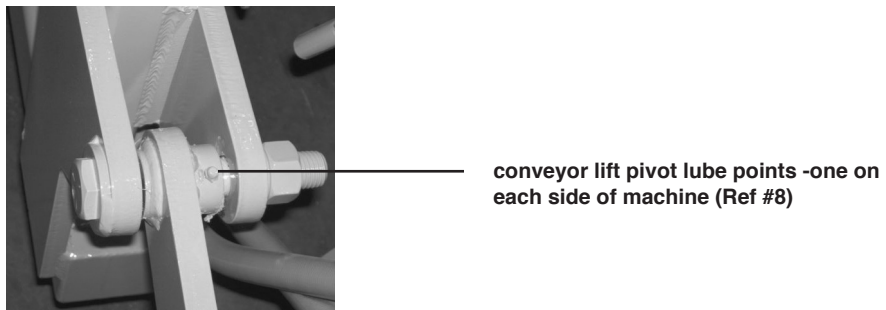
**Figure 3.8**  
discharge conveyor bearings (2 of 4)

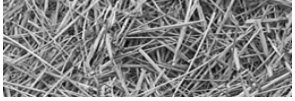


**Figure 3.9**  
discharge conveyor bearings lubrication points (2 of 4)

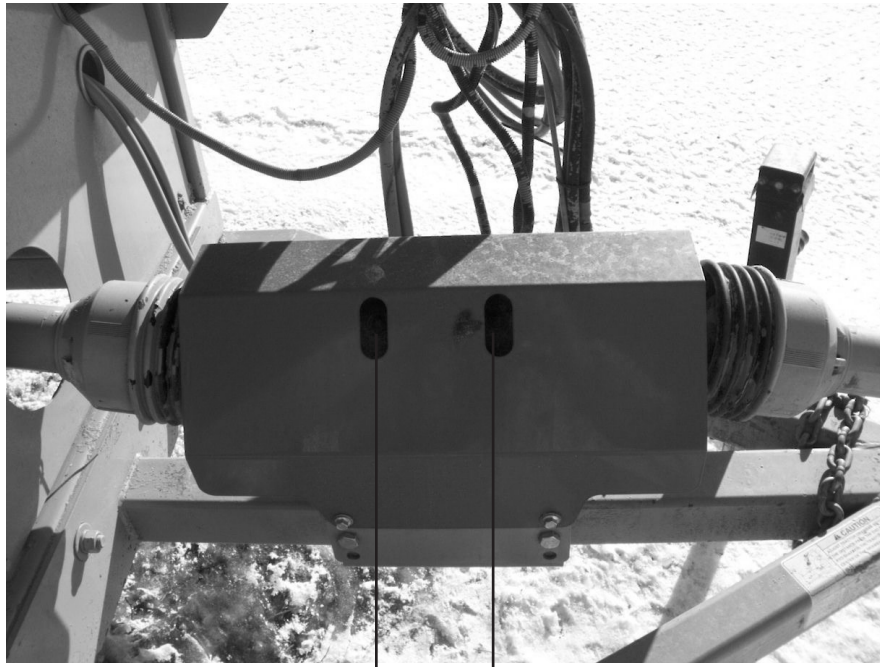


**Figure 3.10**  
conveyor lift pivot lubrication points

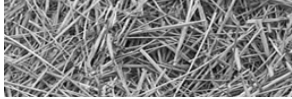




**Figure 3.11**  
**jack shaft bearings**  
**lubrication points**  
**(2 of 2)**



**jack shaft bearings**  
**lubrication points**  
**(Ref #1)**



### 3.2 Hydraulic system



**CAUTION:** Lack of proper oil level in the reservoir tank will cause system to heat under continuous running. Check the hydraulic oil level daily and replace as necessary.

Hydraulic Oil Reservoir Capacity: 60 gallons

All machines have been pre-run at the factory to insure all functions are performing correctly. The hydraulic reservoir contain approximately 60 gallons of hydraulic oil.

The in tank hydraulic oil filters should be changed after the first 10 hours of operation. Change hydraulic oil and filters after the first 100 hours of operation. Thereafter, change hydraulic oil filters every 500 hours and change hydraulic oil and filters at least every 1000 hours of operation. Change the in tank oil filter if the oil filter pressure gauge indicates a plugged filter

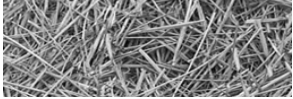
Check the hydraulic oil regularly, and if the oil has a burnt smell or milky appearance, change it immediately.



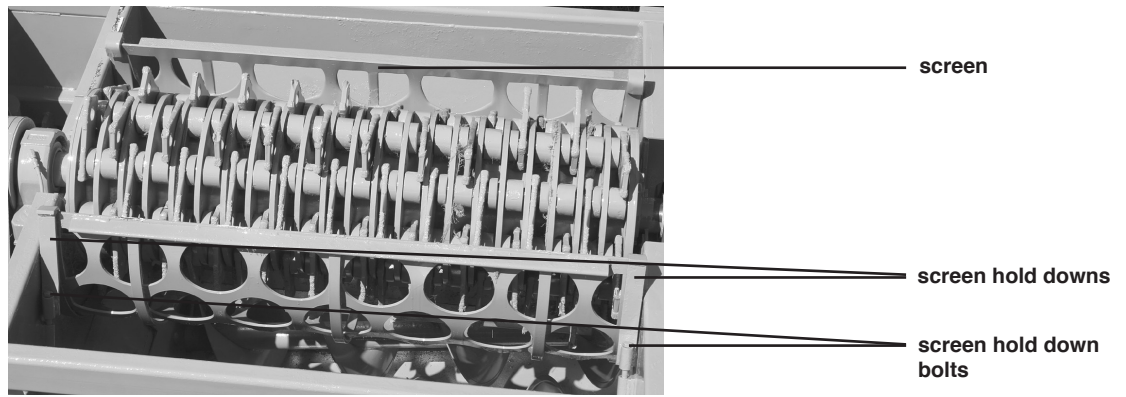
- oil filter pressure gauge
- hydraulic oil fill cap
- hydraulic reservoir
- hydraulic oil level indicator
- hydraulic oil temperature gauge



DuraTech Industries recommends using Cenex Qwicklift HTB if your machine has a Qwicklift decal on the hydraulic tank. Other acceptable fluids include Mobil 423, Farmland Super HTB, Conoco Hydroclear Power Tran Fluid, or other similar fluids. If the hydraulic tank does not have a decal, then all the above fluids are acceptable.



### 3.3 Screens



#### CHANGING SCREENS



**CAUTION:** Keep all foreign objects out of the tub and away from the rotor. Foreign objects may cause personal injury or damage to the machine.

**CAUTION:** Follow normal shutdown procedure before entering tub to do any service work.

To change screens on the H-1130, perform the following steps:

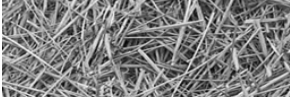
1. Raise the tub platform using the following steps



**WARNING:** To prevent serious injury or death, do not tilt platform on unlevel ground or with material in the tub.

**WARNING:** For your protection **ALWAYS** install the tub cylinder stop or tub prop when the tub is tilted. **NEVER** engage tractor PTO when the tub is raised.

- a. Park machine on level ground or surface.
  - b. Remove all material from tub.
  - c. Clear personnel from work area.
  - e. Raise platform.
  - f. Install tub cylinder stop.
2. Loosen and remove bolts on the screen hold down.
  3. With a large hook or bar, pull the screen from its chamber.
  4. Make sure material is clear from screen track.
  5. Install the new screen.
  6. Replace the screen hold down, and bolts.
  7. Tighten all bolts securely.



### 3.4 Hammermill maintenance

Visually examine the mill to see if any of the internal parts show excessive wear. These parts should include rotor discs and the holes in the discs that support the rods. Enlarged holes can cause rods to break or bend. Also check rods, rod locking or retaining devices, hammers, screens, screen tracks and hold downs, main shaft, platform locking devices, hinges or anything else that could wear and perhaps fail and causing damage to the hammermill and/or personnel safety if not properly maintained. The bearings should also be checked along with mounting bolts to insure a firm foundation and reduced vibration.



**CAUTION:** Keep all foreign objects out of the tub and away from the mill. Foreign objects may result in personal injury or damage to the machine.

The hammers have been designed and manufactured to provide the best compromise between hardness for good wearing qualities and strength for dependability and resistance to breakage.



**WARNING:** The hammers have been heat treated, and any alteration of the hammers by heating, grinding, resurfacing or any other process can change the mechanical properties of the hammer and make it unsuitable or dangerous to use.

Because of the high capacity of the machine, the hammers will wear and must be considered expendable. Each hammer has four cutting edges. For maximum life, it is suggested that hammers be rotated periodically to even out the wear over the entire rotor. If one end of a hammer is allowed to wear too long, one of the hammer's cutting edges will be lost.

Screens also have two cutting edges. When cutting edges become rounded, the screen can be turned end for end exposing the new cutting edges. The results of badly worn hammers and screens is loss of capacity, and added horse power requirements.

Hammer rods are case hardened to maximize wearability and toughness, although hammer rods must be considered expendable.



**NOTE:** Hammer and hammer rod life can be extended by keeping rotor rotating at 2300 RPM. Over powering or over feeding the rotor will cause the swinging hammers to lay back resulting in excessive wear on both the hammers and the rods.



### 3.5 Balanced Hammer maintenance and replacement

## IMPORTANT SAFETY INSTRUCTIONS

*Please Read All Instructions*

**CAUTION!... Turn off and Lockout** the power source to your hammermill, before servicing the equipment.

JACOBS hammers have been designed and manufactured to provide the best compromise between hardness for good wearing qualities and strength for dependability and resistance to breakage. Any alteration of the hammer by heating, grinding, resurfacing or any other process can change the mechanical properties of the hammer and make it unsuitable or dangerous to use. Alteration will void any consideration for possible warranty.

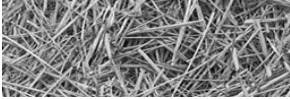
**JACOBS hammers are designed to grind the normal ingredients** used in the manufacture of feed and related products. Other products that may be reduced in size include such products as paper, wood residue, chips, sawdust, shavings or hogged material. **JACOBS hammers are not designed to grind or crush**, on a primary basis, hard materials such as coal or minerals. Metal, rocks or other similar materials can cause hammer failure and should never be allowed to enter a hammermill.

**Visually examine mill to see if any internal parts show excessive wear.** Repair or replace needed parts. These parts should include body, liner, rotor discs and holes in the discs that support the rods. Enlarged or elongated holes in the rotor discs can cause rods to break. Damage to the hammermill and/or personnel can result if rods, rod lock devices, hinges, or any wear part attached to the mill is not properly maintained. Bearings and motor alignment should also be checked along with mounting bolts to insure a firm foundation and reduced vibration.

**Check and clean all magnets daily.** If foreign material is found, the source of this material should be determined and eliminated. Another method of cleaning should be considered to insure complete removal. **Foreign material in a mill can cause sever damage** to hammers, screens, rods, and other parts. It may cause part and subsequent hammermill failure.

**When installing or changing hammers, be sure to follow directions** on the installation diagram. If the hammers being installed have been balanced by rod, carefully follow the color coding or other instructions. Misplacement could cause excessive vibration. After installing a new set of hammers or turning a corner, watch for unusual or **excessive vibration** upon start up of the hammermill. If any occurs, **immediately shut off the power.** Check to see what is wrong and correct it before starting the mill again. Do not mix hammers from two different sets. Hammers are usually balanced per rod and not per hammer. Do not turn two hole hammers, end for end, if the hammers have excessive wear. There may not be enough metal to support them and breakage could occur.

**ALWAYS WEAR SAFETY GLASSES** when hammers are being installed, changed from one corner to another, or removed. **Do not hit hammers** during any of the above processes. Striking a hammer may cause particles to fly-off and become a safety hazard.

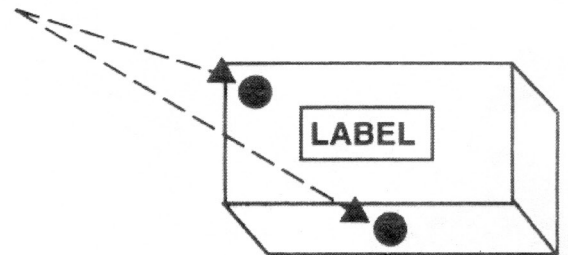


# CAUTION: READ ALL INSTRUCTIONS

- Verify box or boxes of hammers to equal complete set.
- Check parts to verify size and quantity is correct prior to installation.
- These hammers have been *balanced & color coded* to reduce vibration. To maintain the balance, hammers must be installed following the sequence below.

To save you freight and handling, a single set of hammers may be shipped in several boxes. Boxes will be color coded in two locations.

A complete set of hammers will consist of boxes marked the same color code.



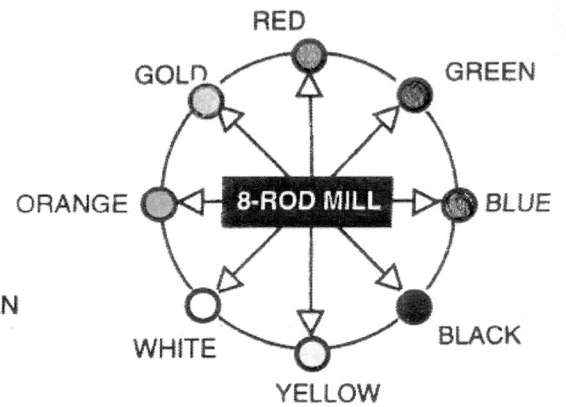
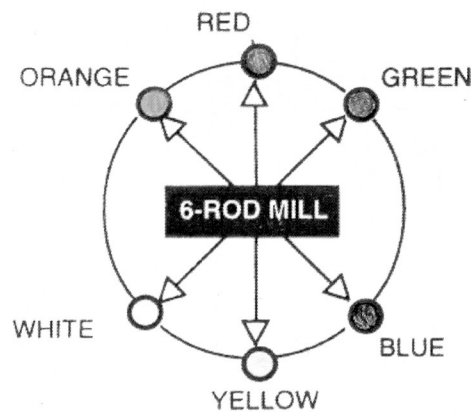
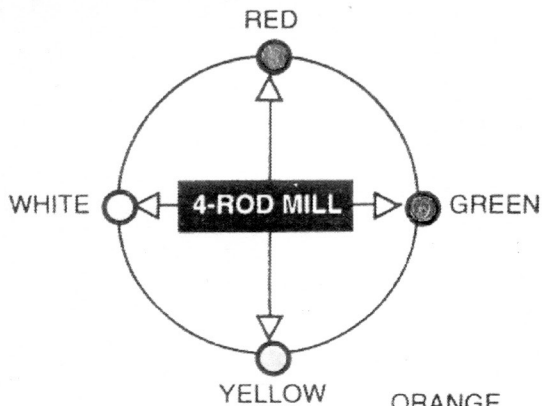
## COLOR LEGEND:

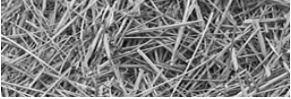
Hammers are balanced =

**RED**  
**BLUE**  
**GREEN**  
**BLACK**

opposite  
"  
"  
"

**YELLOW**  
**ORANGE**  
**WHITE**  
**GOLD**





**CAUTION:** Before entering tub to do any service work, raise the tub platform following the instructions on page 31 under the heading “Raising the Tub Platform”. After raising the tub platform follow procedures 5 through 8 of the normal shutdown procedure on page 28.

We recommend the following:

- A. Always replace hammers in pairs, 180 degrees apart. ( illustrations A & B below).
- B. Tips placed 180 degrees apart should be the same weight.

To replace the hammers on this machine, perform the following steps:

1. Raise the tub platform following the instructions on page 34 under the heading “Raising the Tub Platform”.



**WARNING:** To prevent serious injury or death, do not tilt platform on unlevel ground or with material in the tub.

**WARNING:** For your protection **ALWAYS** install the tub cylinder stop on the tub tilt cylinder when the tub is tilted. **NEVER** engage tractor PTO when the tub is raised.

2. Loosen two bolts at rear of rotor that holds the movable plate in place.
3. Rotate movable plate counter clockwise to align holes allowing hammer rods to be removed through rear of rotor.
4. Remove one row of hammers and replace, taking note as to where spacers are located. (illustrations A & B below).
5. After all hammers have been replaced or turned, turn movable plate to lock rods in place and then tighten bolts.
6. When starting the rotor after installing a new set of hammers or turning corners, watch for unusual or excessive vibration. If any occurs, immediately shut off the rotor. Check to see what is wrong and correct it before starting the rotor again.

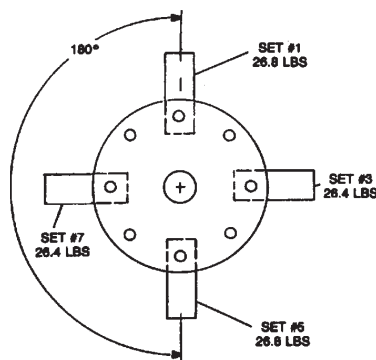


ILLUSTRATION A

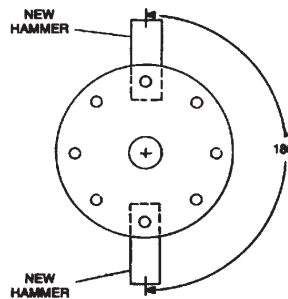


ILLUSTRATION B

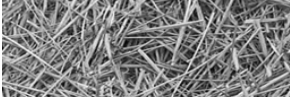
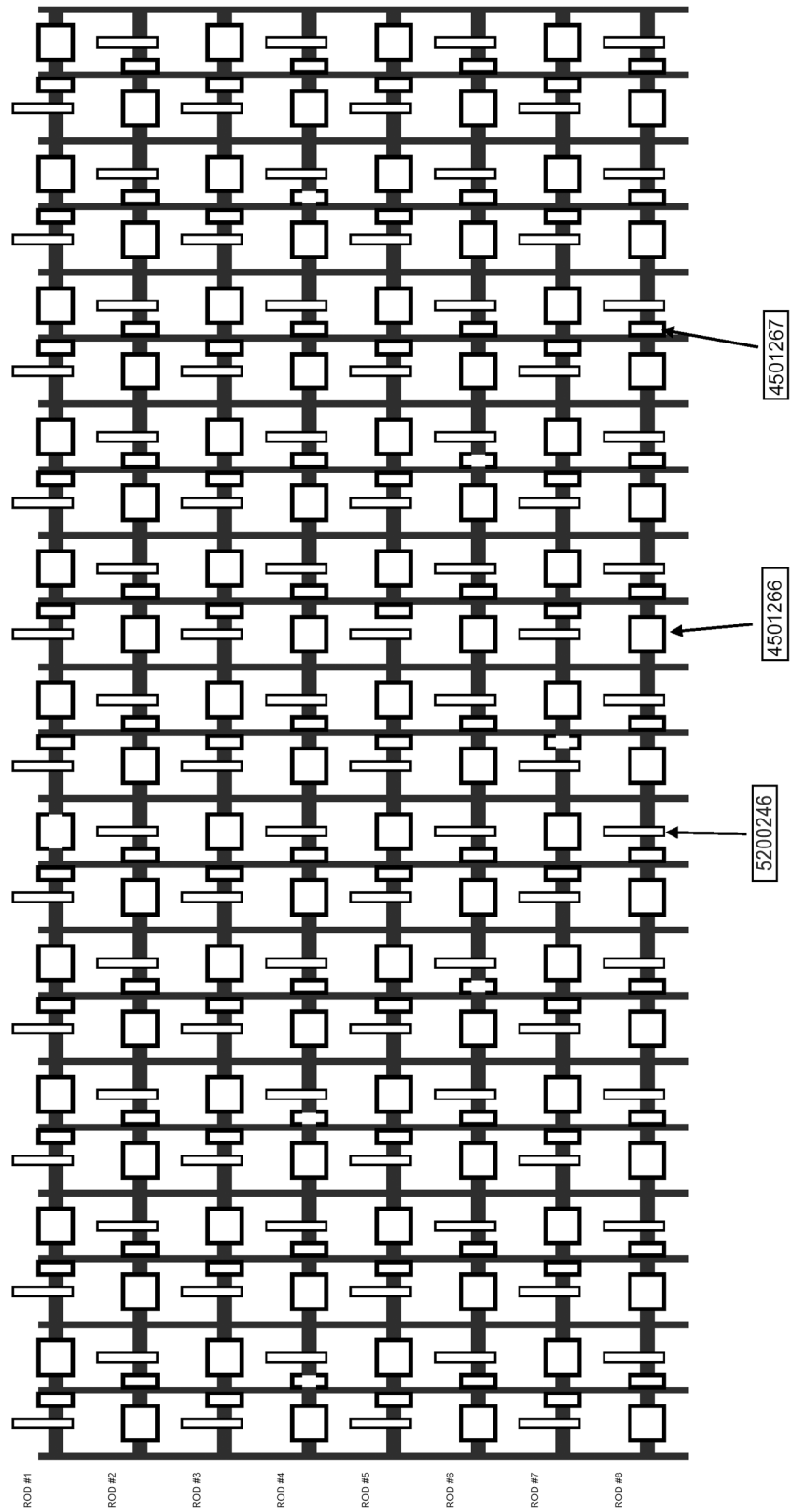


Figure 3.11  
hammer spacing chart for  
the H-1130  
(For S.N. Up to 1117090030)



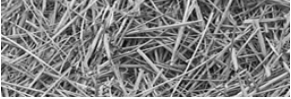
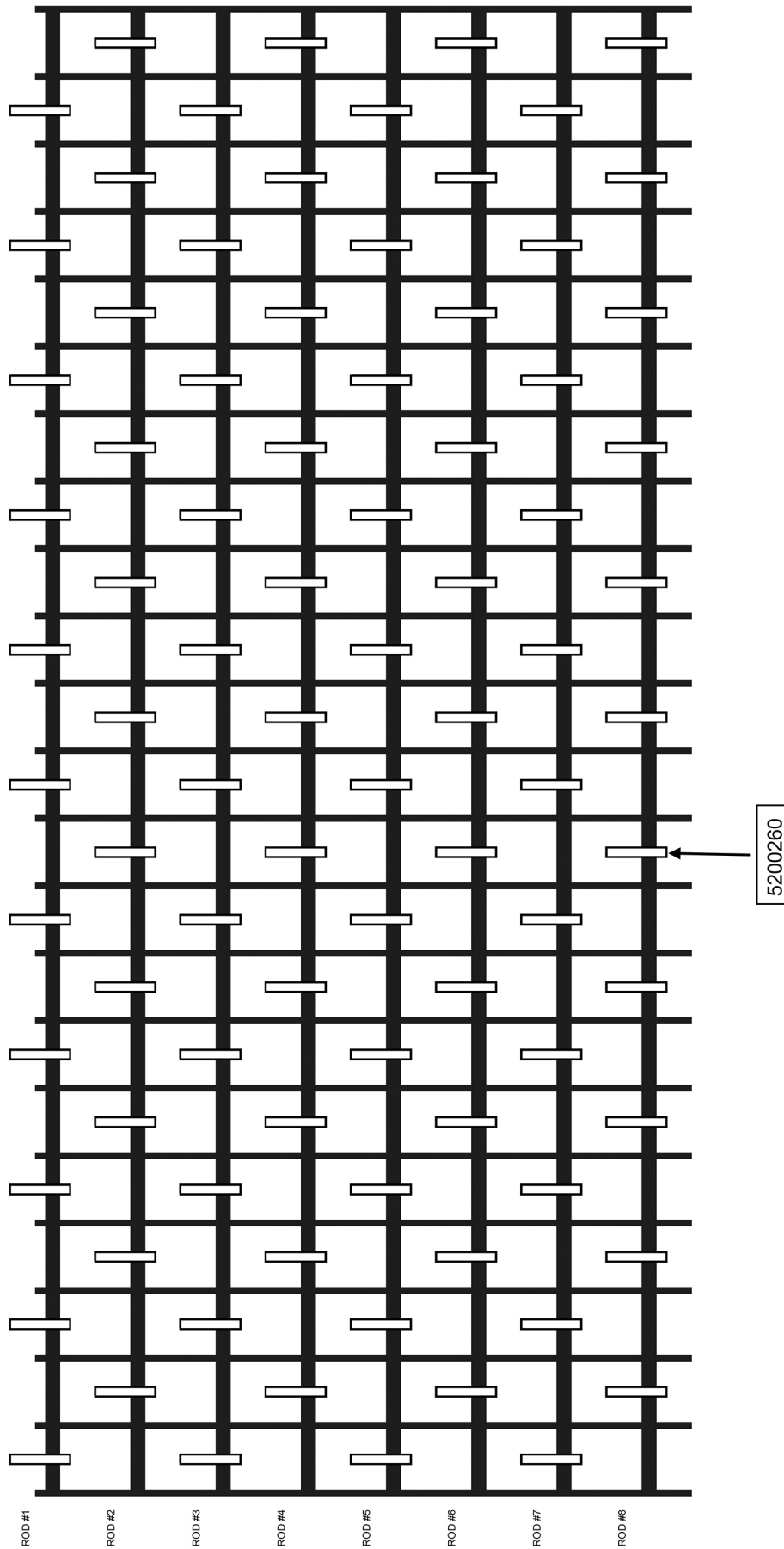
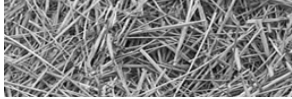


Figure 3.12  
hammer spacing chart for the  
H-1130  
(For S.N. 1118090130 and Up)





### 3.6 Dodge Rotor bearing installation



**WARNING:** To ensure the rotor is not unexpectedly started, turn off and lock out or tag the power sources before proceeding. Failure to observe these precautions could result in bodily injury.



**NOTE:** Bearing housing caps and bases are not interchangeable and must be matched with mating half. Install the non-expansion bearing first.

### Instruction Manual For IMPERIAL Adapter Mounted DODGE ISAF

#### Pillow Blocks and IP Unitized Spherical Roller Bearing Pillow Blocks, Flanges, Piloted Flanges & Take Ups

#### GENERAL INFORMATION

DODGE ISAF and IP Spherical Roller Bearing mounted units incorporate a unique way of seating, mounting, and dismounting the unit to and from the shaft. The patented sealing system (Pat. #5,908,249) has proven effective in protecting the internal bearing components, due to its constant pressure, while suit allowing a full + or 1 degree of misalignment.. The patented IMPERIAL system (Pat. #5,489.156) pulls the bearing on the adapter based upon a predetermined clockwise rotation of the locknut. Dismounting is accomplished via counterclockwise rotation of the locknut Keep in mind that the thread on the locknut as well as on the adapter is a left hand thread.



**WARNING:** To ensure that drive is not unexpectedly started, turn off and lock out or tog power source before proceeding. Failure to observe these precautions could result in bodily Injury.

#### INSPECTION

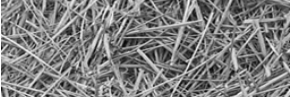
Inspect shaft Ensure that the shaft is smooth, straight, clean, and within commercial tolerance Inspect unit. Do not allow unit to be exposed to any dirt or moisture.



Keep weight off bearing during mounting via a sling or jacks



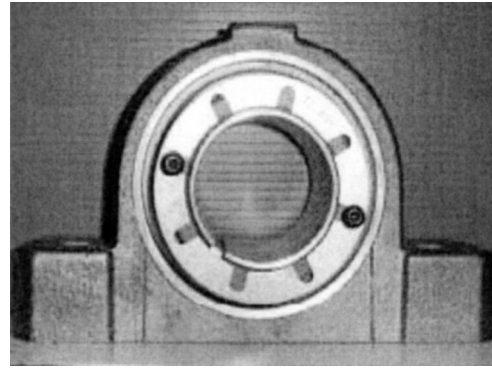
**WARNING:** Because of the possible danger to persons(s) or property from accidents which may result from the improper use of products, it is important that correct procedures be followed. Products must be used in accordance with the engineering information specified in the catalog. Proper installation, maintenance and operation procedures must be observed. The instructions in the instruction manuals must be followed. Inspections should be made as necessary to assure safe operation under prevailing conditions. Proper guards and other suitable safety devices or procedures as may be desirable or as may be specified in safety codes should be provided. and are neither provided by Baldor Electric nor are the responsibility of Baldor Electric. This Unit and its associated equipment must be installed, adjusted and maintained by qualified personnel who are familiar with the construction and operation of all equipment in the system and the potential hazards involved.



## MOUNTING

Install the non expansion unit first.

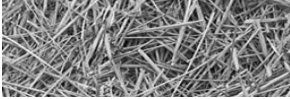
1. Apply a coating of light oil or other rust inhibitor to the adapter area of the shaft.
2. Before mounting bearing to shaft, remove lockplate from bearing and turn locknut counterclockwise one to two turns to allow adapter to expand fully. The unit is now shaft ready. Slide the bearing to the desired position on the shaft.
3. Proper locking of this unit to the shaft is based on turning the locknut clockwise 1-1/4 to 1-1/2 turns. The turning of the locknut must start from a "ZERO reference point." This "ZERO reference point" is defined as the point when the clearance between adapter sleeve, shaft and bearing bore has been removed, and all surfaces are in metal to metal contact.
- 3A. To reach the "ZERO Reference Point," rotate locknut clockwise, using both hands, as tight as possible. Continue to tighten 1-1/4 to 1-1/2 turns.



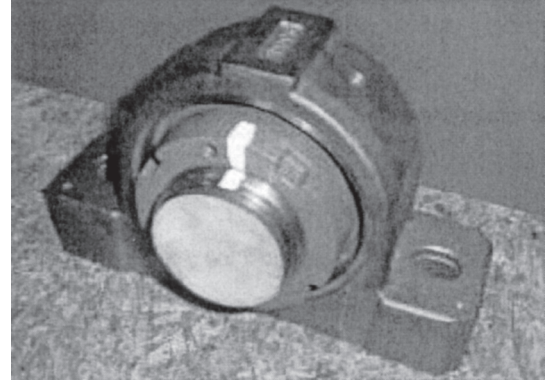
Picture 1



**NOTE:** All Weight Must Be Removed From The Bearing When Obtaining The "ZERO Reference Point."

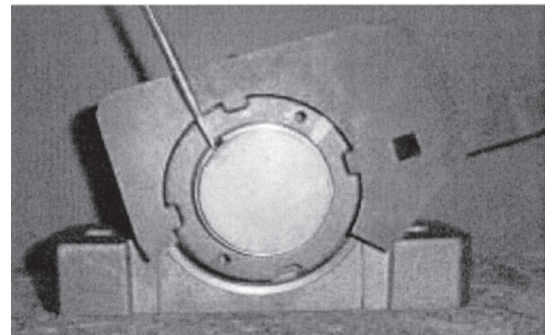


4. Once “ZERO reference point” is reached, scribe a line through both locknut face and adapter face (Picture 2). Then continue to tighten the locknut (Picture 3) by turning it clockwise using hammer and drift or spanner by the appropriate rotation angle shown on Table 1. Proper mounting has been achieved when the scribed line on the locknut has rotated from the scribed line on the adapter face by the angle shown on Table 1. To reach the full rotation of the locknut, the use of hammer blows onto spanner or drift may be needed for proper mounting.



Picture 2

5. a) Slide lockplate over shaft and align tang of lockplate with slot in adapter sleeve.  
b) Find a locknut hole that aligns with a lockplate hole. If the closest locknut hole is beyond a lockplate hole, then tighten, not loosen, the locknut to meet a lockplate hole  
c) Insert lockwasher and tighten button head screws to lock assembly. (Ref. Picture 4)
6. Bolt down pillow block or flange unit to the structure.
7. Repeat steps 1 through 6 for the expansion bearing except immediately after Step 2 do the following:



Picture 3

### EXPANSION

#### Pillow Blocks (Locknut facing outboard)

Align pillow block housing mounting holes with substructure mounting holes. Position insert in center of travel on rear expanding bearing.

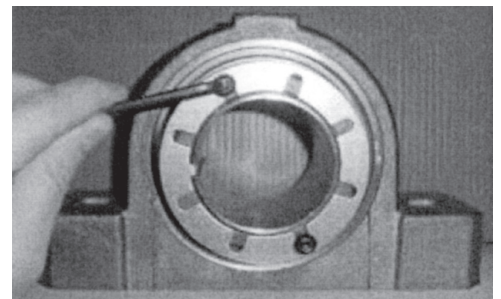


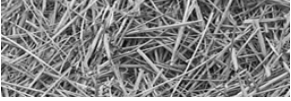
**NOTE:** This is necessary because in the process of mounting, bearing is being drawn toward locknut. **Also remember to keep weight off of bearing.**



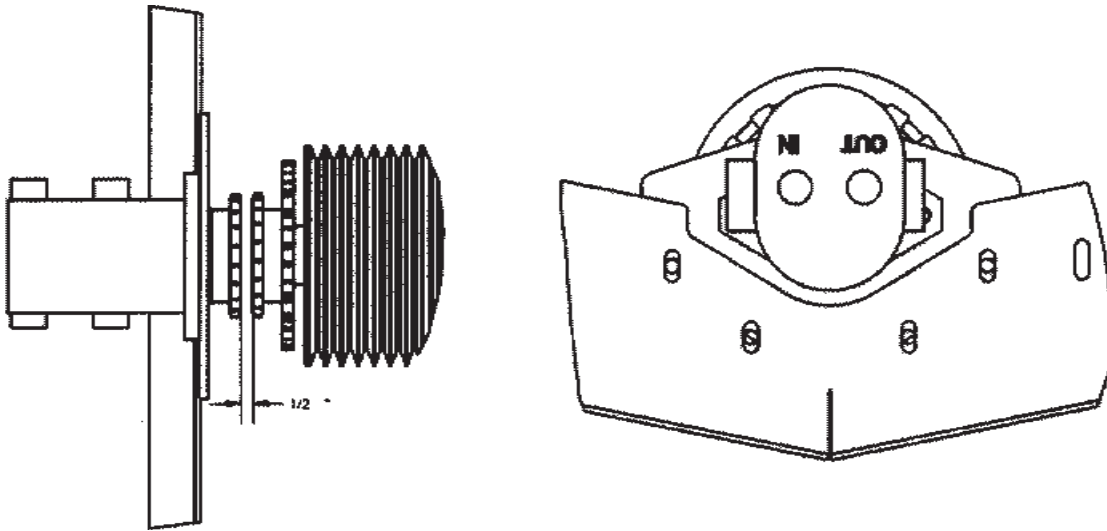
**NOTE:** Use hardened washers and properly tightened bolts to obtain sufficient clamp force between the bearing block and the mounting structure.

Picture 4



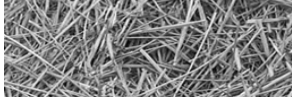


### 3.7 Installing pump drive chain coupler



The chain coupler which transfers power from the rotor to the hydraulic pump will need to be removed if new belts are installed, a new hydraulic pump is installed, or if the rotor is removed. It is important to correctly install the coupler, if not the hydraulic pump shaft will be stressed and cause pump failure. To correctly install the coupler follow these step by step instructions.

1. Tighten drive belts to recommended setting.
2. Place pump mount bracket in machine and install four bolts, tighten enough to allow bracket to move up and down in slot.
3. Measure distance between the sprockets on pump and rotor shafts. The distance between the two sprockets should be  $\frac{1}{2}$ " , if not loosen the sprocket on the rotor shaft and adjust until the distance is  $\frac{1}{2}$ ".
4. Next move the pump and bracket up or down in slots until the two sprockets are aligned vertically, use a straight edge across the teeth to determine if aligned correctly.
5. Check horizontal alignment using the procedure described above.
6. After sprockets are aligned install the double chain, the chain should be loose on the sprockets. The connecting link for the chain coupler must be located so that it will pass through the cut out in the speed pickup sprocket.
7. Close platform and engage the rotor for 1 minute.
8. Open platform and check the coupler chain, the chain should be loose on the sprockets. If the chain is tight and wedged between the sprockets the pump is not aligned with the rotor shaft and is in need of further adjustment.



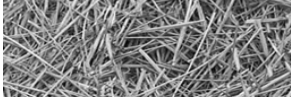
## Section 4: Troubleshooting the H-1130

### 4.1 Troubleshooting the electronic governor system

1. When power is reaching the electronic governor the fuse light should be on. If this light fails to go on, check the fuse, the battery connections, the wiring harness, and the indicator lamp.
2. Checking the TUB MODE operation of the electronic governor. With the engine and hydraulic systems at operating temperature, and the tub drive control valve in the forward position, throttle the engine up to PTO speed.

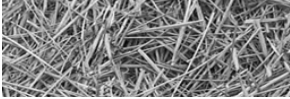
With the mode switch in the tub position, the tub should be rotating. The speed of the tub can be varied by rotating the tub limit knob. The number of tub speed lights which are lit will vary with the setting of the tub limit knob. If the number of tub speed lights lit varies as you rotate the tub limit knob, the manual portion of the controls are functioning correctly. Proceed to step 3. If the manual portion is not working properly, proceed to trouble shooting table below.

PROBLEM	CAUSE	REMEDY
1. The tub does not rotate but the electronic governor and the manual hydraulic valve are working properly. There is pressure to the orbit motor.	<ol style="list-style-type: none"> <li>1. The tub is binding.</li> <li>2. There is too much material in tub, or the tub is overloaded due to wet or tough grinding material.</li> <li>3. The pressure relief valve in the control valve set too low or is faulty.</li> </ol>	<ol style="list-style-type: none"> <li>1. Remove the material causing problem.</li> <li>2. Reduce the amount of material in the tub.</li> <li>3. Check oil pressure</li> </ol>
2. The tub does not rotate, but the valve is receiving 10 to 12 volts of DC power. There is no pressure to the orbit motor. Note: The valve refers to the valve where you disconnect the wiring harness. For more information see "Electronic governor hardware test" later in this section.	<ol style="list-style-type: none"> <li>1. The manual hydraulic valve is not engaged.</li> <li>2. The valve assembly is dirty or faulty.</li> <li>3. The solenoid is faulty.</li> </ol>	<ol style="list-style-type: none"> <li>1. Engage the manual hydraulic valve.</li> <li>2. Clean or replace the valve assembly.</li> <li>3. Test the solenoid and replace as necessary.</li> </ol>
3. The tub does not rotate, and there is no voltage to the valve.	<ol style="list-style-type: none"> <li>1. There is no power to the electronic governor.               <ol style="list-style-type: none"> <li>a The electronic governor is switched off.</li> <li>b The fuse is blown.</li> <li>c The tub limit knob is set fully counterclockwise.</li> </ol> </li> <li>2. A wire in the wiring harness is broken.</li> <li>3. The electronic governor is faulty.</li> </ol>	<ol style="list-style-type: none"> <li>1.               <ol style="list-style-type: none"> <li>a Switch the electronic governor mode switch to tub.</li> <li>b Replace the fuse.</li> <li>c Turn the tub speed knob clockwise.</li> </ol> </li> <li>2. Replace or repair the wiring harness.</li> <li>3. Replace the electronic governor.</li> </ol>
4. The tub runs with the electronic governor switch off. Disconnect the wiring harness at the valve. A. If the tub stops B. If the tub keeps turning	<ol style="list-style-type: none"> <li>1A. The electronic governor is out of adjustment.</li> <li>2.A The electronic governor is faulty.</li> <li>1B. The valve override screw is adjusted in too far.</li> <li>2.B The valve is faulty.</li> </ol>	<ol style="list-style-type: none"> <li>1.A Readjust the electronic governor.</li> <li>2.A Replace electronic governor.</li> <li>1.B Adjust the override screw.</li> <li>2.B Replace the valve.</li> </ol>
5. The tub speed can not be varied with the tub limit knob.	<ol style="list-style-type: none"> <li>1. Valve override is not adjusted correctly.</li> <li>2. The valve is stuck.</li> <li>3. The solenoid is stuck.</li> <li>4. The electronic governor is faulty.</li> </ol>	<ol style="list-style-type: none"> <li>1. Adjust the override screw.</li> <li>2. Clean or replace the valve assembly.</li> <li>3. Test the solenoid and replace as necessary.</li> <li>4. Replace the electronic governor.</li> </ol>



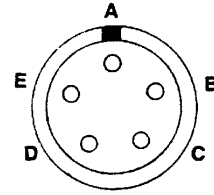
3. Checking the ENGINE MODE operation of the electronic governor. If the tub mode controls function correctly after following the tub mode trouble shooting check list, then follow the calibration instructions on page 34 of this manual. If the tub will not rotate, proceed to trouble shooting table below.

PROBLEM	CAUSE	REMEDY
1. The tub will not rotate, and the sensor light is not lit.	<ol style="list-style-type: none"><li>1. The sensor gap is out of adjustment.</li><li>2. There is a broken wire on the wiring harness</li><li>3. The sensor is faulty.</li><li>4. The sensor light bulb is faulty.</li><li>5. The electronic governor is faulty.</li></ol>	<ol style="list-style-type: none"><li>1. Readjust the sensor gap to 3/32". This is roughly the thickness of a nickel.</li><li>2. Repair or replace the wiring harness.</li><li>3. Test and replace the sensor as necessary.</li><li>4. Replace the sensor light bulb</li><li>5. Replace the electronic governor.</li></ol>
2. The tub will not rotate, and the sensor light is lit.	<ol style="list-style-type: none"><li>1. The tub limit knob is set to "turtle".</li><li>2. The manual hydraulic valve is in the neutral position.</li><li>3. The electronic governor is faulty.</li></ol>	<ol style="list-style-type: none"><li>1 Adjust the tub limit knob to a value toward rabbit.</li><li>2 Engage the manual hydraulic valve.</li><li>3. Replace the electronic governor.</li></ol>



## ELECTRONIC GOVERNOR HARDWARE TEST

1. Power source: 12 volts DC  
 Red wire + positive pin A wiring harness  
 Black wire - Negative Pin B wiring harness
2. Test output voltage to valve DC  
 Red wire + positive pin D wiring harness.  
 Black wire - negative pin E. wiring harness.



- A - 12 volts DC**
- B - Ground**
- C - Digital sensor signal**
- D - (+) to valve**
- E - (-) to valve**

Test the electronic governor with power supplied to the governor control box and the mode switch set to the tub position. The grinder does not need to be running for this test. Disconnect the wiring harness at the valve. With a voltmeter set for 12 volts DC, connect the red lead of the voltmeter to the red lead of the wiring harness and black lead to the black wire. Turn the tub limit knob until the left speed light (turtle) is on. The voltmeter should read approximately 3 volts. Turn the tub limit knob clockwise. As more speed lights light up, the voltage should increase. Turn the knob until the right speed light (Rabbit) is lit. The volt meter should now read a minimum of 9 volts.

3. Output voltage of sensor AC  
 red wire - Pin C wiring harness  
 Black wire - Pin B wiring harness.

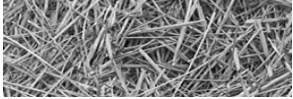
Set the sensor gap to 3/32".

Remove the wiring harness from the electronic governor.

With the grinder at operating speed. Set volt meter to AC volts, connect leads to pins B and C. The volt meter should read at least 2 to 3 volts AC.

## ELECTRONIC GOVERNOR VOLT-OHM READINGS ELECTROHYDRAULIC VALVE COIL TEST

WIRE HARNESS CONNECTOR	ENGINE	IGNITION SWITCH	READING	INCORRECT READING INDICATES	CHECK IF INCORRECT READING
Valve terminals, system in Manual (Wires attached)	Not Running	ON	13 volts DC	Defective wiring, control box	Wires to valve
Valve terminals, system in Auto (Wires attached)	Running 1500 to 2550 rpm	ON	1-10 volts DC varies with rpm *	Defective wiring, control box	Wires to valve
Valve terminals, (Wires removed)	Not Running	OFF	8-12ohms	Defective solenoid valve	
Pin A to B	Not Running	ON	13 volts DC	13 volts not at control box, no ground	Wires to tractor
Pin A to Ground	Not Running	ON	13 volts DC	13 volts power not reaching box	Wires to tractor
Pin B to Ground	Not Running	OFF	Less than 5 ohms	Black wire not grounded	Ground Wire
Pin D to E	Not Running	OFF	8-12 ohms	Valve wiring or solenoid valve defective	Wires to valve, valve



This test requires an accurate ohm meter. Disconnect the wiring harness leads at the electro-hydraulic valve coil. Check resistance of valve coil leads at the terminals. The resistance should be between 8 to 12 ohms for a 12 volt solenoid. If the values are not within this range, replace the electro-hydraulic valve coil.

#### MANUAL OVERRIDE

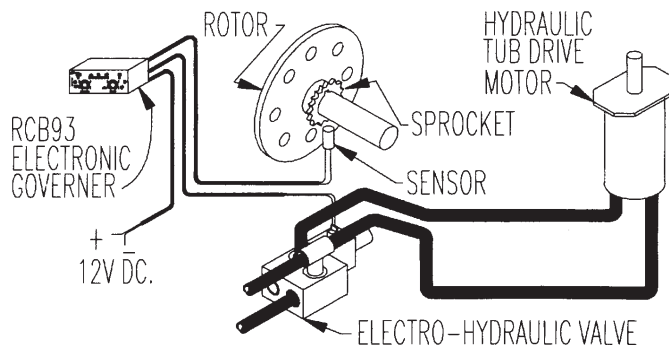


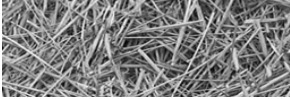
**NOTE:** If there is an electrical failure with the machine, it may still be able to grind. Switch the electronic governor off. Remove the rubber end cap and loosen the jam nut on the electro-hydraulic valve. Start the machine and engage the tub drive.

**IMPORTANT! - DO NOT ENGAGE THE PTO AT THIS TIME!**

Turn the adjusting screw clockwise until the tub rotates at the desired speed. Lock the jam nut on the adjusting stud and replace the rubber end cap on the electro-hydraulic valve. When the electro-hydraulic valve is adjusted in this manner, it will function only as a manual flow control. The grinder will now operate as it would if the electronic governor were switched to the tub (manual) mode. The tub speed will be constant and it will not change to match varying load conditions.

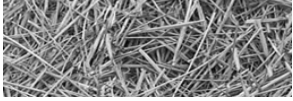
Contact your dealer for future repairs or replacement parts. When the problems are corrected, calibrate the electro-hydraulic valve.





## 4.2 General Troubleshooting

<p>1. No grinding capacity</p>	<p>1. The screen is plugged. 2. The hammers or screens are badly worn. 3. Materials are too light or fluffy.</p>	<p>1. Clean out the holes in the screen. 2. Replace or turn worn parts. 3. Mix the lighter material with heavier material. 4. Use a larger screen. 5. Use the grapple loader to force feed the material.</p>
<p>2. The tub slows down or turns slowly.</p>	<p>1. The electronic governor is not adjusted properly. 2. The electronic governor system malfunctions. 3. The hydraulic pressure is low.</p>	<p>1. See the sections on the electronic governor in the operations section of this manual. 2. See Troubleshooting the electronic governor in this manual. 3a. Check oil pressure. 3b. Look for internal leakage or wear in the orbit motor or pump.</p>
<p>3. The machine vibrates excessively.</p>	<p>1. A hammer is broken. 2. The rotor bearing is defective. 3. The driveline is worn or misaligned. 4. Foreign material is wrapped in the rotor. 5. The hammer pattern is incorrect.</p>	<p>1. Replace the broken hammer. See page 54 for more information about replacing hammers. 2. Replace the rotor bearing. 3. Replace worn part or the complete driveline. 4. Remove the foreign material. 5. See page 54 for more information about replacing hammers.</p>
<p>4. The engine looses excessive RPM's before the tub stops.</p>	<p>1. The electronic governor is not adjusted properly.</p>	<p>1. See the sections on the electronic governor in the operations section of this manual.</p>
<p>5. The tub stalls.</p>	<p>1. The tub hydraulic system pressure is set too low. 2. The tub is overloaded due to wet or tough grinding materials. 3. Too much material in the tub. 4. The tub is binding. 5. The hydraulic oil is too hot causing electronic governor valve to bind.</p>	<p>1a. Check oil pressure. 1b. Readjust the pressure relief valve to 2,000 PSI max. 2. Reduce amount of material in tub or shift the hydraulic tub drive to low range. 3. Reduce the amount of material in tub. 4. Remove material buildup between the tub and the platform framework. 5. Reduce the load on the hydraulic system, or stop and allow the hydraulic oil to cool.</p>
<p>6. The hydraulic oil overheats.</p>	<p>1. Pressure relief valve in control valve is faulty. 2. The tub is overloaded. 3. Worn pump, control valve, hyd. motors, etc. 4. Creating excessive heat with discharge conveyor flow control valve.</p>	<p>1. Check oil pressure. 2. Reduce the amount of material in the tub. 3. Rebuild or replace the hydraulic components as necessary. 4. Allow discharge conveyor to run at full speed.</p>



## Appendix A: Warranty

DuraTech Industries International Inc. warrants to the original purchaser for 12 months from purchase date that this product will be free from defects in material and workmanship when used as intended and under normal maintenance and operating conditions. This warranty is limited to the replacement of any defective part or parts returned to our factory in Jamestown, North Dakota, USA, within thirty (30) days of failure.

This warranty shall become void if in the judgment of DuraTech Industries International, Inc. the machine has been subject to misuse, negligence, alterations, damaged by accident or lack of required normal maintenance, or if the product has been used for a purpose for which it was not designed.

All claims for warranty must be made through the dealer which originally sold the product and all warranty adjustments must be made through same.

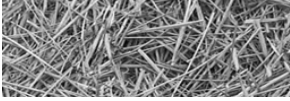
This warranty does not apply to tires or bearings or any other trade accessories not manufactured by DuraTech Industries International Inc. Buyer must rely solely on the existing warranty, if any, of these respective manufacturers.

DuraTech Industries International Inc., shall **not** be held liable for damages of any kind, direct, contingent, or consequential to property under this warranty. DuraTech Industries International Inc., cannot be held liable for any damages resulting from causes beyond its control. DuraTech Industries International Inc., shall **not** be held liable under this warranty for rental costs or any expense or loss for labor or supplies.

DuraTech Industries International Inc., reserves the right to make changes in material and/or designs of this product at any time without notice.

This warranty is void if DuraTech Industries International Inc. does not receive a valid warranty registration card at its office in Jamestown, North Dakota, USA, within 10 days from date of original purchase.

All other warranties made with respect to this product, either expressed or implied, are hereby disclaimed by DuraTech Industries International Inc.



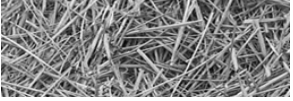
## Appendix B: H-1130 Specifications

Weight .....	13,300 lbs. (6,033 kg)
Width at Flare .....	11 ft 4 in. (354 cm)
Loading Height .....	9 ft 2 in (279 cm)
Transport Height.....	10 ft 7 in (323 cm)
Transport Length .....	21 ft 7 in (658 cm)
Wheels .....	Drop center rims, Tapered roller bearings
Bearings .....	All standard size, grease sealed
Recommended Tire Size .....	16.5L X 16.1 High flotation implement (14 ply)
Recommended Cylinder Speed .....	2300 rpm
Capacity .....	Hay - up to 40 tons/hr.
.....	Ear corn - up to 800 Bu/hr.
.....	Grain and shelled corn -Up to 3400 Bu/hr.
Rotor - Std No. of Hammers .....	88
Hammer Size .....	2-1/2" x 7-3/4" x 1/2" (6 cm x 20 cm x 1 cm)
Rotor - Shaft diameter .....	3-1/2 in. (9 cm) stress proof steel
Rotor Size .....	50 in. long, 26 in. diameter with hammers extended
Screen Area .....	2,781 sq. in. (17,942 sq. cm.)
Screens Available (inches) .....	1/8, 3/16, 1/4, 3/8, 1/2, 5/8, 3/4, 1, 1-1/2, 2, 3, 4,5, 6, 7, 8 Round holes. 2,3,4 Slotted Holes
Feed Delivery .....	26 ft. folding rubber belt conveyor w/cleats 24 in. Wide
Tub size .....	107 in. (272 cm) ID
Tub Depth .....	.50 in. (127 cm)
Tub Drive .....	Electro-Hydraulic

## Options

AVAILABLE OPTIONS FOR DURATECH INDUSTRIES H-1130 TUB GRINDER:

- Ear Corn Kit
- Geyser Plate
- Grain Grinding Hopper
- Mill Grate / Slugbar Combination
- Various Screens Sizes
- Material Guide



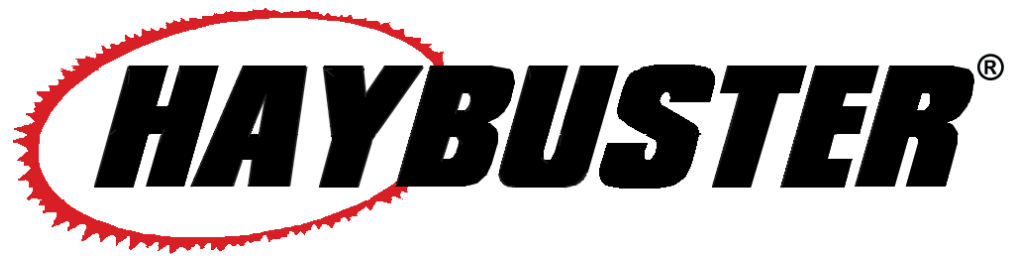
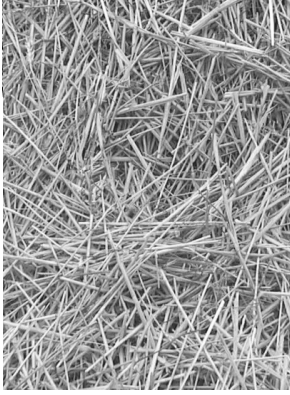
## **Appendix C: Required for operation**

Tractor - 150 to 315 hp

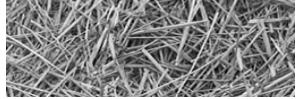
1000 RPM PTO Shaft

Dual Hydraulics, double acting control valve, 8 GPM, 1500 psi (103 BAR)

See also Section 2.3.1, Tractor Set Up.



**H-1130<sup>TM</sup>**  
**Tub Grinder Stationary**  
**Electric Supplement**  
**Operating Instructions**



# H1130 Electric Tub Grinder Operators Manual Supplement

This is a supplement to the H1130 Tub Grinder Operators Manual and Parts book. The main part of this book applies to this Tub Grinder except where described in this attached supplement.

**Before Starting the H1130 Electric Tub Grinder review all:**

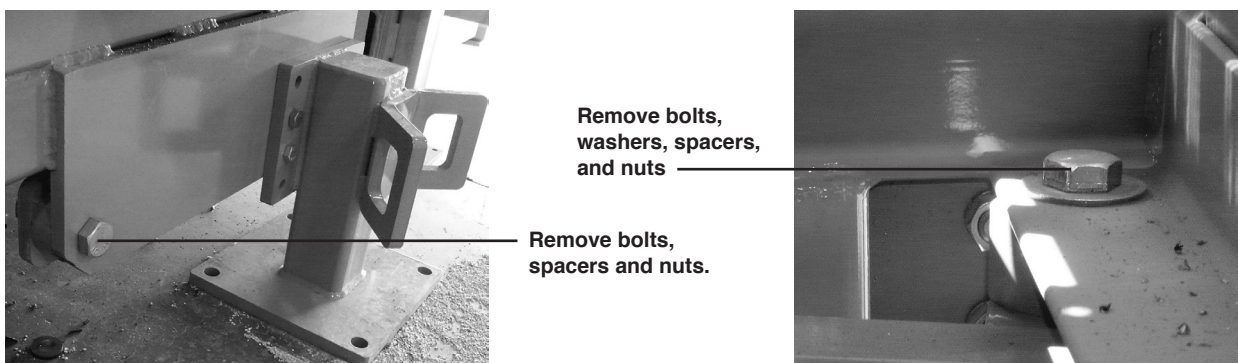
- Safety Recommendations – See **Section 1** of this operator’s manual
- Pre-Operation – See **Section 3** of this operator’s manual
- *Safetronics Instructional Manual* – for all information regarding the soft start controller.

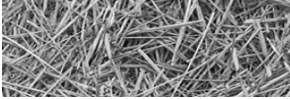
## Supplement Section 1: Set-Up (For S.N. 0651 And Up)

1. Unbolt front legs from hitch and reorient so that they are positioned like the rear legs of the control panel assembly and bolt back on.



2. Disconnect the control box assembly from the machine by removing the bolts, spacers and nuts on both sides of the machine. (Total of four bolts.)



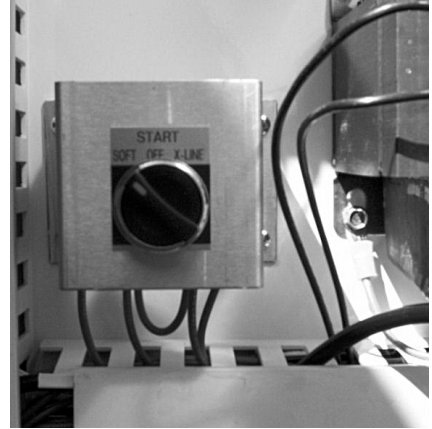


## Supplement Section 2: Start-Up (For S.N. Up To 0650)



**Warning:** Make sure that all safety measures have been taken before switching on the power supply.

1. Before starting the H1130 Electric Tub Grinder make sure that “**Start**” switch in the control panel is set on “**soft**”.
2. Shout the word “CLEAR”



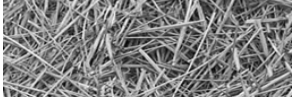
**Note:** Next step will bring grinder up to full operating RPM

3. Then press the start button on the outside of the control panel.

Start button  
(Bottom, green  
button)



**Note:** Electric motor will not start if platform is raised.



## Supplement Section 2: Start-Up (For S.N. 0651 And Up)



**Warning:** Make sure that all safety measures have been taken before switching on the power supply.

1. Before starting the H1130 Electric Tub Grinder make sure that “**Start**” switch in the control panel is set on “**SS**”.
2. Shout the word “**CLEAR**”



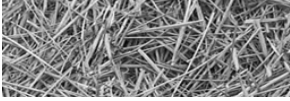
**Note:** Next step will bring grinder up to full operating RPM

3. Then press the start button on the outside of the control panel.

Start button  
(green button)



**Note:** Electric motor will not start if platform is raised.



### Supplement Section 3: Shut-Down Procedure (For S.N. Up To 0650)

1. Run H1130 Tilt Tub Grinder until discharge conveyor is empty, and grind as much of the material in the tub as possible.
2. Push stop button.

Stop button  
(Top, red button)

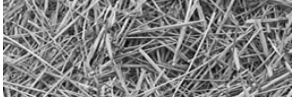


### Supplement Section 3: Shut-Down Procedure (For S.N. 0651 And Up)

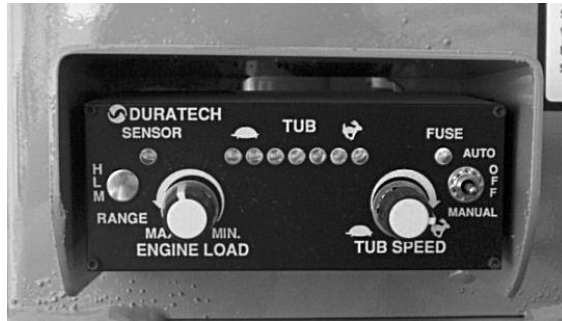
1. Run H1130 Tilt Tub Grinder until discharge conveyor is empty, and grind as much of the material in the tub as possible.
2. Push stop button.

Stop button  
(red button)





## Supplement Section 3: Governor System



Electric motor speeds change very little between no load and full load conditions, necessitating a change of systems from the engine driven and P.T.O. units.

A current transformer sensor sends a variable signal to the electronic governor as the current flow varies. The electronic governor then sends a varying signal to a solenoid valve that diverts some oil from the tub drive and reduces tub rotational speed. As the load increases on the motor (and increases the current flow), the tub slows down, reducing the load on the rotor.

A 12 Volt DC power supply is provided with the H1130 Electric Tub Grinder to power the Electronic Governor system.

Refer to the grinder operator's manual for calibrating and operating the Electronic Governor system.

### The electric governor includes the following:

#### Fuse Light

This light is on whenever the electric governor is receiving power.

#### Sensor Light

This light is on whenever the electronic governor is receiving a signal from the sensor.

#### Speed Lights

This provides a relative indication on how fast your tub should be turning.

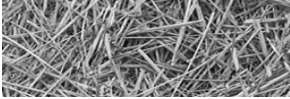
#### Mode Switch

The mode switch has three positions.

**Off** - Turns the electric governor off, the tub will not rotate in the off Position.

**Manual** - Tub rotates at constant speed based on position of tub speed knob. Tub speed does not vary and is not affected by load placed on motor. This mode should be used for maintenance only and not for grinding.

**Auto** - In auto mode the electronic governor decreases tub speed as the load on the motor increases. Maximum tub rotational speed is set by the tub speed knob, tub speed decreases proportionally to the motor load and the tub will stop rotating when maximum motor load is reached. The motor load is adjusted using the engine load knob.



## Tub Speed Knob

In auto mode the electronic governor decreases tub speed as the load on the motor increases. Maximum tub rotational speed is set by the tub speed knob, tub speed decreases proportionally to the motor load and the tub will stop rotating when maximum motor load is reached. The motor load is adjusted using the engine load knob.

This knob sets the maximum speed at which the tub will rotate in both the manual and auto modes. In the auto mode tub speed will vary between zero and this setting depending on the motor load.

## Engine Load Knob

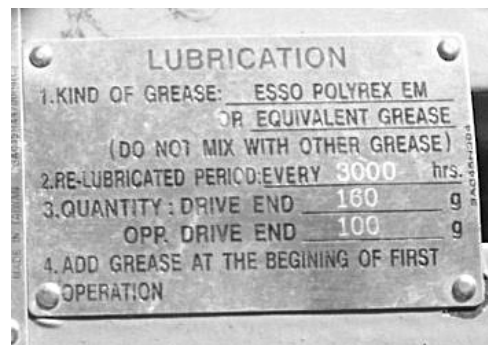
This knob is used only in the auto mode. It controls the load placed on the electric motor. Turning the knob clockwise decreases the load, and turning the knob counterclockwise increases the load.

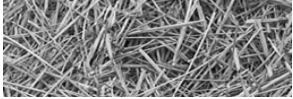
To determine where to set the engine load knob:

1. Find the full load current on the motor nameplate.
2. Multiply the full load current by .90.
3. Adjust the engine load knob while grinding so that the tub stops when current draw is equal to 90% of full load current. You can find the current draw of the motor displayed on the starter keypad display. Refer to Emotron instruction manual for information on how to navigate through the screens on the keypad.

## Supplement Section 4: Lubrication

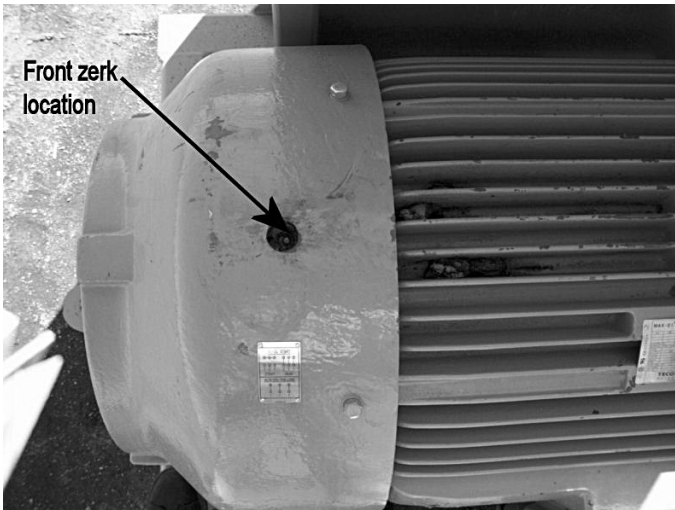
Teco-Whitewestinghouse Motor *requires* the use of **Esso Polyrex Em** or equivalent grease. The (2) grease zerks on this motor must be re-lubricated every 3000 hours. 160 grams of grease is to be placed in the drive end zerk. 100 grams required for end opposite the drive.



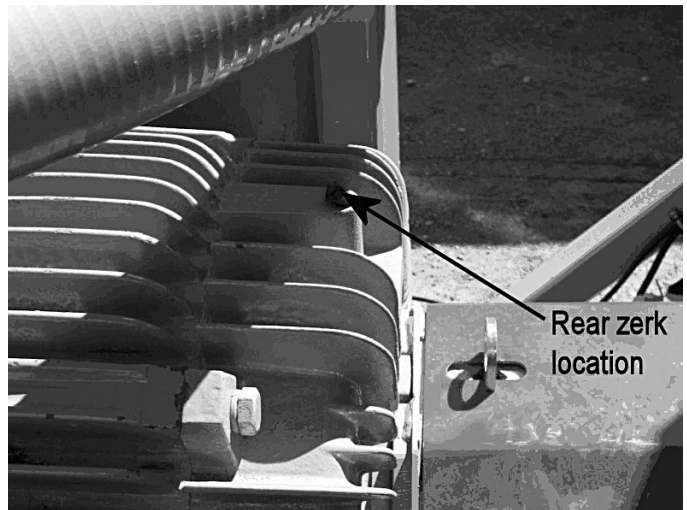


The locations of the grease zerks for the motor are shown below.

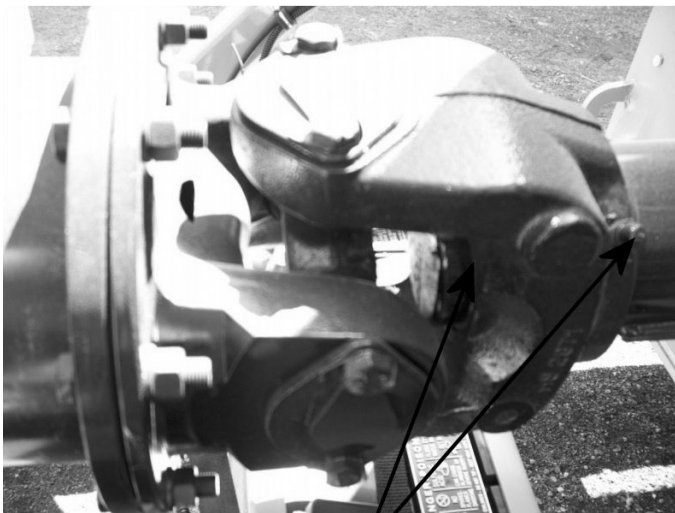
Front location (top of motor)

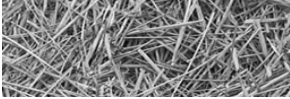


Drive end location (top of motor)



The P.T.O. shaft has (3) grease zerks that need to be lubricated every 40 hours. These locations are shown below.

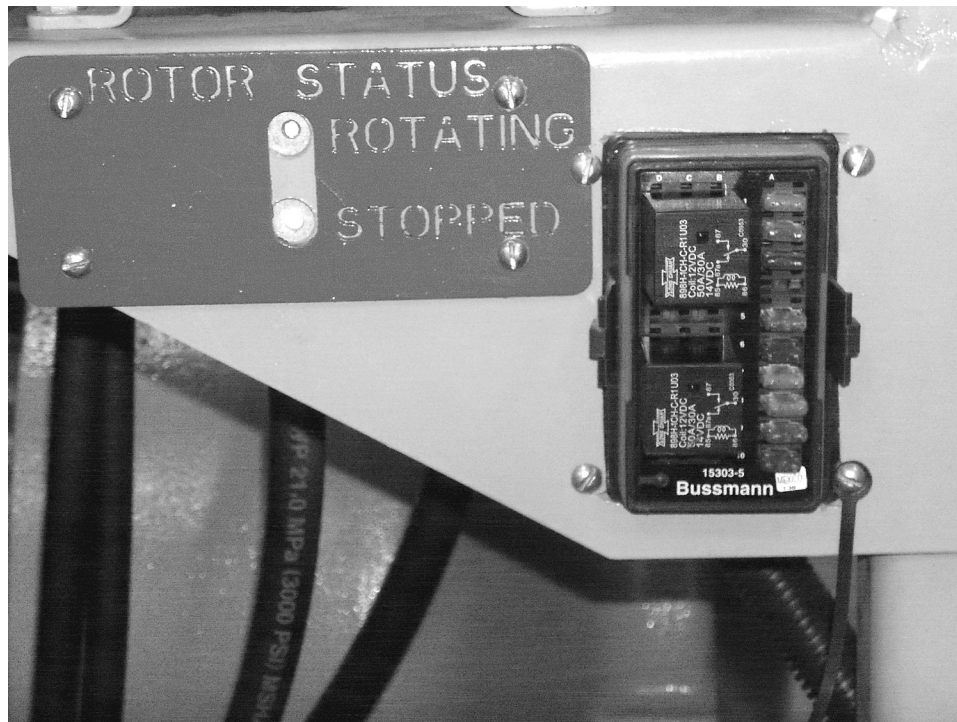


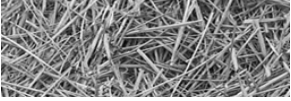


### **Supplement Section 5: Raising/lowering the tub platform, raising/lowering the discharge conveyor, and folding/unfolding the discharge conveyor.**

A 10Hp electric motor powers a hydraulic pump which provides hydraulic oil to raise/lower the tub platform, raise/lower the discharge conveyor, and fold/unfold the discharge conveyor. The conveyor function valve is located on the left hand side of the machine while the tub platform valve is located on the right hand side.

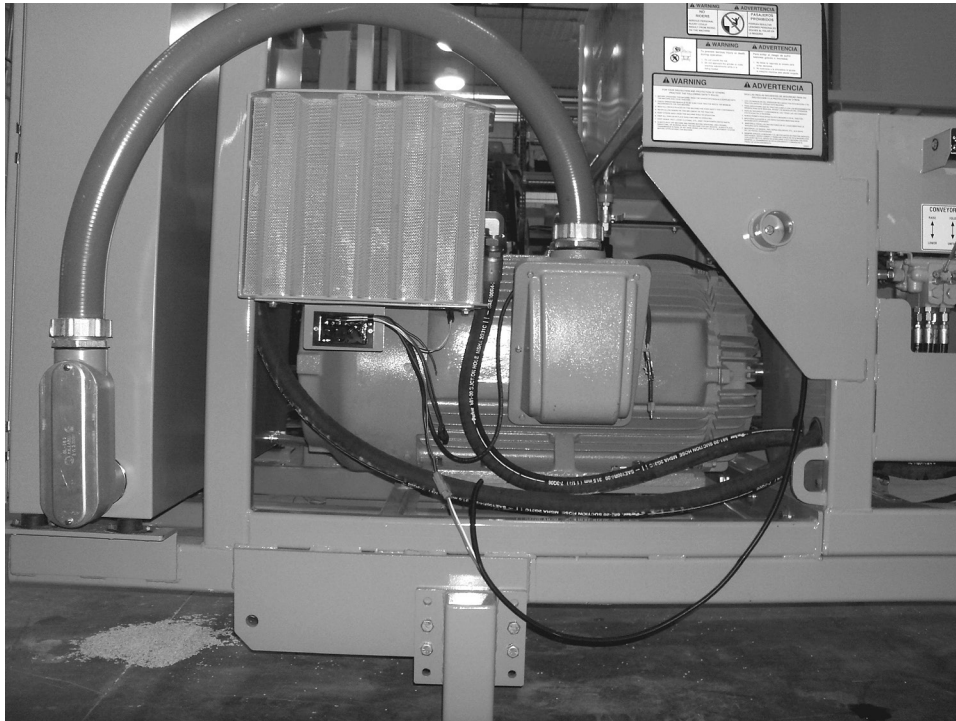
Activating a lever on either valve will start the electric motor which provides oil to the circuit. If the rotor is turning the tub platform cannot be raised/lowered. The rotor must come to a complete stop before the tub platform valve will turn on the pump. The rotor status can be found on the indicator lights below the tub platform valve. The conveyor valve will operate regardless of the rotor status.





## Supplement Section 6: Hydraulic cooler

The 1130 electric grinder is equipped with DC motor driven hydraulic oil cooler to provide supplemental cooling of the hydraulic oil. The fan on the cooler is driven by a DC electric motor. The fan on/off and direction is regulated by a controller based on the oil temperature. Air is sucked through a screen box which the cooler is attached to. Once the oil is above 125°F the fan is turned on bringing air over the cooler fins. Debris is stopped by the screen as air passes through to the cooler. If the screen plugs up and air flow is decreased to the cooler the oil will heat up, once the oil reaches 170°F the fan will stop and then reverse for 30 seconds. The debris will be blown off of the screen and the fan will resume in the forward direction. The fan will turn off once the oil temp falls below 105°F.



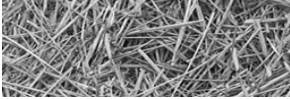
### Indicator LED's

The controller has 2 LED's which display the system status. The green LED will light when power to the system is applied and no errors are detected. The red LED will blink if there are faults to the output (fan motor). The output is monitored for no-load or overload conditions. If a fault condition occurs, count the number of blinks of the red LED, then refers to the error codes below:

**RED ERROR CODE LED BLINKS:**  
**1 TIME = FAN OVERLOAD**  
**2 TIMES = FAN OPEN**

### Explanation:

- 1 The controller is overheating. Either the fan is drawing more current than it should, or the controller is not being cooled sufficiently.
- 2 The fan is not connected. Check for broken wires. The minimum current draw must be 2A to keep the system from showing an error.

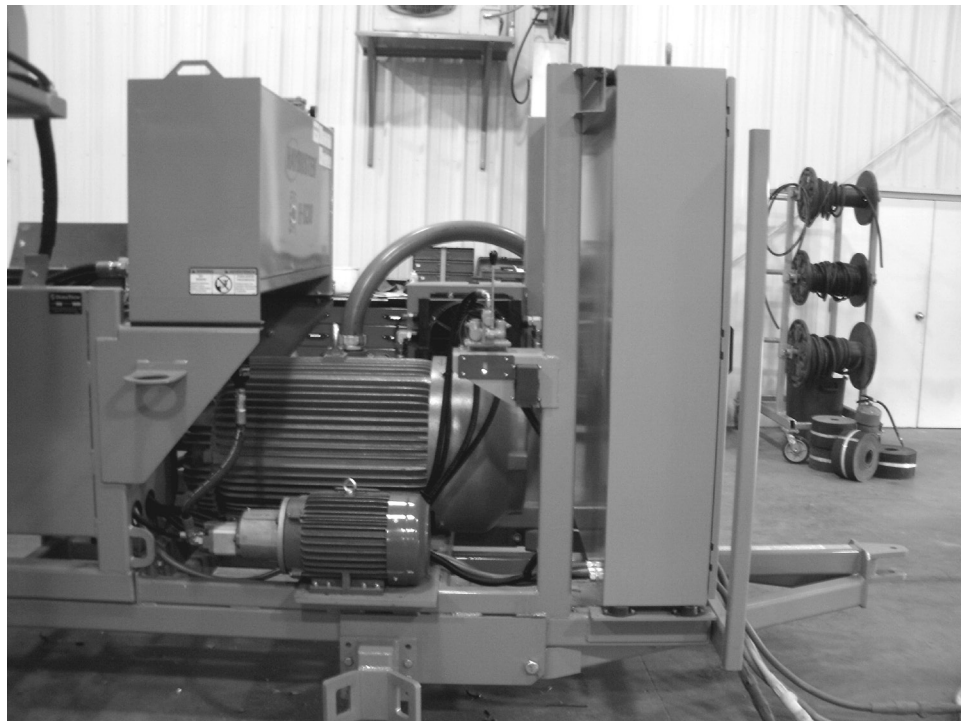


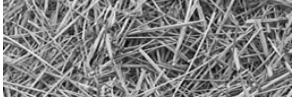
## Supplement Section 7: Transport Hitch

The 1130 electric is shipped with a hitch installed to aid in loading, transporting to the job site, and to protect the starter panel during shipment. This hitch is designed for low speeds (5 mph and under) and is not to be used for road transport.



**Attention:** The 1130 electric is not designed for road transport, transporting the 1130 over 5 mph can cause machine damage and will void the warranty!!!





# H-1130 Electric Specifications

Weight .....20,500 lbs. (9,299 kg)  
 Width at Flare ..... 11 ft 4 in. (354 cm)  
 Loading Height .....9 ft 2 in. (279 cm)  
 Transport Height..... 10 ft 6 in. (320 cm)  
 Transport Length ..... 24 ft 11 in. (759 cm)  
 Wheels ..... Drop center rims, Tapered roller bearings  
 Bearings ..... All standard size, grease sealed  
 Recommended Tire Size .....16.5L X 16.1 High flotation implement (14 ply)

Capacity ..... Hay - up to 40 tons/hr.  
 ..... Ear corn - up to 800 Bu/hr.  
 ..... Grain and shelled corn -Up to 3400 Bu/hr.

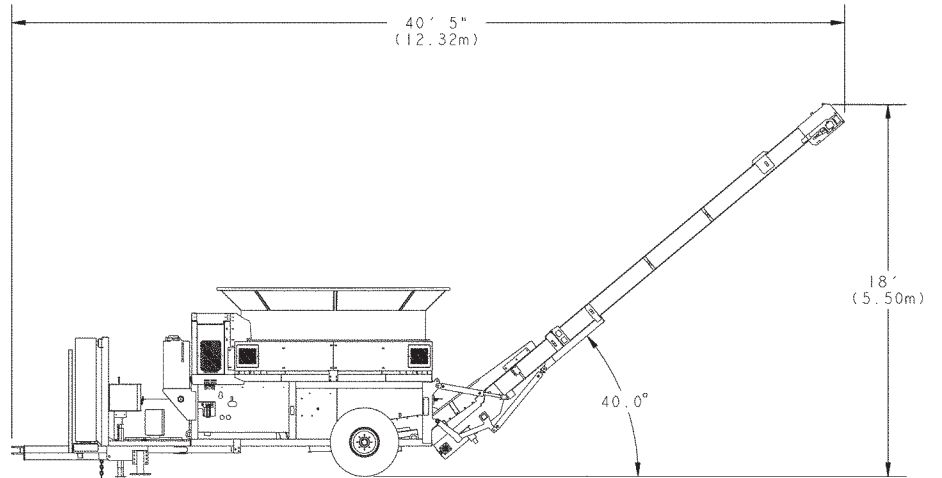
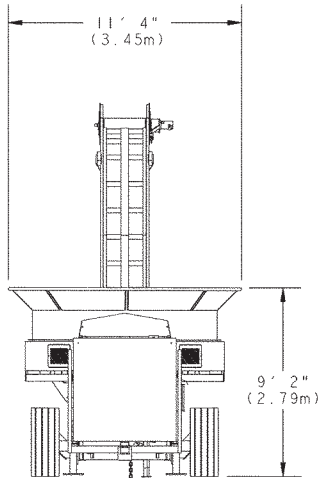
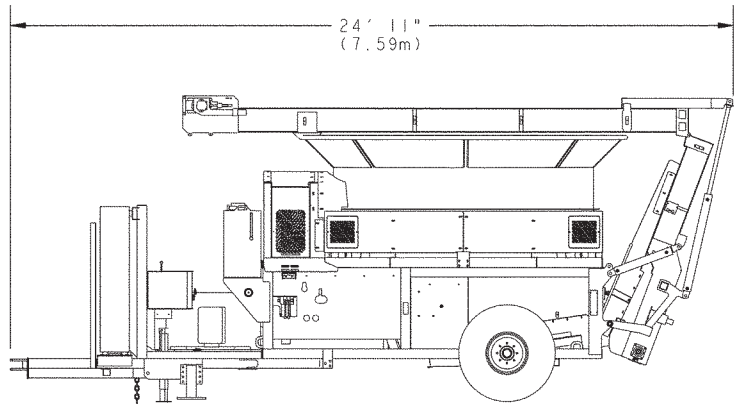
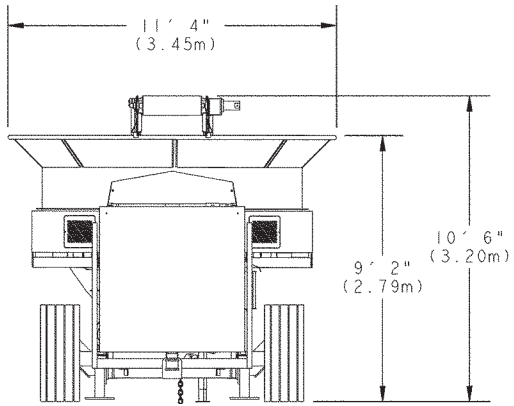
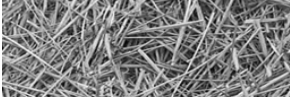
Rotor - Std No. of Hammers ..... 88  
 Hammer Size .....2-1/2 x 7-3/4 x 1/2 (6 cm x 20 cm x 1 cm)  
 Rotor - Shaft diameter ..... 3-1/2 in. (9 cm) stress proof steel  
 Rotor Size .....50 in. long, 26 in. diameter with hammers extended  
 Screen Area ..... 2,781 sq. in. (17,942 sq. cm.)  
 Screens Available (inches) ..... 1/8, 3/16, 1/4, 3/8, 1/2, 5/8, 3/4, 1,  
 1-1/2, 2, 3, 4,5, 6, 7, 8 Round holes. 2,3,4 Slotted Holes

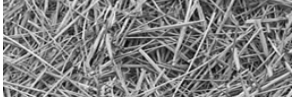
Feed Delivery ..... 26 ft. folding rubber belt conveyor w/cleats 24 in. Wide  
 Tub size ..... 107 in. (272 cm) ID  
 Tub Depth .....50 in. (127 cm)  
 Tub Drive ..... Electro-Hydraulic

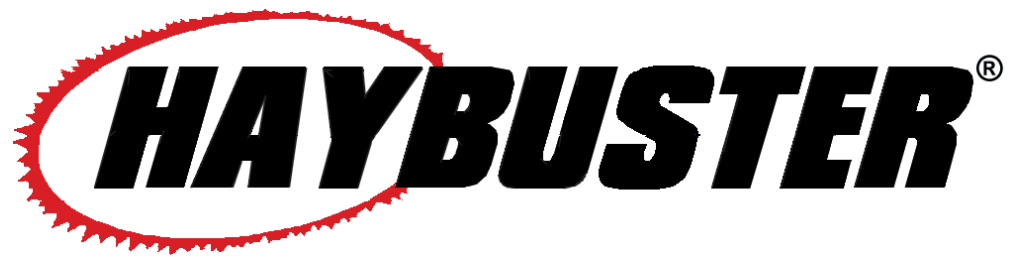
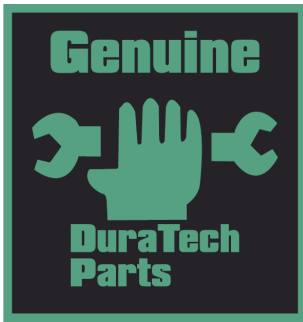
## Options

AVAILABLE OPTIONS FOR DURATECH INDUSTRIES H-1130 TUB GRINDER:

- Ear Corn Kit
- Geysers Plate
- Grain Grinding Hopper
- Mill Grate / Slugbar Combination
- Various Screens Sizes
- Material Guide





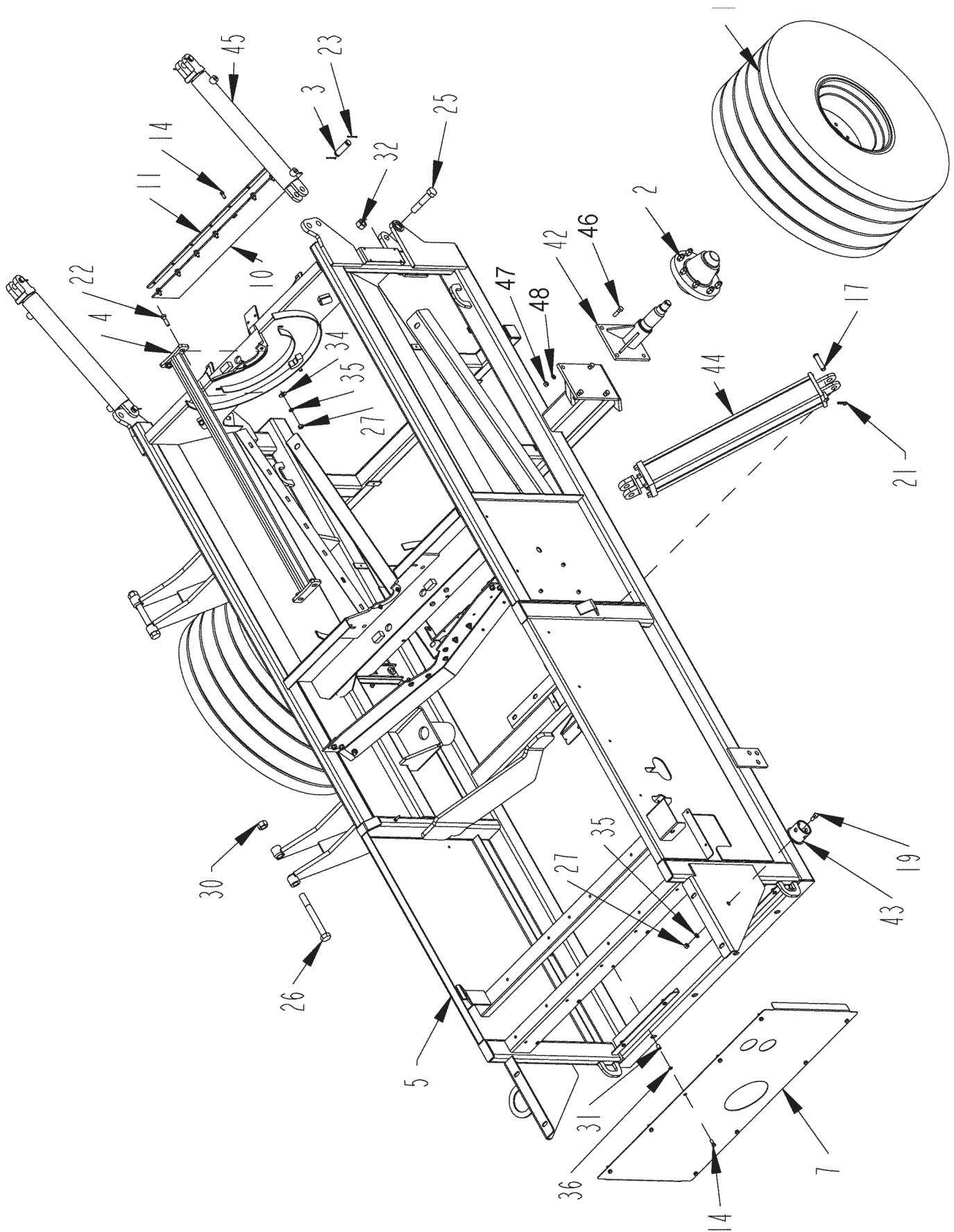


# **H-1130<sup>TM</sup>**

## **PTO Driven Tub Grinder**

### **Part 2: Parts Reference**

MAINFRAME ASSEMBLY #1 (S.N. UP TO 1110009530)



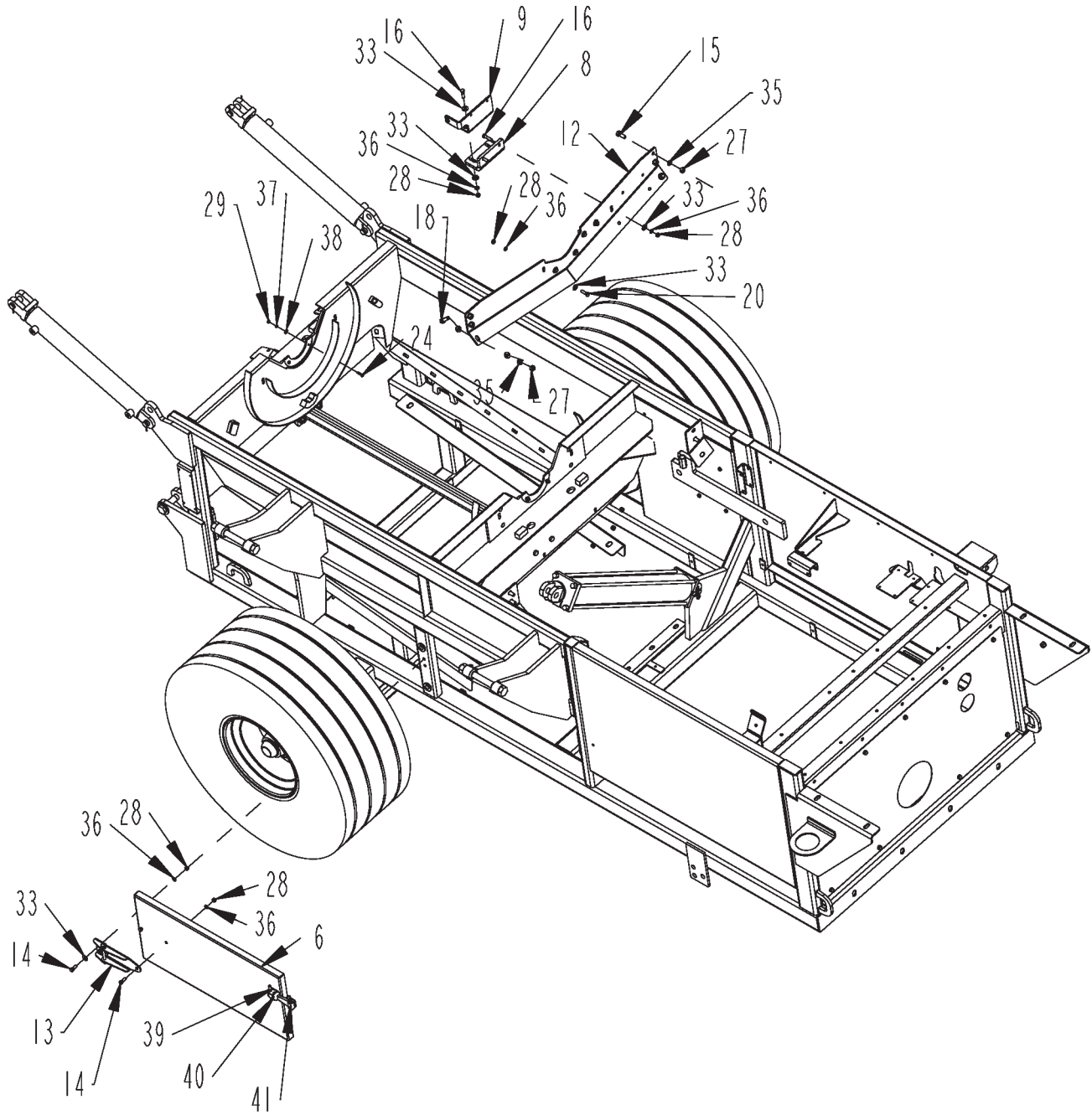
**MAINFRAME ASSEMBLY #1 (S.N. UP TO 1110009530)**

ITEM	PART	QTY.	PART DESCRIPTION
1	2600861	2	WHL\ASSY\16.5SLX16.1X14PLY8BOLT-WHL\16.1X14\3/8POS (SEE WHEELS AND HUBS)
2	2900140	2	HUB\ASSY\H817\8BOLT\8"B.C.\6"PILOT (SEE WHEELS AND HUBS)
3	4100030	4	PIN 1" X 3-1/2" HYD. CYL.
4	4501838	1	GUIDE\SCRN
5	4502300	1	FRM\MAIN\H1100SS
6	4502336	1	DOOR\ACCESSITNSNR
7	4502345	1	CVR\FR\GRNDR
8	4502405	1	PL\MNT\PKP\SPD
9	4502421	1	BRCKT\MNT\PKP\SPD
10	4502430	1	BELT\SEAL\TRNSTN\CNVYR
11	4502431	1	STRP\RET\BLT
12	4502439	1	ANGL\CRSS\FRMMID
13	4703579	1	HINGE\ASSY\FAB\3-1/2
14	4800003	20	BOLT\HEX\3/8X1
15	4800018	4	BOLT\HEX\1/2X1-1/4
16	4800034	4	BOLT\HEX\3/8X1-1/2
17	4800046	1	PIN\CLEVIS\3/4X3
18	4800082	4	BOLT\HEX\1/2X1-1/2
19	4800085	1	BOLT\HEX\1/2X1
20	4800098	4	BOLT\HEX\3/8X1-1/4\NC
21	4800107	1	PIN\HAIR\1/8(#9)
22	4800178	2	BOLT\HEX\1/2X1-3/4
23	4800203	8	PIN\COT\5/32X2
24	4800277	4	BOLT\HEX\1/4X1
25	4800546	2	BOLT\HEX\1X5\NC
26	4800601	2	BOLT\HEX\1X9\NC
27	4900001	11	NUT\HEX\1/2\NC
28	4900002	12	NUT\HEX\3/8\NC
29	4900009	4	NUT\HEX\1/4\NC
30	4900015	2	NUT\NYLCK\1\NC
31	4900082	9	NUT\INSERT\3/8\0.027X.150GR
32	4900127	2	NUT\PLCK\1\NC
33	5000001	20	WASH\FLAT\3/8
34	5000004	4	WASH\FLAT\1/2
35	5000006	11	WASH\LOCK\1/2
36	5000019	21	WASH\LOCK\3/8
37	5000024	4	WASH\LOCK\1/4
38	5000035	4	WASH\FLAT\1/4
39	7500166	1	LATCH\RBBR\6
40	7500190	1	LATCH\RBBR\CATCH\6
41	7500347	1	LATCH\RBBR\MNT\6
42	8101600	2	SPNDL\2800
43	8101748	1	BRKT\STRG\JACK
44	4100144	1	CYL\HYD\4X30\1-3/4 ROD\CLEVIS ENDS\O-RING PORTS
45	4100261	2	CYL\HYD\3X20\1-1/2ROD
46	4800010	8	BOLT\HEX\5/8X2
47	4900005	8	NUT\HEX\5/8\NC
48	5000003	8	WASH\LOCK\5/8

**NOT SHOWN**

3700961	1	HOSE\LUB\1/8X40\MPS-MPS
3700962	1	HOSE\LUB\1/8X48\MPS-MPS
3700963	1	HOSE\LUB\1/8X34\MPS-MPS
7501068	2	GRMT\RBBR\3-5/8X3IDX3/8T

**MAINFRAME ASSEMBLY #2 (S.N. UP TO 1110009530)**



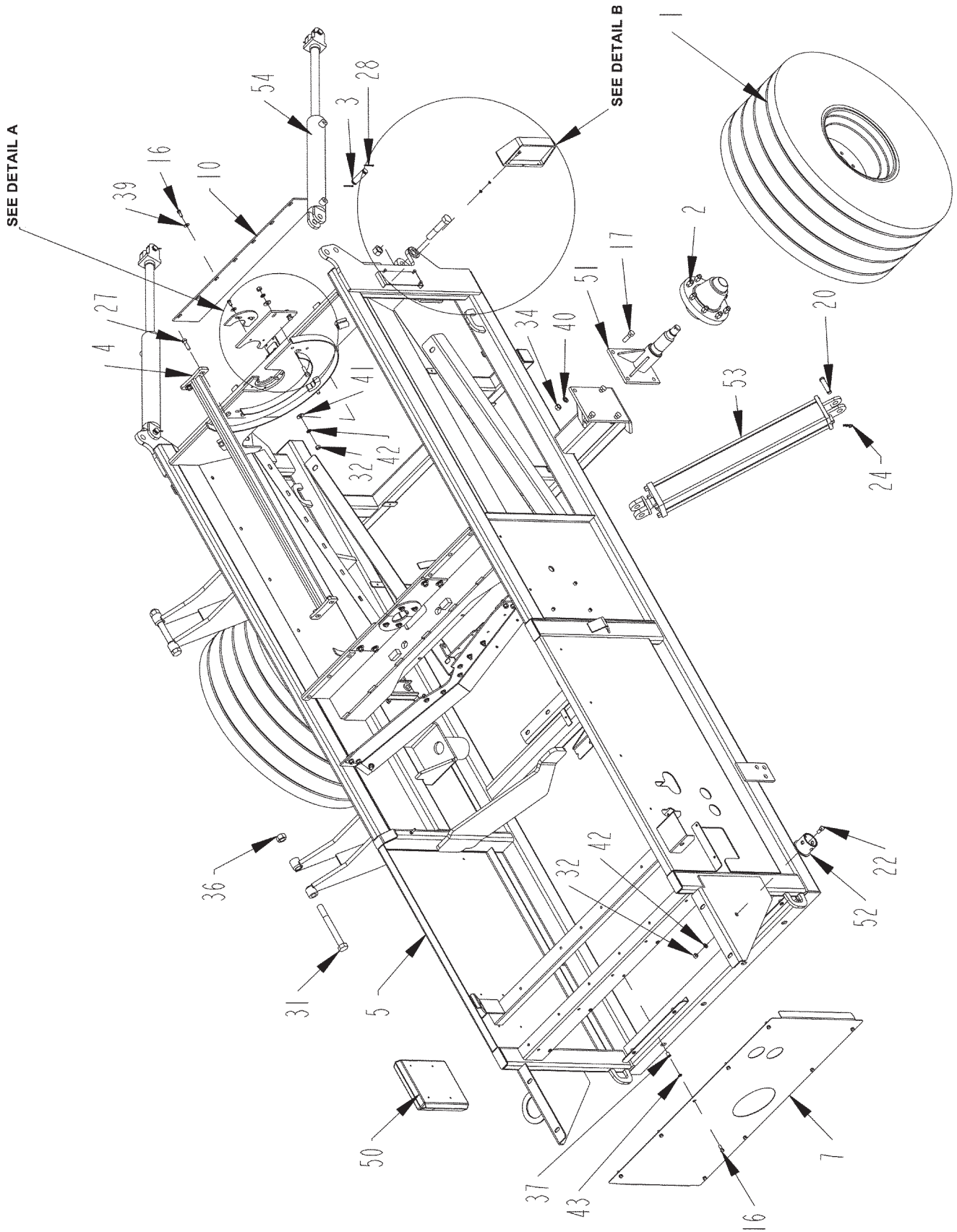
**MAINFRAME ASSEMBLY #2 (S.N. UP TO 1110009530)**

ITEM	PART	QTY.	PART DESCRIPTION
1	2600861	2	WHL\ASSY\16.5SLX16.1X14PLY8BOLT-WHL\16.1X14\3/8POS <b>(SEE WHEELS AND HUBS)</b>
2	2900140	2	HUB\ASSY\H817\8BOLT\8"B.C.\6"PILOT <b>(SEE WHEELS AND HUBS)</b>
3	4100030	4	PIN 1" X 3-1/2" HYD. CYL.
4	4501838	1	GUIDE\SCRN
5	4502300	1	FRM\MAIN\H1100SS
6	4502336	1	DOOR\ACCESS\TNSNR
7	4502345	1	CVR\FR\GRNDR
8	4502405	1	PL\MNT\PKP\SPD
9	4502421	1	BRCKT\MNT\PKP\SPD
10	4502430	1	BELT\SEAL\TRNSTN\CNVYR
11	4502431	1	STRP\RET\BLT
12	4502439	1	ANGL\CROSS\FRM\MID
13	4703579	1	HINGE\ASSY\FAB\3-1/2
14	4800003	20	BOLT\HEX\3/8X1
15	4800018	4	BOLT\HEX\1/2X1-1/4
16	4800034	4	BOLT\HEX\3/8X1-1/2
17	4800046	1	PIN\CLEVIS\3/4X3
18	4800082	4	BOLT\HEX\1/2X1-1/2
19	4800085	1	BOLT\HEX\1/2X1
20	4800098	4	BOLT\HEX\3/8X1-1/4\NC
21	4800107	1	PIN\HAIR\1/8(#9)
22	4800178	2	BOLT\HEX\1/2X1-3/4
23	4800203	8	PIN\COT\5/32X2
24	4800277	4	BOLT\HEX\1/4X1
25	4800546	2	BOLT\HEX\1X5\NC
26	4800601	2	BOLT\HEX\1X9\NC
27	4900001	11	NUT\HEX\1/2\NC
28	4900002	12	NUT\HEX\3/8\NC
29	4900009	4	NUT\HEX\1/4\NC
30	4900015	2	NUT\NYLCK\1\NC
31	4900082	9	NUT\INSERT\3/8\027X.150GR
32	4900127	2	NUT\PLCK\1\NC
33	5000001	20	WASH\FLAT\3/8
34	5000004	4	WASH\FLAT\1/2
35	5000006	11	WASH\LOCK\1/2
36	5000019	21	WASH\LOCK\3/8
37	5000024	4	WASH\LOCK\1/4
38	5000035	4	WASH\FLAT\1/4
39	7500166	1	LATCH\RBBR\6
40	7500190	1	LATCH\RBBR\CATCH\6
41	7500347	1	LATCH\RBBR\MNT\6
42	8101600	2	SPNDL\2800
43	8101748	1	BRKT\STRG\JACK
44	4100144	1	CYL\HYD\4X30\1-3/4 ROD\CLEVIS ENDS\O-RING PORTS
45	4100261	2	CYL\HYD\3X20\1-1/2ROD
46	4800010	8	BOLT\HEX\5/8X2
47	4900005	8	NUT\HEX\5/8\NC
48	5000003	8	WASH\LOCK\5/8

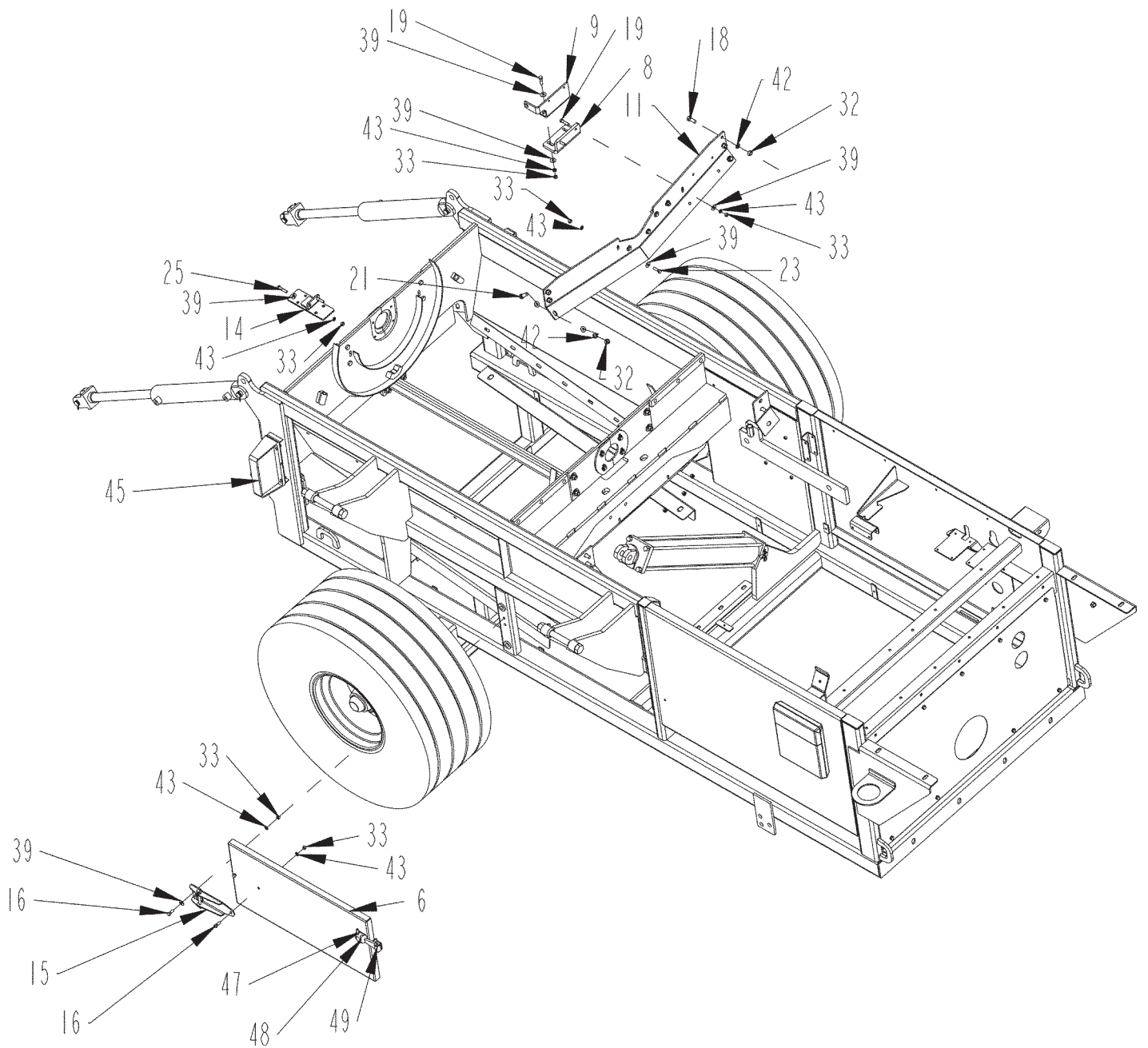
**NOT SHOWN**

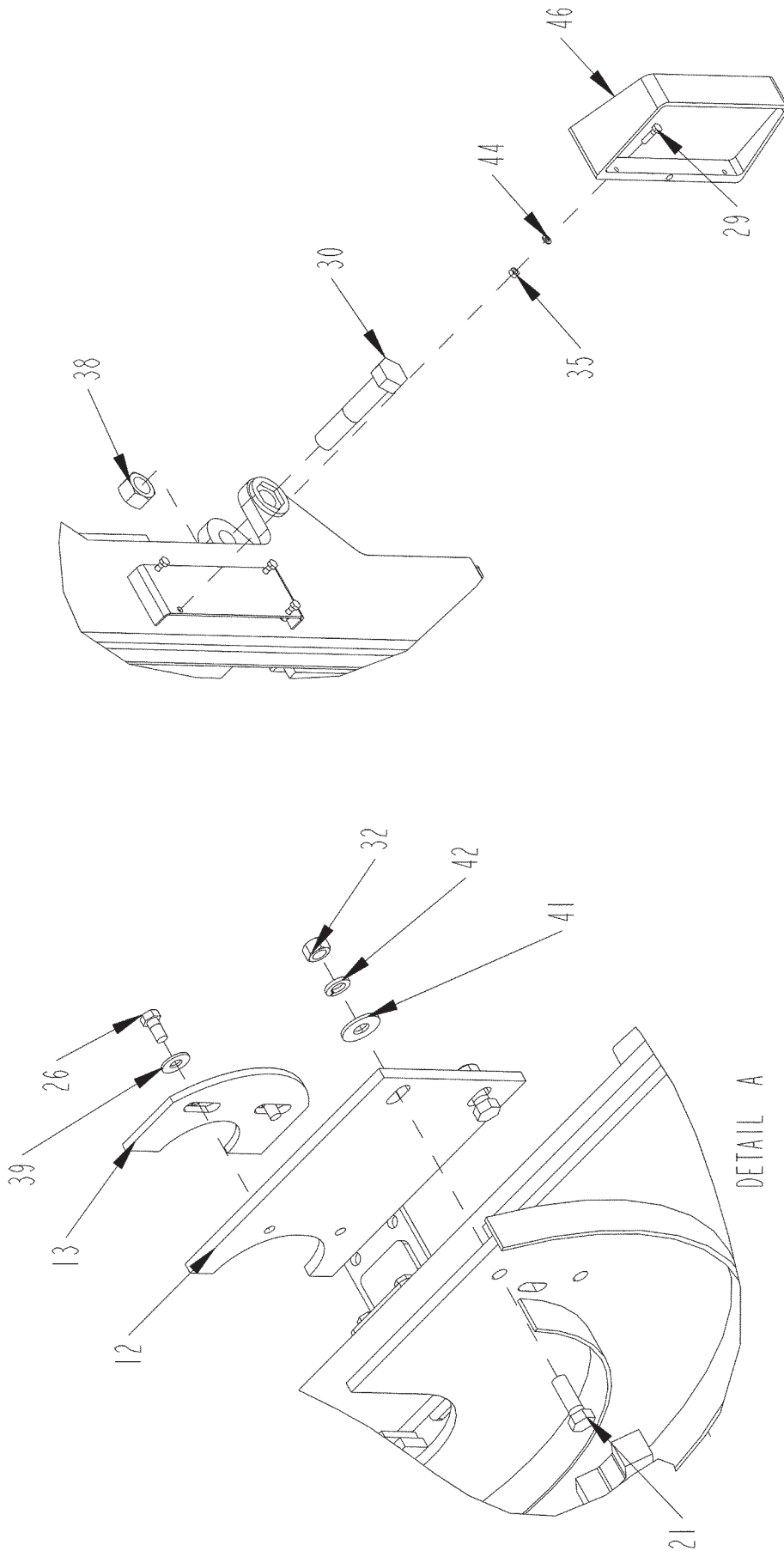
3700961	1	HOSE\LUB\1/8X40\MPS-MPS
3700962	1	HOSE\LUB\1/8X48\MPS-MPS
3700963	1	HOSE\LUB\1/8X34\MPS-MPS
7501068	2	GRMT\RBBR\3-5/8X3IDX3/8T

MAINFRAME ASSEMBLY #1 (S.N. 1110009630 THRU 111125030)



**MAINFRAME ASSEMBLY #2 (S.N. 111009630 THRU 111125030)**





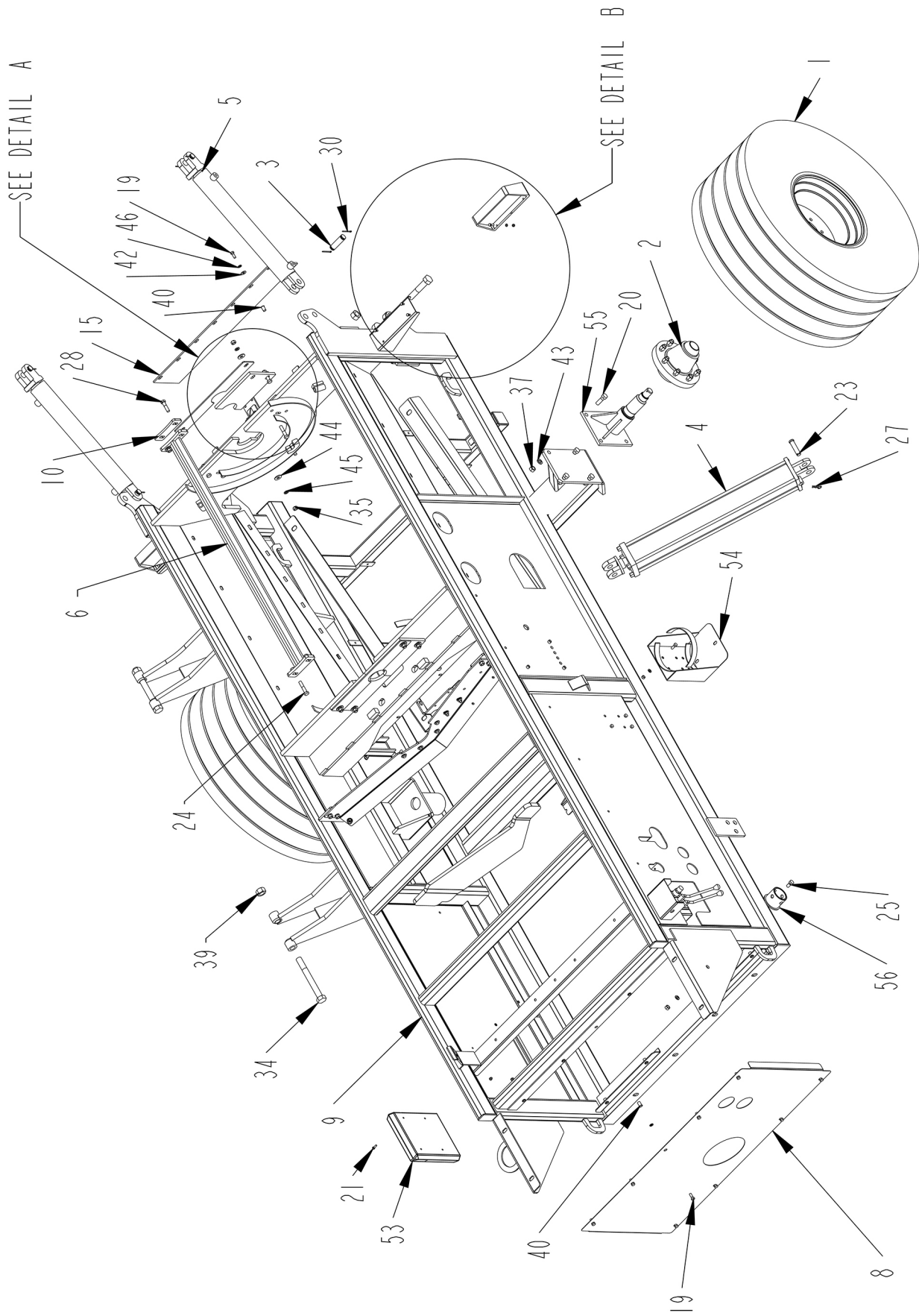
DETAIL B

DETAIL A

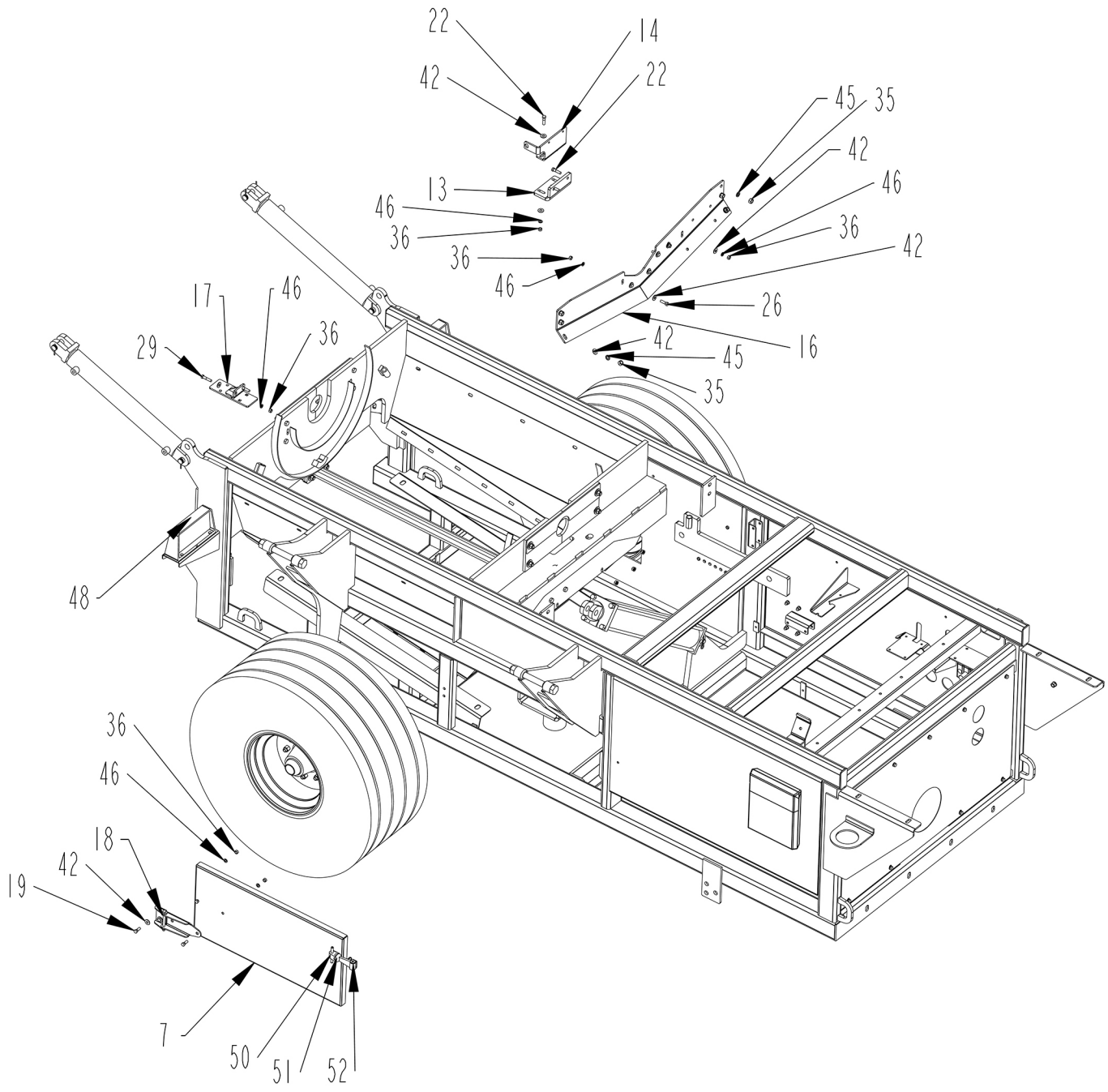
**MAINFRAME ASSEMBLY (S.N. 1110009630 THRU 111125030)**

<b>ITEM</b>	<b>PART</b>	<b>QTY.</b>	<b>PART DESCRIPTION</b>
1	2600861	2	WHL\ASSY\16.5SLX16.1X14PLY8BOLT-WHL\16.1X14\3/8POS (SEE WHEELS AND HUBS)
2	2900140	2	HUB\ASSY\H817\8BOLT\8"B.C.\6"PILOT (SEE WHEELS AND HUBS)
3	4100030	4	PIN 1" X 3-1/2" HYD. CYL.
4	4501838	1	GUIDE\SCRN
5	4502300	1	FRMMAIN\H1100SS
6	4502336	1	DOOR\ACCESSITNSNR
7	4502345	1	CVR\FR\GRNDR
8	4502405	1	PL\MNT\PKP\SPD
9	4502421	1	BRCKT\MNT\PKP\SPD
10	4502430	1	BELT\SEAL\TRNSTN\CNVYR
11	4502439	1	ANGL\CRSS\FRMMID
12	4502615	4	PL\SEAL\ADJ\SHFT\RTR
13	4502616	4	SEAL\SHAFT\3-1/4\RTR\NYLN
14	4502619	1	MNT\MNF\LD\HOSE\HYD
15	4703579	1	HINGE\ASSY\FAB\3-1/2
16	4800003	20	BOLT\HEX\3/8X1
17	4800010	8	BOLT\HEX\5/8X2
18	4800018	4	BOLT\HEX\1/2X1-1/4
19	4800034	4	BOLT\HEX\3/8X1-1/2
20	4800046	1	PIN\CLEVIS\3/4X3
21	4800082	10	BOLT\HEX\1/2X1-1/2
22	4800085	1	BOLT\HEX\1/2X1
23	4800098	4	BOLT\HEX\3/8X1-1/4\NC
24	4800107	1	PIN\HAIR\1/8(#9)
25	4800142	2	BOLT\HEX\3/8X1-3/4
26	4800164	8	BOLT\HEX\3/8X3/4
27	4800178	2	BOLT\HEX\1/2X1-3/4
28	4800203	8	PIN\COT\5/32X2
29	4800277	8	BOLT\HEX\1/4X1
30	4800546	2	BOLT\HEX\1X5\NC
31	4800601	2	BOLT\HEX\1X9\NC
32	4900001	19	NUT\HEX\1/2\NC
33	4900002	14	NUT\HEX\3/8\NC
34	4900005	8	NUT\HEX\5/8\NC
35	4900009	8	NUT\HEX\1/4\NC
36	4900015	2	NUT\NYLCK\1\NC
37	4900082	9	NUT\INSERT\3/8\027X.150GR
38	4900127	2	NUT\PLCK\1\NC
39	5000001	37	WASH\FLAT\3/8
40	5000003	8	WASH\LOCK\5/8
41	5000004	12	WASH\FLAT\1/2
42	5000006	19	WASH\LOCK\1/2
43	5000019	31	WASH\LOCK\3/8
44	5000024	8	WASH\LOCK\1/4
45	5700715	1	TAILLIGHT\RED;RIGHT\ASSY\4PIN
45LED	5701058		TAILLIGHT\RED;RIGHT\LED\ASSY\4PIN
46	5700716	1	TAILLIGHT\RED;LEFT\ASSY\4PIN
46LED	5701059		TAILLIGHT\RED;LEFT\LED\ASSY\4PIN
47	7500166	1	LATCH\RB\BR\6
48	7500190	1	LATCH\RB\BR\CATCH\6
49	7500347	1	LATCH\RB\BR\MNT\6
50	7500590	1	ENCL\OPS\8-1/2X11X1-5/8
51	8101600	2	SPNDL\2800
52	8101748	1	BRKT\STRG\JACK
53	4100144	1	CYL\HYD\4X30\1-3/4 ROD\CLEVIS ENDS\O-RING PORTS
54	4100261	2	CYL\HYD\3X20\1-1/2ROD
<b>NOT SHOWN</b>			
	3700961	1	HOSE\LUB\1/8X40\MPS-MPS
	3700962	1	HOSE\LUB\1/8X48\MPS-MPS
	3700963	1	HOSE\LUB\1/8X34\MPS-MPS
	7501068	2	GRMT\RB\BR\3-5/8X3ID\3/8T

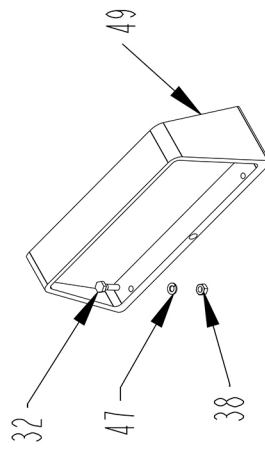
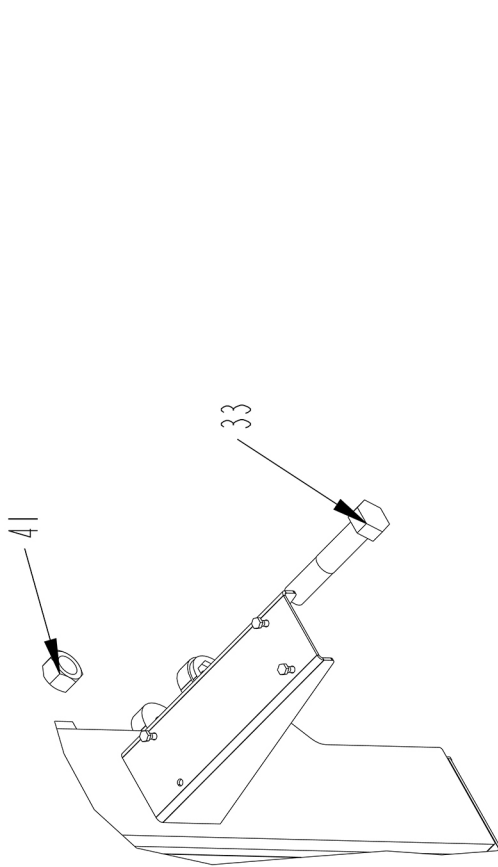
MAINFRAME ASSEMBLY #1 (S.N. 1112025130 & UP)



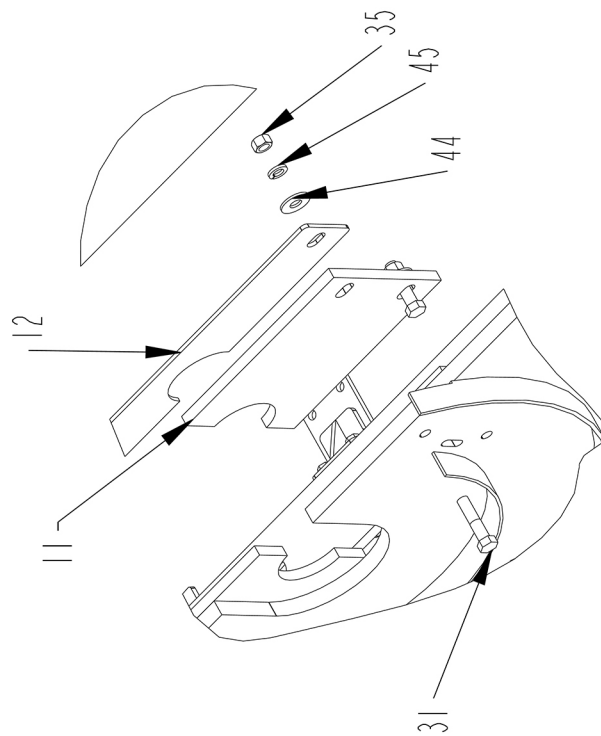
**MAINFRAME ASSEMBLY #2 (S.N. 1112025130 & UP)**



MAINFRAME ASSEMBLY DETAILS A & B (S.N. 1112025130 & UP)



DETAIL B

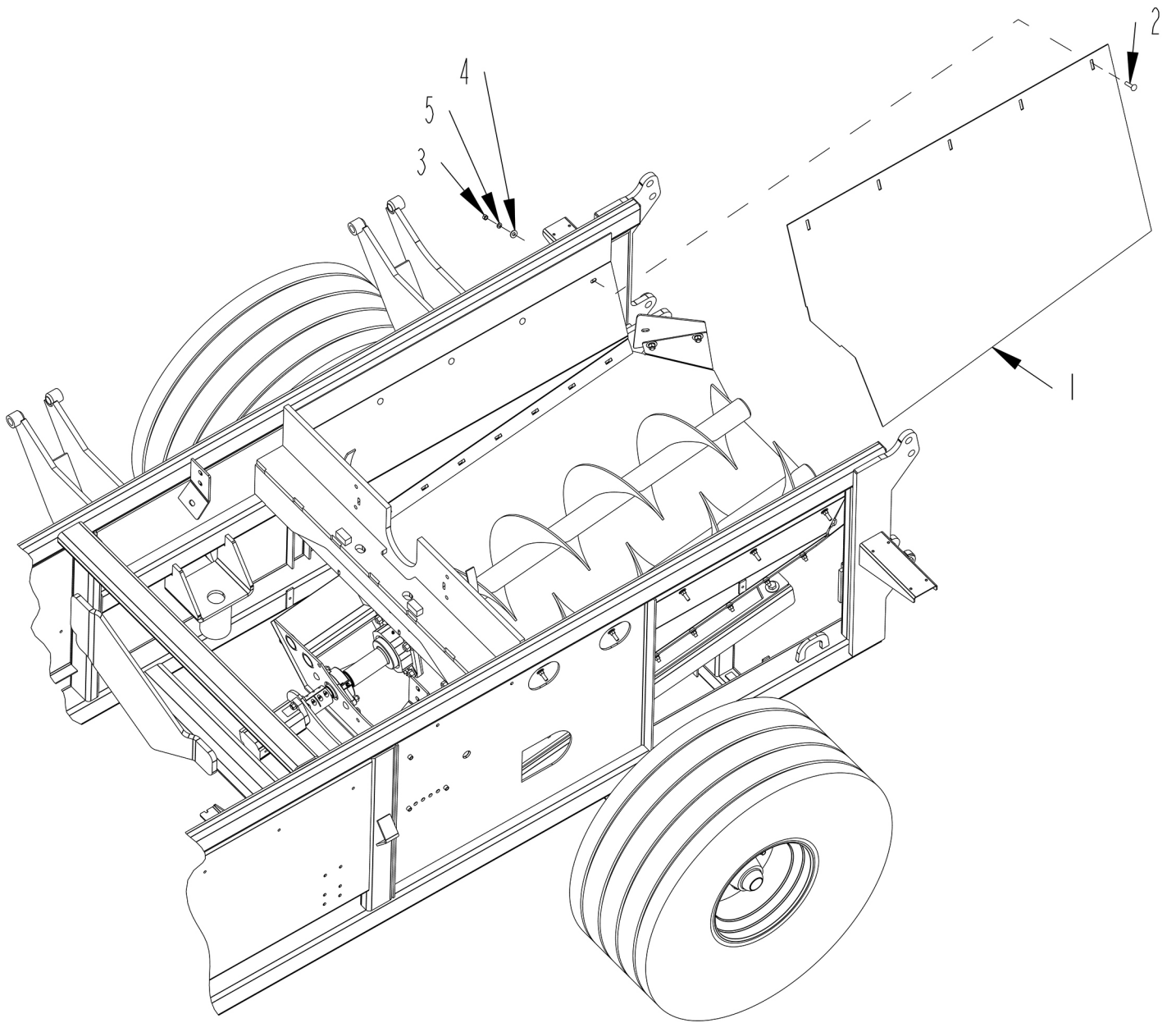


DETAIL A

**MAINFRAME ASSEMBLY (S.N. 1112025130 & UP)**

ITEM	PART	QTY.	PART DESCRIPTION
1	2600861	2	WHL\ASSY\16.5SLX16.1X14PLY8BOLT-WHL\16.1X14\3/8POS <b>(SEE WHEELS AND HUBS)</b>
2	2900140	2	HUB\ASSY\H817\8BOLT\8"B.C.16"PILOT <b>(SEE WHEELS AND HUBS)</b>
3	4100030	4	PIN 1" X 3-1/2" HYD. CYL.
4	4100144	1	CYL\HYD\4X30\1-3/4 ROD\CLEVIS ENDS\O-RING PORTS
5	4100261	2	CYL\HYD\3X20\1-1/2ROD - CANADIAN TOOL & DIE
5A	4100328		CYL\HYD\3X20\1-1/2ROD -RAM INDUSTRIES
6	4501838	1	GUIDE\SCRN
7	4502336	1	DOOR\ACCESS\TNSNR
8	4502345	1	CVR\FR\GRNDR
9	4502382	1	FRM\MAIN\H1130 <b>(FOR SN UP TO 1115065030)</b>
9A	4502664	1	FRM\MAIN\H1130 <b>(FOR SN 1115065130 &amp; UP)</b>
10	4502386	1	SPCR\GUIDE\SCRN
11	4502391	4	SEAL\RTR
12	4502392	2	CVR\SEAL\RTR
13	4502405	1	PL\MNT\PKP\SPD
14	4502421	1	BRCKT\MNT\PKP\SPD
15	4502430	1	BELT\SEAL\TRNSTN\CNVYR
16	4502439	1	ANGL\CRSS\FRMMID
17	4502619	1	MNT\MNFLD\HOSE\HYD
18	4703579	1	HINGE\ASSY\FAB\3-1/2
19	4800003	24	BOLT\HEX\3/8X1
20	4800010	8	BOLT\HEX\5/8X2
21	4800024	4	BOLT\HEX\1/4X3/4
22	4800034	4	BOLT\HEX\3/8X1-1/2
23	4800046	1	PIN\CLEVIS\3/4X3
24	4800070	2	BOLT\HEX\1/2X2-1/2
25	4800085	1	BOLT\HEX\1/2X1
26	4800098	4	BOLT\HEX\3/8X1-1/4\NC
27	4800107	1	PIN\HAIR\1/8(#9)
28	4800114	2	BOLT\HEX\1/2X2
29	4800142	2	BOLT\HEX\3/8X1-3/4
30	4800203	8	PIN\COT\5/32X2
31	4800251	8	BOLT\HEX\1/2X2-1/4\NC
32	4800277	8	BOLT\HEX\1/4X1
33	4800546	2	BOLT\HEX\1X5\NC
34	4800601	2	BOLT\HEX\1X9\NC
35	4900001	19	NUT\HEX\1/2\NC
36	4900002	18	NUT\HEX\3/8\NC
37	4900005	8	NUT\HEX\5/8\NC
38	4900009	12	NUT\HEX\1/4\NC
39	4900015	2	NUT\NYLCK\1\NC
40	4900083	16	NUT\INSERT\3/8\LONG\0.15-0.312\(.418/CD)
41	4900127	2	NUT\TPLCK\1\NC
42	5000001	23	WASH\FLAT\3/8
43	5000003	8	WASH\LOCK\5/8
44	5000004	12	WASH\FLAT\1/2
45	5000006	19	WASH\LOCK\1/2
46	5000019	34	WASH\LOCK\3/8
47	5000024	12	WASH\LOCK\1/4
48	5700715	1	TAILLIGHT\RED;RIGHT\ASSY\4PIN
48LED	5701058		TAILLIGHT\RED;RIGHT\LED\ASSY\4PIN
49	5700716	1	TAILLIGHT\RED;LEFT\ASSY\4PIN
49LED	5701059		TAILLIGHT\RED;LEFT\LED\ASSY\4PIN
50	7500166	1	LATCH\RBBR\6
51	7500190	1	LATCH\RBBR\CATCH\6
52	7500347	1	LATCH\RBBR\MNT\6
53	7500590	1	ENCL\OPS\8-1/2X11X1-5/8
54	7500853	1	BRKT\EXTINGUISHER\20LB
55	8101600	2	SPNDL\2800
56	8101748	1	BRKT\STRG\JACK
<b>NOT SHOWN</b>			
	3700961	1	HOSE\LUB\1/8X40\MPS-MPS <b>(BULL WHEEL)</b>
	3700962	1	HOSE\LUB\1/8X48\MPS-MPS <b>(ROTOR)</b>
	3700963	1	HOSE\LUB\1/8X34\MPS-MPS <b>(BULL WHEEL)</b>
	7501068	2	GRMT\RBBR\3-5/8X3\DX\3/8T

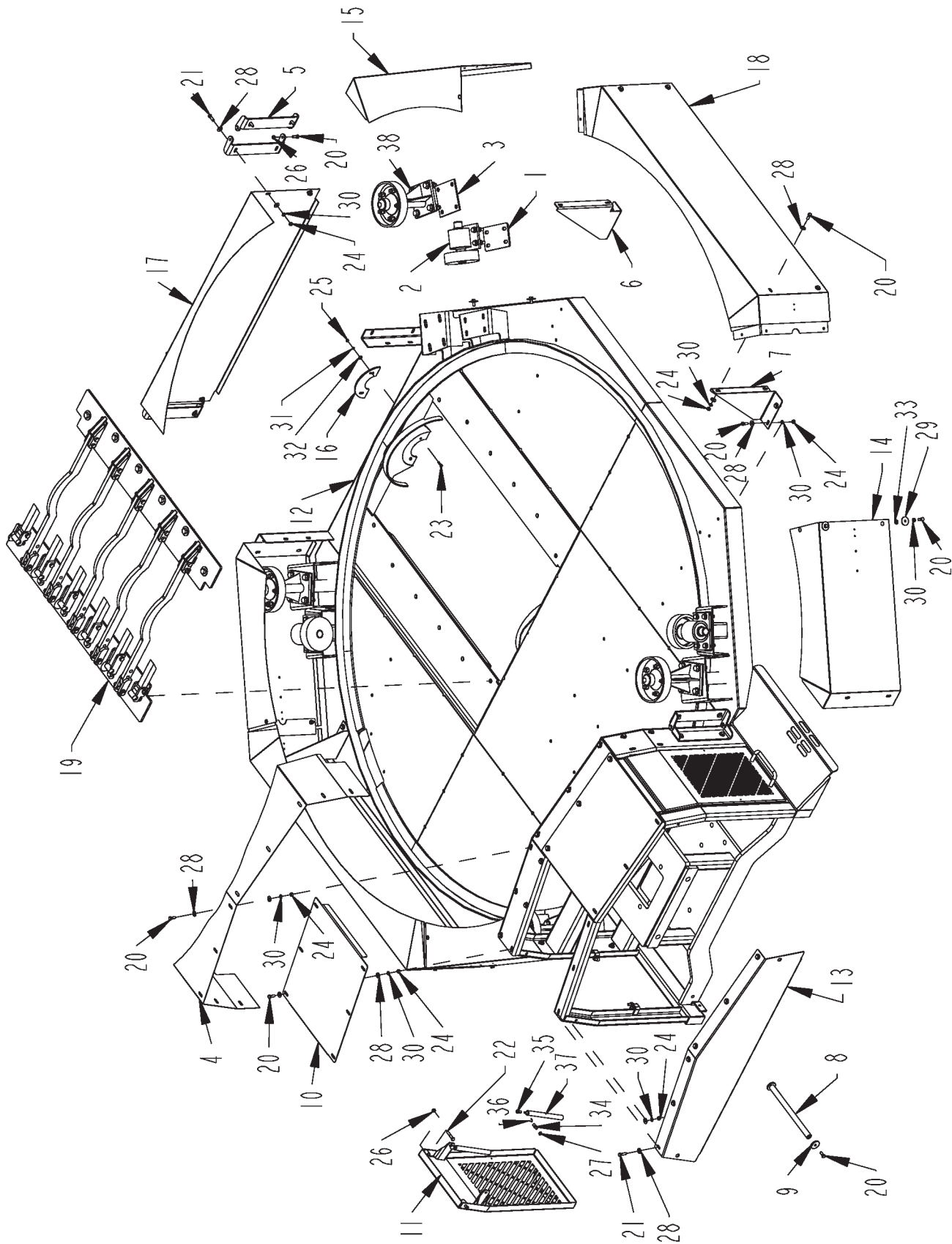
**BELLY SIDE SHEETS**



## BELLY SIDE SHEETS

ITEM	PART	QTY.	PART DESCRIPTION
1	4502295	2	SH\SIDE\BELLY
2	4800168	10	BOLT\CRG\3/8X1-3/4\NC
3	4900002	10	NUT\HEX\3/8\NC
4	5000001	10	WASH\FLAT\3/8
5	5000019	10	WASH\LOCK\3/8

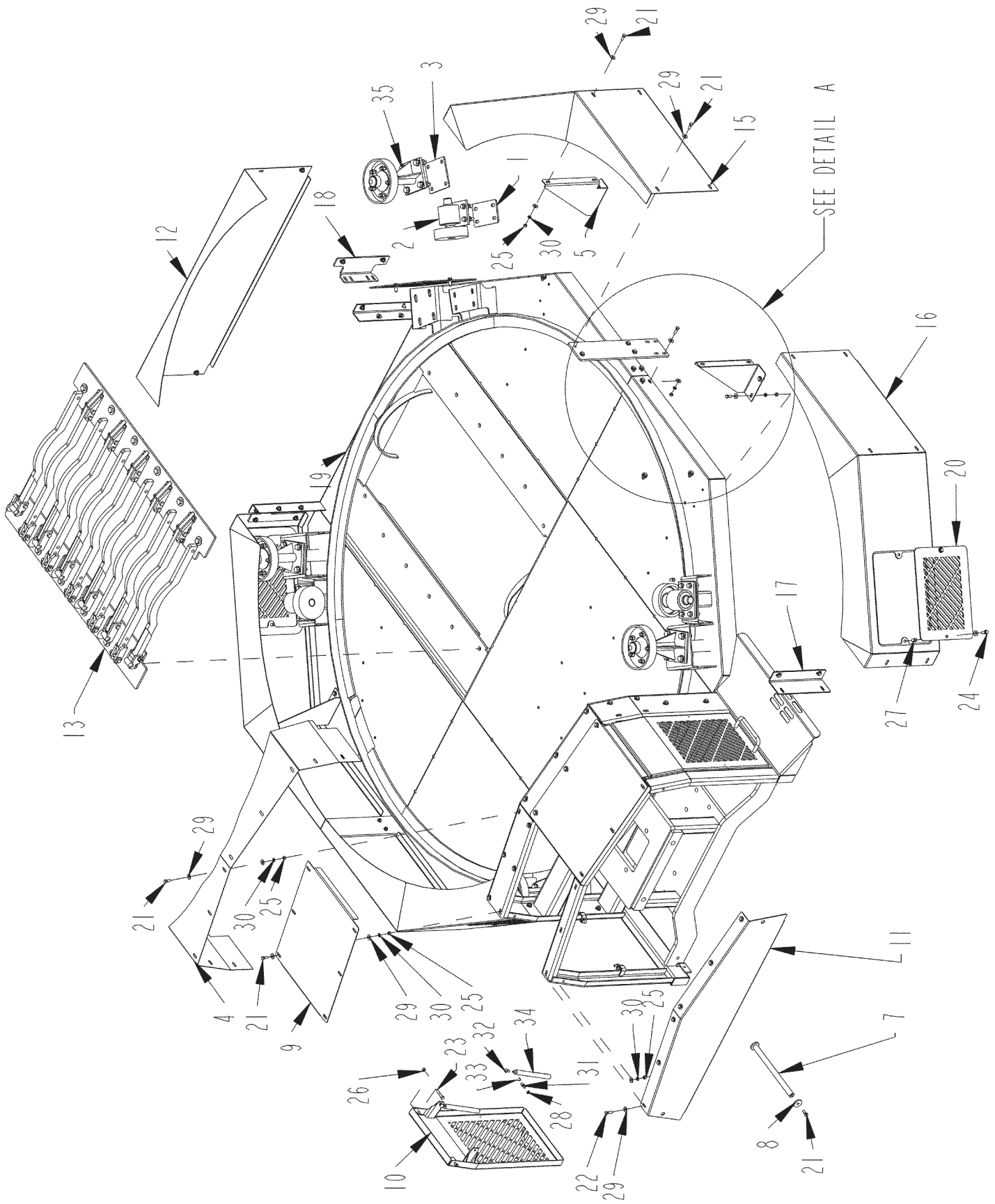
PLATFORM ASSEMBLY (S.N. UP TO 1110009530)



**PLATFORM ASSEMBLY (S.N. UP TO 1110009530)**

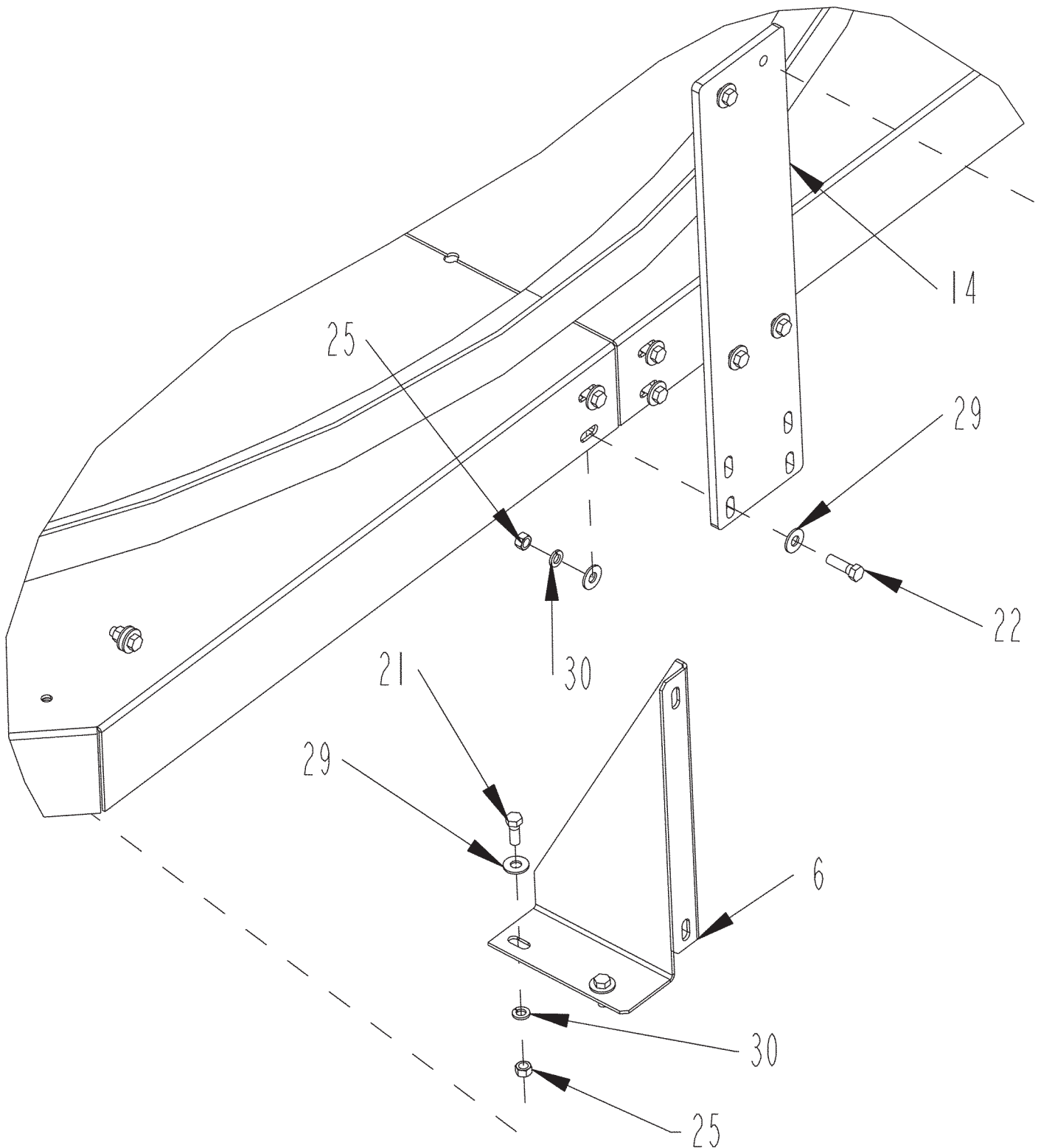
<b>ITEM</b>	<b>PART</b>	<b>QTY.</b>	<b>PART DESCRIPTION</b>
1	4501131	4	SHIM\RLLR\SPPRT\TUB
2	4702007	4	BRG\PB\RLLR\TUB\ASYW\BRG
3	4501476	4	SHIM\RLLR\PRESS
4	4501518	1	SHLD\DRIVE\TUB
5	4501700	8	BRKT\SHLD\RLLR\TUB
6	4501915	2	BRKT\SHLD\CHAIN\DRIVE\TUB
7	4501916	2	BRKT\SHLD\CHAIN\DRIVE\TUB
8	4501931	1	PIN\PLFRM\TILTCYL
9	4501932	2	WASH\1-3/4 O.D.
10	4502088	2	CVR\DRV\TUB
11	4502089	2	DOOR\DRV\TUB
12	4502347	1	FRM\PLFRM\TILT\H1100\RTR\REAR
13	4502401	1	CVR\FR\FRMMN
14	4502403	2	SHLD\DRV\TUB\FR\LFT
15	4502404	2	SHLD\DRIVE\TUB\RH\FR
16	4502413	2	SEAL\SHAFT\3-1/4\RTR
17	4502422	1	SHLD\DRV\CHAIN\TUB\REAR
18	4502423	2	SHLD\DRIVE\TUB\SIDE
19	4502436	1	GRATE\MILLW\SLGBSTRS
20	4800003	54	BOLT\HEX\3/8X1
21	4800098	18	BOLT\HEX\3/8X1-1/4\NC
22	4800146	4	BOLT\HEX\3/8X2
23	4800277	4	BOLT\HEX\1/4X1
24	4900002	54	NUT\HEX\3/8\NC
25	4900009	4	NUT\HEX\1/4\NC
26	4900023	12	NUT\TPLCK\3/8\NC
27	4900142	8	NUT\TPLCK\5/16\NC
28	5000001	100	WASH\FLAT\3/8
29	5000017	8	WASH\FLAT\FNDR\395X1-5/8X.090
30	5000019	62	WASH\LOCK\3/8
31	5000024	4	WASH\LOCK\1/4
32	5000035	4	WASH\FLAT\1/4
33	5000135	8	WASH\RTNR\BLT\3/8\781OD
34	7500664	8	BALL STUD\SHOCK\FITTING\M6
35	7500665	8	END FITTING\GAS SPRING \m6
36	7500666	8	SAFETY CLIP
37	7500680	4	SPRNG\GAS\60LB\9416K174
38	4500247	4	RLLR\PRESS\COMPL
	<b>4502348</b>		<b>PLTFRM\ASSY\SUB\H1130</b>
	<b>NOT SHOWN</b>		
	4800468	4	SCR\RD\SLOT\#10-24X1/2\NC
	4900077	4	NUT\HEX\#10\NF
	5000071	4	WASH\LOCK\EXT\STAR\#10
	7500756	4	BMPR\RBBR\1-1/32X5/8

PLATFORM ASSEMBLY (S.N. 1110009630 TO 1115070030)



**PLATFORM ASSEMBLY (S.N. 1110009630 TO 1115070030)**

<b>ITEM</b>	<b>PART</b>	<b>QTY.</b>	<b>PART DESCRIPTION</b>
1	4501131	4	SHIM\RLLR\SPPRT\TUB
2	4704069	4	RLLR\TUB\ASSY\STEEL\CAST
3	4501476	4	SHIM\RLLR\PRESS
4	4501518	1	SHLD\DRIVE\TUB
5	4501915	2	BRKT\SHLD\CHAIN\DRIVE\TUB
6	4501916	2	BRKT\SHLD\CHAIN\DRIVE\TUB
7	4501931	1	PIN\PLFRM\TILT\CYL
8	4501932	2	WASH\1-3/4 O.D.
9	4502088	2	CVR\DRV\TUB
10	4502089	2	DOOR\DRV\TUB
11	4502401	1	CVR\FR\FRMMN
12	4502422	1	SHLD\DRV\CHAIN\TUB\REAR
13	4502436	1	GRATE\MILLW\SLGBSTRS
14	4502631	2	SPPRT\SHLD\SD\TUB
15	4502663	2	SHLD\TUB\LR\F
16	4502662	2	SHLD\TUB\LF\RR
17	4502640	2	MNT\SHLD\TUB\FR
18	4502641	2	MNT\SHLD\TUB\REAR
19	4502642	1	FRM\PLFRM\TILT\1130\RTR\REAR
20	4703727	4	DOOR\SHLD\TUB
21	4800003	57	BOLT\HEX\3/8X1
22	4800098	14	BOLT\HEX\3/8X1-1/4\NC
23	4800146	4	BOLT\HEX\3/8X2
24	4800914	8	BOLT\FLG\SERR\3/8X1-1/4\NC
25	4900002	66	NUT\HEX\3/8\NC
26	4900023	4	NUT\TPLCK\3/8\NC
27	4900083	8	NUT\INSERT\3/8\LONG\0.15-0.312\(.418/CD)
28	4900142	8	NUT\TPLCK\5/16\NC
29	5000001	140	WASH\FLAT\3/8
30	5000019	66	WASH\LOCK\3/8
31	7500664	8	BALL STUD\SHOCK\FITTING\M6
32	7500665	8	END FITTING\GAS SPRING \m6
33	7500666	8	SAFETY CLIP
34	7500680	4	SPRNG\GAS\60LB\9416K174
35	4500247	4	RLLR\PRESS\COMPL
	<b>4502348</b>		<b>PLFRM\ASSY\SUB\H1130</b>
	<b>NOT SHOWN</b>		
	4500737	1	STOP\CYL\PLFRM
	4800046	1	PIN\CLEVIS\3/4X3
	4800107	1	PIN\HAIR\1/8(#9)
	4800468	4	SCR\RD\SLOT\#10-24X1/2\NC
	4900077	4	NUT\HEX\#10\NF
	5000071	4	WASH\LOCK\EXT\STAR\#10
	7500756	4	BMPR\RBBR\1-1/32X5/8

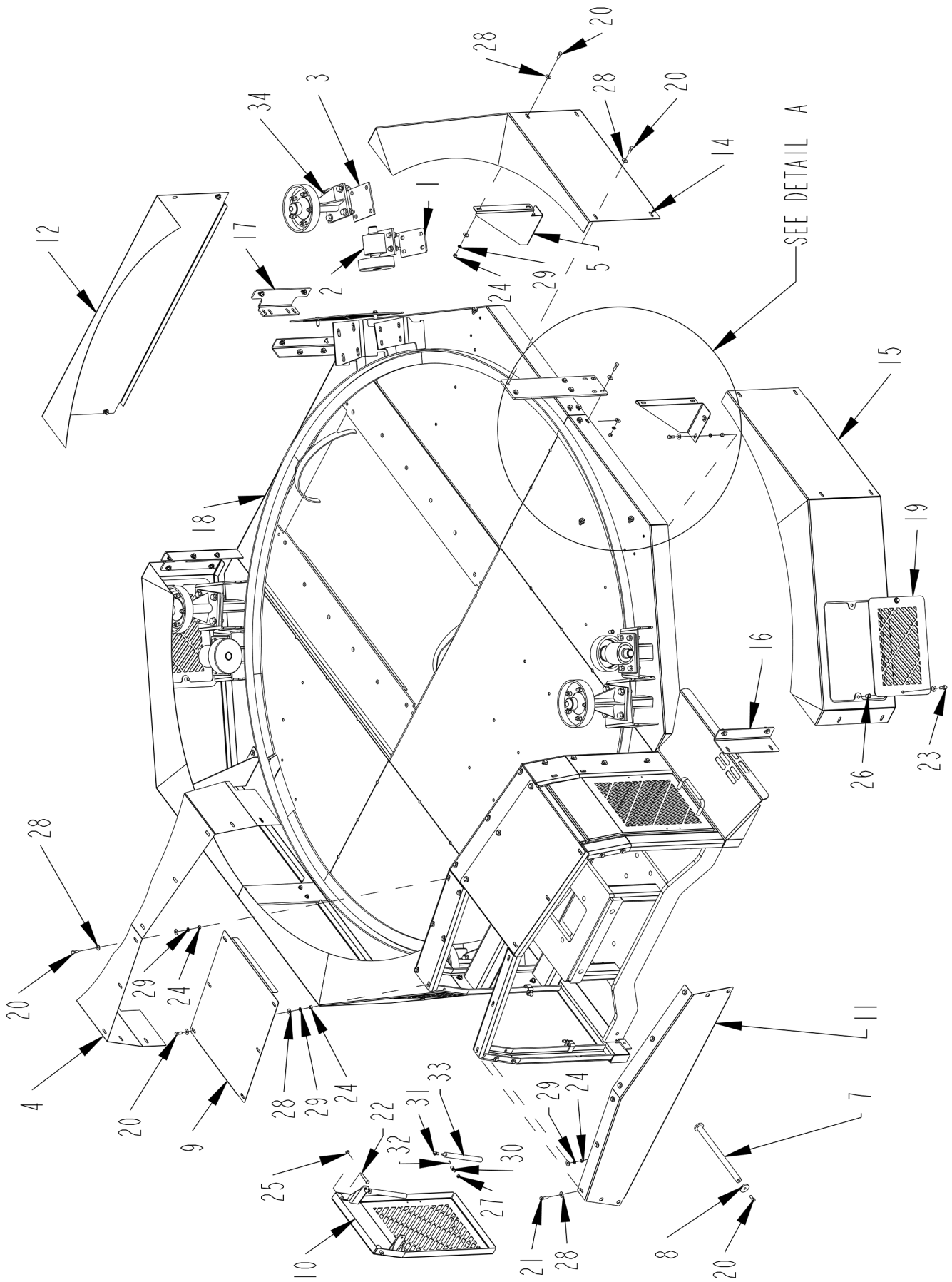


DETAIL A

**PLATFORM ASSEMBLY DETAIL A (S.N. 1110009630 TO 1115070030)**

<b>ITEM</b>	<b>PART</b>	<b>QTY.</b>	<b>PART DESCRIPTION</b>
1	4501131	4	SHIM\RLLR\SPPRT\TUB
2	4704069	4	RLLR\TUB\ASSY\STEEL\CAST
3	4501476	4	SHIM\RLLR\PRESS
4	4501518	1	SHLD\DRIVE\TUB
5	4501915	2	BRKT\SHLD\CHAIN\DRIVE\TUB
6	4501916	2	BRKT\SHLD\CHAIN\DRIVE\TUB
7	4501931	1	PIN\PLFRM\TILT\CYL
8	4501932	2	WASH\1-3/4 O.D.
9	4502088	2	CVR\DRV\TUB
10	4502089	2	DOOR\DRV\TUB
11	4502401	1	CVR\FR\FRMMN
12	4502422	1	SHLD\DRV\CHAIN\TUB\REAR
13	4502436	1	GRATE\MILLW\SLGBSTRS
14	4502631	2	SPPRT\SHLD\SD\TUB
15	4502663	2	SHLD\TUB\LR\F
16	4502662	2	SHLD\TUB\LF\RR
17	4502640	2	MNT\SHLD\TUB\FR
18	4502641	2	MNT\SHLD\TUB\REAR
19	4502642	1	FRM\PLFRM\TILT\1130\RTR\REAR
20	4703727	4	DOOR\SHLD\TUB
21	4800003	57	BOLT\HEX\3/8X1
22	4800098	14	BOLT\HEX\3/8X1-1/4\NC
23	4800146	4	BOLT\HEX\3/8X2
24	4800914	8	BOLT\FLG\SERR\3/8X1-1/4\NC
25	4900002	66	NUT\HEX\3/8\NC
26	4900023	4	NUT\TPLCK\3/8\NC
27	4900083	8	NUT\INSERT\3/8\LONG\0.15-0.312\(.418/CD)
28	4900142	8	NUT\TPLCK\5/16\NC
29	5000001	140	WASH\FLAT\3/8
30	5000019	66	WASH\LOCK\3/8
31	7500664	8	BALL STUD\SHOCK\FITTING\M6
32	7500665	8	END FITTING\GAS SPRING \m6
33	7500666	8	SAFETY CLIP
34	7500680	4	SPRNG\GAS\60LB\9416K174
35	4500247	4	RLLR\PRESS\COMPL
	<b>4502348</b>		<b>PLFRM\ASSY\SUB\H1130</b>
	<b>NOT SHOWN</b>		
	4500737	1	STOP\CYL\PLFRM
	4800046	1	PIN\CLEVIS\3/4X3
	4800107	1	PIN\HAIR\1/8(#9)
	4800468	4	SCR\RD\SLOT\#10-24X1/2\NC
	4900077	4	NUT\HEX\#10\NF
	5000071	4	WASH\LOCK\EXT\STAR\#10
	7500756	4	BMPR\RBBR\1-1/32X5/8

PLATFORM ASSEMBLY (S.N. 1116071930 AND UP)



**PLATFORM ASSEMBLY (S.N. 1116071930 AND UP)**

ITEM	PART	QTY.	PART DESCRIPTION
1	4501131	4	SHIM\RLLR\SPPRT\TUB
2	4704069	4	RLLR\TUB\ASSY\STEEL\CAST
3	4501476	4	SHIM\RLLR\PRESS
4	4501518	1	SHLD\DRIVE\TUB
5	4501915	2	BRKT\SHLD\CHAIN\DRIVE\TUB
6	4501916	2	BRKT\SHLD\CHAIN\DRIVE\TUB
7	4501931	1	PIN\PLFRM\TILT\CYL
8	4501932	2	WASH\1-3/4 O.D.
9	4502088	2	CVR\DRV\TUB
10	4502089	2	DOOR\DRV\TUB
11	4502401	1	CVR\FR\FRM\MN
12	4502422	1	SHLD\DRV\CHAIN\TUB\REAR
13	4502631	2	SPPRT\SHLD\SD\TUB
14	4502663	2	SHLD\TUB\LR\RF
15	4502662	2	SHLD\TUB\LF\RR
16	4502640	2	MNT\SHLD\TUB\FR
17	4502641	2	MNT\SHLD\TUB\REAR
18	4502642	1	FRM\PLFRM\TILT\1130\RTR\REAR
19	4703727	4	DOOR\SHLD\TUB
20	4800003	66	BOLT\HEX\3/8X1
21	4800098	14	BOLT\HEX\3/8X1-1/4\NC
22	4800146	4	BOLT\HEX\3/8X2
23	4800914	8	BOLT\FLG\SERR\3/8X1-1/4\NC
24	4900002	70	NUT\HEX\3/8\NC
25	4900023	4	NUT\TPLCK\3/8\NC
26	4900083	8	NUT\INSERT\3/8\LONG\0.15-0.312\(.418/CD)
27	4900142	8	NUT\TPLCK\5/16\NC
28	5000001	148	WASH\FLAT\3/8
29	5000019	70	WASH\LOCK\3/8
30	7500664	8	BALL STUD\SHOCK\FITTING\M6
31	7500665	8	END FITTING\GAS SPRING \m6
32	7500666	8	SAFETY CLIP
33	7500680	4	SPRNG\GAS\60LB\9416K174
34	4500247	4	RLLR\PRESS\COMPL

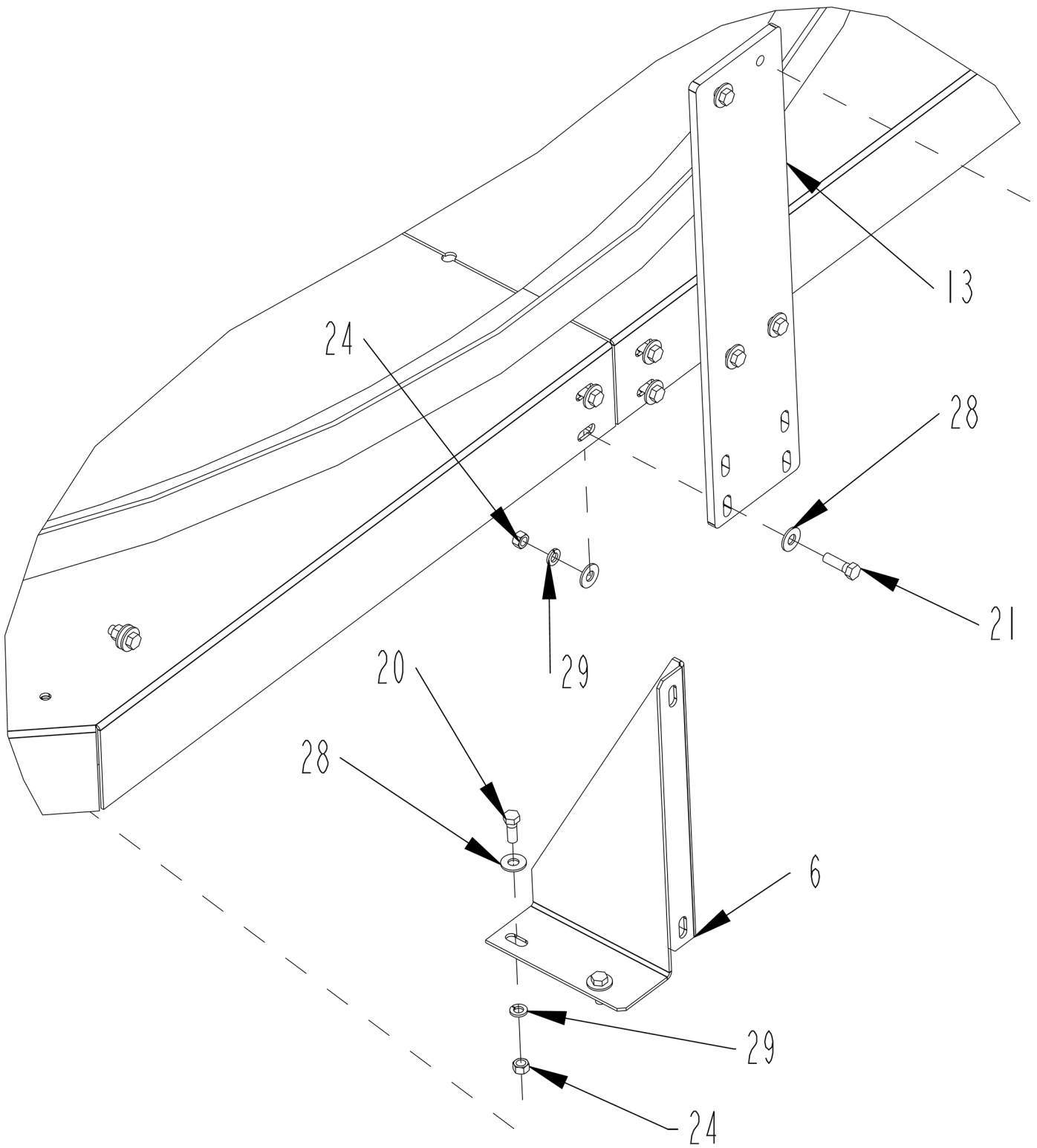
**4502348**

**PLTFRM\ASSY\SUB\H1130**

**NOT SHOWN**

4500737	1	STOP\CYL\PLFRM
4800046	1	PIN\CLEVIS\3/4X3
4800107	1	PIN\HAIR\1/8(#9)
4800468	4	SCR\RD\SLOT\#10-24X1/2\NC
4900077	4	NUT\HEX\#10\NF
5000071	4	WASH\LOCK\EXT\STAR\#10
7500756	4	BMPR\RBBR\1-1/32X5/8

PLATFORM ASSEMBLY DETAIL A (S.N. 1116071930 AND UP)



DETAIL A

**PLATFORM ASSEMBLY DETAIL A (S.N. 1116071930 AND UP)**

<b>ITEM</b>	<b>PART</b>	<b>QTY.</b>	<b>PART DESCRIPTION</b>
1	4501131	4	SHIM\RLLR\SPPRT\TUB
2	4704069	4	RLLR\TUB\ASSY\STEEL\CAST
3	4501476	4	SHIM\RLLR\PRESS
4	4501518	1	SHLD\DRIVE\TUB
5	4501915	2	BRKT\SHLD\CHAIN\DRIVE\TUB
6	4501916	2	BRKT\SHLD\CHAIN\DRIVE\TUB
7	4501931	1	PIN\PLFRM\TILT\CYL
8	4501932	2	WASH\1-3/4 O.D.
9	4502088	2	CVR\DRV\TUB
10	4502089	2	DOOR\DRV\TUB
11	4502401	1	CVR\FR\FRM\MN
12	4502422	1	SHLD\DRV\CHAIN\TUB\REAR
13	4502631	2	SPPRT\SHLD\SD\TUB
14	4502663	2	SHLD\TUB\LR\RF
15	4502662	2	SHLD\TUB\LF\RR
16	4502640	2	MNT\SHLD\TUB\FR
17	4502641	2	MNT\SHLD\TUB\REAR
18	4502642	1	FRM\PLFRM\TILT\1130\RTR\REAR
19	4703727	4	DOOR\SHLD\TUB
20	4800003	66	BOLT\HEX\3/8X1
21	4800098	14	BOLT\HEX\3/8X1-1/4\NC
22	4800146	4	BOLT\HEX\3/8X2
23	4800914	8	BOLT\FLG\SERR\3/8X1-1/4\NC
24	4900002	70	NUT\HEX\3/8\NC
25	4900023	4	NUT\TPLCK\3/8\NC
26	4900083	8	NUT\INSERT\3/8\LONG\0.15-0.312\(.418/CD)
27	4900142	8	NUT\TPLCK\5/16\NC
28	5000001	148	WASH\FLAT\3/8
29	5000019	70	WASH\LOCK\3/8
30	7500664	8	BALL STUD\SHOCK\FITTING\M6
31	7500665	8	END FITTING\GAS SPRING \m6
32	7500666	8	SAFETY CLIP
33	7500680	4	SPRNG\GAS\60LB\9416K174
34	4500247	4	RLLR\PRESS\COMPL

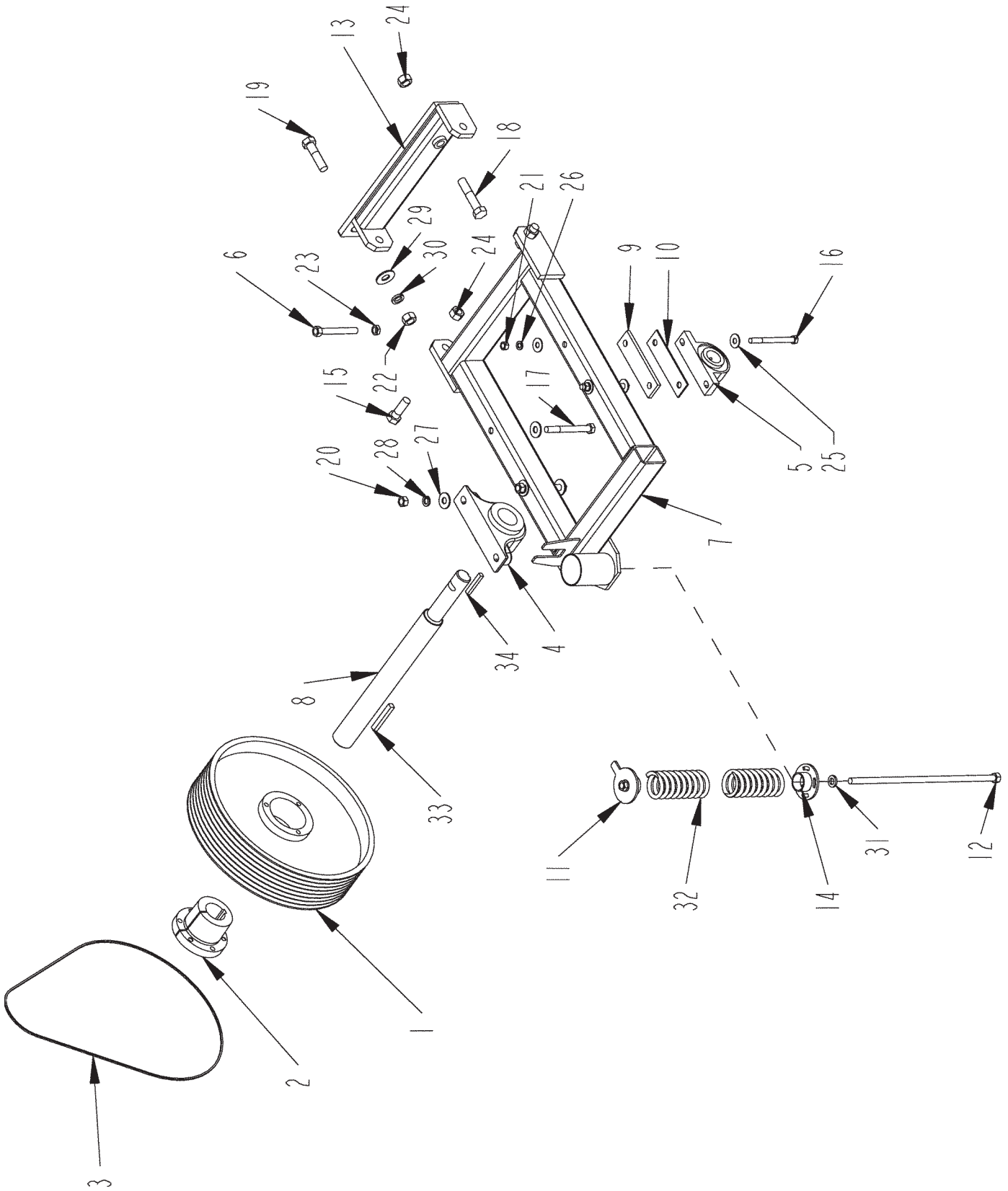
**4502348**

**PLTFRM\ASSY\SUB\H1130**

**NOT SHOWN**

4500737	1	STOP\CYL\PLFRM
4800046	1	PIN\CLEVIS\3/4X3
4800107	1	PIN\HAIR\1/8(#9)
4800468	4	SCR\RD\SLOT\#10-24X1/2\NC
4900077	4	NUT\HEX\#10\NF
5000071	4	WASH\LOCK\EXT\STAR\#10
7500756	4	BMPR\RBBR\1-1/32X5/8

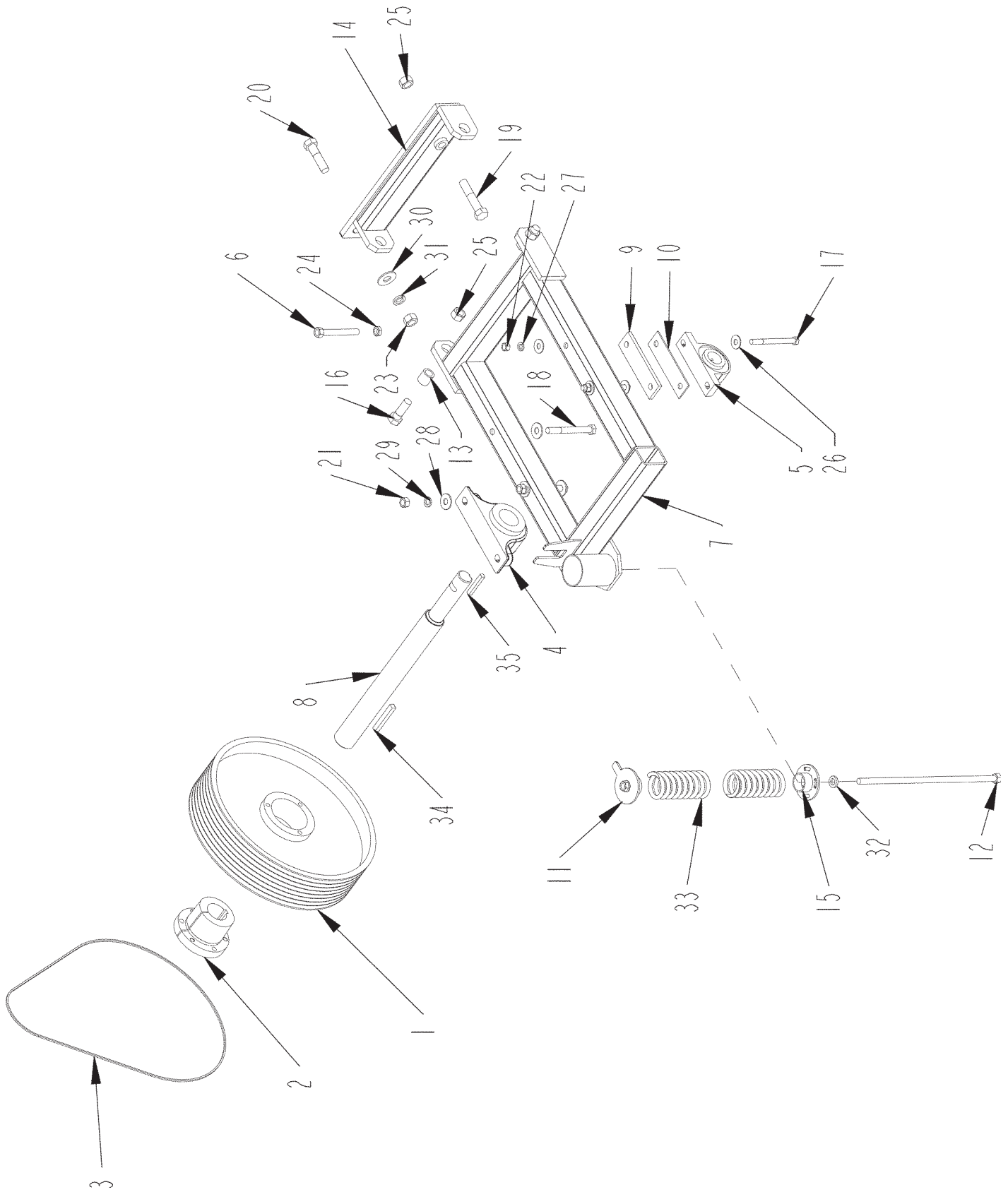
**BULL WHEEL ASSEMBLY (S.N. UP TO 1111025030)**



**BULL WHEEL ASSEMBLY (S.N. UP TO 1111025030)**

ITEM	PART	QTY.	PART DESCRIPTION
1	1400605	1	SHVE\5V-8\21.2\85V2120J
2	1400642	1	BUSH\QD\1\2-3/4
3	1600102	1	V-BELT\5VP850
4	2000509	1	BRG\PB\2-3/4\E\DODGE
5	2000510	1	BRG\PB\2\2BOLT
6	4501170	1	BOLT\FRM\TGHTNR\CHAIN\TUB
7	4502330	1	WHL\BULL\FRM\OFFSET
8	4502331	1	SHFT\WHL\BULL\OFFSET
9	4502333	1	SHIM\BRG\WHL\BULL
10	4502334	1	SHM\THN\BRG\WHL\BLL
11	4502338	1	CAP\SPRNG\TNSNR
12	4502340	1	ROD\TNSNR\WHL\BULL
13	4502419	1	ADJ\WHL\BLL
14	4502425	1	CAP\TNSNR\WHL\BLL
15	4800140	2	BOLT\HEX\1X3\NC
16	4800155	2	BOLT\HEX\5/8X7
17	4800295	2	BOLT\HEX\3/4X7
18	4800546	1	BOLT\HEX\1X5\NC
19	4800647	1	BOLT\HEX\1X4\NC
20	4900004	4	NUT\HEX\3/4\NC
21	4900005	2	NUT\HEX\5/8\NC
22	4900031	1	NUT\HEX\1\NC
23	4900104	1	NUT\JAM\3/4\NC
24	4900127	3	NUT\TPLCK\1\NC
25	5000002	4	WASH\FLAT\5/8
26	5000003	2	WASH\LOCK\5/8
27	5000005	4	WASH\FLAT\3/4
28	5000012	2	WASH\LOCK\3/4
29	5000014	1	WASH\FLAT\1
30	5000053	1	WASH\LOCK\1
31	5000115	1	WASH\FLAT\3/4\EXTRTHK\GR8
32	6100091	2	SPG\COMP\8X3-1/2OD\1/2WD
33	6200013	1	KEY\SQ\5/8X4-1/2
34	6200062	1	KEY\SQ\1/2X3-1/2

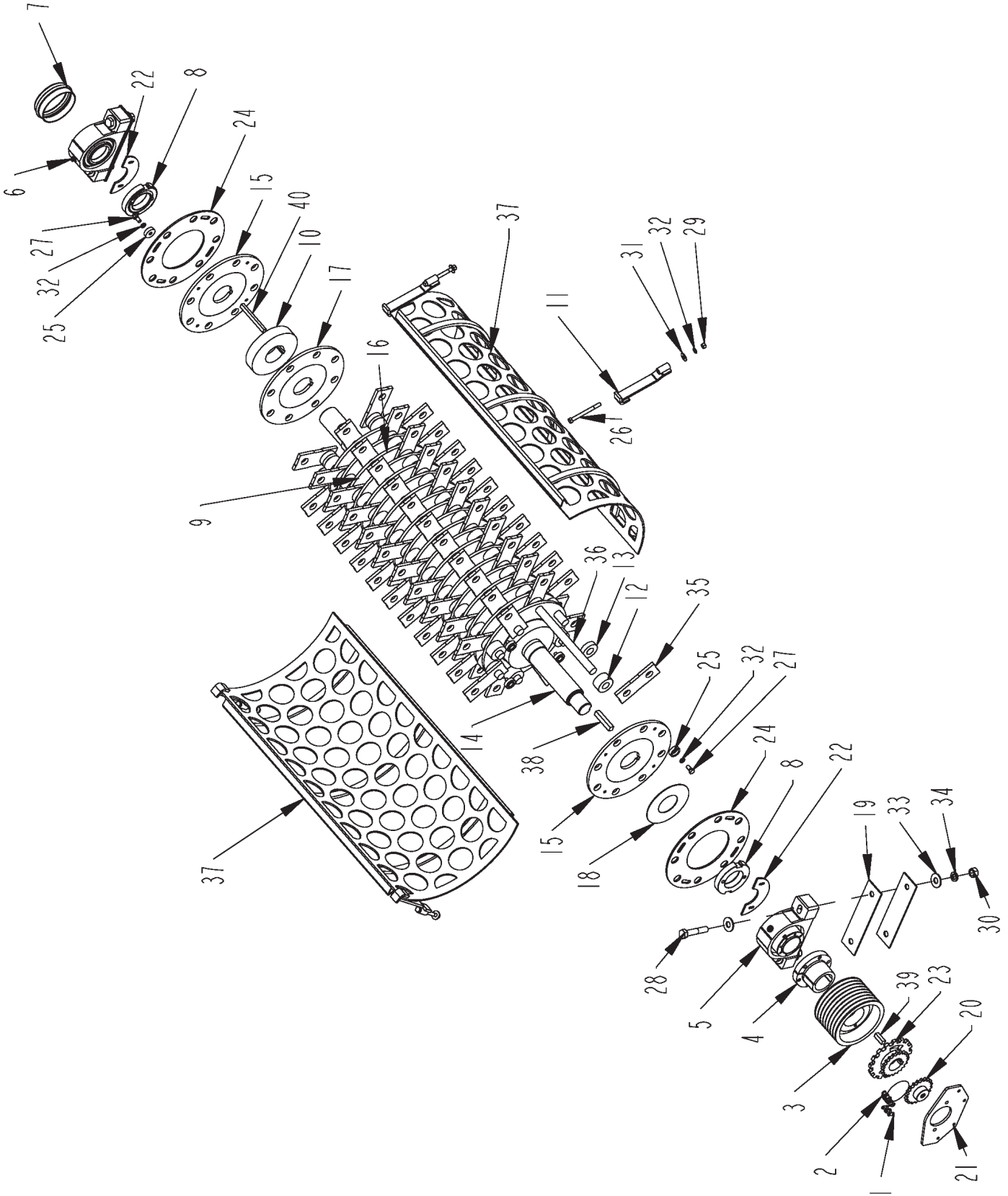
**BULL WHEEL ASSEMBLY (S.N. 1112025130 & UP )**



**BULL WHEEL ASSEMBLY ( S.N. 1112025130 & UP )**

<b>ITEM</b>	<b>PART</b>	<b>QTY.</b>	<b>PART DESCRIPTION</b>
1	1400605	1	SHVE\5V-8\21.2\85V2120J
2	1400642	1	BUSH\QDJ\2-3/4
3	1600102	1	V-BELT\5VP850
4	2000509	1	BRG\PB\2-3/4\E\DODGE
5	2000510	1	BRG\PB\2\2BOLT
6	4501170	1	BOLT\FRM\TGHTNR\CHAIN\TUB
7	4502330	1	WHL\BULL\FRM\OFFSET
8	4502331	1	SHFT\WHL\BULL\OFFSET
9	4502333	1	SHIM\BRG\WHL\BULL
10	4502334	1	SHM\THN\BRG\WHL\BLL
11	4502338	1	CAP\SPRNG\TNSNR
12	4502340	1	ROD\TNSNR\WHL\BULL
13	4502380	2	TUBE\WHL\BLL
14	4502419	1	ADJ\WHL\BLL
15	4502425	1	CAP\TNSNR\WHL\BLL
16	4800140	2	BOLT\HEX\1X3\NC
17	4800155	2	BOLT\HEX\5/8X7
18	4800295	2	BOLT\HEX\3/4X7
19	4800546	1	BOLT\HEX\1X5\NC
20	4800647	1	BOLT\HEX\1X4\NC
21	4900004	4	NUT\HEX\3/4\NC
22	4900005	2	NUT\HEX\5/8\NC
23	4900031	1	NUT\HEX\1\NC
24	4900104	1	NUT\JAM\3/4\NC
25	4900127	3	NUT\TPLCK\1\NC
26	5000002	4	WASH\FLAT\5/8
27	5000003	2	WASH\LOCK\5/8
28	5000005	4	WASH\FLAT\3/4
29	5000012	2	WASH\LOCK\3/4
30	5000014	1	WASH\FLAT\1
31	5000053	1	WASH\LOCK\1
32	5000115	1	WASH\FLAT\3/4\EXTRTHK\GR8
33	6100091	2	SPG\COMP\8X3-1/2OD\1/2WD
34	6200013	1	KEY\SQ\5/8X4-1/2
35	6200062	1	KEY\SQ\1/2X3-1/2
	<b>4502328</b>		<b>WHL\BULL\OFFSET\H1130</b>
	<b>NOT SHOWN</b>		
	3700961		HOSE\LUB\1/8X40\MPS-MPS
	3700963		HOSE\LUB\1/8X34\MPS-MPS

ROTOR ASSEMBLY (SN UP TO 111J005030)



**ROTOR ASSEMBLY (SN UP TO 111J005030)**

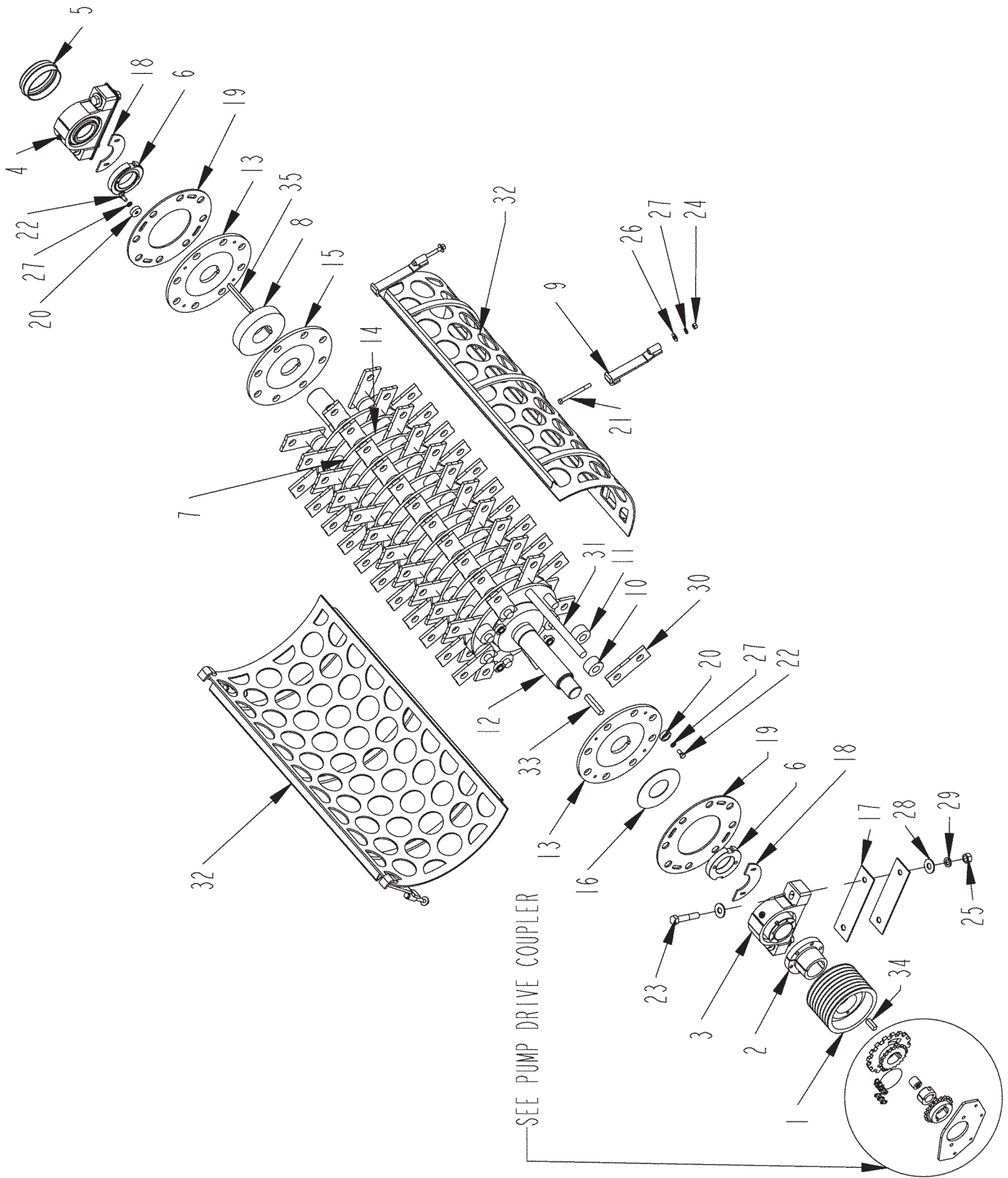
ITEM	PART	QTY.	PART DESCRIPTION
1	1100064	1	CHAIN\60DBL\CL
2	1100193	1	CHAIN\60DBL\19
3	1400637	1	SHVE\5V-8\9.25\F
4	1400641	1	BUSH\QD\F\3-1/4
5	2000585	1	BRG\PB\3-1/4\ISAF\NON-EXP
6	2000586	1	BRG\PB\3-1/4\ISAF\EXP
7	2900162	1	CAP\END\BRG\3-1/4\ISAF
8	4500142	2	NUT\CYL\3-1/2
9	4500348	16	SPCR\IRTR\1150\8X1.878
10	4500680	6	SPCR\ICAST\8.645\ODX3.503\IDX1.75 THICK
11	4501200	4	HOOK\SCRN\GRDR\BOLTED
12	4501266	88	SPCR\SHOCK\HMMR\IRTR\1150
13	4501267	88	SPCR\HMMR\IRTR\1150
14	4502315	1	SHFT\RTR\3-1/2X71-3/4\3-1/4BRG
15	4502318	2	PL\IRTR\1/2X3-1/2ID\1-1/4RDS\TPPD
16	4502319	16	PL\IRTR\1/2X3-1/2ID\GRV\1-1/4RDS
17	4502321	5	PL\IRTR\3.5X1/2X15.75\1-1/4RDS\FCD
18	4502322	1	WASH\THRUST\ROTOR\H1130
19	4502324	4	SHIM\BRG\IRTR\H1100SS
20	4502354	1	SPRKT\60\20\7/8\SPLINE\WELD
21	4502402	1	PL\MNT\PMP\TNDM
22	4502413	2	SEAL\SHAFT\3-1/4\IRTR
23	4502420	1	SPKT\DRV\PMP
24	4700519	2	PL\IRTR\MVBL\8.030\IDX1/4
25	4704292	8	WASHER\PL\MOVEABLE\IRTR
26	4800077	4	BOLT\HEX\1/2X5-1/2
27	4800085	8	BOLT\HEX\1/2X1
28	4800926	4	BOLT\HEX\7/8X4-1/2\NC
29	4900001	4	NUT\HEX\1/2\NC
30	4900022	4	NUT\HEX\7/8\NC
31	5000004	4	WASH\FLAT\1/2
32	5000006	12	WASH\LOCK\1/2
33	5000098	8	WASH\FLAT\7/8
34	5000106	4	WASH\LOCK\7/8
35	5200246	1	HMMR\SWING\1/2X3\2-HOLE\BLNCD>
36	5300105	8	ROD\HMMR\1-1/4X50
37	5400062	2	SCRN\4HL\1/4\H1100
38	6200024	1	KEY\SQ\3/4X4
39	6200029	1	KEY\SQ\5/8X2
40	6200035	4	KEY\RECT\1/2X5/8X6-1/4

**4502320 RTR\NEW\50X1.25RDI\H1130\3.5X72SHFT\3-1/4BRGS**  
**4502323 ROTOR\50X1-1/4RD\CMPLT\1130\3-1/4 BRGS, HMMRS**

**SCREENS**

5400095	SCREEN\1/8" HOLE\1/4\H1100
5400074	SCREEN\3/16" HOLE\1/4\H1100
5400052	SCREEN\1/4" HOLE\1/4\H1100
5400053	SCREEN\3/8" HOLE\1/4\H1100
5400054	SCREEN\1/2" HOLE\1/4\H1100
5400055	SCREEN\5/8" HOLE\1/4\H1100
5400056	SCREEN\3/4" HOLE\1/4\H1100
5400049	SCREEN\1" HOLE\1/4\H1100
5400066	SCREEN\1 1/2" HOLE\1/4\H1100
5400050	SCREEN\2" HOLE\1/4\H1100
5400051	SCREEN\3" HOLE\1/4\H1100
5400062	SCREEN\4" HOLE\1/4\H1100
5400102	SCREEN\5" HOLE\1/4\H1100
5400110	SCREEN\6" HOLE\1/4\H1100E
5400111	SCREEN\7" HOLE\1/4\H1100E
5400103	SCREEN\8" HOLE\1/4\H1100
5400080	SCREEN\DUMMY\1/4\H1100

ROTOR ASSEMBLY (S.N. 1110010130 TO 1111021930)



**ROTOR ASSEMBLY (S.N. 1110010130 TO 1111021930)**

ITEM	PART	QTY.	PART DESCRIPTION
1	1400637	1	SHVE\5V-8\9.25\F
2	1400641	1	BUSH\QDF\3-1/4
3	2000585	1	BRG\PB\3-1/4\ISAF\NON-EXP
4	2000586	1	BRG\PB\3-1/4\ISAF\EXP
5	2900162	1	CAP\END\BRG\3-1/4\ISAF
6	4500142	2	NUT\CYL\3-1/2
7	4500348	16	SPCR\RTR\1150\8X1.878
8	4500680	6	SPCR\CAST\8.645ODX3.503IDX1.75 THICK
9	4501200	4	HOOK\SCRN\GRDR\BOLTED
10	4501266	88	SPCR\SHOCK\HMMR\RTR\1150
11	4501267	88	SPCR\HMMR\RTR\1150
12	4502315	1	SHFT\RTR\3-1/2X71-3/4\3-1/4BRG
13	4502318	2	PL\RTR\1/2X3-1/2ID\1-1/4RDS\TPPD
14	4502319	16	PL\RTR\1/2X3-1/2ID\GRV\1-1/4RDS
15	4502321	5	PL\RTR\3.5X1/2X15.75\1-1/4RDS\FCD
16	4502322	1	WASH\THRUST\ROTOR\H1130
17	4502324	4	SHIM\BRG\RTR\H1100SS
18	4502413	2	SEAL\SHAFT\3-1/4\RTR
19	4700519	2	PL\RTR\MVBL\8.030IDX1/4
20	4704292	8	WASHER\PL\MOVEABLE\RTR
21	4800077	4	BOLT\HEX\1/2X5-1/2
22	4800085	8	BOLT\HEX\1/2X1
23	4800926	4	BOLT\HEX\7/8X4-1/2\NC
24	4900001	4	NUT\HEX\1/2\NC
25	4900022	4	NUT\HEX\7/8\NC
26	5000004	4	WASH\FLAT\1/2
27	5000006	12	WASH\LOCK\1/2
28	5000098	8	WASH\FLAT\7/8
29	5000106	4	WASH\LOCK\7/8
30	5200246	1	HMMR\SWING\1/2X3\2-HOLE\BLNCD>
31	5300105	8	ROD\HMMR\1-1/4X50
32	5400062	2	SCRN\4HL\1/4\H1100
33	6200024	1	KEY\SQ\3/4X4
34	6200029	1	KEY\SQ\5/8X2
35	6200035	4	KEY\RECT\1/2X5/8X6-1/4

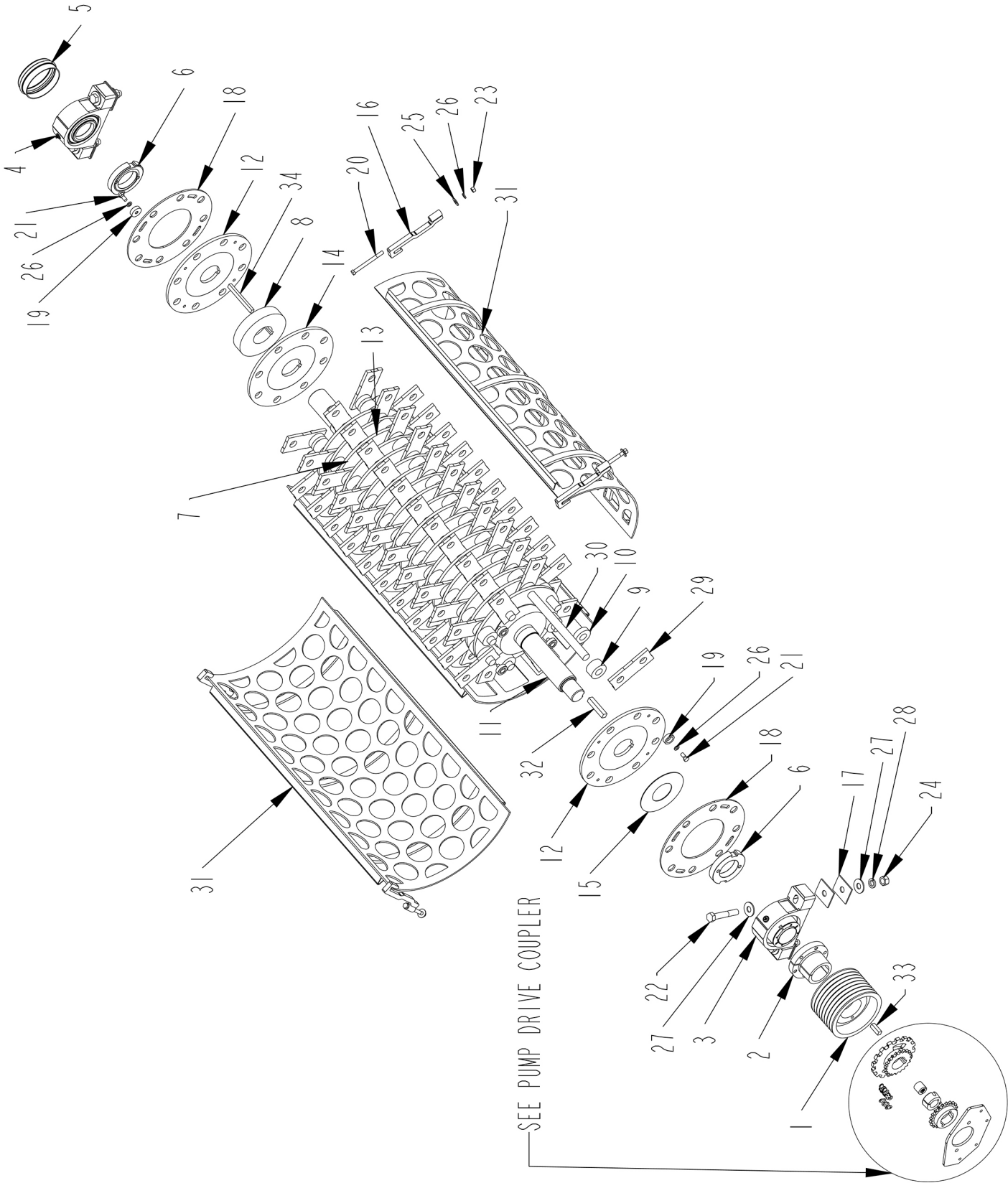
**4502320**  
**4502323**

**RTR\NEW\50X1.25RD\H1130\3.5X72SHFT\3-1/4BRGS**  
**ROTOR\50X1-1/4RD\CMPLT\1130\3-1/4 BRGS, HMMRS**

**SCREENS**

5400095	SCREEN\1/8" HOLE\1/4\H1100
5400074	SCREEN\3/16" HOLE\1/4\H1100
5400052	SCREEN\1/4" HOLE\1/4\H1100
5400053	SCREEN\3/8" HOLE\1/4\H1100
5400054	SCREEN\1/2" HOLE\1/4\H1100
5400055	SCREEN\5/8" HOLE\1/4\H1100
5400056	SCREEN\3/4" HOLE\1/4\H1100
5400049	SCREEN\1" HOLE\1/4\H1100
5400066	SCREEN\1 1/2" HOLE\1/4\H1100
5400050	SCREEN\2" HOLE\1/4\H1100
5400051	SCREEN\3" HOLE\1/4\H1100
5400062	SCREEN\4" HOLE\1/4\H1100
5400102	SCREEN\5" HOLE\1/4\H1100
5400110	SCREEN\6" HOLE\1/4\H1100E
5400111	SCREEN\7" HOLE\1/4\H1100E
5400103	SCREEN\8" HOLE\1/4\H1100
5400080	SCREEN\DUMMY\1/4\H1100

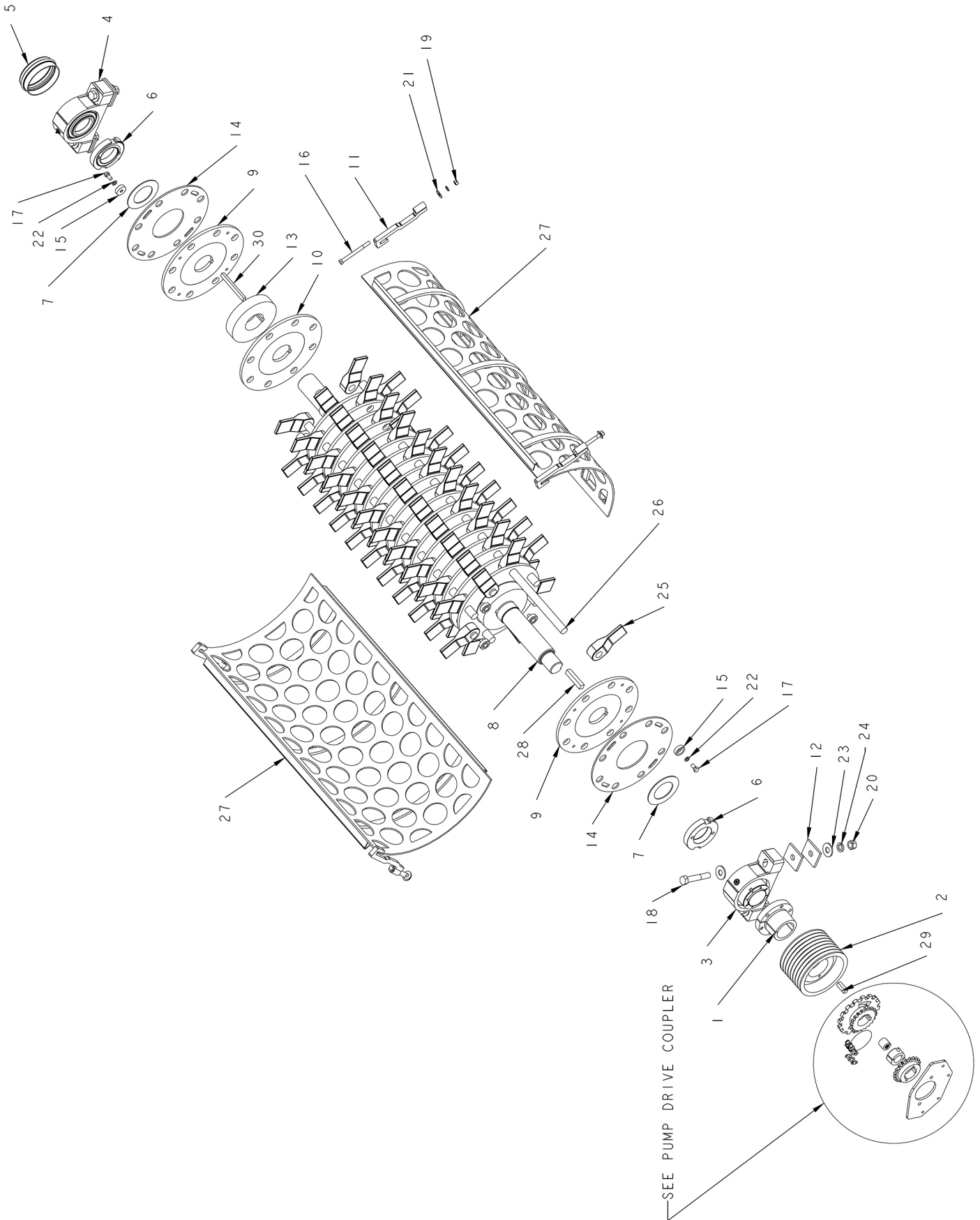
ROTOR ASSEMBLY (S.N. 1111022030 UP TO 1117090030)



**ROTOR ASSEMBLY (S.N. 1111022030 UP TO 1117090030)**

ITEM	PART	QTY.	PART DESCRIPTION
1	1400637	1	SHVE\5V-8\9.25\F (FOR SN UP TO 1111025030)
1A	1400667	1	SHVE\5V-8\9.75\F (FOR 11120288430 & UP)
2	1400641	1	BUSH\QD\F\3-1/4
3	2000585	1	BRG\PB\3-1/4\ISAF\NON-EXP
4	2000586	1	BRG\PB\3-1/4\ISAF\EXP
5	2900162	1	CAP\END\BRG\3-1/4\ISAF
6	4500142	2	NUT\CYL\3-1/2
7	4500348	16	SPCR\RTR\1150\8X1.878
8	4500680	6	SPCR\CAST\8.645ODX3.503IDX1.75 THICK
9	4501266	88	SPCR\SHOCK\HMMR\RTR\1150
10	4501267	88	SPCR\HMMR\RTR\1150
11	4502315	1	SHFT\RTR\3-1/2X71-3/4\3-1/4BRG
12	4502318	2	PL\RTR\1/2X3-1/2ID\1-1/4RDS\TPPD
13	4502319	16	PL\RTR\1/2X3-1/2ID\GRV\1-1/4RDS
14	4502321	5	PL\RTR\3.5X1/2X15.75\1-1/4RDS\FCD
15	4502322	1	WASH\THRUST\ROTOR\H1130
16	4502643	4	HOLDDOWN\SCRN\LASERED
17	4502670	8	SHIM\BRG\RTR
18	4700519	2	PL\RTR\MVBL\8.030IDX1/4
19	4704292	8	WASHER\PL\MOVEABLE\RTR
20	4800077	4	BOLT\HEX\1/2X5-1/2
21	4800085	8	BOLT\HEX\1/2X1
22	4800925	4	BOLT\HEX\7/8X5
23	4900001	4	NUT\HEX\1/2\NC
24	4900022	4	NUT\HEX\7/8\NC
25	5000004	4	WASH\FLAT\1/2
26	5000006	12	WASH\LOCK\1/2
27	5000098	8	WASH\FLAT\7/8
28	5000106	4	WASH\LOCK\7/8
29	5200246	1 SET	HMMR\SWING\1/2X3\2-HOLE\1-1/4RD\3'LONG\HF\SET88 <b>(1SET=88 HAMMERS)</b>
30	5300105	8	ROD\HMMR\1-1/4X50
31	5400062	2	SCRN\4HL\1/4\H1100
32	6200024	1	KEY\SQ\3/4X4
33	6200029	1	KEY\SQ\5/8X2
34	6200035	4	KEY\RECT\1/2X5/8X6-1/4
	<b>4502320</b>		<b>RTR\NEW\50X1.25RDIH1130\3.5X72SHFT\3-1/4BRGS</b>
	<b>4502323</b>		<b>ROTOR\50X1-1/4RD\CMPLT\1130\3-1/4 BRGS, HMMRS</b>
<b>SCREENS</b>			
	5400095		SCREEN\1/8" HOLE\1/4\H1100
	5400074		SCREEN\3/16" HOLE\1/4\H1100
	5400052		SCREEN\1/4" HOLE\1/4\H1100
	5400053		SCREEN\3/8" HOLE\1/4\H1100
	5400054		SCREEN\1/2" HOLE\1/4\H1100
	5400055		SCREEN\5/8" HOLE\1/4\H1100
	5400056		SCREEN\3/4" HOLE\1/4\H1100
	5400049		SCREEN\1" HOLE\1/4\H1100
	5400066		SCREEN\1 1/2" HOLE\1/4\H1100
	5400050		SCREEN\2" HOLE\1/4\H1100
	5400051		SCREEN\3" HOLE\1/4\H1100
	5400062		SCREEN\4" HOLE\1/4\H1100
	5400102		SCREEN\5" HOLE\1/4\H1100
	5400110		SCREEN\6" HOLE\1/4\H1100E
	5400111		SCREEN\7" HOLE\1/4\H1100E
	5400103		SCREEN\8" HOLE\1/4\H1100
	5400080		SCREEN\DUMMY\1/4\H1100

**ROTOR ASSEMBLY (S.N. 1118090130 AND UP)**



**ROTOR ASSEMBLY (S.N. 1118090130 AND UP)**

ITEM	PART	QTY.	PART DESCRIPTION
1	1400641	1	BUSH\QD\F3-1/4
2	1400667	1	SHVE\5V-8\9.75F
3	2000585	1	BRG\PB\3-1/4\ISAF\NON-EXP
4	2000586	1	BRG\PB\3-1/4\ISAF\EXP
5	2900162	1	CAP\END\BRG\3-1/4\ISAF
6	4500142	2	NUT\CYL\3-1/2
7	4500626	2	WASH\THRUST\3-5/8IDX6
8	4502315	1	SHFT\RTR\3-1/2X71-3/4\3-1/4BRG
9	4502318	2	PL\RTR\1/2X3-1/2ID\1-1/4RDS\TPPD
10	4502321	21	PL\RTR\3.5X1/2X15.75\1-1/4RDS\FCD
11	4502643	4	HOLDDOWN\SCRN\LASERED
12	4502670	8	SHIM\BRG\RTR
13	4502958	22	SPCR\CAST\8.645ODX3.503IDX1.773 THICK
14	4702292	2	PL\RTR\MVBL\6IDX15-3/4\1-1/4ROD
15	4704292	8	WASHER\PL\MOVEABLE\RTR
16	4800077	5	BOLT\HEX\1/2X5-1/2
17	4800085	8	BOLT\HEX\1/2X1
18	4800925	4	BOLT\HEX\7/8X5
19	4900001	5	NUT\HEX\1/2\NC
20	4900022	4	NUT\HEX\7/8\NC
21	5000004	5	WASH\FLAT\1/2
22	5000006	13	WASH\LOCK\1/2
23	5000098	8	WASH\FLAT\7/8
24	5000106	4	WASH\LOCK\7/8
25	5200262	1 set	HMMR\FORGED\1-1/4\SET\H1130\BAKKO\SET OF 88
26	5300105	8	ROD\HMMR\1-1/4X50
27	5400062	2	SCRN\4HL\1/4\H1100
28	6200024	1	KEY\SQ\3/4X4
29	6200029	1	KEY\SQ\5/8X2
30	6200035	4	KEY\RECT\1/2X5/8X6-1/4

**4502537**  
**4502538**

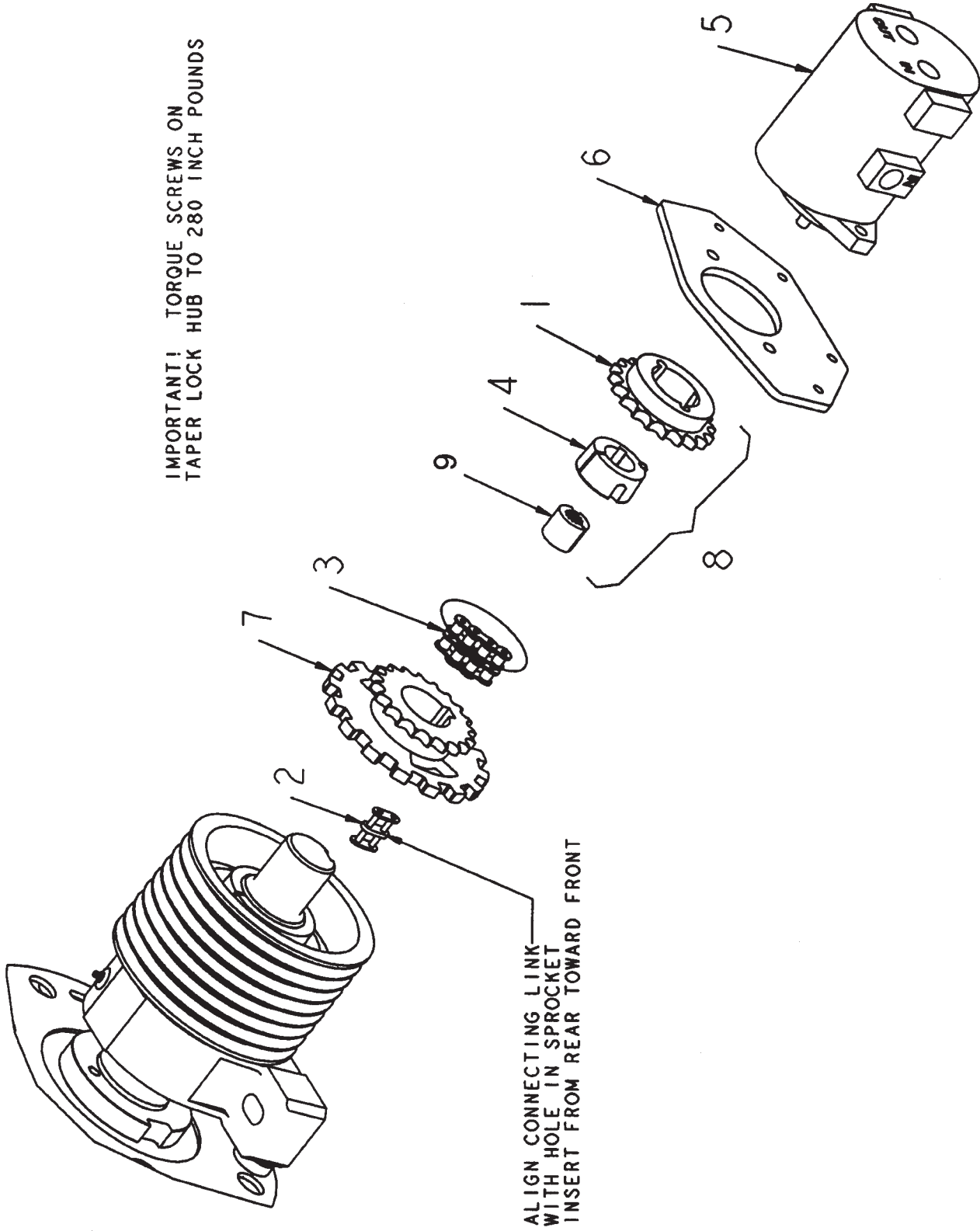
**RTR\ASSY\50X1-1/4ROD\1130\ALLCAST>**  
**RTR\BASE\50X1-1/4ROD\1130\ALLCAST>**

**SCREENS**

5400095	SCREEN\1/8" HOLE\1/4\H1100
5400074	SCREEN\3/16" HOLE\1/4\H1100
5400052	SCREEN\1/4" HOLE\1/4\H1100
5400053	SCREEN\3/8" HOLE\1/4\H1100
5400054	SCREEN\1/2" HOLE\1/4\H1100
5400055	SCREEN\5/8" HOLE\1/4\H1100
5400056	SCREEN\3/4" HOLE\1/4\H1100
5400049	SCREEN\1" HOLE\1/4\H1100
5400066	SCREEN\1 1/2" HOLE\1/4\H1100
5400050	SCREEN\2" HOLE\1/4\H1100
5400051	SCREEN\3" HOLE\1/4\H1100
5400062	SCREEN\4" HOLE\1/4\H1100
5400102	SCREEN\5" HOLE\1/4\H1100
5400110	SCREEN\6" HOLE\1/4\H1100E
5400111	SCREEN\7" HOLE\1/4\H1100E
5400103	SCREEN\8" HOLE\1/4\H1100
5400080	SCREEN\DUMMY\1/4\H1100

# PUMP DRIVE COUPLER

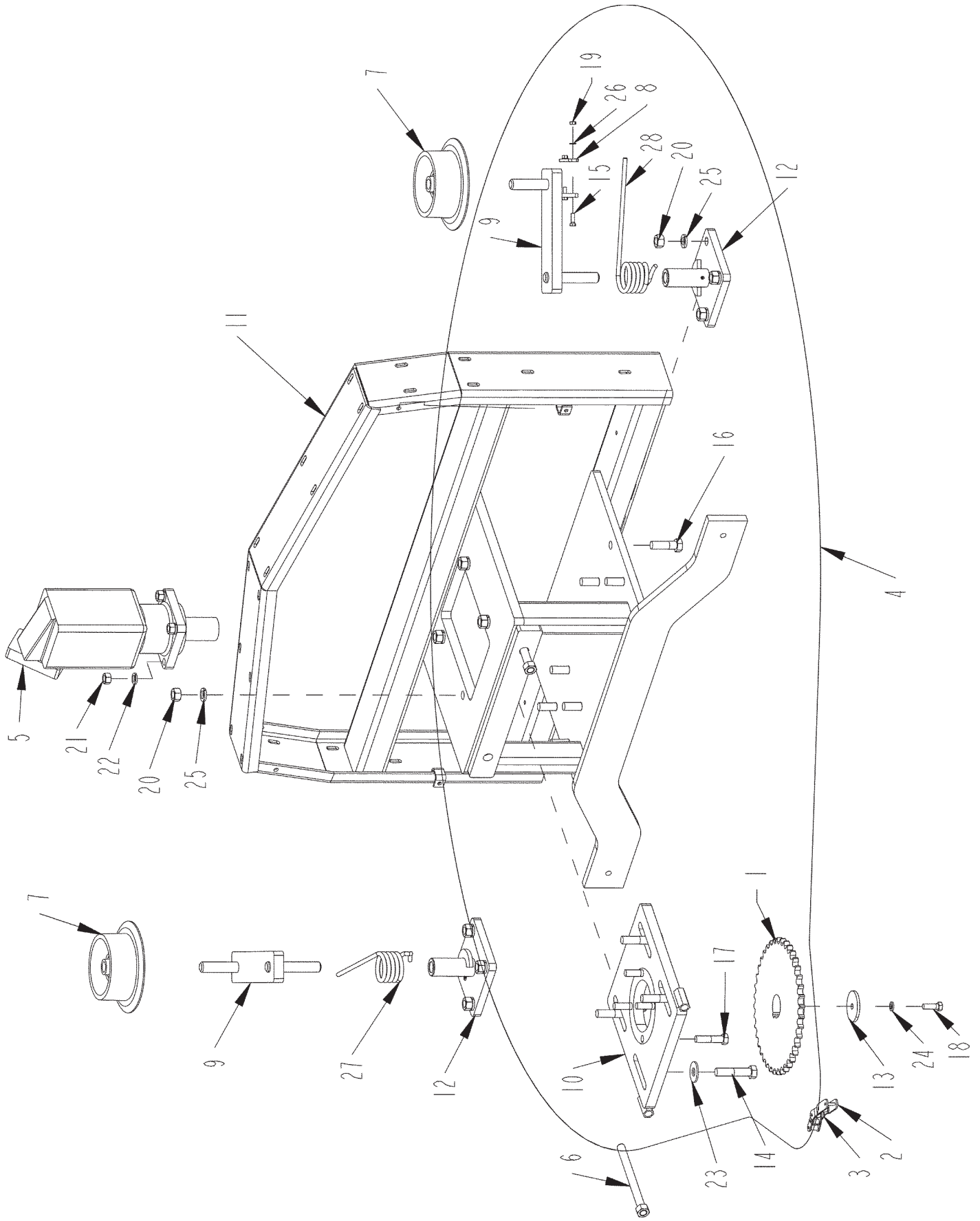
IMPORTANT! TORQUE SCREWS ON  
TAPER LOCK HUB TO 280 INCH POUNDS



## PUMP DRIVE COUPLER

ITEM	PART	QTY.	PART DESCRIPTION
1	1000295	1	SPKT\60\TPR\20\2012\REV
2	1100064	1	CHAIN\60DBL\CL
3	1100193	1	CHAIN\60DBL\19
4	1400658	1	BUSH\TAPER\1-1/2\2012\W\KEY
5	4200142	1	PUMP\HYD\TNDM\1.78CIDX1.3CID
6	4502402	1	PL\MNT\PMP\TNDM
7	4502420	1	SPKT\DRV\PMP
8	4502627	1	CPLR\PUMP\6020CHNX7/8SPLN
9	7501443	1	INSERT\SPLINED\7/8;13TTHX1-1/2OD

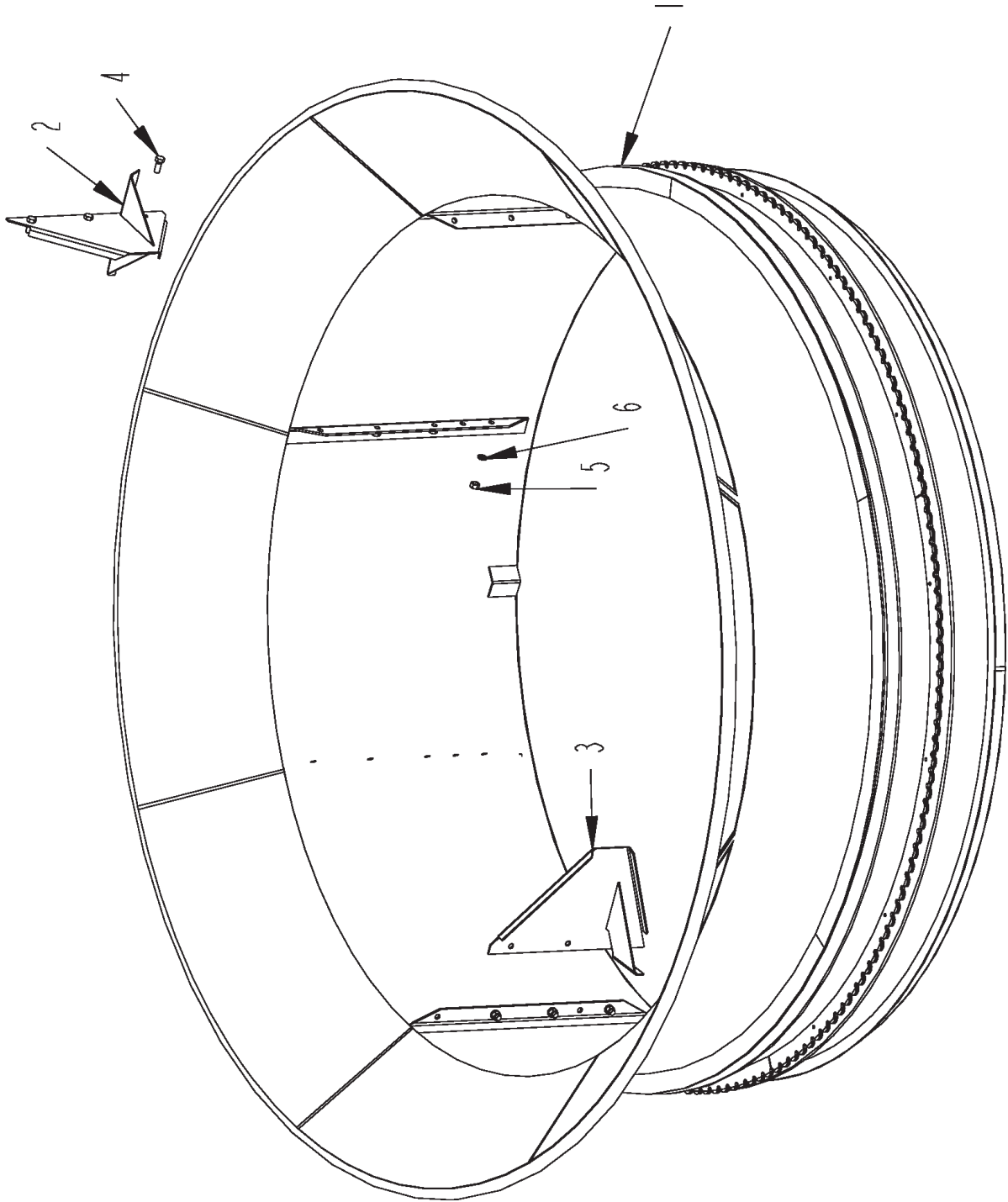
# TUB DRIVE ASSEMBLY



**TUB DRIVE ASSEMBLY**

<b>ITEM</b>	<b>PART</b>	<b>QTY.</b>	<b>PART DESCRIPTION</b>
1	1000237	1	SPKT\80\B\40\2-1/4\1/2KW
2	1100070	1	CHAIN\2080\CL
3	1100071	1	CHAIN\2080\OL
4	1100260	1	CHAIN\2080\183
5	4200121	1	MTR\HYD\40.6\1000\2-1/4\1-5/16FOR
6	4501328	2	BOLT\HEX\3X4X8-1/2
7	4501331	2	RLLR\DR\TUB
8	4501383	2	BRKT\SPRING\
9	4501705	2	BRKT\RLLR\TNSN
10	4501707	1	BRKT\MTR\DRV\TUB
11	4502642	1	FRM\PLFRM\TILT\1130\RTR\REAR
12	4703168	2	BRKT\RLLR\TNSN
13	4703713	1	WASH\MTR\ORBIT
14	4800011	4	BOLT\HEX\3/4X3-1/2
15	4800013	4	BOLT\HEX\5/16X1
16	4800115	8	BOLT\HEX\3/4X2-1/2
17	4800196	4	BOLT\HEX\5/8X2-3/4
18	4800575	1	BOLT\HEX\1/2X1-1/2\NF
19	4900003	4	NUT\HEX\5/16\NC
20	4900004	14	NUT\HEX\3/4\NC
21	4900005	4	NUT\HEX\5/8\NC
22	5000003	4	WASH\LOCK\5/8
23	5000005	4	WASH\FLAT\3/4
24	5000006	1	WASH\LOCK\1/2
25	5000012	12	WASH\LOCK\3/4
26	5000022	4	WASH\LOCK\5/16
27	6100078	1	SPG\DR\TUB
28	6100079	1	SPG\DR\TUB

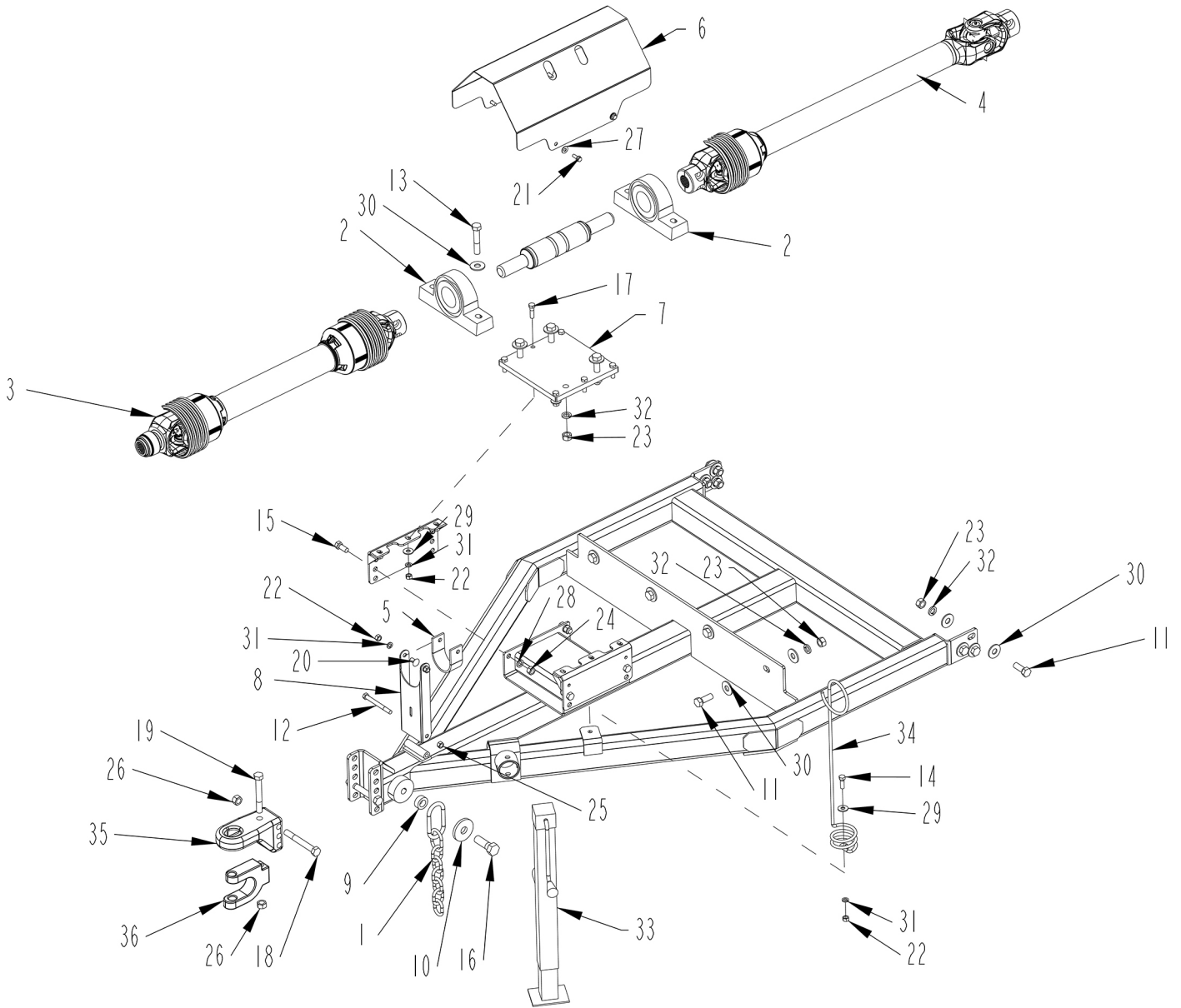
# TUB ASSEMBLY



## TUB ASSEMBLY

ITEM	PART	QTY.	PART DESCRIPTION
1	4502346	1	TUB\H1100\TTH\CNTNS
2	4502409	1	AGTTR\TUB\FIN\10
3	4502410	1	AGTTR\TUB\FIN\14
4	4800106	6	BOLT\HEX\5/8X1-1/2
5	4900005	6	NUT\HEX\5/8\NC
6	5000003	6	WASH\LOCK\5/8

# HITCH / DRIVE LINE ASSEMBLY



**HITCH / DRIVE LINE ASSEMBLY**

<b>ITEM</b>	<b>PART</b>	<b>QTY.</b>	<b>PART DESCRIPTION</b>
1	1100285	1	CHAIN\3/8\SFTY\AG\2100LB
2	2000512	2	BRG\PB\3\2BOLT\E\DODGE
3	3600698	1	PTO\COMP\77E\20SP\1-3/4
3A	3600699	1	PTO\COMP\77E\21SP\1-3/8
4	3600700	1	PTO\SCNDRY\77E
5	4500754	1	BELT\BRKT\PTO
6	4502448	1	SHLD\SHFT\JACK
7	4502450	1	PL\MNT\BRG\SHFT\JCK
8	4502672	1	BRKT\PTO
9	4704337	1	BUSHING\MNT\CHAIN\SAFETY
10	4704338	1	WASHER\CHAIN\SAFETY
11	4800033	10	BOLT\HEX\3/4X2
12	4800041	1	BOLT\HEX\1/2X5
13	4800063	4	BOLT\HEX\3/4X4
14	4800082	1	BOLT\HEX\1/2X1-1/2
15	4800106	4	BOLT\HEX\5/8X1-1/2
16	4800140	1	BOLT\HEX\1X3\NC
17	4800178	6	BOLT\HEX\1/2X1-3/4
18	4800248	2	BOLT\HEX\3/4X6
19	4800492	1	BOLT\HEX\3/4X5-1/2\GR8\NC
20	4800908	2	BOLT\CRG\1/2X1
21	4800913	4	BOLT\FLG\SERR\3/8X1\NC
22	4900001	9	NUT\HEX\1/2\NC
23	4900004	14	NUT\HEX\3/4\NC
24	4900005	4	NUT\HEX\5/8\NC
25	4900014	1	NUT\TPLCK\1/2\NC
26	4900139	3	NUT\TPLCK\3/4\GR8\NC
27	5000001	4	WASH\FLAT\3/8
28	5000003	4	WASH\LOCK\5/8
29	5000004	7	WASH\FLAT\1/2
30	5000005	24	WASH\FLAT\3/4
31	5000006	9	WASH\LOCK\1/2
32	5000012	14	WASH\LOCK\3/4
33	5800633	1	JACK\7000\SDWND\SQ\15"TRVL
34	7500170	1	HOSE MINDER
35	7501047	1	HITCH\BASE\#3\PP\1"PIN
36	7501048	1	HITCH\CLEVIS\PP\1"PIN

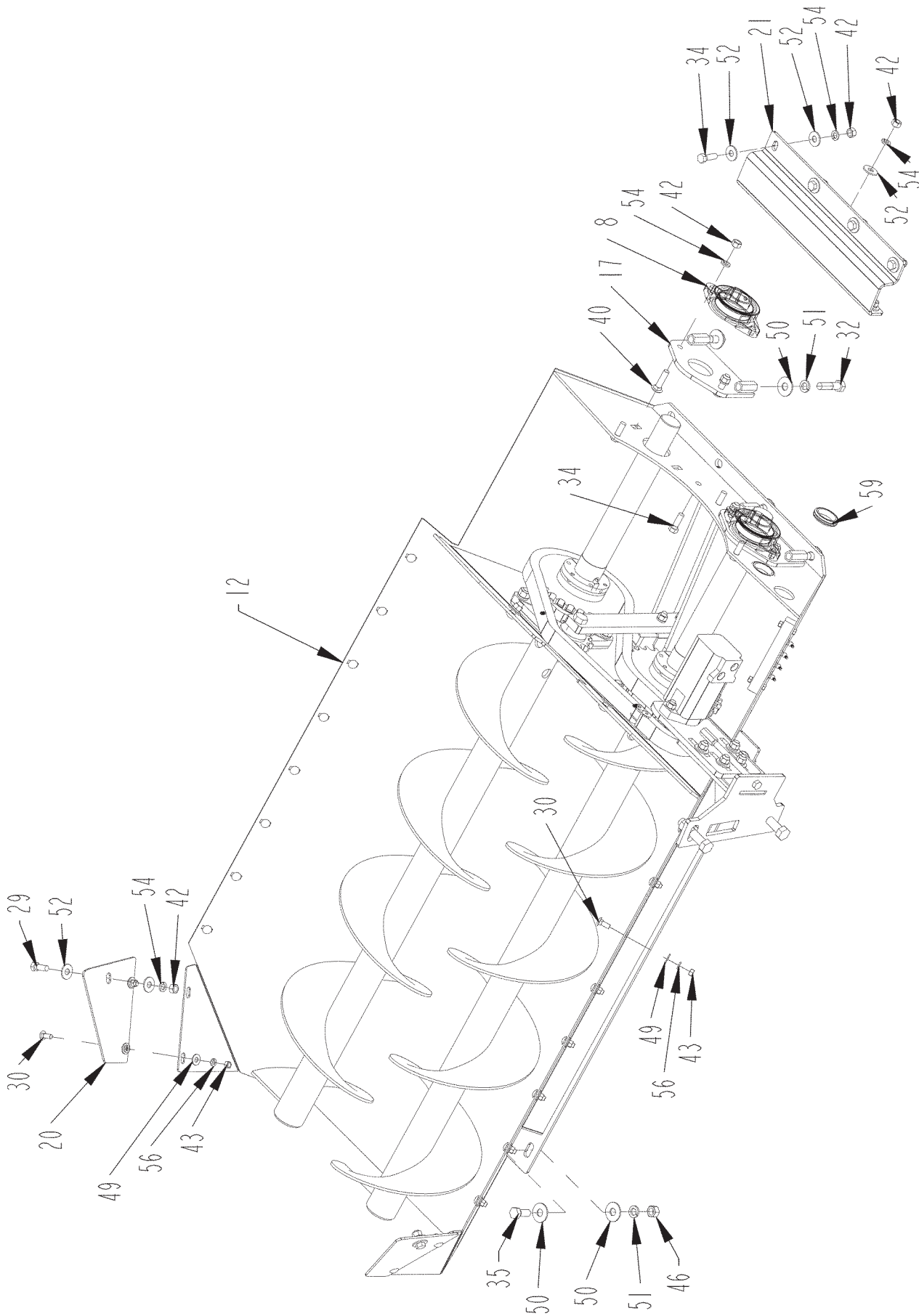
**4502411**

**HITCH\ASSY\CMLT\H1130**

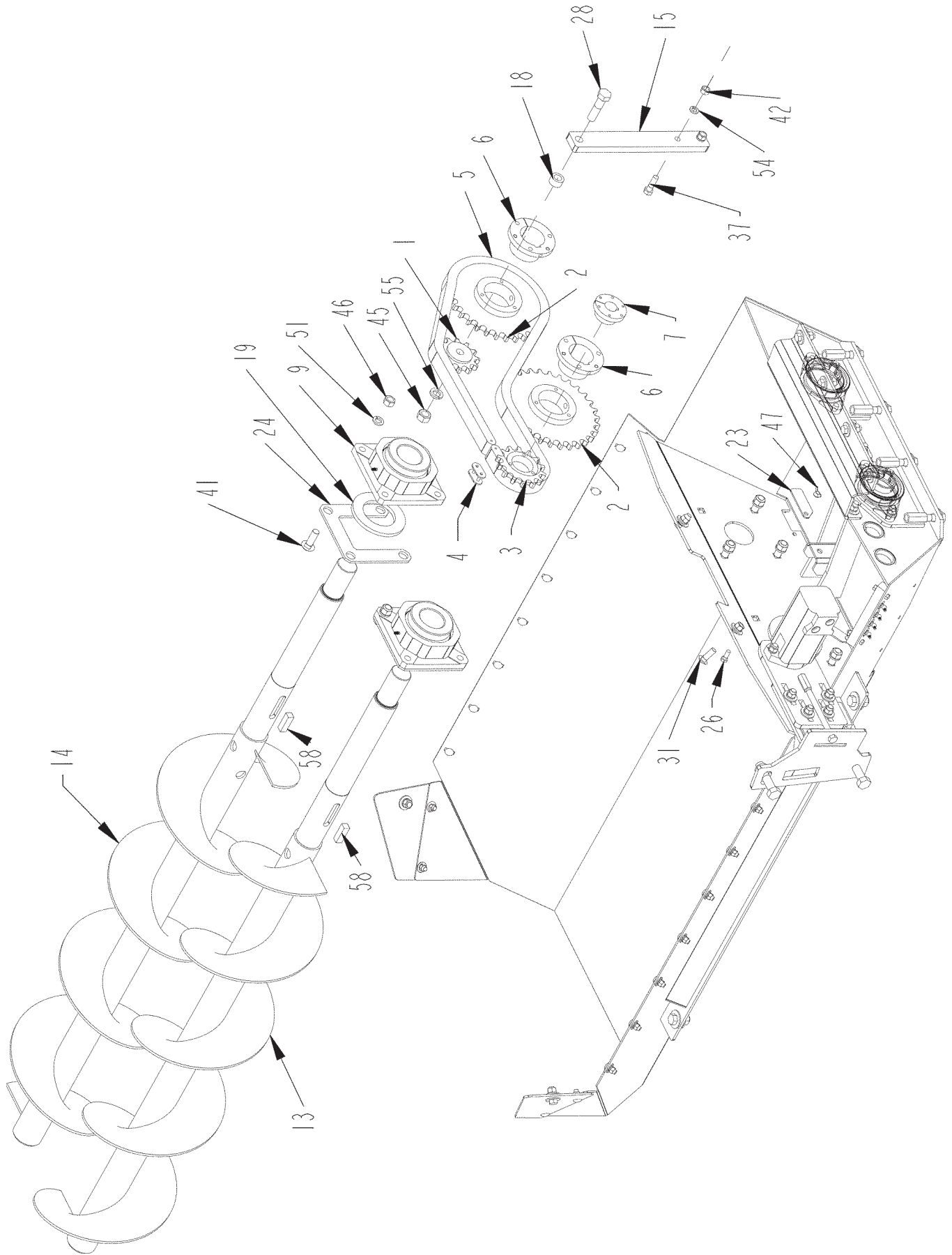
**NOT SHOWN (FOR PTO)**

4800021	2	BOLT\HEX\5/8X3
4900005	2	NUT\HEX\5/8\NC

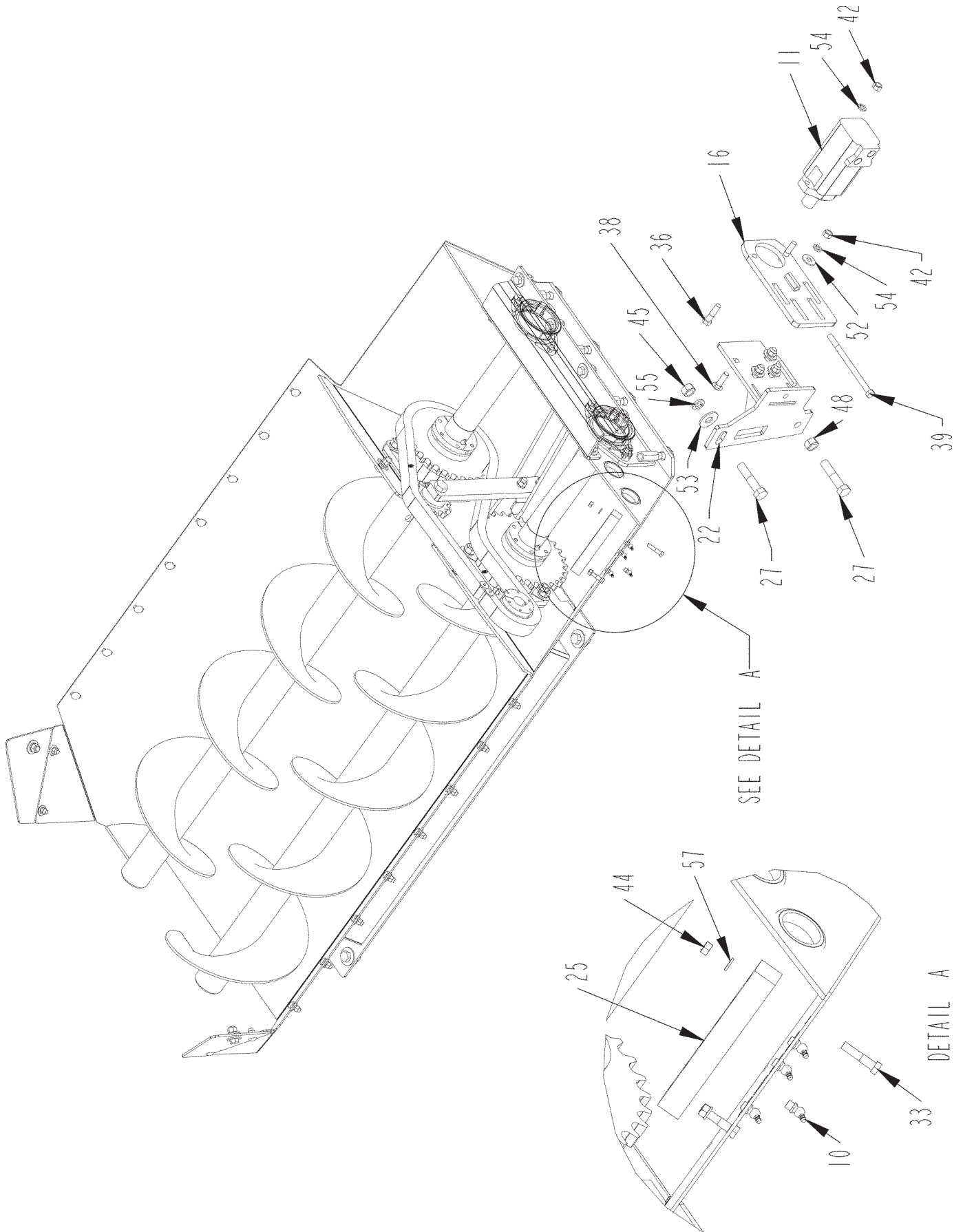
**BELLY CONVEYOR AUGER ASSEMBLY #1 (UP TO S.N. 1113040030)**



**BELLY CONVEYOR AUGER ASSEMBLY #2 (UP TO S.N. 1113040030)**



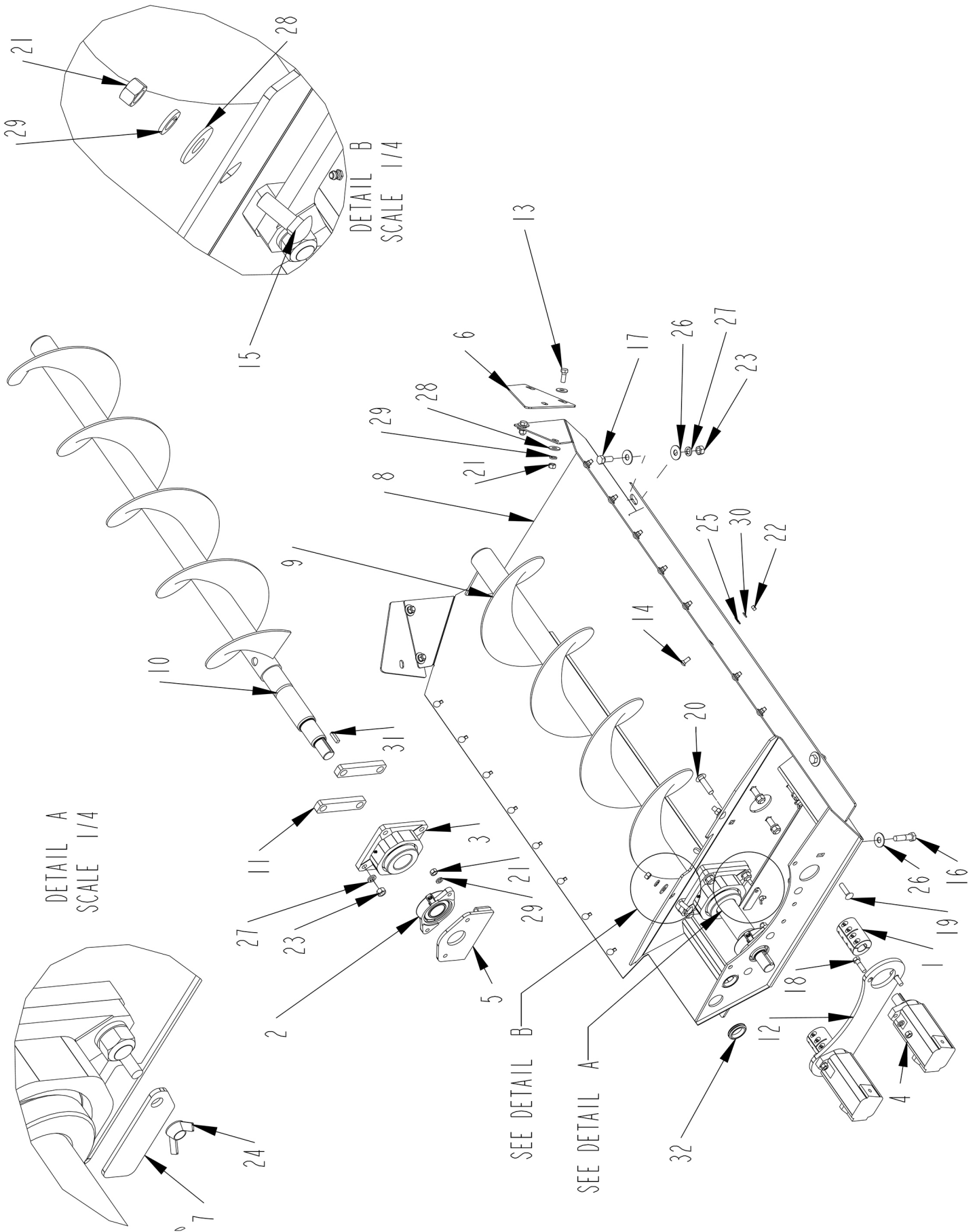
**BELLY CONVEYOR AUGER ASSEMBLY DETAIL A (UP TO S.N. 1113040030)**



**BELLY CONVEYOR AUGER ASSEMBLY (UP TO S.N. 1113040030)**

<b>ITEM</b>	<b>PART</b>	<b>QTY.</b>	<b>PART DESCRIPTION</b>
1	1000194	1	SPKT\80\12\3/4\IDLER
2	1000286	2	SPKT\80\QD\30\SF
3	1000292	1	SPKT\80\QD\14SDS
4	1100189	1	CHAIN\80\CL
5	1100309	1	CHAIN\80\69
6	1400645	2	BUSH\QD\2-1/2
7	1400648	1	BUSH\QD\SDS\1-1/4\5/16KEY
8	2000587	2	BRG\FLG\2"-BLT\SSCRW
9	2000588	2	BRG\FLG\2-1/2\4-BLT\D-LOCK
10	3800135	4	FTG\LUB\1/8MPXZRK\SHORT
11	3900020	1	MTR\HYD\11.9\2000\SAE;A;
12	4502301	1	PAN\CNVYR\BELLY\H1130
13	4502306	1	AUGER\RIGHT
14	4502307	1	AUGER\LEFT
15	4502309	1	ARM\IDLR\CHN
16	4502310	1	TNSNR\DR\CNVYR\BLLY
17	4502312	2	ADJSTR\BRG\FR
18	4502313	1	TUBE\SPCR\IDLR
19	4502376	2	CNVR BRNG SEAL
20	4502427	2	SH\SIDE\PAN\CNVYR
21	4502437	1	BRCKT\MNT\CNVYR\FR
22	4502438	1	BRCKT\MNT\DRV\AGRS\BLLY
23	4502603	2	CVR\HOLE\DRN
24	4502604	2	SPCR\BRG\AGR\CNVYR
25	4502605	1	MNFLD\GREASE\CONV\BLLY
26	4800003	2	BOLT\HEX\3/8X1
27	4800011	2	BOLT\HEX\3/4X3-1/2
28	4800017	1	BOLT\HEX\3/4X3
29	4800018	2	BOLT\HEX\1/2X1-1/4
30	4800053	20	BOLT\CRG\3/8X1\NC
31	4800061	2	BOLT\CRG\1/2X1-1/2\NC
32	4800079	4	BOLT\HEX\5/8X2-1/2
33	4800081	2	BOLT\HEX\5/16X1-1/2
34	4800082	8	BOLT\HEX\1/2X1-1/2
35	4800106	4	BOLT\HEX\5/8X1-1/2
36	4800114	2	BOLT\HEX\1/2X2
37	4800178	2	BOLT\HEX\1/2X1-3/4
38	4800201	4	BOLT\CRG\1/2X1-3/4\NC\GR5
39	4800262	1	BOLT\HEX\1/2X7-1/2
40	4800334	4	BOLT\CRG\1/2X2\NC
41	4800483	8	BOLT\CRG\5/8X2\NC
42	4900001	24	NUT\HEX\1/2\NC
43	4900002	20	NUT\HEX\3/8\NC
44	4900003	2	NUT\HEX\5/16\NC
45	4900004	2	NUT\HEX\3/4\NC
46	4900005	12	NUT\HEX\5/8\NC
47	4900032	2	NUT\WING\3/8\NC
48	4900139	1	NUT\TPLCK\3/4\GR8\NC
49	5000001	13	WASH\FLAT\3/8
50	5000002	12	WASH\FLAT\5/8
51	5000003	16	WASH\LOCK\5/8
52	5000004	30	WASH\FLAT\1/2
53	5000005	1	WASH\FLAT\3/4
54	5000006	32	WASH\LOCK\1/2
55	5000012	2	WASH\LOCK\3/4
56	5000019	13	WASH\LOCK\3/8
57	5000022	2	WASH\LOCK\5/16
58	6200092	2	KEY\RECT\1/2X5/8X2-1/4
59	7500360	2	GRMT\RBBR\2X1.75\DX1/4T
	<b>NOT SHOWN</b>		
	3700769	2	HOSE\LUB\1/8X23\MP5-MPS
	3700963	2	HOSE\LUB\1/8X34\MP5-MPS

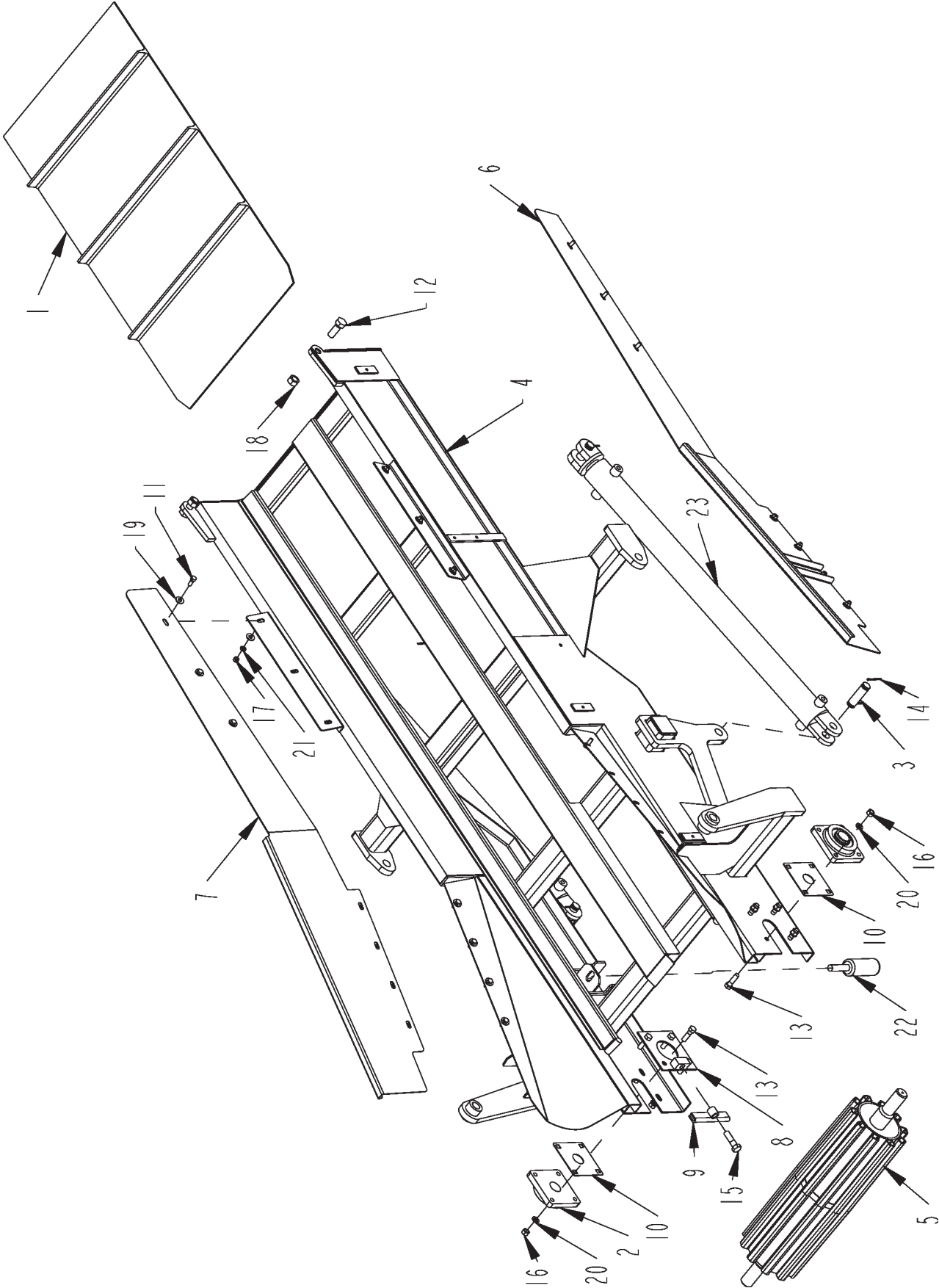
**BELLY AUGER ASSEMBLY (S.N. 1113040130 AND UP)**



**BELLY AUGER ASSEMBLY (S.N. 1113040130 AND UP)**

<b>ITEM</b>	<b>PART</b>	<b>QTY.</b>	<b>PART DESCRIPTION</b>
1	1400659	2	CPLR\RIGID\1.5X1.25
2	2000587	2	BRG\FLG\2"-BLT\SSCRW
3	2000588	2	BRG\FLG\2-1/2\4-BLT\D-LOCK
4	3900005	2	MTR\HYD\14.9\2000\SAE;A
5	4502312	2	ADJSTR\BRG\FR
6	4502427	2	SH\SIDE\PAN\CNVYR
7	4502603	2	CVR\HOLE\DRN
8	4502657	1	WELD\PAN\CNVYR\BELLY\H1130
9	4502658	1	AUGER\RIGHT
10	4502659	1	AUGER\LEFT
11	4502666	4	SPCR\BRG\AGR\CNVYR
12	4502755	1	BRKT\MTR\DRIVE
13	4800018	4	BOLT\HEX\1/2X1-1/4
14	4800053	16	BOLT\CRG\3/8X1\NC
15	4800061	2	BOLT\CRG\1/2X1-1/2\NC
16	4800079	4	BOLT\HEX\5/8X2-1/2
17	4800106	4	BOLT\HEX\5/8X1-1/2
18	4800178	4	BOLT\HEX\1/2X1-3/4
19	4800334	4	BOLT\CRG\1/2X2\NC
20	4801232	8	BOLT\CRG\5/8X2-1/2
21	4900001	14	NUT\HEX\1/2\NC
22	4900002	16	NUT\HEX\3/8\NC
23	4900005	12	NUT\HEX\5/8\NC
24	4900032	2	NUT\WING\3/8\NC
25	5000001	16	WASH\FLAT\3/8
26	5000002	12	WASH\FLAT\5/8
27	5000003	16	WASH\LOCK\5/8
28	5000004	10	WASH\FLAT\1/2
29	5000006	14	WASH\LOCK\1/2
30	5000019	16	WASH\LOCK\3/8
31	6200021	2	KEY\SQ\3/8X1-1/2\HARDEND
32	7500360	2	GRMT\RBBR\2X1.75IDX1/4T
	<b>4502660</b>		<b>CNVYR\BLLY\H1130</b>

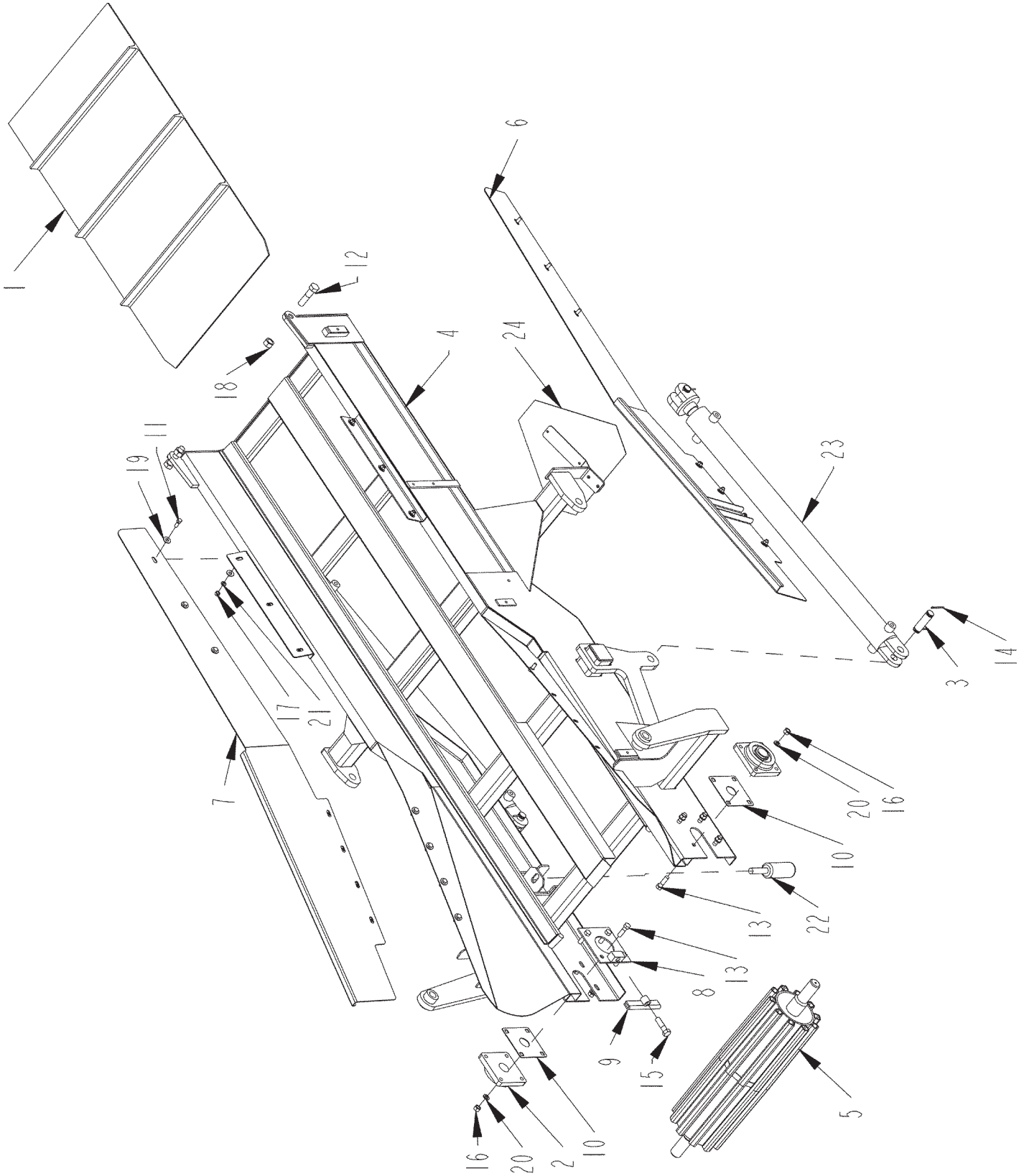
LOWER DISCHARGE CONVEYOR ASSEMBLY (S.N. UP TO 1110010030)



**LOWER DISCHARGE CONVEYOR ASSEMBLY (S.N. UP TO 1110010030)**

<b>ITEM</b>	<b>PART</b>	<b>QTY.</b>	<b>PART DESCRIPTION</b>
1	1700231	1	BELT\CNVYR\24X606\CLEATED
2	2000303	2	BRG\FLG\1-1/2\BOLT
3	4100030	4	PIN 1" X 3-1/2" HYD. CYL.
4	4502305	1	CONV\LOWER\H1100\FLDNG
5	4502418	1	RLLR\IDLER\32-3/4X8\CNVYR\DISCH
6	4502428	1	TRNSTN\CNVYR\LFT
7	4502429	1	TRNSTN\CNVYR\RHT
8	4701528	1	BRKT\ADJ\TRACKING\CNVYR\DISCH
9	4701529	1	HOOK\ROD\ADJ\BELT\CNVYR\DISCH
10	4704067	2	PL\SEAL\BRG
11	4800003	14	BOLT\HEX\3/8X1
12	4800033	2	BOLT\HEX\3/4X2
13	4800178	8	BOLT\HEX\1/2X1-3/4
14	4800203	8	PIN\COT\5/32X2
15	4800350	1	BOLT\HEX\5/8X2-1/4
16	4900001	8	NUT\HEX\1/2\NC
17	4900002	14	NUT\HEX\3/8\NC
18	4900139	2	NUT\TPLCK\3/4\GR8\NC
19	5000001	28	WASH\FLAT\3/8
20	5000006	8	WASH\LOCK\1/2
21	5000019	14	WASH\LOCK\3/8
22	7501230	2	IDLER\ROLL\2"DIAX4-3/4"
23	4100175	2	CYL\HYD\3X36\PARALLEL
	<b>NOT SHOWN</b>		
	1700142		LCNG\CBL\R-2\24
	1700143		LCNG\R-2\24

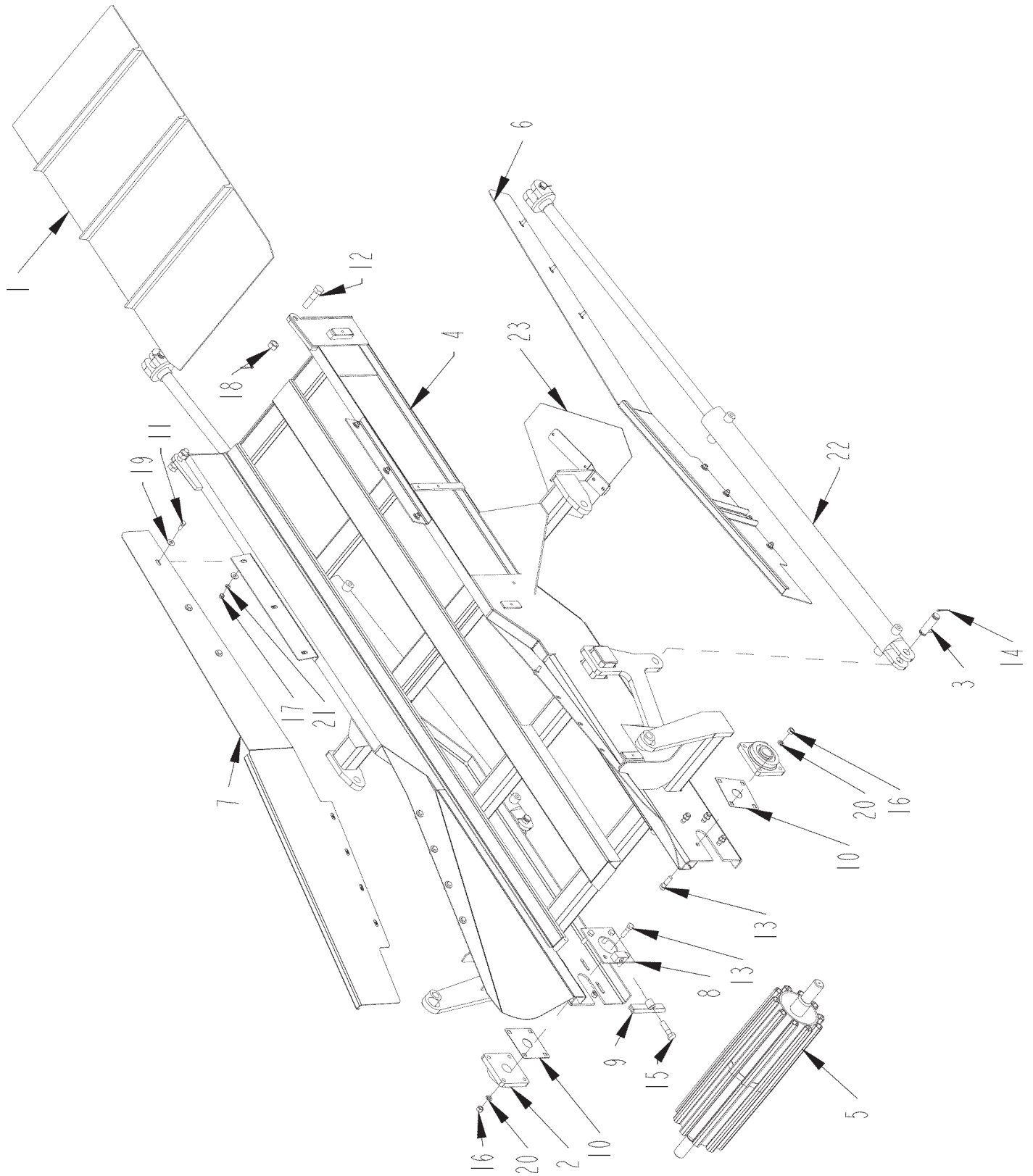
**LOWER DISCHARGE CONVEYOR ASSEMBLY  
(S.N. 1110010130 TO 1113040030)**



**LOWER DISCHARGE CONVEYOR ASSEMBLY  
(S.N. 1110010130 TO 1113040030)**

ITEM	PART	QTY.	PART DESCRIPTION
1	1700231	1	BELT\CNVYR\24X606\CLEATED
2	2000303	2	BRG\FLG\1-1/2\BOLT
3	4100030	4	PIN 1" X 3-1/2" HYD. CYL.
4	4502305	1	CONV\LOWER\H1100\FLDNG
5	4502418	1	RLLR\IDLER\32-3/4X8\CNVYR\DISCH
6	4502428	1	TRNSTN\CNVYR\LFT
7	4502429	1	TRNSTN\CNVYR\RHT
8	4701528	1	BRKT\ADJ\TRACKING\CNVYR\DISCH
9	4701529	1	HOOK\ROD\ADJ\BELT\CNVYR\DISCH
10	4704067	2	PL\SEAL\BRG
11	4800003	14	BOLT\HEX\3/8X1
12	4800017	2	BOLT\HEX\3/4X3
13	4800178	8	BOLT\HEX\1/2X1-3/4
14	4800203	8	PIN\COT\5/32X2
15	4800350	1	BOLT\HEX\5/8X2-1/4
16	4900001	8	NUT\HEX\1/2\NC
17	4900002	14	NUT\HEX\3/8\NC
18	4900139	2	NUT\TPLCK\3/4\GR8\NC
19	5000001	28	WASH\FLAT\3/8
20	5000006	8	WASH\LOCK\1/2
21	5000019	14	WASH\LOCK\3/8
22	7501230	2	IDLER\ROLL\2"DIAX4-3/4"
23	4100175	2	CYL\HYD\3X36\PARALLEL
24	7501353	1	SIGN\SMV\PLSTC-BCKNG
	<b>NOT SHOWN</b>		
	1700142		LCNG\CBL\R-2\24
	1700143		LCNG\R-2\24

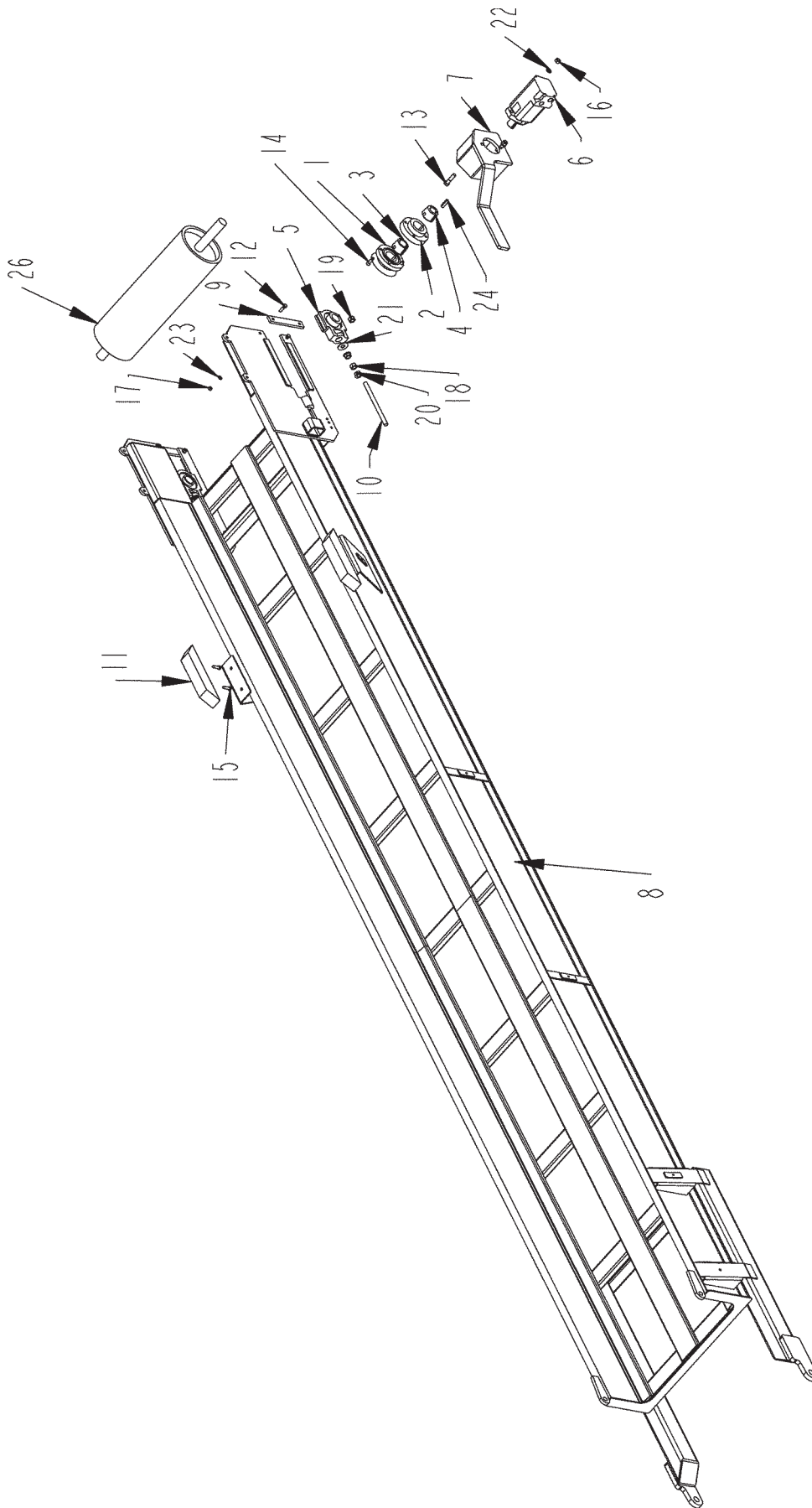
**LOWER DISCHARGE CONVEYOR ASSEMBLY (S.N. 1113040130 AND UP)**



**LOWER DISCHARGE CONVEYOR ASSEMBLY (S.N. 1113040130 AND UP)**

<b>ITEM</b>	<b>PART</b>	<b>QTY.</b>	<b>PART DESCRIPTION</b>
1	1700231	1	BELT\CNVYR\24X606\CLEATED
2	2000303	2	BRG\FLG\1-1/2\BOLT
3	4100030	4	PIN 1" X 3-1/2" HYD. CYL.
4	4502305	1	CONV\LOWER\H1130\FDNG
5	4502418	1	RLLR\IDLER\32-3/4X8\CNVYR\DISCH
6	4502428	1	TRNSTN\CNVYR\LFT
7	4502429	1	TRNSTN\CNVYR\RHT
8	4701528	1	BRKT\ADJ\TRACKING\CNVYR\DISCH
9	4701529	1	HOOK\ROD\ADJ\BELT\CNVYR\DISCH
10	4704067	2	PL\SEAL\BRG
11	4800003	14	BOLT\HEX\3/8X1
12	4801303	2	BOLT\HEX\3/4X2-3/4
13	4800178	8	BOLT\HEX\1/2X1-3/4
14	4800203	8	PIN\COT\5/32X2
15	4800351	1	BOLT\HEX\1/2X2-3/4
16	4900001	8	NUT\HEX\1/2\NC
17	4900002	14	NUT\HEX\3/8\NC
18	4900139	2	NUT\TPLCK\3/4\GR8\NC
19	5000001	28	WASH\FLAT\3/8
20	5000006	8	WASH\LOCK\1/2
21	5000019	14	WASH\LOCK\3/8
22	4100175	2	CYL\HYD\3X36\PARALLEL
23	7501353	1	SIGN\SMV\PLSTC-BCKNG
<b>NOT SHOWN</b>			
	1700142		LCNG\CBL\R-2\24
	1700143		LCNG\R-2\24

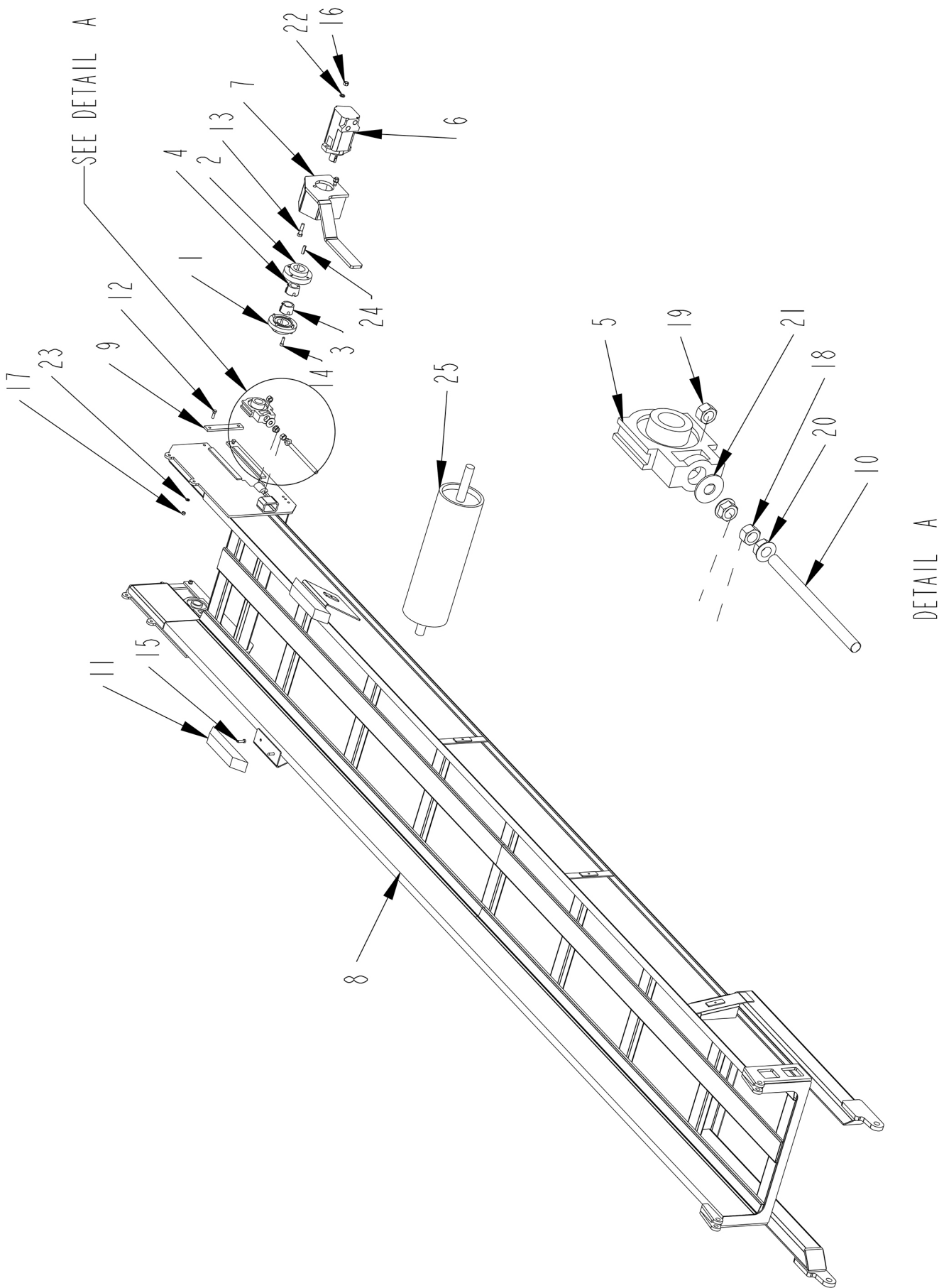
UPPER DISCHARGE CONVEYOR ASSEMBLY (S.N. UP TO 1110010030)



**UPPER DISCHARGE CONVEYOR ASSEMBLY (S.N. UP TO 1110010030)**

<b>ITEM</b>	<b>PART</b>	<b>QTY.</b>	<b>PART DESCRIPTION</b>
1	1400632	1	CPLR\RIGID\MALE\FLANGE\DODGE\003001
2	1400633	1	CPLR\RIGID\FEMALE\FLANGE\DODGE\003002
3	1400634	1	BUSH\TAPER\1-1/2SH\3/8KW\DODGE\119056
4	1400635	1	BUSH\TAPER\1-1/4SH\5/16KW
5	2000320	2	BRG\TUU\1-1/2W-ECC\BSEAL
6	3900014	1	MTR\HYD\9.6\2000\1-1/4SH
7	4502227	1	BRKT\ARM\TORQUE\MTR
8	4502303	1	CONV\UPPER\FLDNG
9	4702204	2	STRAP\REINF\GUIDE\BRG\CNVYR
10	4702205	2	BOLT\ADJ\RLLR\DRV\CNVYR
11	4704099	2	BMPR\CNVYR\DISCH
12	4800098	4	BOLT\HEX\3/8X1-1/4\NC
13	4800114	2	BOLT\HEX\1/2X2
14	4800167	4	SCR\CAP\ALN\3/8X1-1/4\NC
15	4801198	4	SCR\LAG\3/8X1-1/2
16	4900001	2	NUT\HEX\1/2\NC
17	4900002	4	NUT\HEX\3/8\NC
18	4900005	2	NUT\HEX\5/8\NC
19	4900012	2	NUT\TPLCK\5/8\NC
20	4900110	4	NUT\FLG\SERR\5/8\NC
21	5000002	2	WASH\FLAT\5/8
22	5000006	2	WASH\LOCK\1/2
23	5000019	4	WASH\LOCK\3/8
24	6200021	1	KEY\SQ\3/8X1-1/2\HARDEND
26	7501373	1	RLLR\DSCHG\24X8\RBBR

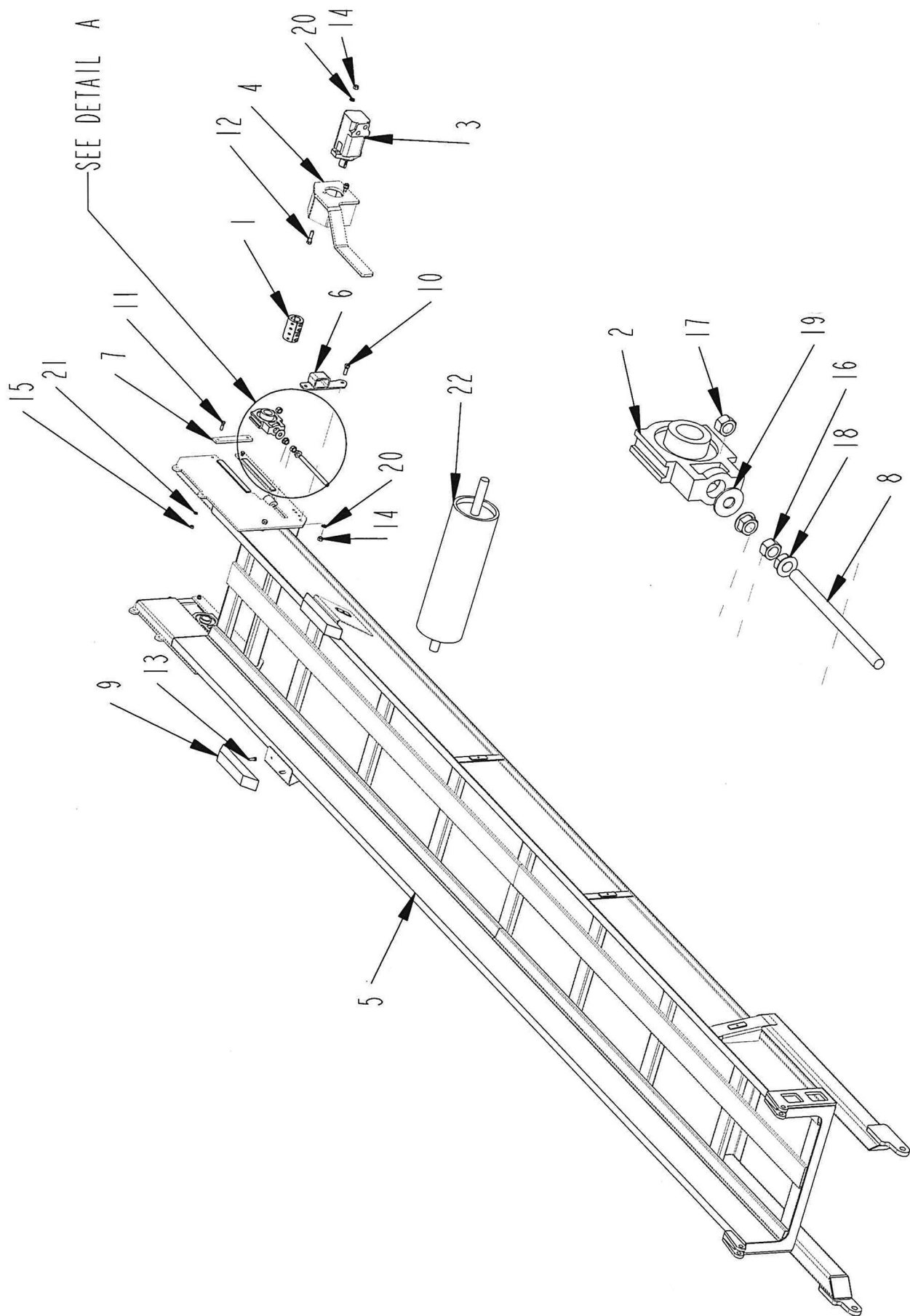
**UPPER DISCHARGE CONVEYOR ASSEMBLY  
(S.N. 1110010030 TO 1117090030)**



**UPPER DISCHARGE CONVEYOR ASSEMBLY  
(S.N. 1110010030 TO 1117090030)**

ITEM	PART	QTY.	PART DESCRIPTION
1	1400632	1	CPLR\RIGID\MALE\FLANGE\DODGE\003001
2	1400633	1	CPLR\RIGID\FEMALE\FLANGE\DODGE\003002
3	1400634	1	BUSH\TAPER\1-1/2SH\3/8KW\DODGE\119056
4	1400635	1	BUSH\TAPER\1-1/4SH\5/16KW
5	2000320	2	BRG\TUJ\1-1/2\W-ECC\BSEAL
6	3900014	1	MTR\HYD\9.6\2000\1-1/4SH
7	4502227	1	BRKT\ARM\TORQUE\MTR
8	4502303	1	CONV\UPPER\FLDNG
9	4702204	2	STRAP\REINFGUIDE\BRG\CNVYR
10	4702205	2	BOLT\ADJ\RLLR\DRV\CNVYR
11	4704099	2	BMPR\CNVYR\DISCH
12	4800098	4	BOLT\HEX\3/8X1-1/4\NC
13	4800114	2	BOLT\HEX\1/2X2
14	4800167	4	SCR\CAP\ALN\3/8X1-1/4\NC
15	4801198	4	SCR\LAG\3/8X1-1/2
16	4900001	2	NUT\HEX\1/2\NC
17	4900002	4	NUT\HEX\3/8\NC
18	4900005	2	NUT\HEX\5/8\NC
19	4900012	2	NUT\TPLCK\5/8\NC
20	4900110	4	NUT\FLG\SERR\5/8\NC
21	5000002	2	WASH\FLAT\5/8
22	5000006	2	WASH\LOCK\1/2
23	5000019	4	WASH\LOCK\3/8
24	6200021	1	KEY\SQ\3/8X1-1/2\HARDEND
25	7501373	1	RLLR\DSCHG\24X8\RBBR

UPPER DISCHARGE CONVEYOR ASSEMBLY (S.N. 1118090130 AND UP)



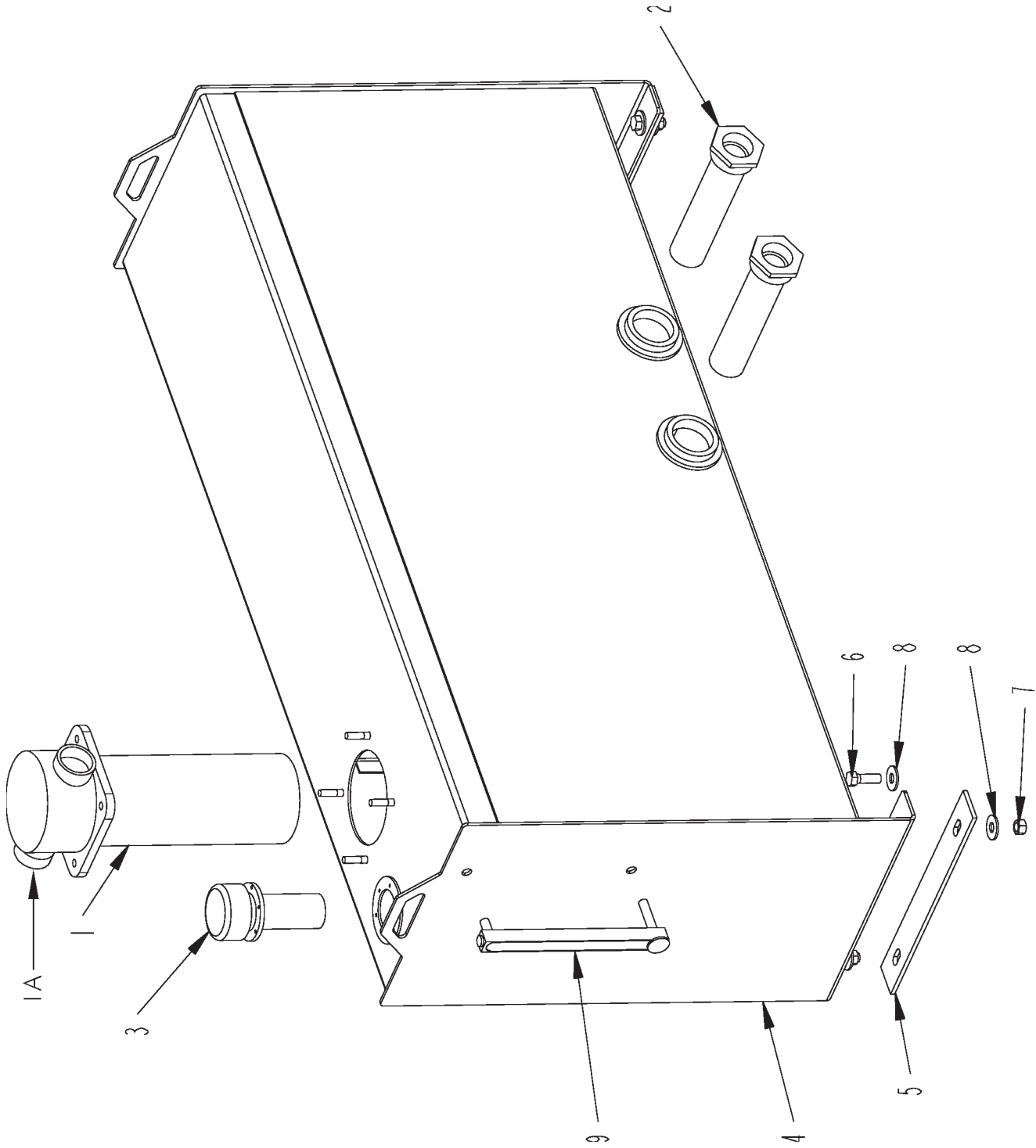
SEE DETAIL A

DETAIL A  
SCALE 1/8

**UPPER DISCHARGE CONVEYOR ASSEMBLY (S.N. 1118090130 AND UP)**

<b>ITEM</b>	<b>PART</b>	<b>QTY.</b>	<b>PART DESCRIPTION</b>
1	1400659	1	CPLR\RIGID\1.5X1.25
2	2000320	2	BRG\TUU\1-1/2\W-ECC\BSEAL
3	3900014	1	MTR\HYD\9.6\2000\1-1/4SH
4	4502227	1	BRKT\ARM\TORQUE\MTR
5	4502303	1	CONV\UPPER\FDNG
6	4502811	1	BRKT\ARM\TORQUE
7	4702204	2	STRAP\REIN\FGUIDE\BRG\CNVYR
8	4702205	2	BOLT\ADJ\RLLR\DRV\CNVYR
9	4704099	2	BMPR\CNVYR\DISCH
10	4800082	2	BOLT\HEX\1/2X1-1/2
11	4800098	4	BOLT\HEX\3/8X1-1/4\NC
12	4800114	2	BOLT\HEX\1/2X2
13	4801198	4	SCR\LAG\3/8X1-1/2
14	4900001	4	NUT\HEX\1/2\NC
15	4900002	4	NUT\HEX\3/8\NC
16	4900005	2	NUT\HEX\5/8\NC
17	4900012	2	NUT\TPLCK\5/8\NC
18	4900110	4	NUT\FLG\SERR\5/8\NC
19	5000002	2	WASH\FLAT\5/8
20	5000006	4	WASH\LOCK\1/2
21	5000019	4	WASH\LOCK\3/8
22	7501373	1	RLLR\DSCHG\24X8\RBBR

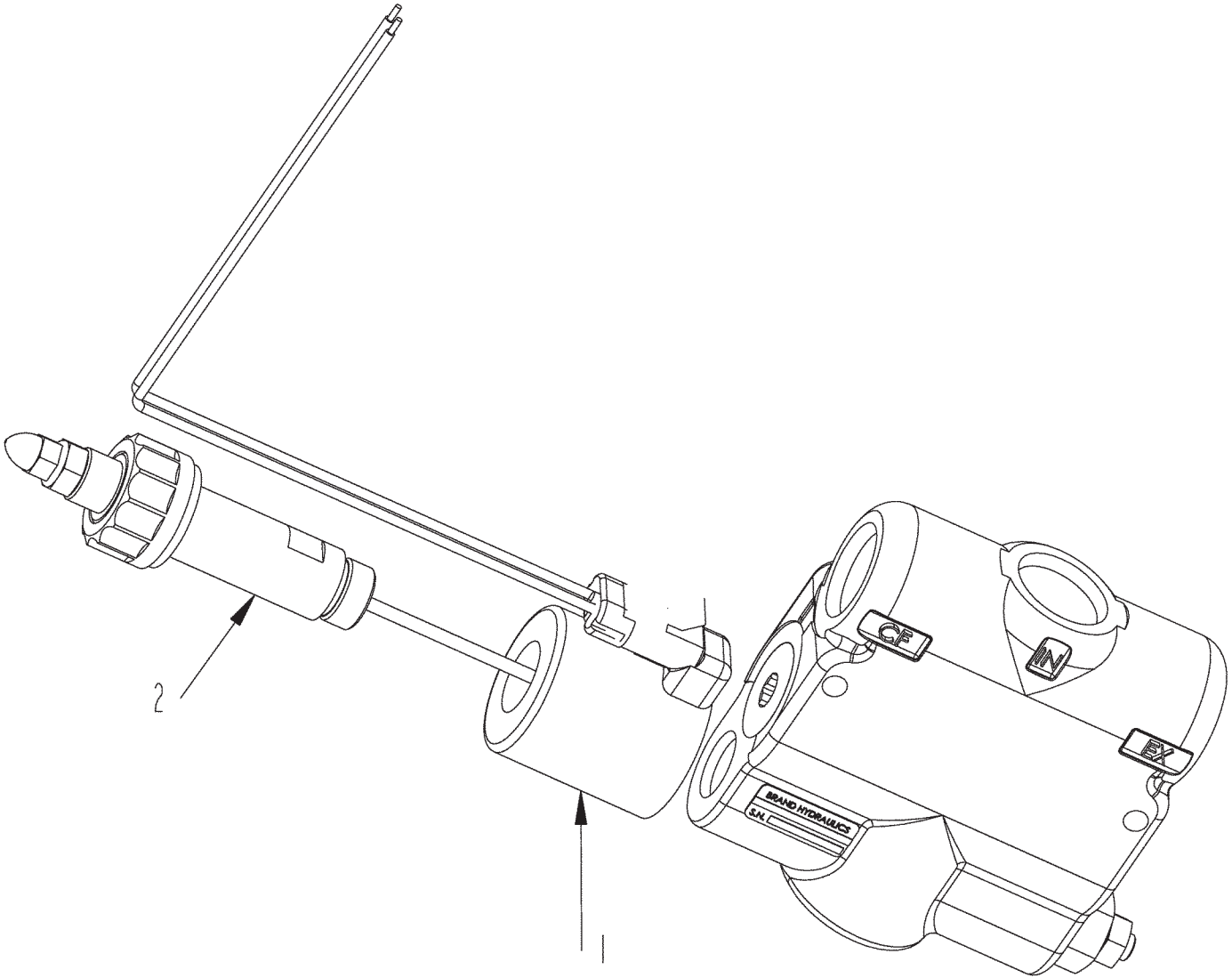
# HYDRAULIC OIL TANK ASSEMBLY



## HYDRAULIC OIL TANK ASSEMBLY

ITEM	PART	QTY.	PART DESCRIPTION
1	4400043	1	FILTER\HYDRAULIC\RETURN\IN-TANK ELEMENT 4400074
1A	4400066		GAUGE\FLTR\25PSI\1/8NPTF\COLOR CODED
2	4400067	2	FLTR\SCRN\2-1/2MORX1-7/8FOR\30GPM\ST30-100-RV3
3	4400071	1	VENT\W\LOCK\CAP\HYD
4	4502412	1	TANK\OIL\60GAL
5	4502424	2	BELT\CUSH\TNK\OIL\60GAL
6	4800082	4	BOLT\HEX\1/2X1-1/2
7	4900014	4	NUT\TPLCK\1/2\NC
8	5000004	8	WASH\FLAT\1/2
9	7500615	1	GAUGE\LEVEL\10\W\THERMOMETER
	<b>4502349</b>		<b>TANK\OIL\ASSY\H1130</b>
	<b>WEAR PART</b>		
	4400074		FLTR\ELMT\10MIC\INTANK (replacement filter)
	4400158		O-RING\2.337IDX.116\BUNA\AS568-932
	4400159		GASKET\NECK\4400071
	4400160		GASKET\CAP\4400071
	7501587		O-RING\5/8IDX3/32\BUNA90\AS568-114

**4300078 SERVO 5 GPM VALVE**



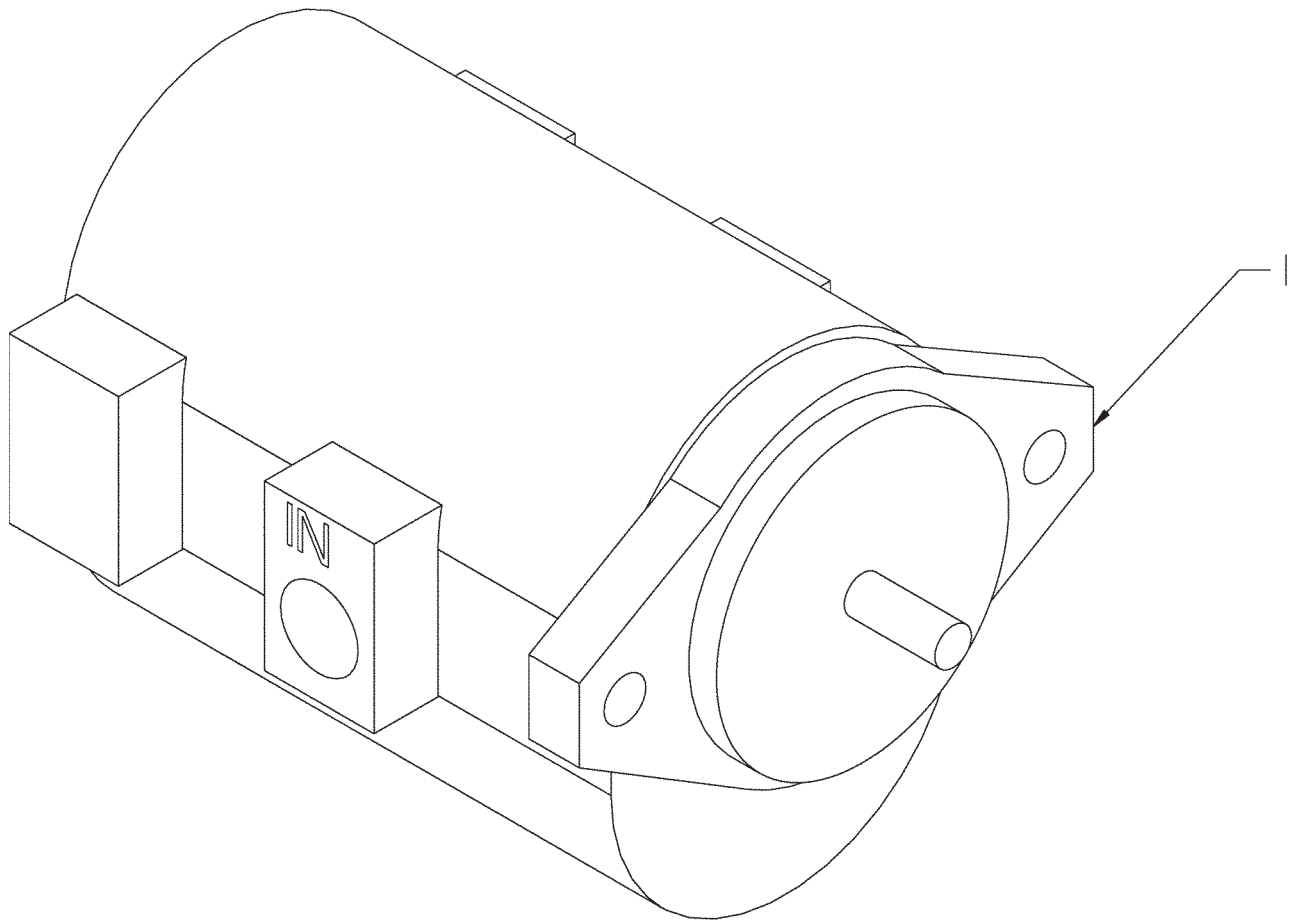
ITEM	PART NO.	QTY.	PART DESCRIPTION
1	4000460	1	VALVE\HYD\SOL\12V\C961
2	4000464	1	TUBE\COIL\ASSY\W\PUSHROD

**NOT SHOWN**

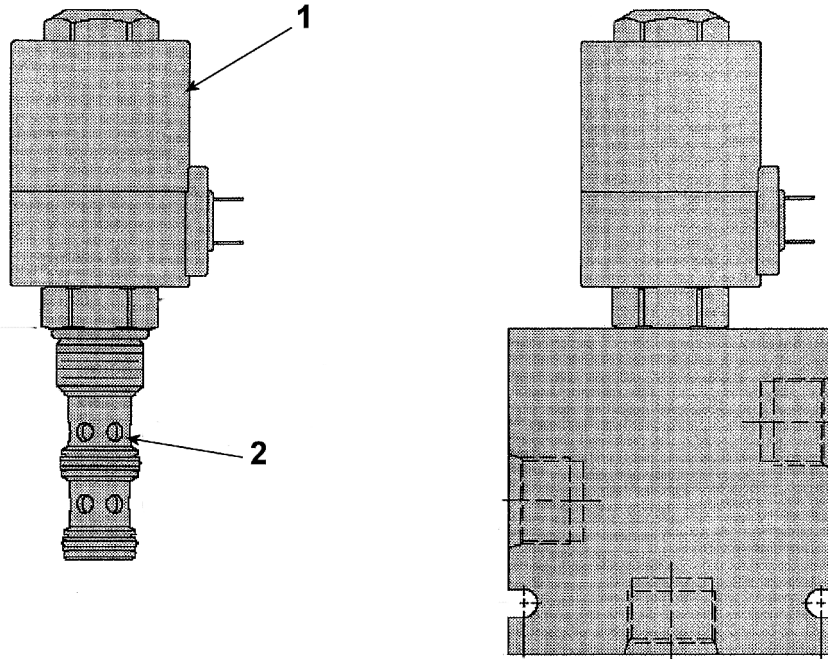
4300077	KIT\SEAL\VL\SERVO\BRAND
4300072	VALVE\SERVO\30GPM\24VOLT
4300074	VALVE\SOLENOID\24V\BRAND

# TANDUM HYDRAULIC PUMP

ITEM	PART NO.	QTY.	PART DESCRIPTION
1	4200142	1	PUMP\HYD\TNDM\1.78CIDX1.3CID
	4200161		PUMP\SEALKIT4200142



**4000429 HYDRAULIC SOLENOID VALVE**

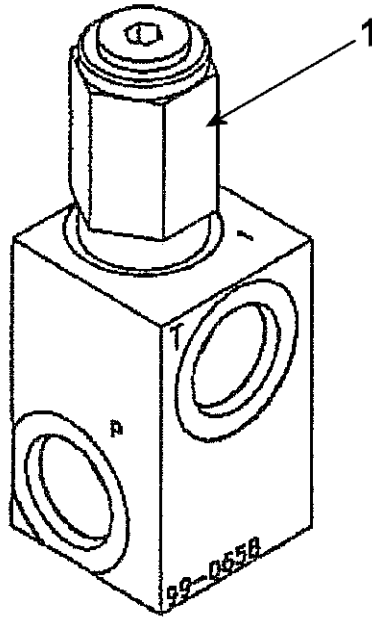


**4000429**

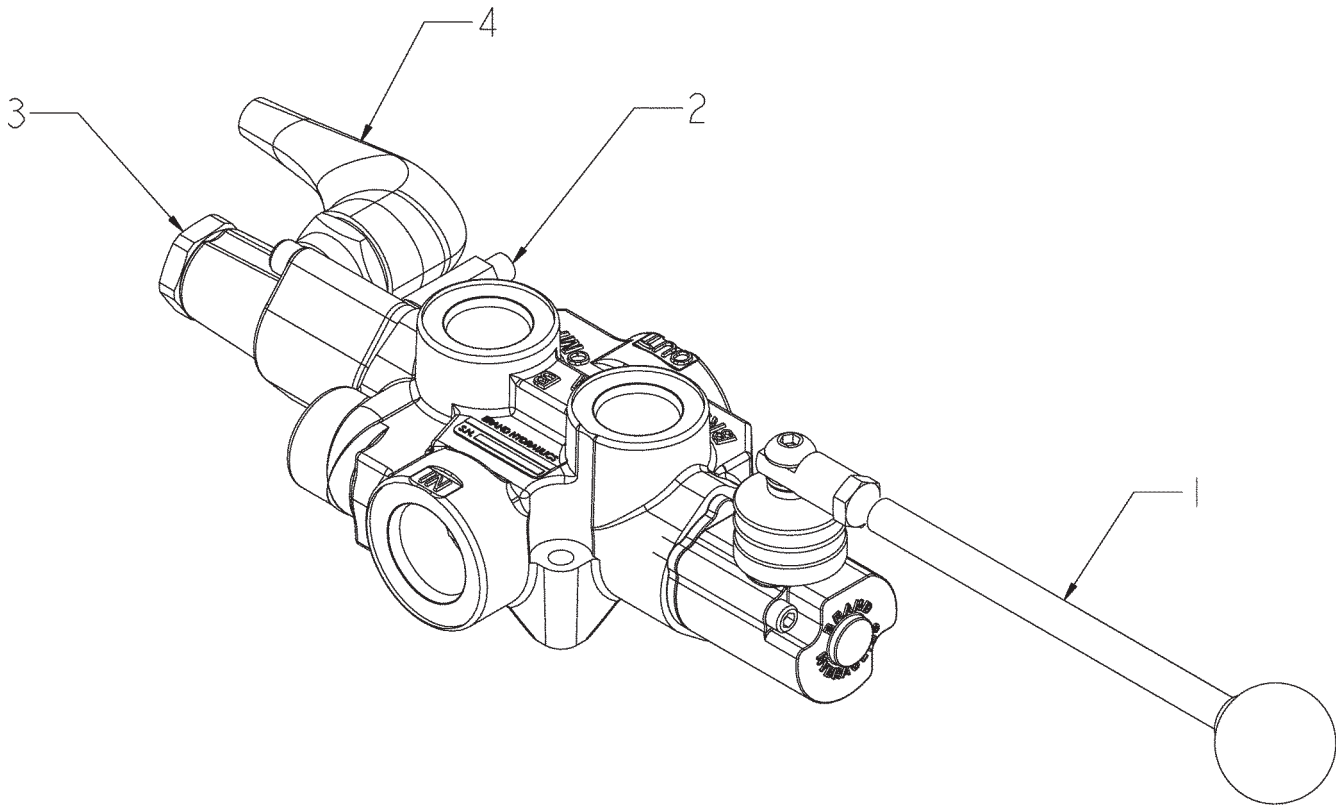
ITEM	PART NO.	QTY.	PART DESCRIPTION
	4000429	1	VALVE\HYD\SOL\12V\2POS\3WAY
1	4000459	1	VALVE\HYD\SOL\12V\12\DTZW/DIODE
2	4000461	1	SPOOL\VALVE\HYD\2POS\3WAY

# 4000430 RELIEF VALVE

ITEM	PART NO.	QTY.	PART DESCRIPTION
	4000430	1	VALVE\RELIEF\3000PSI
1	4000462	1	VALVE\HYD\CART\RELIEF\35/30



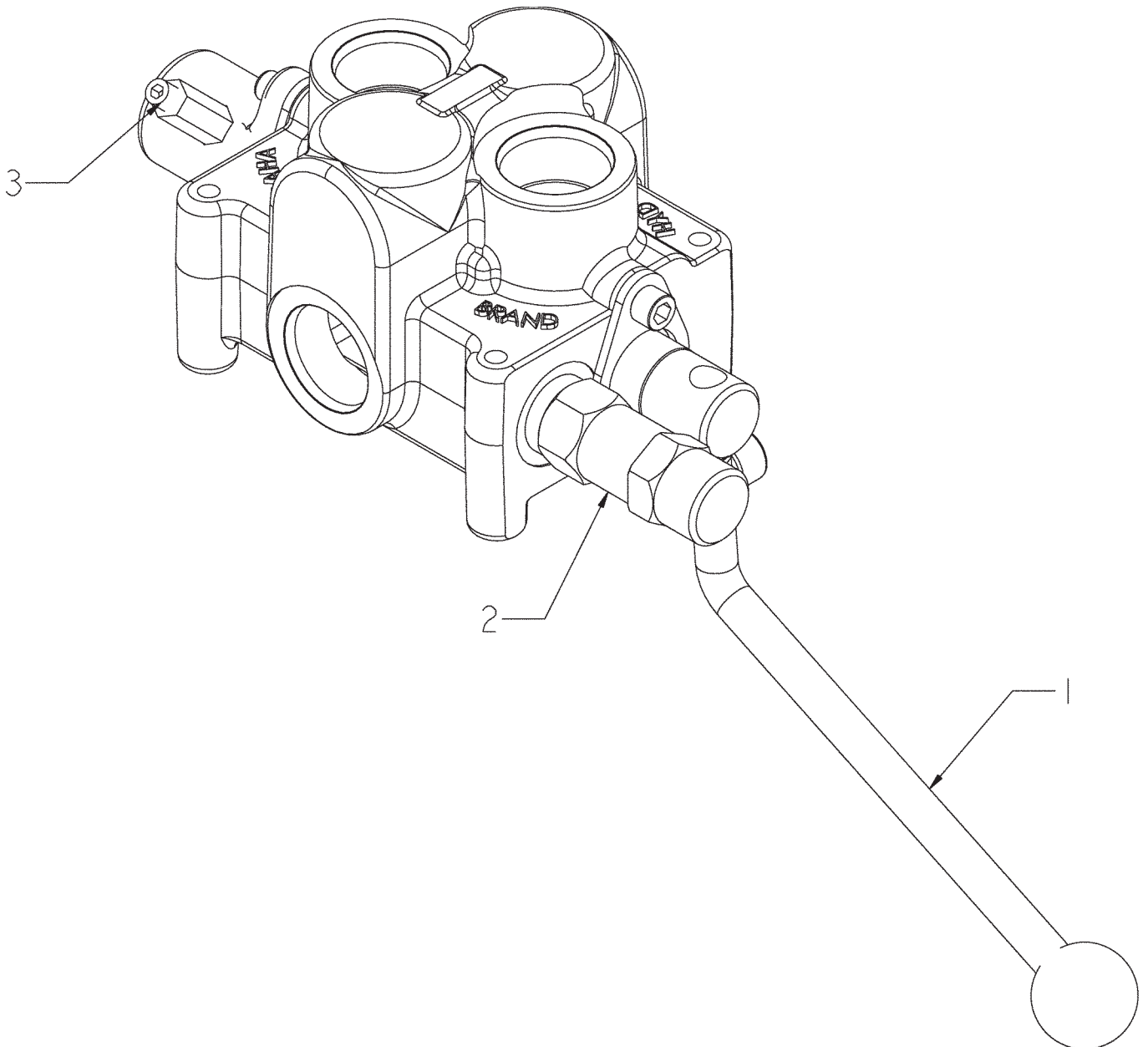
**4300431 3-POS 4-WAY HYDRAULIC VALVE**



ITEM	PART NO.	QTY.	PART DESCRIPTION
	4000431		VALVE\HYD\OC\3POS\4WAY\W\NOSWTCH
1	4000465	1	HANDLE\KIT\VLV\HYD\A012004CDWO
2	4000467	1	KIT\DETENT\VLV\AO12004CDWO
3	5700905	1	SWITCH\VALVE\HYD
4	5700906	1	BOOT\CVR\SWITCH\VLV
	4000466		KIT\SEAL\VLV\AO12004CDWO

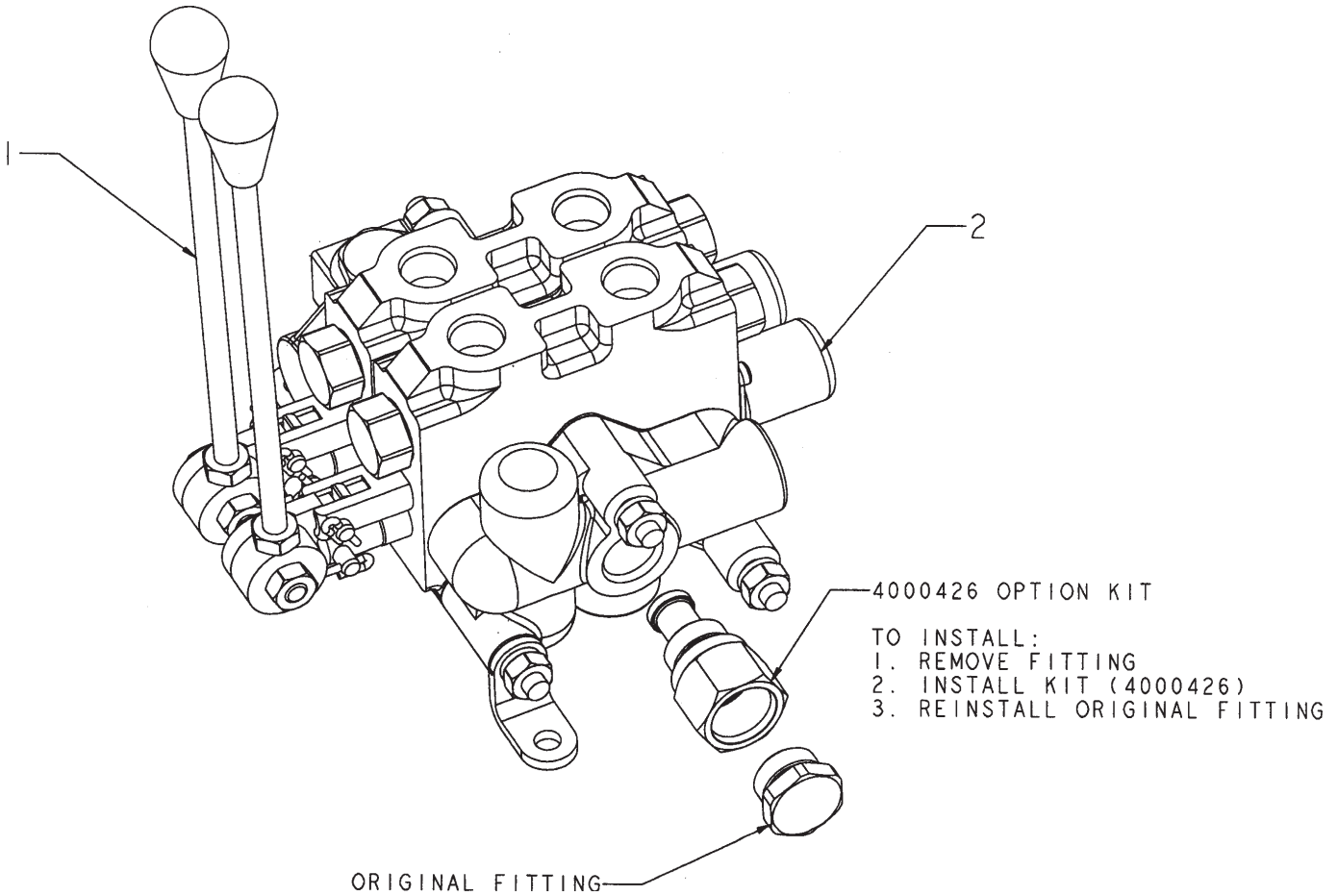
**4300432 2-POS 4-WAY HYDRAULIC VALVE**

ITEM	PART NO.	QTY.	PART DESCRIPTION
	4000432	1	VALVE\HYD\OC\2POS\4WAY\45GPM
1	4000468	1	HANDLE\KIT\VLV\DC1604LB2DPSY1
2	4000470	1	CRTRDG\RELIEF\VLV\DC16\2500
3	4000471	1	KIT\DETENT\VLV\DC1604LB2DPSY1
	4000469	1	KIT\SEAL\VLV\HYD\DC1604LB2DPSY1

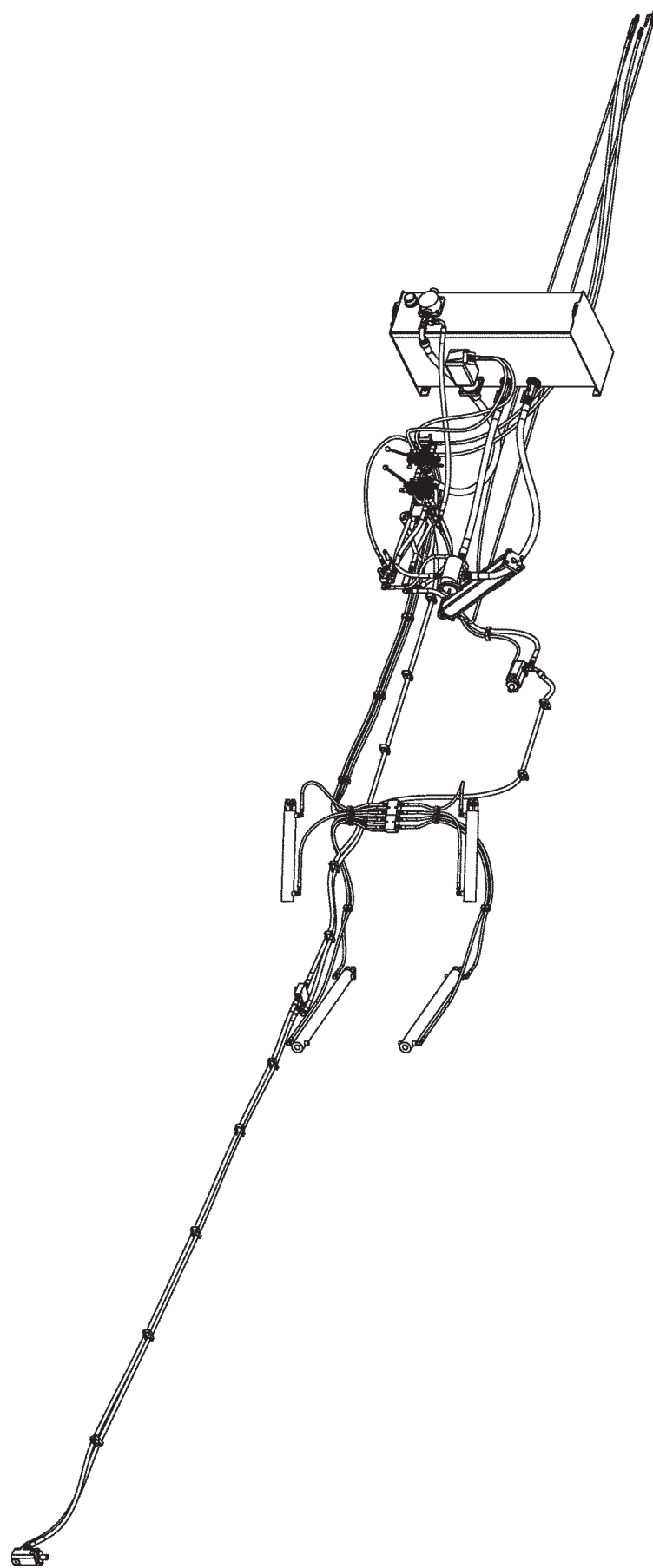


## 4000423 2-BANK HYDRAULIC VALVE

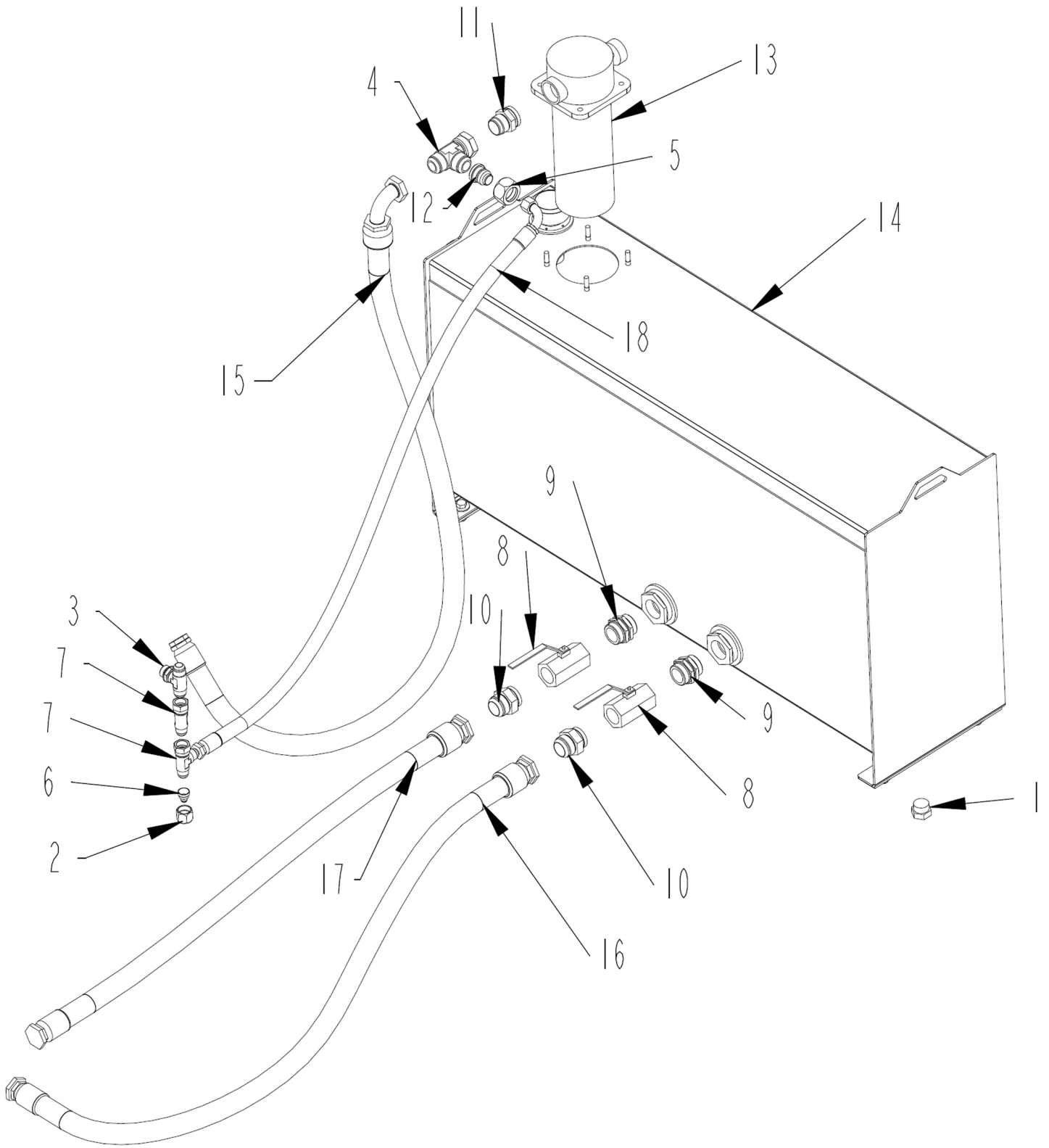
ITEM	PART	QTY	DESCRIPTION
	<b>4000423</b>		<b>VLV\HYD\2BANK</b>
1	4000472	1	HANDLE\KIT\VLV\HYD\34SERIES
2	4000474	1	KIT\SPRING\CENTER\34SERIES
	4000426	OPTION	FTG\PLUG\CLOSED CENTER ( <b>OPTION KIT</b> )
	4000473	1	KIT\SEAT\LOCK\LOAD
	4000537		VALVE\HYD\REPLACE\LOAD;LOCK\STEEL
	4000538		VALVE\HYD\CART\LOAD;LOCK\STEEL



# MACHINE HYDRAULICS SCHEMATIC



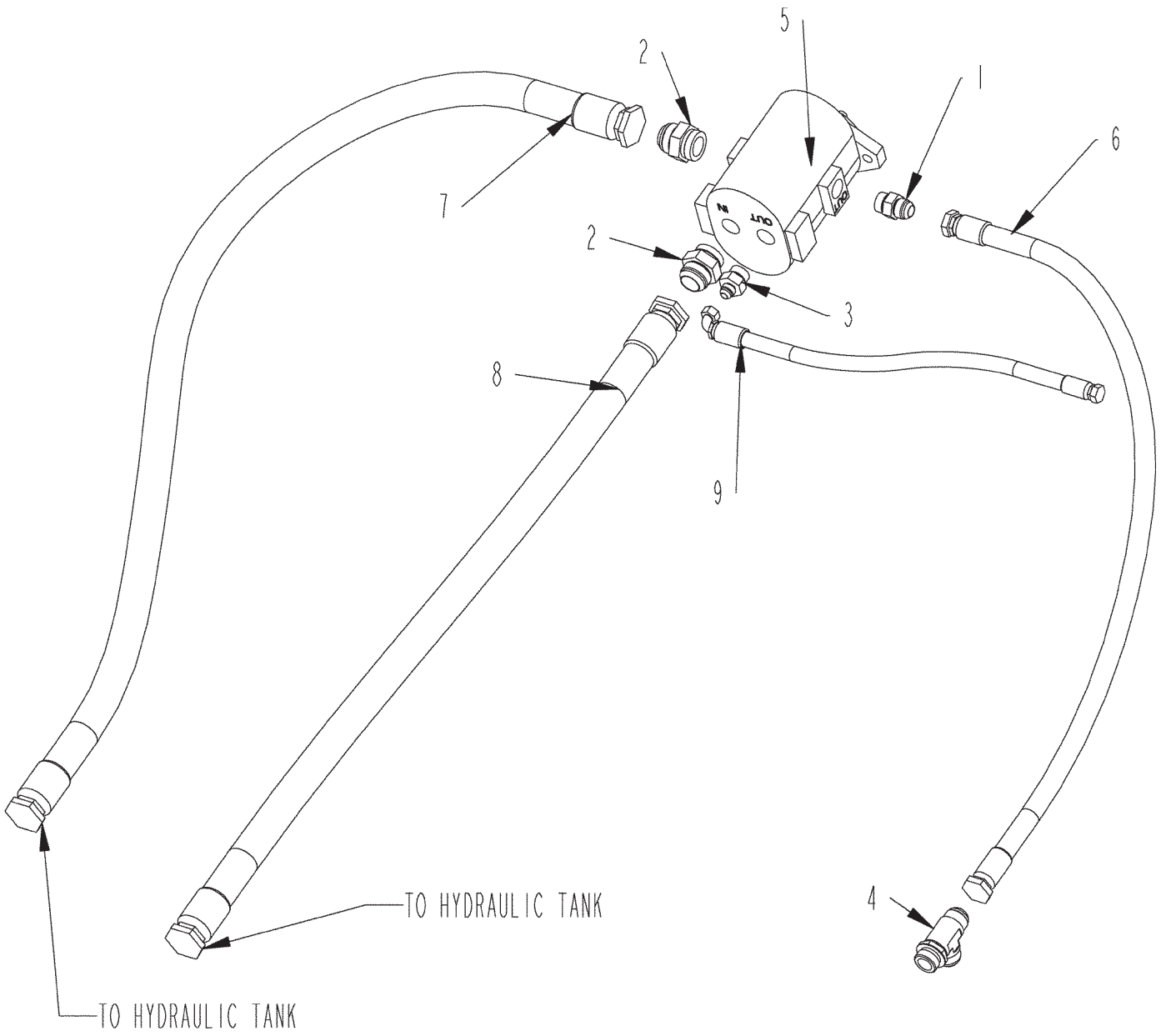
# OIL TANK HYDRAULICS



## OIL TANK HYDRAULICS

ITEM	PART	QTY.	PART DESCRIPTION
1	3800301	1	FTG\1-5/16MOR\PLUG\HEX
2	3800462	1	FTG\1-1/16NUTFJICS
3	3800481	1	FTG\1-1/16MJICX1-1/16MJICX1-1/16MOR\BR;TEE
4	3800486	1	FTG\1-5/8FJICX1-5/8MJICX1-5/8MJIC\RUN;TEE
5	3800488	1	FTG\1-5/8NUTFJICS
6	3800542	1	FTG\1-1/16FJICX9/16MJIC\ADPT
7	3800670	2	FTG\1-1/16FJICX1-1/16MJICX1-1/16MJIC\RUN;TEE
8	3800740	2	VALVE\BALL\1-1/2\1-7/8FOR\1/4 TURN\W/LOCK
9	3800745	2	FTG\1-7/8MORX1-7/8MOR\ADPT
10	3800746	2	FTG\1-7/8MORX1-7/8MJIC\ST
11	3800808	1	FTG\1-7/8MORX1-5/8MJIC\ST
12	3800840	1	FTG\1-5/8FJICX1-5/16MJIC\ADPT
13	4400043	1	FILTER\HYDRAULIC\RETURN\IN-TANK ELEMENT 4400074
13a	4400066		GAUGE\FLTR\25PSI\1/8NPTF\COLOR CODED
14	4502349	1	TNK\OIL\H1100
15	3700973	1	HOSE\HYD\1-1/4X65\1-5/16FJICX1-5/8FJC90DEG TANK PORT CONVEYOR VALVE TO FILTER
16	3701551	1	HOSE\HYD\1-1/2X82\1-7/8FJICX1-5/8FJIC SUPPLY PORT (HIGH VOLUME PUMP) TO RIGHT TANK PORT SCREEN
17	3701552	1	HOSE\HYD\1-1/2X59\1-7/8FJICX1-5/8FJIC SUPPLY PORT (LOW VOLUME PUMP) TO LEFT TANK PORT SCREEN
18	3700981	1	HOSE\HYD\3/4X68\1-1/16FJICX1-1/16FJIC\90 BRANCH OF LOWER TEE'S PORT 3 SELECTOR VALVE TO BRANCH OF TEE ON FILTER

# TANDUM PUMP HYDRAULICS



**TANDUM PUMP HYDRAULICS**

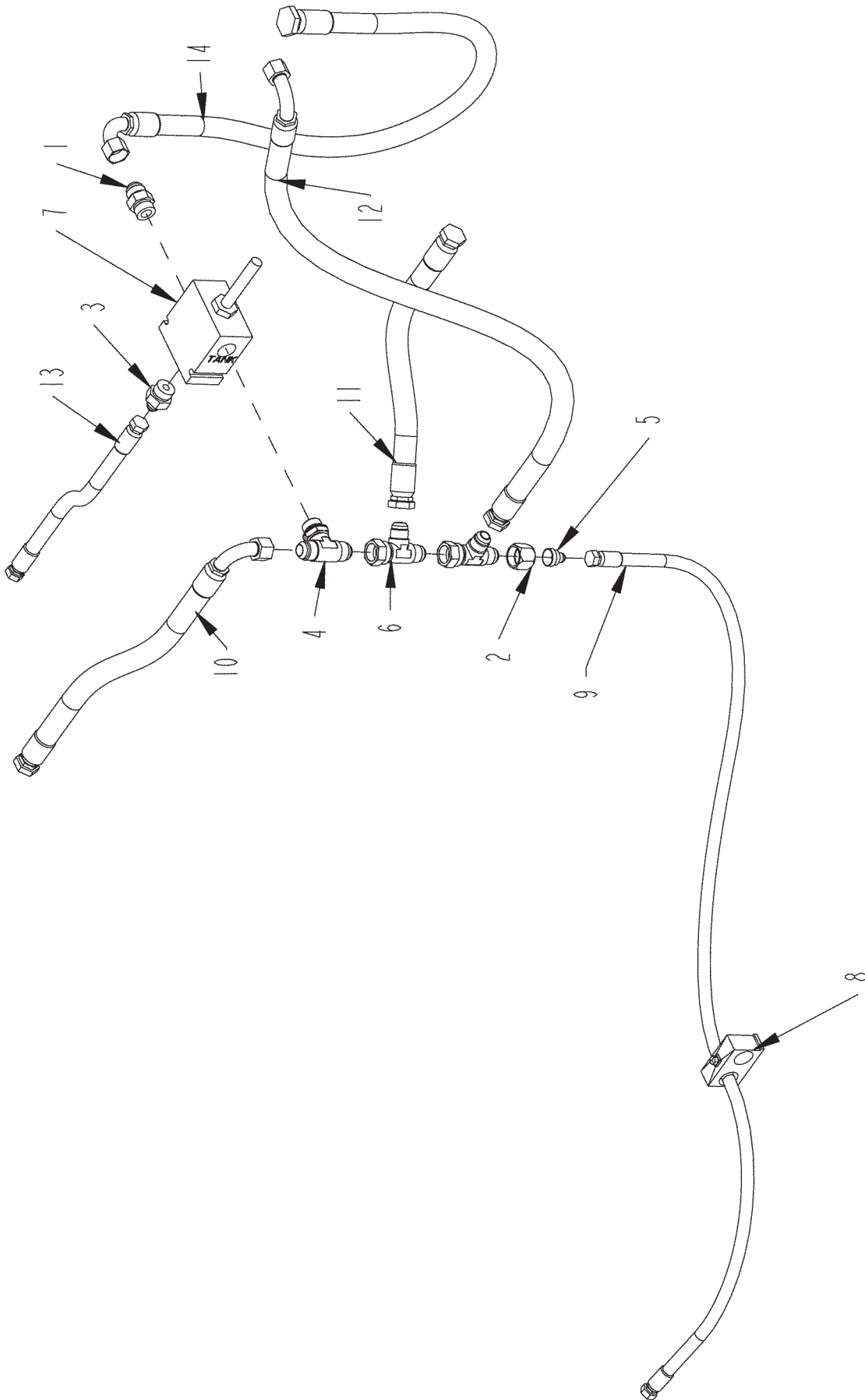
<b>ITEM</b>	<b>PART</b>	<b>QTY.</b>	<b>PART DESCRIPTION</b>
1	3800277	1	FTG\1-1/16MORX1-1/16MJIC\ST
2	3800470	2	FTG\1-5/8MORX1-5/8MJIC\ST
3	3800480	1	FTG\1-1/16MORX3/4MJIC\ADPT
4	3800842	1	FTG\1-5/16MORX1-5/16MJCX1-5/16MJIC\RUN;TEE
5	4200142	1	PUMP\HYD\TNDM\1.78CIDX1.3CID
6	3700974	1	HOSE\HYD\3/4X56\1-5/16FJICX1-1/16FJIC PRESSURE PORT (HIGH VOLUME PUMP) TO TEE ON IN PORT CONVEYOR VALVE
7	3700975	1	HOSE\HYD\1-1/4X82\1-5/8FJICX1-5/8FJIC SUPPLY PORT (HIGH VOLUME PUMP) TO RIGHT TANK PORT SCREEN
8	3700976	1	HOSE\HYD\1-1/4X59\1-5/8FJICX1-5/8FJIC SUPPLY PORT (LOW VOLUME PUMP) TO LEFT TANK PORT SCREEN
9	3700977	1	HOSE\HYD\1/2X23\3/4FJICX3/4FJIC\90 PRESSURE PORT (LOW VOLUME PUMP) TO PORT RELIEF VALVE ON TUB FLOW CONTROL



## TUB FLOW CONTROL HYDRAULICS

ITEM	PART	QTY.	PART DESCRIPTION
1	3800279	1	FTG\1-1/16MORX1-1/16MJIC\90
2	3800462	1	FTG\1-1/16NUTFJICS
3	3800481	1	FTG\1-1/16MJICX1-1/16MJICX1-1/16MOR\BR;TEE
4	3800536	3	FTG\1-1/16MORX3/4MJIC\90
5	3800542	1	FTG\1-1/16FJICX9/16MJIC\ADPT
6	3800670	2	FTG\1-1/16FJICX1-1/16MJICX1-1/16MJIC\RUN;TEE
7	3800939	1	FTG\1-1/16MORX1-1/16MOR\ADPT
8	4000430	1	VALVE\RELIEF\3000PSI
9	4300078	1	VALVE\SERVO\15GPM\12V
10	3700977	1	HOSE\HYD\1/2X23\3/4FJICX3/4FJIC\90 PRESSURE PORT (LOW VOLUME PUMP) TO P PORT RELIEF VALVE ON TUB FLOW CONTROL
11	3700978	1	HOSE\HYD\3/4X26\1-1/16FJICX1-1/16FJIC\90 T PORT RELIEF VALVE (TUB FLOW CONTROL) TO PORT 3 SELECTOR VALVE
12	3700980	1	HOSE\HYD\1/2X 50\3/4FJICX3/4FJIC CF PORT TUB FLOW CONTROL TO IN PORT OF TUB VALVE
13	3700982	1	HOSE\HYD\1/2X 20\3/4FJICX3/4FJIC EX PORT TUB FLOW CONTROL VALVE TO PORT 1 SELECTOR VALVE

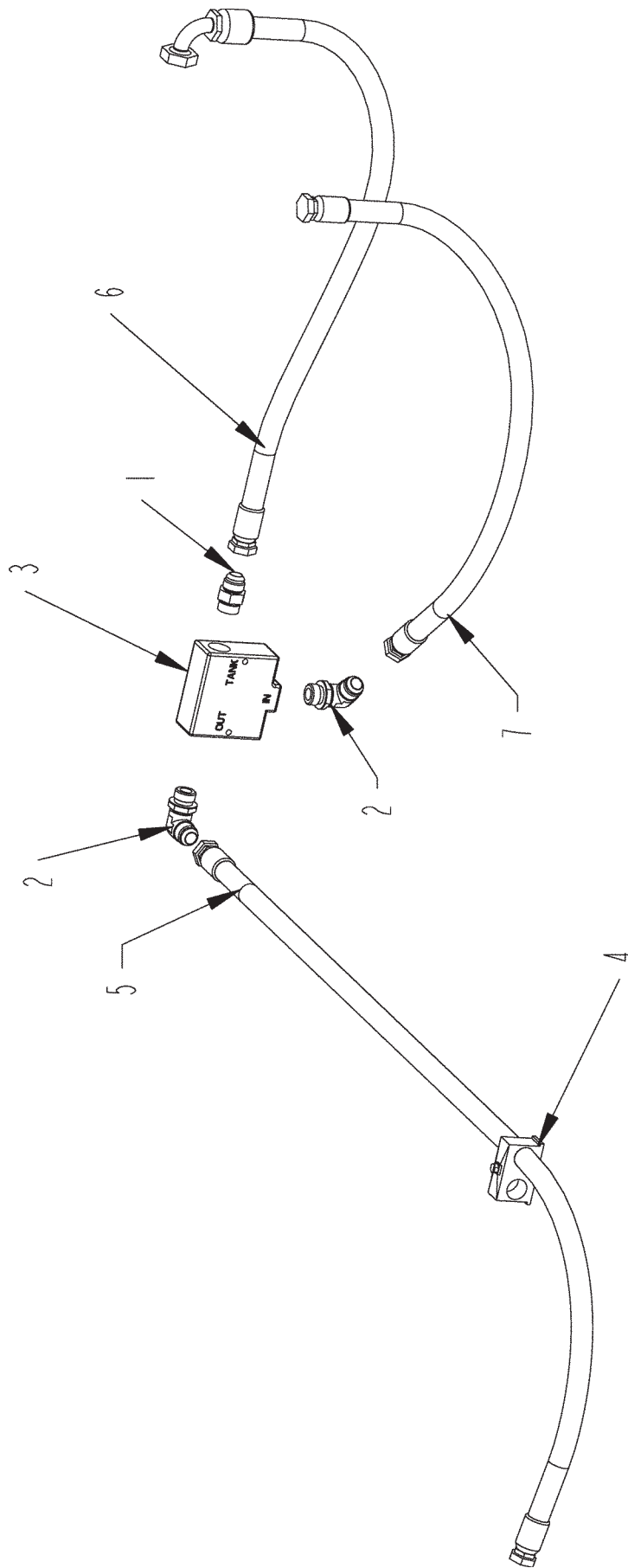
# SOLENOID HYDRAULIC VALVE



**SOLENOID HYDRAULIC VALVE**

<b>ITEM</b>	<b>PART</b>	<b>QTY.</b>	<b>PART DESCRIPTION</b>
1	3800277	1	FTG\1-1/16MORX1-1/16MJIC\ST
2	3800462	1	FTG\1-1/16NUTFJICS
3	3800480	1	FTG\1-1/16MORX3/4MJIC\ADPT
4	3800481	1	FTG\1-1/16MJICX1-1/16MJICX1-1/16MOR\BR;TEE
5	3800542	1	FTG\1-1/16FJICX9/16MJIC\ADPT
6	3800670	2	FTG\1-1/16FJICX1-1/16MJICX1-1/16MJIC\RUN;TEE
7	4000429	1	VALVE\HYD\SOL\12V\2POS\3WAY
8	7501337	1	CLMP\HOSE\CUSH\3/8
9	3700971	1	HOSE\HYD\3/8X63\9/16FJICS CASE DRAIN ON AUGER ORBIT TO RUN OF RETURN TEE'S
10	3700978	1	HOSE\HYD\3/4X26\1-1/16FJICX1-1/16FJIC\90 T PORT RELIEF VALVE (TUB FLOW CONTROL) TO PORT 3 SELECTOR VALVE
11	3700979	1	HOSE\HYD\3/4X19\1-1/16FJICX1-1/16FJIC BRANCH OF MIDDLE TEE'S PORT 3 SELECTOR VALVE TO OUT PORT OF TUB VALVE
12	3700981	1	HOSE\HYD\3/4X68\1-1/16FJICX1-1/16FJIC\90 BRANCH OF LOWER TEE'S PORT 3 SECLECTOR VALVE TO BRANCH OF TEE ON FILTER
13	3700982	1	HOSE\HYD\1/2X 20\3/4FJICX3/4FJIC EX PORT TUB FLOW CONTROL TO PORT 1 SELECTOR VALVE
14	3700983	1	HOSE\HYD\3/4X32\1-1/16FJC90X1-5/16FJC PORT 2 SELECTOR VALVE TO BRANCH OF TEE ON IN PORT CONVEYOR VALVE

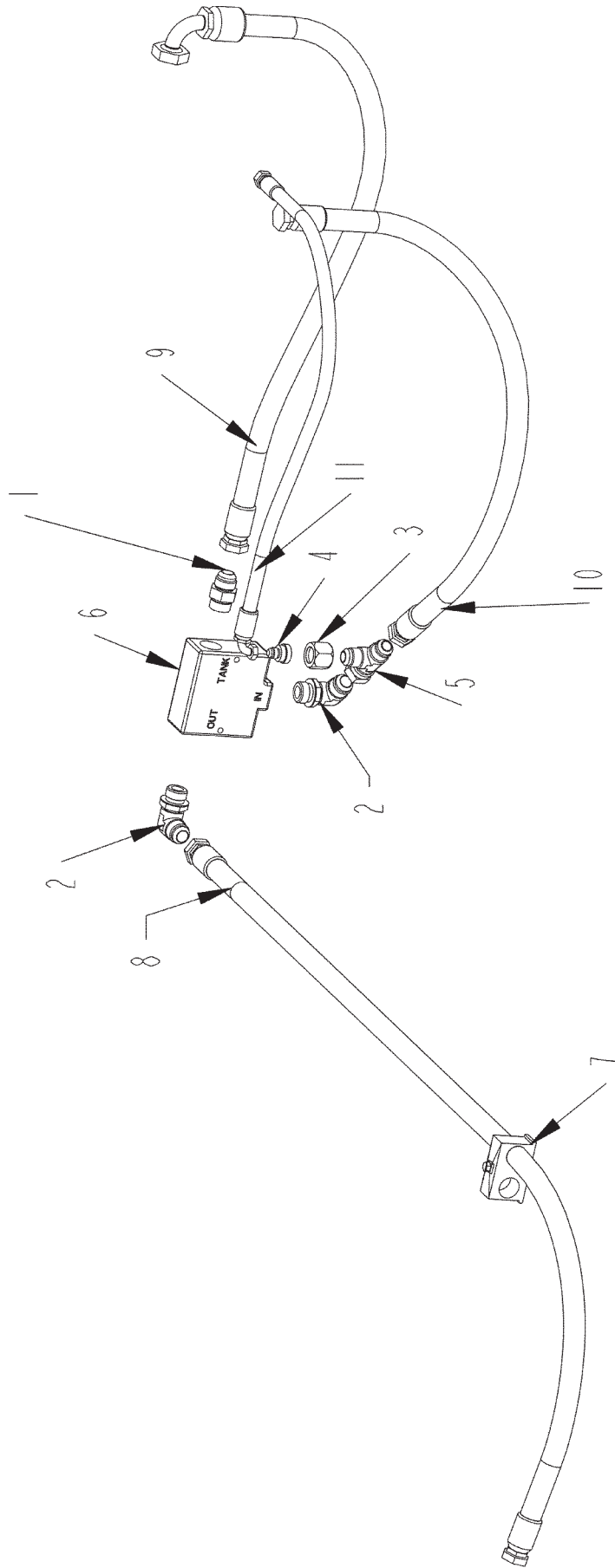
**FIXED FLOW CONTROL VALVE HYDRAULICS (S.N. UP TO 1110010030)**



**FIXED FLOW CONTROL VALVE HYDRAULICS (S.N. UP TO 1110010030)**

<b>ITEM</b>	<b>PART</b>	<b>QTY.</b>	<b>PART DESCRIPTION</b>
1	3800277	1	FTG\1-1/16MORX1-1/16MJIC\ST
2	3800279	2	FTG\1-1/16MORX1-1/16MJIC\90
3	4000428	1	VLV\HYD\CNTRL\FLW\24GPM
4	7501337	1	CLMP\HOSE\CUSH\3/8
5	3700969	1	HOSE\HYD\3/4X60\1-1/16FJCX1-1/16FJC PORT B AUGER ORBIT TO CF PORT FIXED FLOW CONTROL VALVE
6	3700970	1	HOSE\HYD\3/4X46\1-1/16FJICX1-5/16FJIC\90 TANK PORT OF FIXED FLOW CONTROL TO BRANCH OF TEE ON CONVEYOR VALVE TANK PORT
7	3700972	1	HOSE\HYD\3/4X37\1-1/16FJCX1-1/16FJC P PORT FIXED FLOW CONTROL VALVE TO B PORT CONVEYOR VALVE

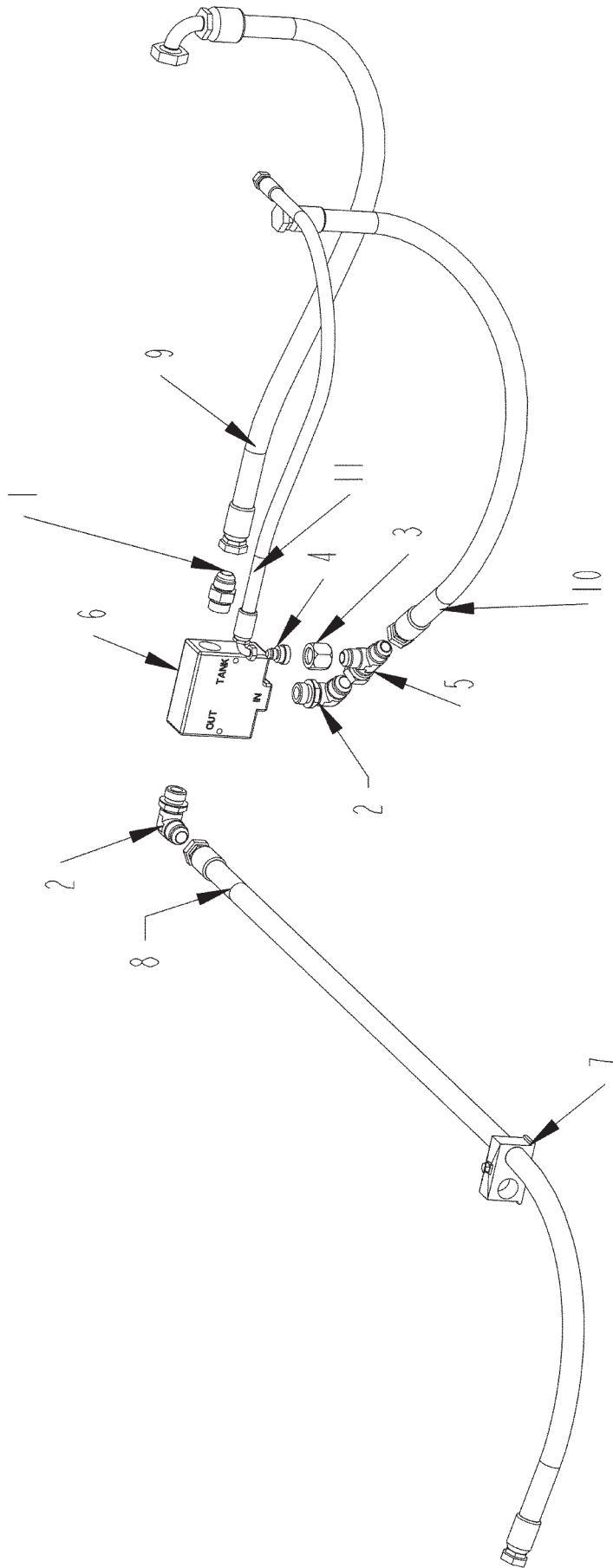
**FIXED FLOW CONTROL VALVE HYDRAULICS  
(S.N. 1110010130 TO 1113040030)**



**FIXED FLOW CONTROL VALVE HYDRAULICS  
(S.N. 1110010130 TO 1113040030)**

ITEM	PART	QTY.	PART DESCRIPTION
1	3800277	1	FTG\1-1/16MORX1-1/16MJIC\ST
2	3800279	2	FTG\1-1/16MORX1-1/16MJIC\90
3	3800462	1	FTG\1-1/16NUTFJICS
4	3800542	1	FTG\1-1/16FJICX9/16MJIC\ADPT
5	3800670	1	FTG\1-1/16FJICX1-1/16MJICX1-1/16MJIC\RUN;TEE
6	4000428	1	VLV\HYD\CNTRL\FLW\24GPM
7	7501337	1	CLMP\HOSE\CUSH\3/8
8	3700969	1	HOSE\HYD\3/4X60\1-1/16FJICX1-1/16FJC PORT B AUGER ORBIT TO CF PORT FIXED FLOW CONTROL VALVE
9	3700970	1	HOSE\HYD\3/4X46\1-1/16FJICX1-5/16FJIC\90 TANK PORT OF FIXED FLOW CONTROL TO BRANCH OF TEE ON CONVEYOR VALVE TANK PORT
10	3700972	1	HOSE\HYD\3/4X37\1-1/16FJICX1-1/16FJC P PORT FIXED FLOW CONTROL VALVE TO B PORT CONVEYOR VALVE
11	3701059	1	HOSE\HYD\3/8X37\9/16FJICX9/16FJC90 REAR STEM CONVEYOR PRESSURE GAUGE TO IN PORT FIXED FLOW CONTROL

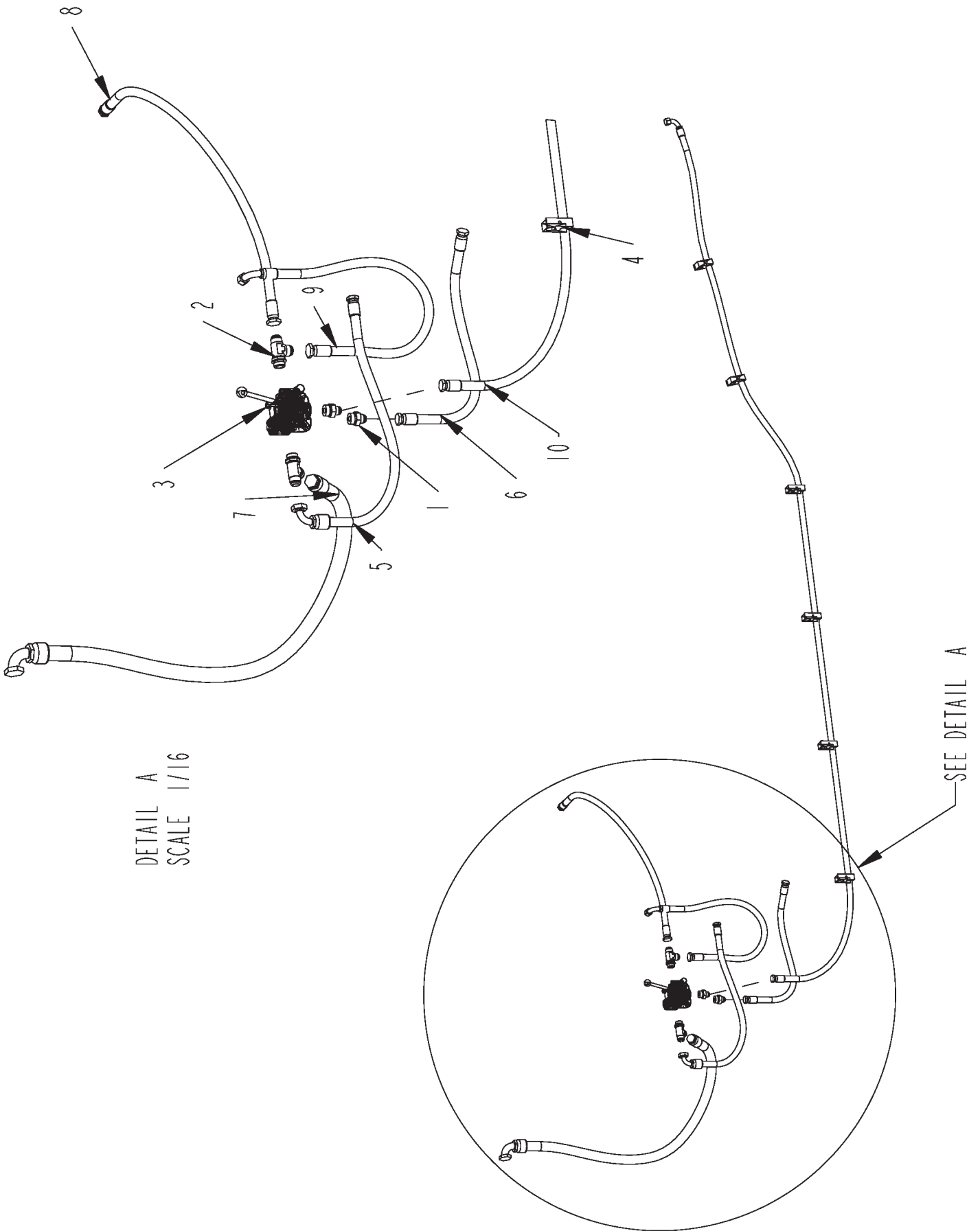
**FIXED FLOW CONTROL VALVE HYDRAULICS (S.N. 1113040130 AND UP)**



**FIXED FLOW CONTROL VALVE HYDRAULICS (S.N. 1113040130 AND UP)**

<b>ITEM</b>	<b>PART</b>	<b>QTY.</b>	<b>PART DESCRIPTION</b>
1	3800277	1	FTG\1-1/16MORX1-1/16MJIC\ST
2	3800279	2	FTG\1-1/16MORX1-1/16MJIC\90
3	3800462	1	FTG\1-1/16NUTFJICS
4	3800542	1	FTG\1-1/16FJICX9/16MJIC\ADPT
5	3800670	1	FTG\1-1/16FJICX1-1/16MJICX1-1/16MJIC\RUN;TEE
6	4000428	1	VLV\HYD\CNTRL\FLW\24GPM
7	7501337	1	CLMP\HOSE\CUSH\3/8
8	3701187	1	HOSE\HYD\3/4X35\1-1/16FJC90X1-1/16FJC PORT B AUGER ORBIT TO CF PORT FIXED FLOW CONTROL VALVE
9	3700970	1	HOSE\HYD\3/4X46\1-1/16FJICX1-5/16FJIC\90 TANK PORT OF FIXED FLOW CONTROL TO BRANCH OF TEE ON CONVEYOR VALVE TANK PORT
10	3700972	1	HOSE\HYD\3/4X37\1-1/16FJICX1-1/16FJC P PORT FIXED FLOW CONTROL VALVE TO B PORT CONVEYOR VALVE
11	3701059	1	HOSE\HYD\3/8X37\9/16FJICX9/16FJC90 REAR STEM CONVEYOR PRESSURE GAUGE TO IN PORT FIXED FLOW CONTROL

# CONVEYOR ON/OFF VALVE HYDRAULICS



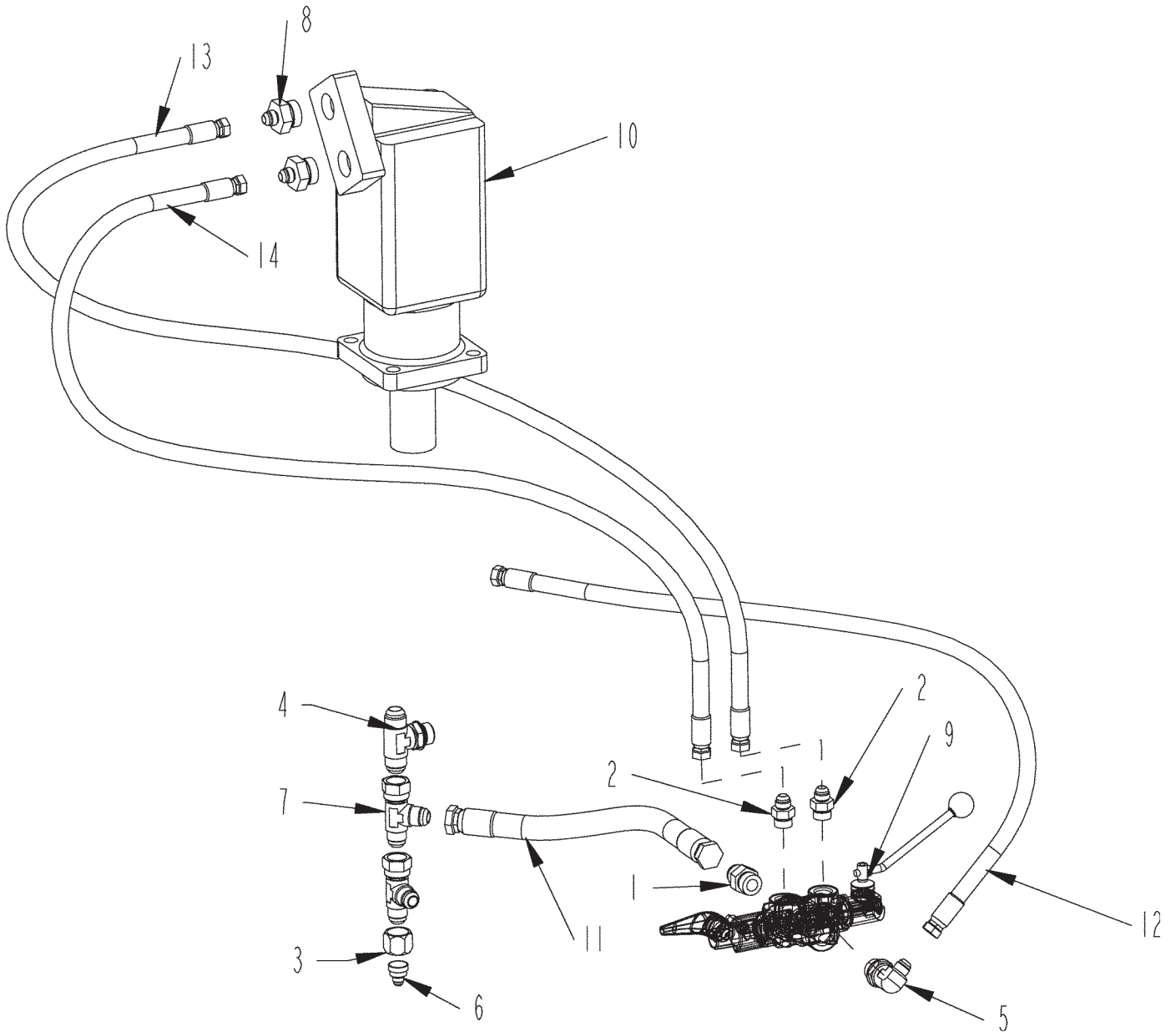
DETAIL A  
SCALE 1/16

SEE DETAIL A

**CONVEYOR ON/OFF VALVE HYDRAULICS**

<b>ITEM</b>	<b>PART</b>	<b>QTY.</b>	<b>PART DESCRIPTION</b>
1	3800526	2	FTG\1-5/16MORX1-1/16MJIC\ST
2	3800842	2	FTG\1-5/16MORX1-5/16MJCX1-5/16MJIC\RUN;TEE
3	4000432	1	VALVE\HYD\OC\2POS\4WAY\45GPM
4	7501337	6	CLMP\HOSE\CUSH\3/8
5	3700970	1	HOSE\HYD\3/4X46\1-1/16FJICX1-5/16FJIC\90 TANK PORT OF FIXED FLOW CONTROL TO BRANCH OF TEE ON CONVEYOR VALVE TANK PORT
6	3700972	1	HOSE\HYD\3/4X37\1-1/16FJICX1-1/16FJC P PORT FIXED FLOW CONTROL VALVE TO B PORT CONVEYOR VALVE
7	3700973	1	HOSE\HYD\1-1/4X65\1-5/16FJICX1-5/8FJC90DEG TANK PORT CONVEYOR VALVE TO FILTER ON TANK
8	3700974	1	HOSE\HYD\3/4X56\1-5/16FJICX1-1/16FJC PRESSURE PORT (HIGH VOLUME PUMP) TO TEE ON IN PORT CONVEYOR VALVE
9	3700983	1	HOSE\HYD\3/4X32\1-1/16FJC90X1-5/16FJC PORT 2 SELECTOE VALVE TO BRANCH OF TEE ON IN PORT CONVEYOR VALVE
10	3700993	1	HOSE\HYD\3/4X202\1-1/16FJC90X1-1/16FJC EX PORT DISCHARGE CONVEYOR FLOW CONTROL TO PORT A CONVEYOR VALVE

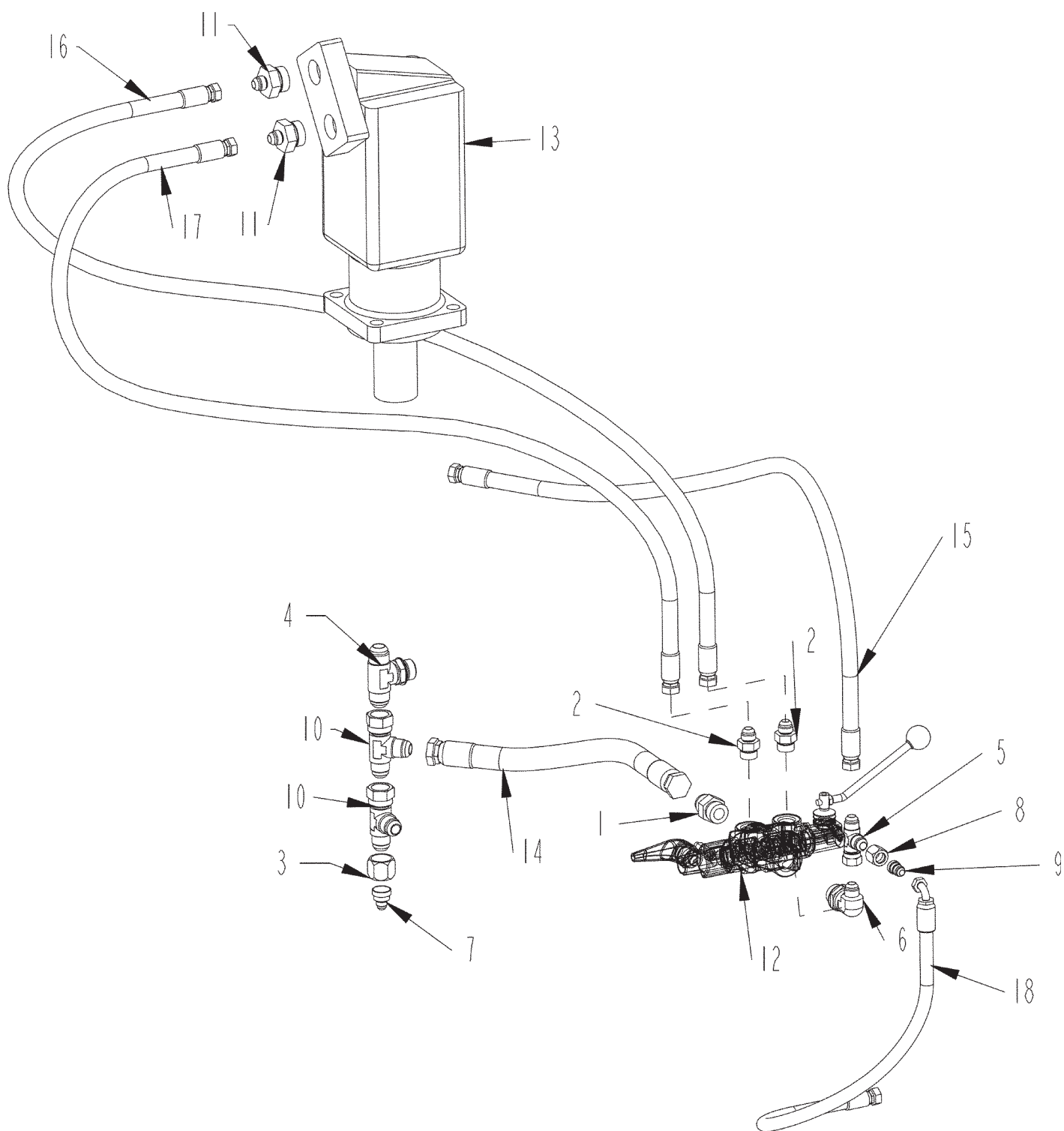
TUB ROTATION VALVE AND TUB ORBIT MOTOR (S.N. UP TO 1110010030)



**TUB ROTATION VALVE AND TUB ORBIT MOTOR (S.N. UP TO 1110010030)**

<b>ITEM</b>	<b>PART</b>	<b>QTY.</b>	<b>PART DESCRIPTION</b>
1	3800277	1	FTG\1-1/16MORX1-1/16MJIC\ST
2	3800328	2	FTG\7/8MORX3/4MJIC\ADPT
3	3800462	1	FTG\1-1/16NUTFJICS
4	3800481	1	FTG\1-1/16MJICX1-1/16MJICX1-1/16MOR\BR;TEE
5	3800536	1	FTG\1-1/16MORX3/4MJIC\90
6	3800542	1	FTG\1-1/16FJICX9/16MJIC\ADPT
7	3800670	2	FTG\1-1/16FJICX1-1/16MJICX1-1/16MJIC\RUN;TEE
8	3800938	2	FTG\1-5/16MORX3/4MJIC\ADPT
9	4000431	1	VALVE\HYD\3POS\4WAY\OC\NOSWTCH
10	4200121	1	MTR\HYD\40.6\1000\2-1/4\1-5/16FOR
11	3700979	1	HOSE\HYD\3/4X19\1-1/16FJICX1-1/16FJIC BRANCH OF MIDDLE TEE'S PORT 3 SELECTOR VALVE TO OUT PORT OF TUB VALVE
12	3700980	1	HOSE\HYD\1/2X 50\3/4FJICX3/4FJIC CF PORT TUB FLOW CONTROL TO IN PORT OF TUB VALVE
13	3700984	1	HOSE\HYD\1/2X 137\3/4FJICX3/4FJIC PORT A TUB VALVE TO UPPER PORT TUB ORBIT MOTOR
14	3700984	1	HOSE\HYD\1/2X 137\3/4FJICX3/4FJIC PORT B TUB VALVE TO LOWER PORT TUB ORBIT MOTOR
	<b>NOT SHOWN</b>		
	4700777	3	CLMP\HOSE\1/2\PLATED

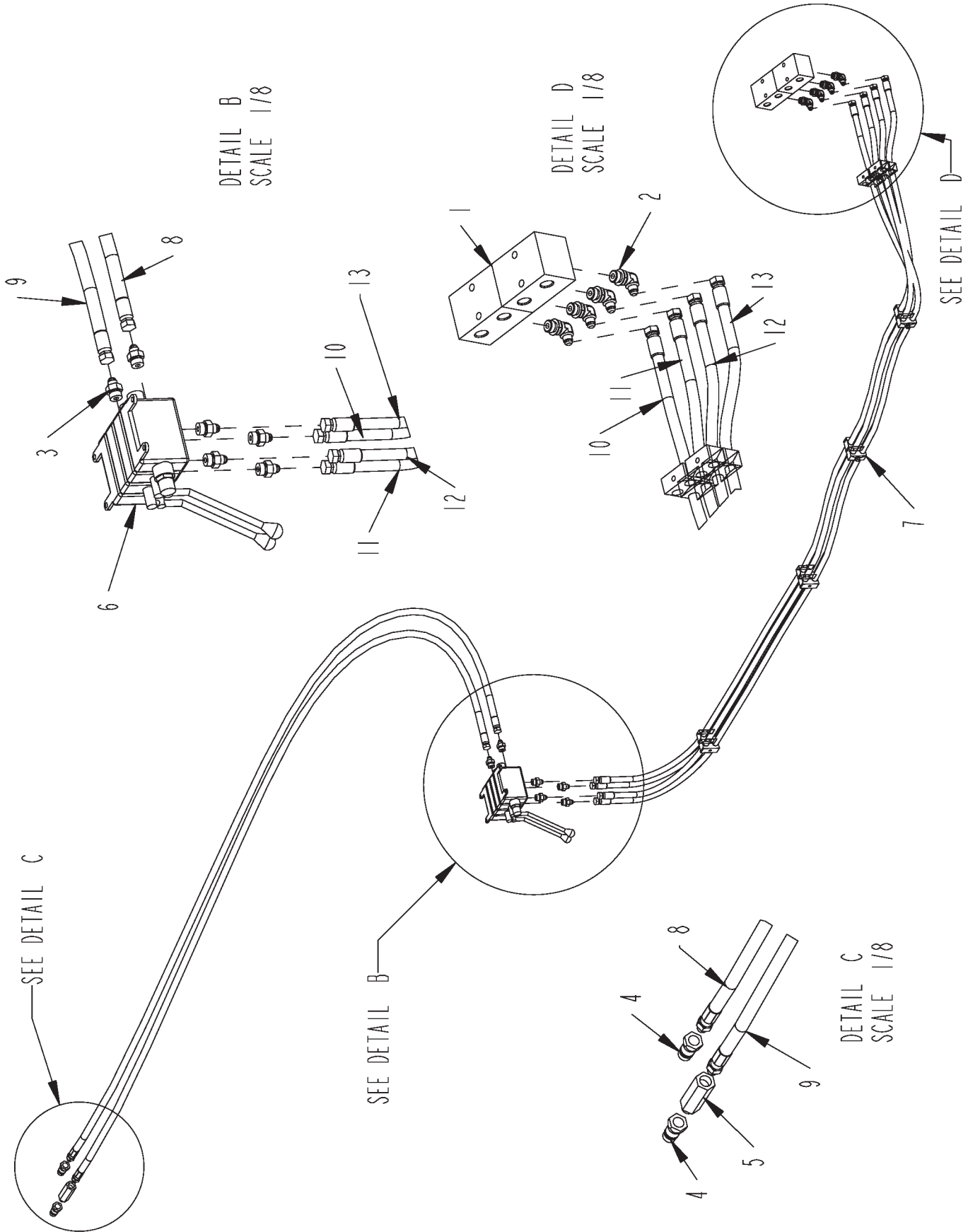
TUB ROTATION VALVE AND TUB ORBIT MOTOR (S.N. 1110010130 AND UP)



**TUB ROTATION VALVE AND TUB ORBIT MOTOR (S.N. 1110010130 AND UP)**

<b>ITEM</b>	<b>PART</b>	<b>QTY.</b>	<b>PART DESCRIPTION</b>
1	3800277	1	FTG\1-1/16MORX1-1/16MJIC\ST
2	3800328	2	FTG\7/8MORX3/4MJIC\ADPT
3	3800462	1	FTG\1-1/16NUTFJICS
4	3800481	1	FTG\1-1/16MJICX1-1/16MJICX1-1/16MOR\BR;TEE
5	3800484	1	FTG\3/4FJICSX3/4MJICX3/4MJIC\RUN;TEE
6	3800536	1	FTG\1-1/16MORX3/4MJIC\90
7	3800542	1	FTG\1-1/16FJICX9/16MJIC\ADPT
8	3800549	1	FTG\3/4NUTFJIC
9	3800587	1	FTG\3/4FJICX9/16MJIC\ADPT
10	3800670	2	FTG\1-1/16FJICX1-1/16MJICX1-1/16MJIC\RUN;TEE
11	3800938	2	FTG\1-5/16MORX3/4MJIC\ADPT
12	4000431	1	VALVE\HYD\3POS\4WAY\OC\NOSWTCH
13	4200121	1	MTR\HYD\40.6\1000\2-1/4\1-5/16FOR
14	3700979	1	HOSE\HYD\3/4X19\1-1/16FJICX1-1/16FJIC BRANCH OF MIDDLE TEE'S PORT 3 SELECTOR VALVE TO OUT PORT OF TUB VALVE
15	3700980	1	HOSE\HYD\1/2X 50\3/4FJICX3/4FJIC CF PORT TUB FLOW CONTROL TO IN PORT OF TUB VALVE
16	3700984	1	HOSE\HYD\1/2X 137\3/4FJICX3/4FJIC PORT A TUB VALVE TO UPPER PORT TUB ORBIT MOTOR
17	3700984	1	HOSE\HYD\1/2X 137\3/4FJICX3/4FJIC PORT B TUB VALVE TO LOWER PORT TUB ORBIT MOTOR
18	3701058	1	HOSE\HYD\3/8X22\9/16FJICX9/16FJIC90 REAR STEM TUB PRESSURE GAUGE TO IN PORT TUB VALVE
	<b>NOT SHOWN</b>		
	4700777	3	CLMP\HOSE\1/2\PLATED
	O800550	28 in.	GAURD\POLY\SPIRAL;WRAP\HG-125

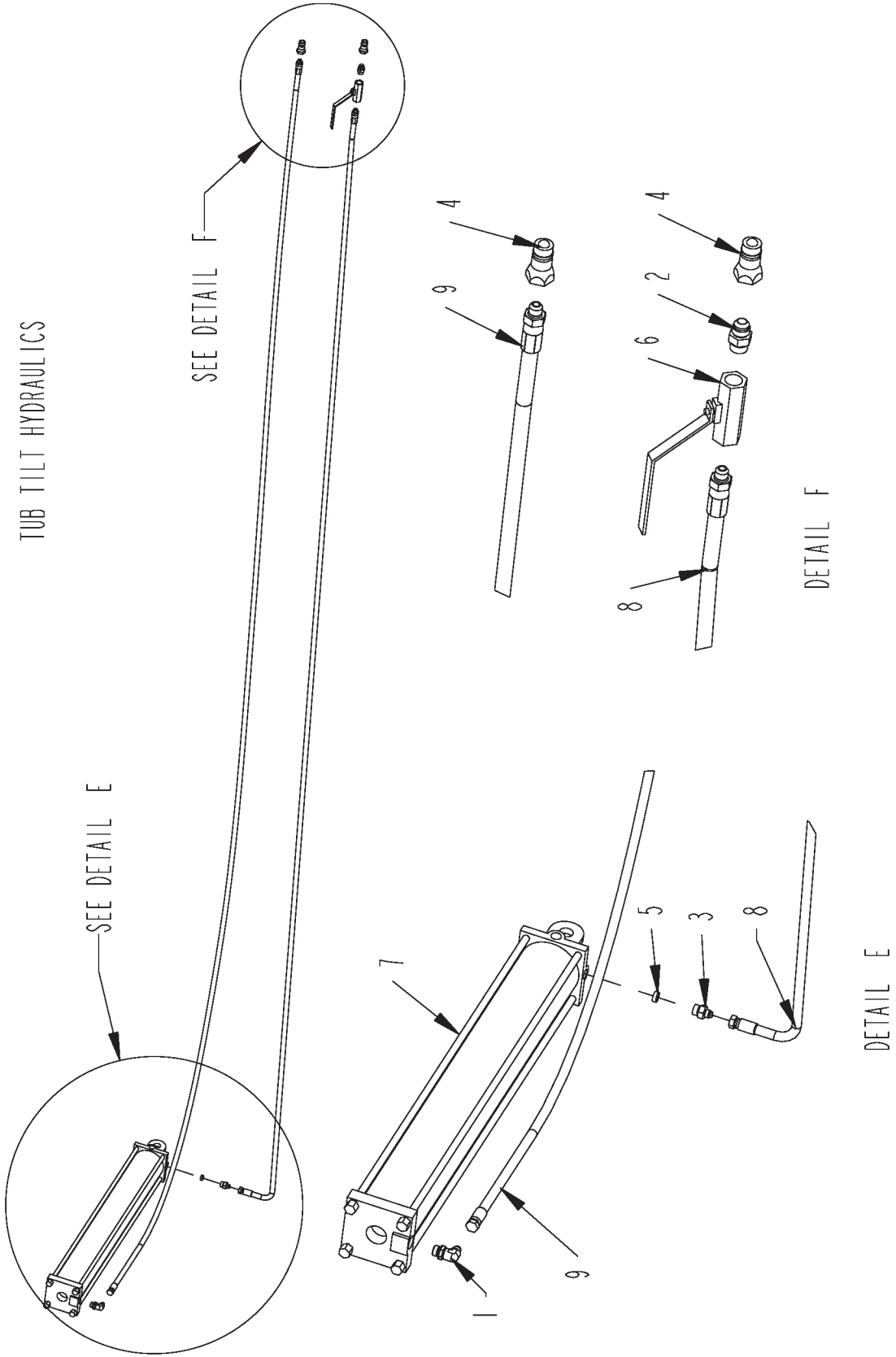
**CONVEYOR FOLD/UNFOLD & RAISE/LOWER VALVE  
HYDRAULICS**



**CONVEYOR FOLD/UNFOLD & RAISE/LOWER VALVE  
HYDRAULICS**

<b>ITEM</b>	<b>PART</b>	<b>QTY.</b>	<b>PART DESCRIPTION</b>
1	3800428	2	MNFLD\DBL;TEE\BLK\3\4FOR
2	3800453	4	FTG\3\4MORX9\16MJIC\90
3	3800530	6	FTG\3\4MORX9\16MJIC\ST
4	3800694	2	FTG\3\4FOR\QUICK;CPLR\MALE
5	3800903	1	FTG\HYD\3\4MORX3\4FOR\CHK
6	4000423	1	VLV\HYD\2BANK
7	7501387	6	CLMP\HOSE\CUSH\3\8\TWIN
8	3700985	1	HOSE\HYD\1\2X144\3\4MORX3\8FJICS TRACTOR TO CONVEYOR LIFT
9	3700985	1	HOSE\HYD\1\2X144\3\4MORX3\8FJICS TRACTOR TO CONVEYOR LIFT
10	3700988	1	HOSE\HYD\3\8X166\9\16FJICS PORT B1 CONVEYOR LIFT TO FRONT TOP FORWARD DIVIDER BLOCK
11	3700988	1	HOSE\HYD\3\8X166\9\16FJICS PORT A1 CONVEYOR LIFT TO REAR TOP FORWARD DIVIDER BLOCK
12	3700988	1	HOSE\HYD\3\8X166\9\16FJICS PORT A2 CONVEYOR FOLD TO FRONT TOP REAR DIVIDER BLOCK
13	3700988	1	HOSE\HYD\3\8X166\9\16FJICS PORT B2 CONVEYOR FOLD TO REAR TOP REAR DIVIDER BLOCK

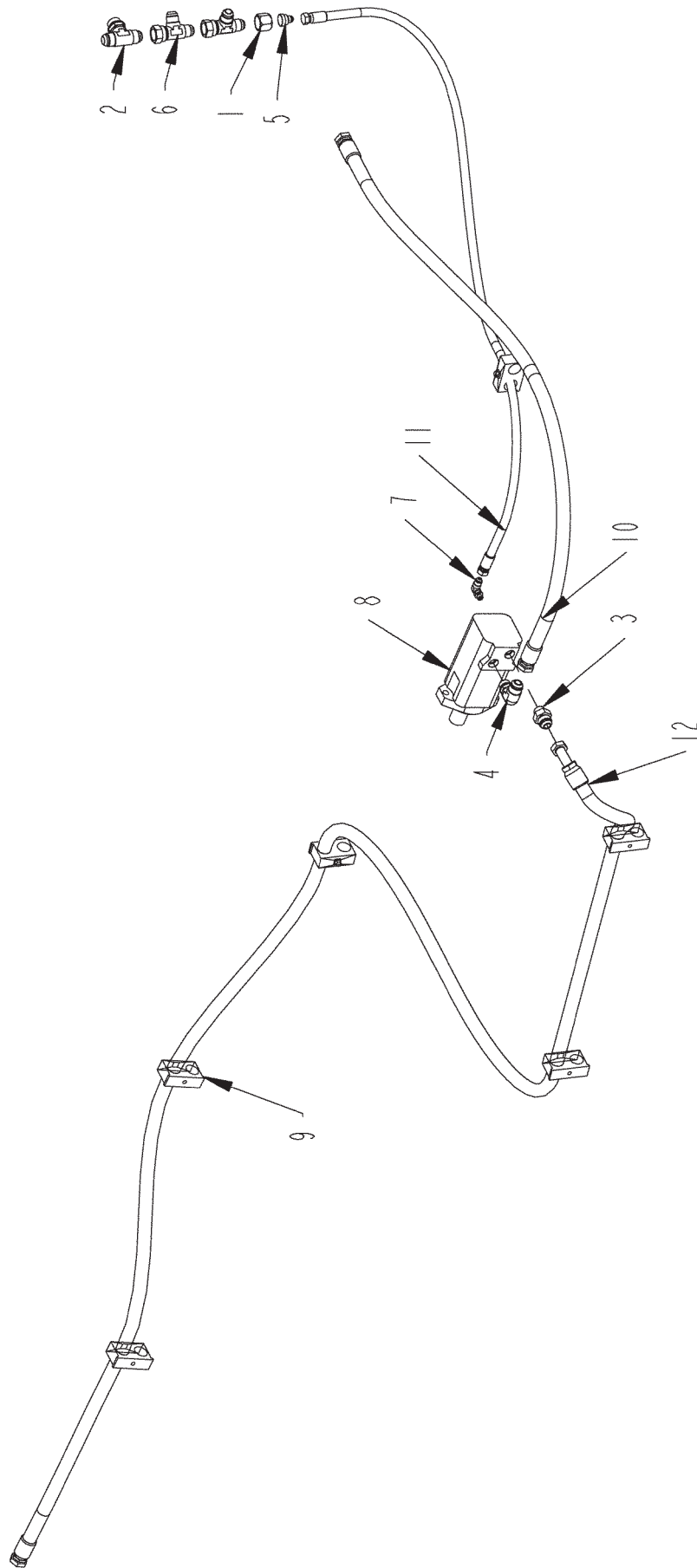
TUB TILT HYDRAULICS



**TUB TILT HYDRAULICS**

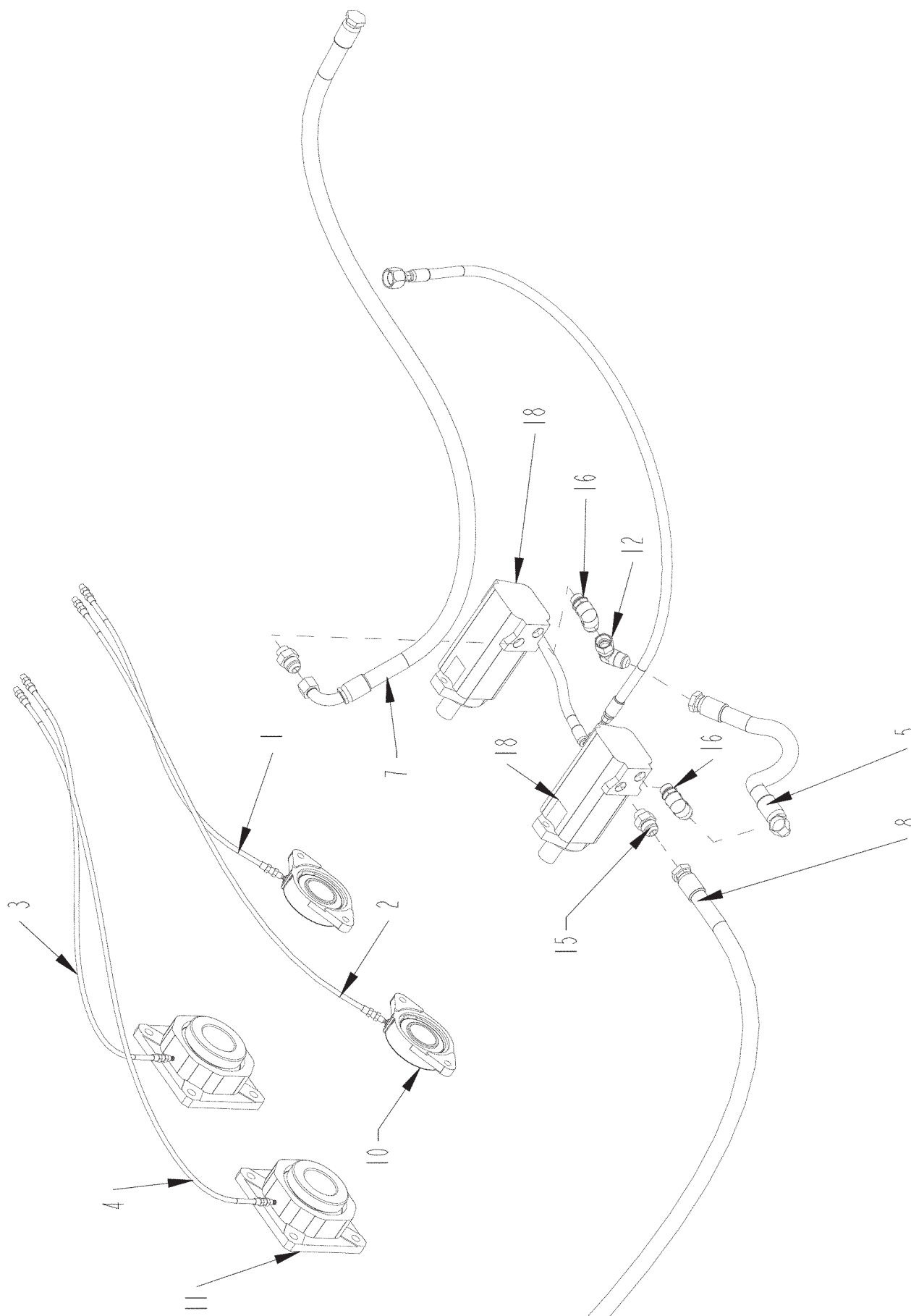
<b>ITEM</b>	<b>PART</b>	<b>QTY.</b>	<b>PART DESCRIPTION</b>
1	3800453	1	FTG\3/4MORX9/16MJIC\90
2	3800940	1	FTG\3/4MORX3/4MOR\ADPT
3	3800530	1	FTG\3/4MORX9/16MJIC\ST
4	3800694	2	FTG\3/4FOR\QUICK;CPLR\MALE
5	3800844	1	FTG\3/4MOR\ORIFICE\0.062"
6	4000443	1	VALVE\BALL\3/4FORX3/4FOR\7250PSI
	4000463		HANDLE\VALVE\BALL\AE2 (REPLACEMENT HANDLE FOR 4000443)
7	4100144	1	CYL\HYD\4X30\1-3/4 ROD\CLEVIS ENDS\O-RING PORTS
8	3700986	1	HOSE\HYD\3/8X171\3/4MORX9/16FJICS TRACTOR TO CAP END OF TUB TILT CYLINDER
9	3700987	1	HOSE\HYD\3/8X210\3/4MORX9/16FJICS TRACTOR TO ROD END TUB TILT CYLINDER

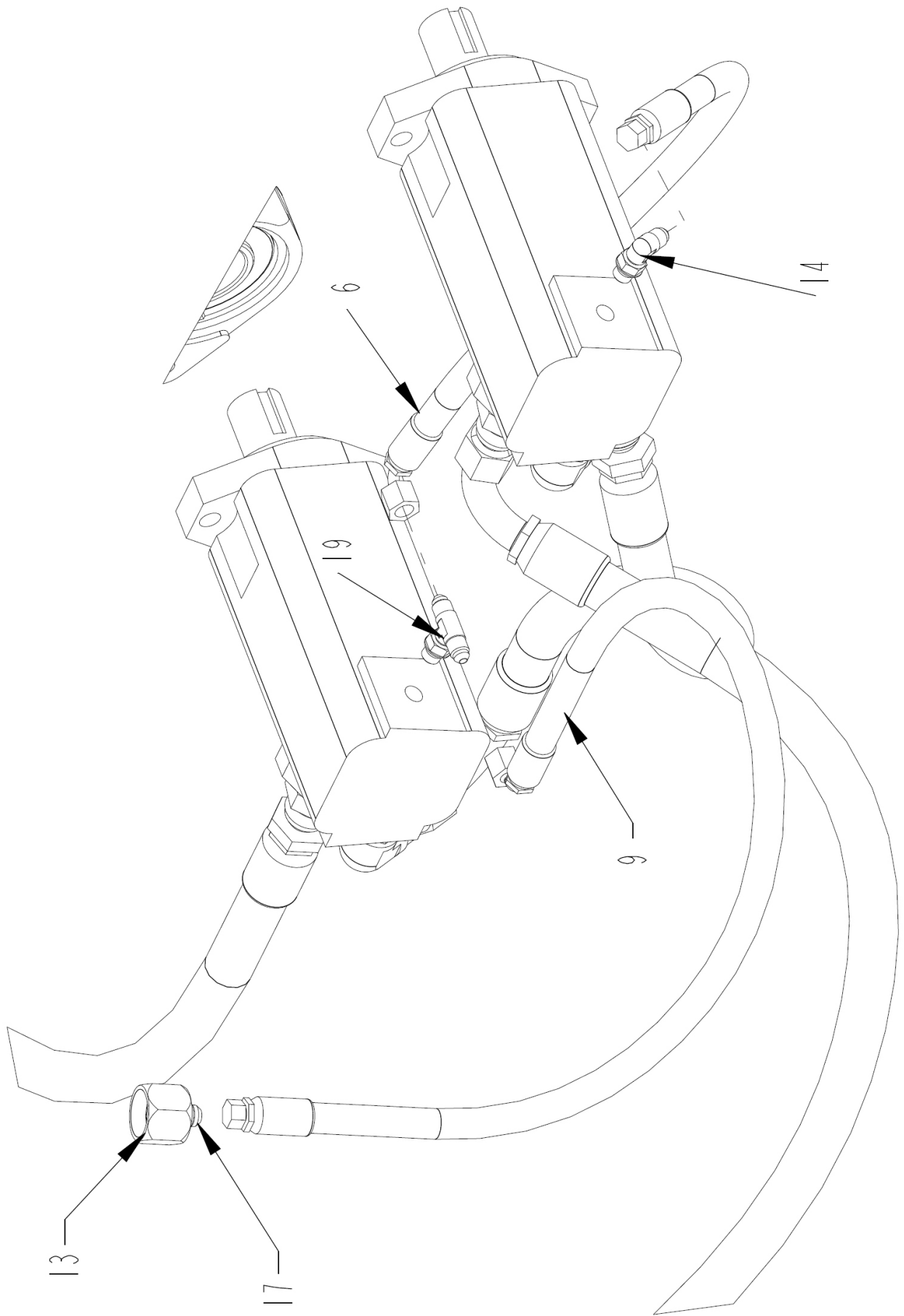
**BELLY AUGER ORBIT MOTOR HYDRAULICS (S.N. UP TO 1113040030)**



**BELLY AUGER ORBIT MOTOR HYDRAULICS (S.N. UP TO 1113040030)**

<b>ITEM</b>	<b>PART</b>	<b>QTY.</b>	<b>PART DESCRIPTION</b>
1	3800462	1	FTG\1-1/16NUTFJICS
2	3800481	1	FTG\1-1/16MJICX1-1/16MJICX1-1/16MOR\BR;TEE
3	3800527	1	FTG\7/8MORX1-1/16MJIC\ST
4	3800535	1	FTG\7/8MORX1-1/16MJIC\90
5	3800542	1	FTG\1-1/16FJICX9/16MJIC\ADPT
6	3800670	2	FTG\1-1/16FJICX1-1/16MJICX1-1/16MJIC\RUN;TEE
7	3800762	1	FTG\7/16MORX9/16MJIC\90
8	3900020	1	MTR\HYD\11.9\2000\SAE;A;
9	7501337	6	CLMP\HOSE\CUSH\3/8
10	3700969	1	HOSE\HYD\3/4X60\1-1/16FJICX1-1/16FJC PORT B AUGER ORBIT TO CF PORT FIXED FLOW CONTROL
11	3700971	1	HOSE\HYD\3/8X63\9/16FJICS CASE DRAIN ON AUGER ORBIT TO RUN OF RETURN TEE'S
12	3700967	1	HOSE\HYD\3/4X183\1-1/16FJX1-1/16FJC45DEG PORT A AUGER ORBIT TO IN PORT CONVEYOR FLOW CONTROL VALVE



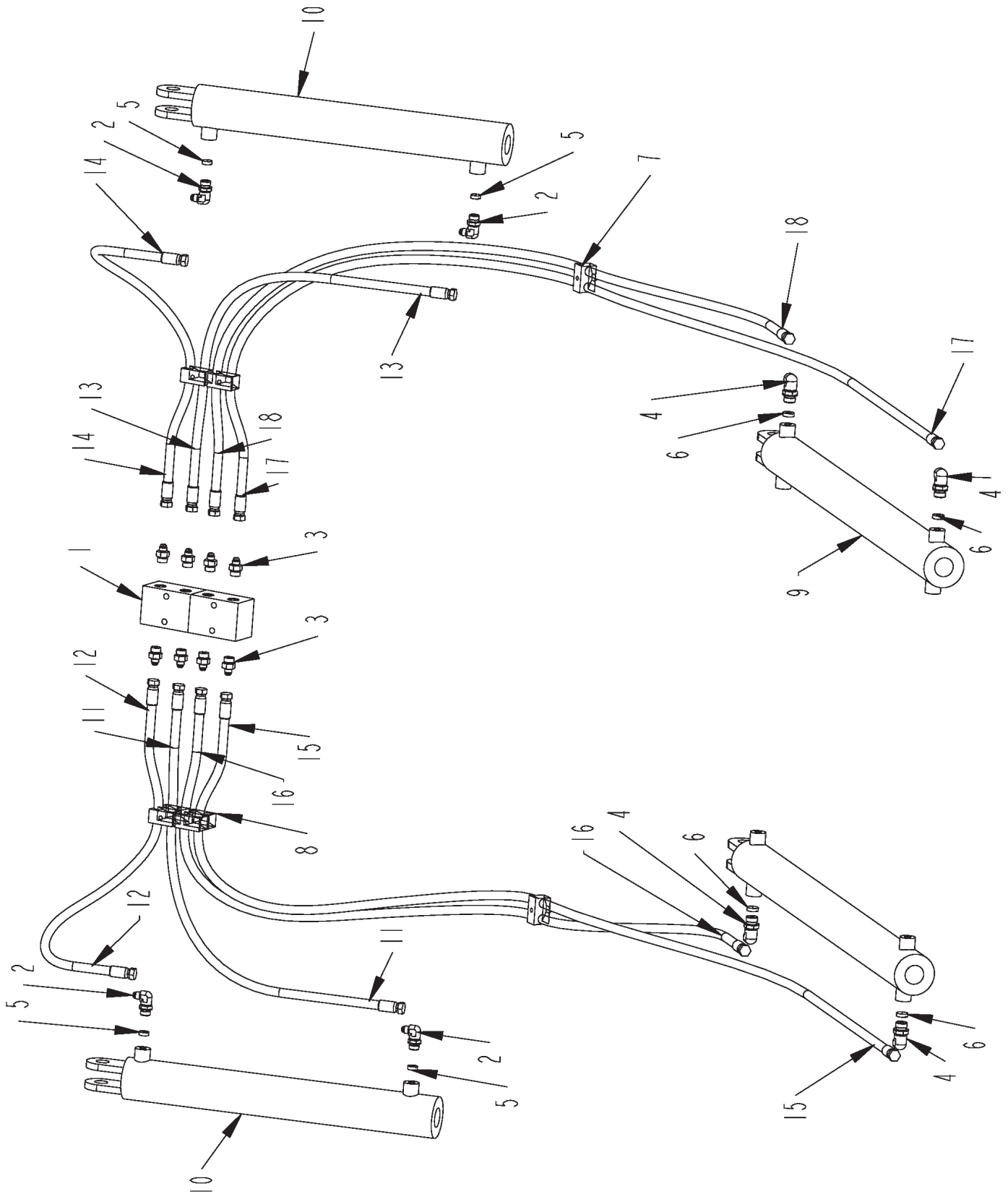




**BELLY AUGER HYDRAULICS & GREASE LINES (S.N. 1113040130 AND UP)**

<b>ITEM</b>	<b>PART</b>	<b>QTY.</b>	<b>PART DESCRIPTION</b>
1	3701485	1	HOSE\LUB\1/8X22.5\MPS-MPS
2	3701486	1	HOSE\LUB\1/8X35.25\MPS-MPS
3	3701487	1	HOSE\LUB\1/8X27.25\MPS-MPS
4	3701488	1	HOSE\LUB\1/8X43\MPS-MPS
5	3701483	1	HOSE\HYD\3/4X13.5\1-1/16FJC90X1-1/16FJC PORT B LEFT ORBIT MOTOR TO PORT B RIGHT ORBIT MOTOR
6	3701484	1	HOSE\HYD\3/8X21.25\7/16FJICX7/16FJIC\90 CASE DRAIN TEE RIGHT ORBIT TO CASE DRAIN LEFT ORBIT MOTOR
7	3701187	1	HOSE\HYD\3/4X35\1-1/16FJC90X1-1/16FJC PORT B AUGER MOTOR TO CF FIXED FLOW CONTROL
8	3701481	1	HOSE\HYD\3/4X203\1-1/16FJCX1-1/16FJC PORT A AUGER MOTOR TO IN PORT CINV. FLOW CONTROL
9	3701480	1	HOSE\HYD\1/4X57\7/16FJICX9/16FJIC CASE DRAIN ORBIT MOTOR TO RUN OF TEES
10	2000587	2	BRG\FLG\2"-BLT\SSCRW
11	2000588	2	BRG\FLG\2-1/2\4-BLT\D-LOCK
12	3800280	1	FTG\1-1/16MJICX1-1/16FJIC\90\SW
13	3800462	1	FTG\1-1/16NUTFJICS
14	3800472	1	FTG\7/16MORX7/16MJIC\90
15	3800527	2	FTG\7/8MORX1-1/16MJIC\ST
16	3800535	2	FTG\7/8MORX1-1/16MJIC\90
17	3800542	1	FTG\1-1/16FJICX9/16MJIC\ADPT
18	3900005	2	MTR\HYD\14.9\2000\SAE;A
19	3800988	1	FTG\7/16MJICX7/16MJICX7/16MOR\TEE

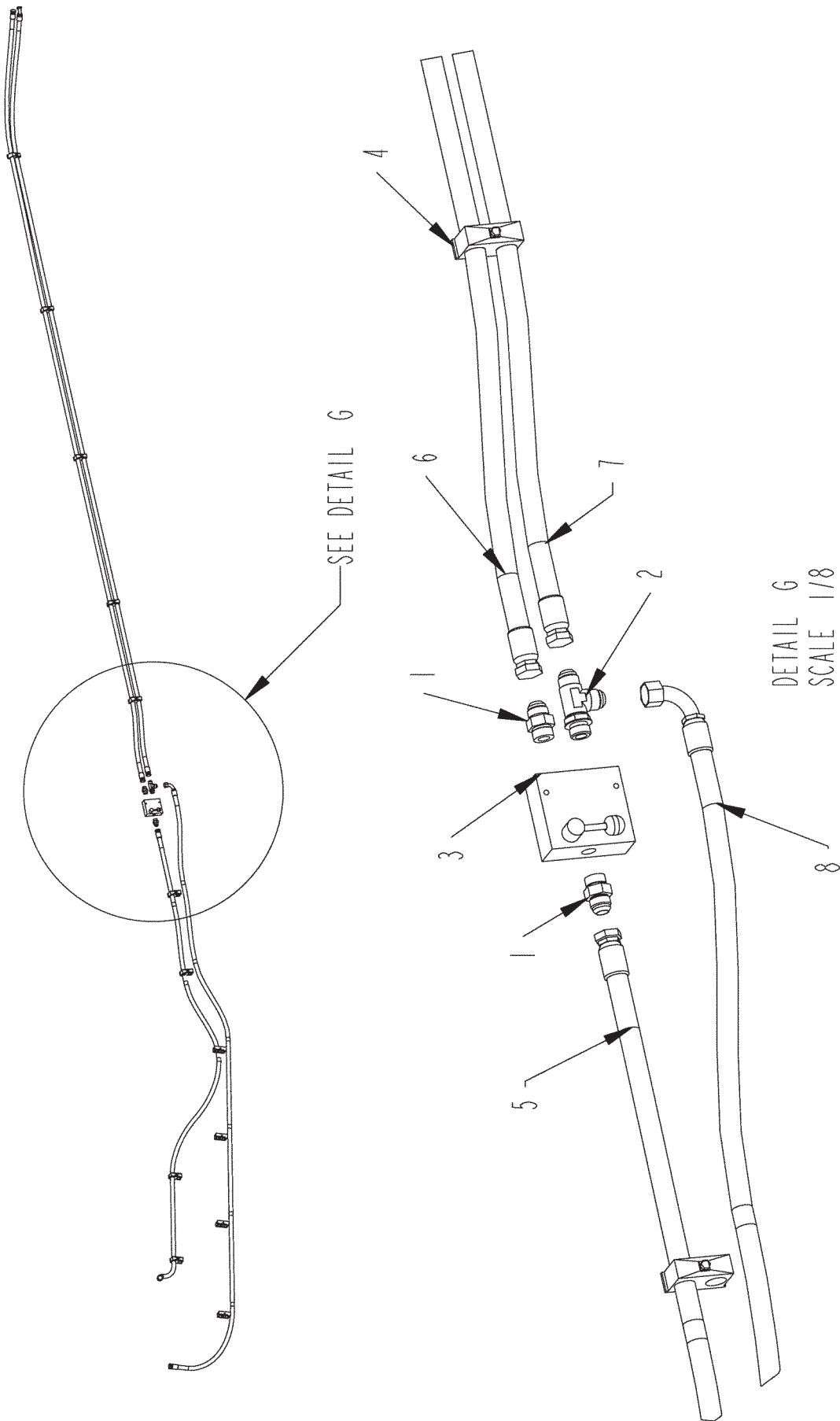
# CONVEYOR LIFT AND FOLD CYLINDER HYDRAULICS



**CONVEYOR LIFT AND FOLD CYLINDER HYDRAULICS**

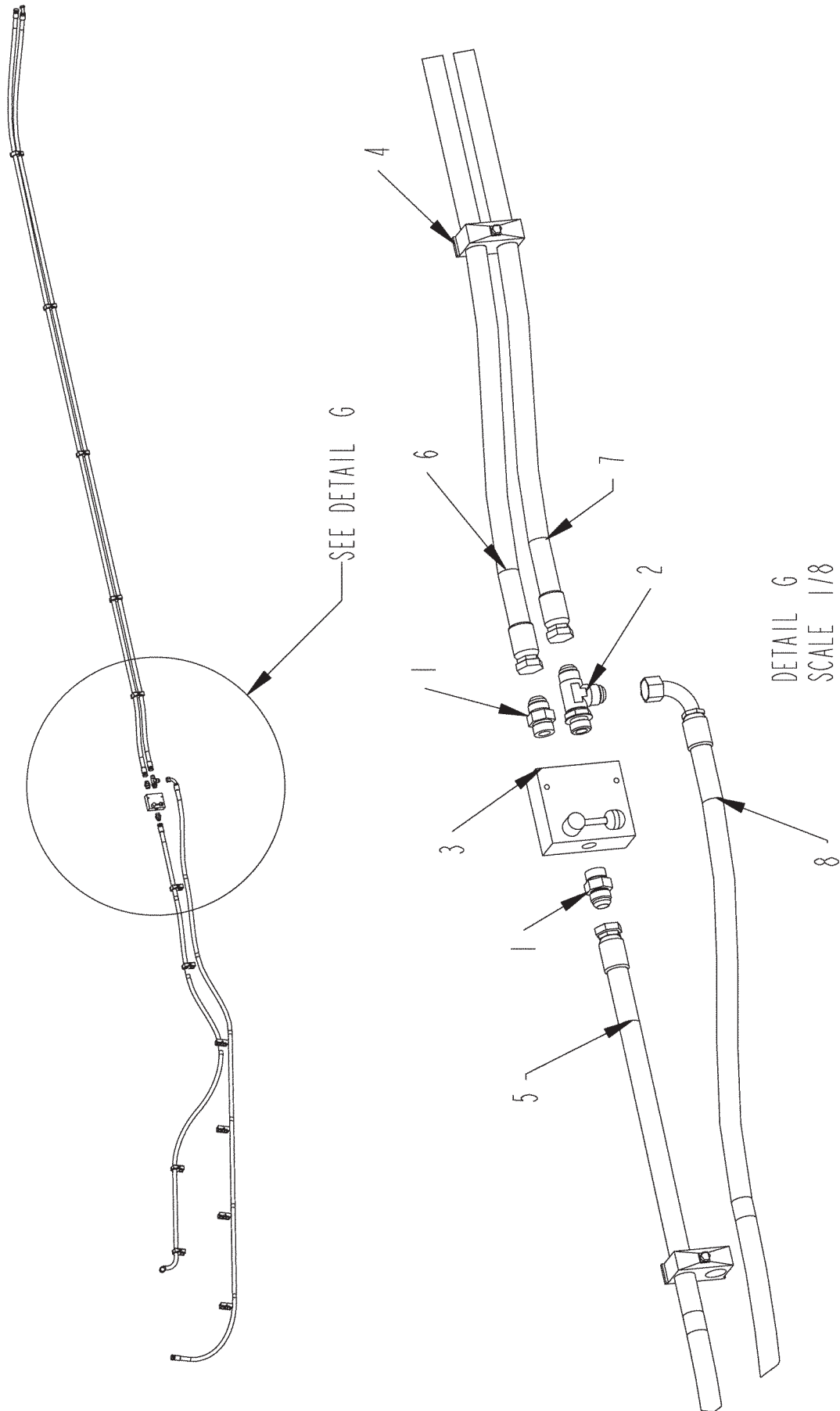
<b>ITEM</b>	<b>PART</b>	<b>QTY.</b>	<b>PART DESCRIPTION</b>
1	3800428	2	MNFLD\DBL;TEE\BLK\3/4FOR
2	3800453	4	FTG\3/4MORX9/16MJIC\90
3	3800530	8	FTG\3/4MORX9/16MJIC\ST
4	3800538	4	FTG\7/8MORX9/16MJIC\90
5	3800844	4	FTG\3/4MOR\ORIFICE\0.062"
6	3801016	4	FTG\7/8MOR\ORIFICE\0.052
7	7501336	4	CLMP\HOSE\CUSH\3/8
8	7501387	2	CLMP\HOSE\CUSH\3/8\TWIN
9	4100175	2	CYL\HYD\3X36\PARALLEL
10	4100261	2	CYL\HYD\3X20\1-1/2ROD -CANADIAN TOOL & DIE
10A	4100328		CYL\HYD\3X20\1-1/2ROD -RAM INDUSTRIES
11	3700989	1	HOSE\HYD\3/8X53\9/16FJICS ROD END LEFT LIFT CYLINDER TO REAR PORT FRONT DIVIDER BLOCK
12	3700913	1	HOSE\HYD\3/8X34\9/16FJICS CAP END LEFT LIFT CYLINDER TO FRONT PORT FRONT DIVIDER BLOCK
13	3700989	1	HOSE\HYD\3/8X53\9/16FJICS ROD END RIGHT LIFT CYLINDER TO REAR PORT FRONT DIVIDER BLOCK
14	3700913	1	HOSE\HYD\3/8X34\9/16FJICS CAP ENF RIGHT LIFT CYLINDER TO FRONT PORT FRONT DIVIDER BLOCK
15	3700990	1	HOSE\HYD\3/8X111\9/16FJICS ROD END LEFT FOLD CYLINDER TO REAR PORT REAR DIVIDER BLOCK
16	3700735	1	HOSE\HYD\3/8X73\9/16FJIC CAP END LEFT FOLD CYLINDER TO FRONT PORT REAR DIVIDER BLOCK
17	3700990	1	HOSE\HYD\3/8X111\9/16FJICS ROD END RIGHT FOLD CYLINDER TO REAR PORT REAR DIVIDER BLOCK
18	3700735	1	HOSE\HYD\3/8X73\9/16FJIC CAP END RIGHT FOLD CYLINDER TO FRONT PORT REAR DIVIDER BLOCK

CONVEYOR FLOW CONTROL VALVE HYDRAULICS (S.N. UP TO 1113040030)



**CONVEYOR FLOW CONTROL VALVE HYDRAULICS (S.N. UP TO 1113040030)**

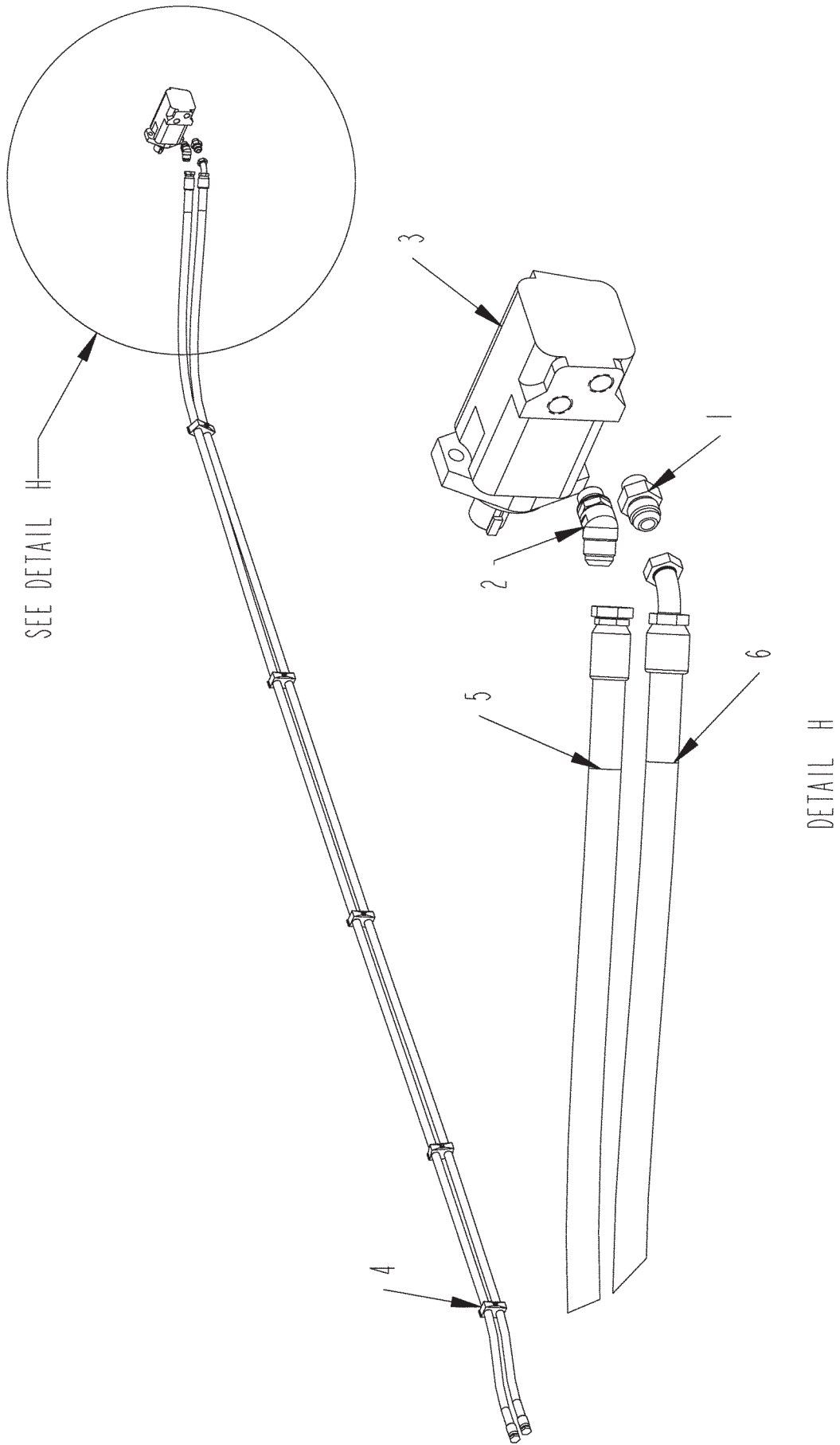
<b>ITEM</b>	<b>PART</b>	<b>QTY.</b>	<b>PART DESCRIPTION</b>
1	3800277	2	FTG\1-1/16MORX1-1/16MJIC\ST
2	3800463	1	FTG\1-1/16MORX1-1/16MJICX1-1/16MJIC\RUN;TEE
3	4000301	1	VALVE\FLW-CRTL\RD-112-30 <b>(FOR SN UP TO 1110010030)</b>
3A	4000482	1	VALVE\HYD\FLO;CNTRL\0-30\MAN <b>(FOR SN 1110010130 &amp; UP)</b>
4	7501337	13	CLMP\HOSE\CUSH\3/8
5	3700967	1	HOSE\HYD\3/4X183\1-1/16FJX1-1/16FJC45DEG PORT A AUGER ORBIT TO IN PORT CONVEYOR FLOW CONTROL VALVE
6	3700968	1	HOSE\HYD\3/4X238\1-1/16FJCX1-1/16FJC CF PORT CONVEYOR FLOW CONTROL TO PORT B CONVEYOR ORBIT
7	3700992	1	HOSE\HYD\3/4X236\1-1/16FJX1-1/16FJC45DEG PORT A CONVEYOR ORBIT TO EX PORT ON DISCHARGE CONVEYOR FLOW CONTROL VALVE
8	3700993	1	HOSE\HYD\3/4X202\1-1/16FJC90X1-1/16FJC EX PORT DISCHARGE CONVEYOR FLOW CONTROL TO PORT A CONVEYOR VALVE



**CONVEYOR FLOW CONTROL VALVE HYDRAULICS (S.N. 1113040130 AND UP)**

<b>ITEM</b>	<b>PART</b>	<b>QTY.</b>	<b>PART DESCRIPTION</b>
1	3800277	2	FTG\1-1/16MORX1-1/16MJIC\ST
2	3800463	1	FTG\1-1/16MORX1-1/16MJICX1-1/16MJIC\RUN;TEE
3	4000482	1	VALVE\HYD\FLO;CNTRL\0-30\MAN <b>(FOR SN 1110010130 &amp; UP)</b>
4	7501337	13	CLMP\HOSE\CUSH\3/8
5	3701481	1	HOSE\HYD\3/4X203\1-1/16FJCX1-1/16FJC PORT A AUGER ORBIT TO IN PORT CONVEYOR FLOW CONTROL VALVE
6	3700968	1	HOSE\HYD\3/4X238\1-1/16FJCX1-1/16FJC CF PORT CONVEYOR FLOW CONTROL TO PORT B CONVEYOR ORBIT
7	3700992	1	HOSE\HYD\3/4X236\1-1/16FJX1-1/16FJC45DEG PORT A CONVEYOR ORBIT TO EX PORT ON DISCHARGE CONVEYOR FLOW CONTROL VALVE
8	3700993	1	HOSE\HYD\3/4X202\1-1/16FJC90X1-1/16FJC EX PORT DISCHARGE CONVEYOR FLOW CONTROL TO PORT A CONVEYOR VALVE

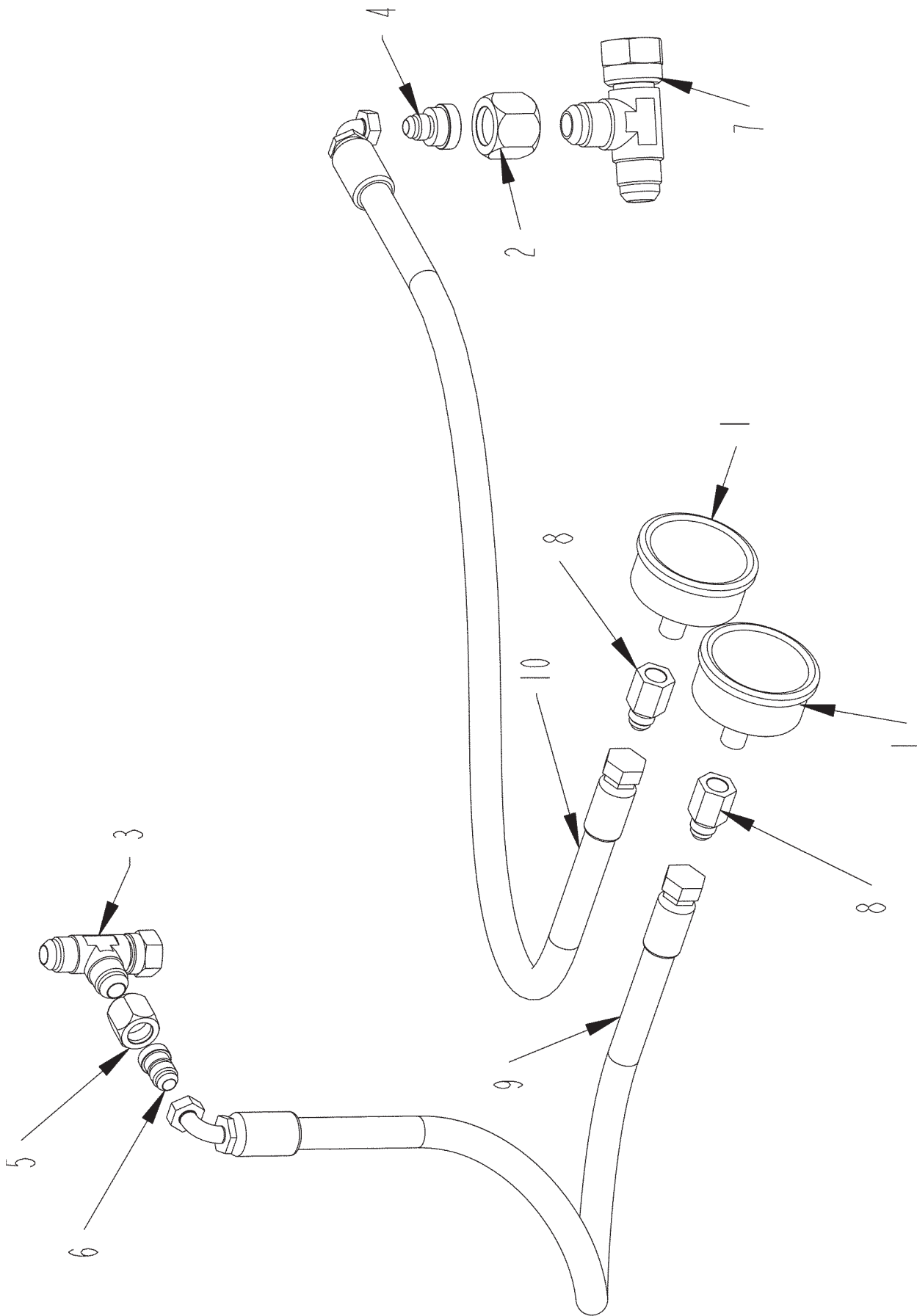
DISCHARGE CONVEYOR ORBIT MOTOR HYDRAULICS



**DISCHARGE CONVEYOR ORBIT MOTOR HYDRAULICS**

<b>ITEM</b>	<b>PART</b>	<b>QTY.</b>	<b>PART DESCRIPTION</b>
1	3800527	1	FTG\7/8MORX1-1/16MJIC\ST
2	3800669	1	FTG\MORXMJIC\45
3	3900014	1	MTR\HYD\9.6\2000\1-1/4SH
4	7501337	5	CLMP\HOSE\CUSH\3/8
5	3700968	1	HOSE\HYD\3/4X238\1-1/16FJCX1-1/16FJC CF PORT CONVEYOR FLOW CONTROL TO PORT B CONVEYOR ORBIT
6	3700992	1	HOSE\HYD\3/4X236\1-1/16FJX1-1/16FJC45DEG PORT A CONVEYOR ORBIT TO EX PORT ON DISCHARGE CONVEYOR FLOW CAONTROL VALVE

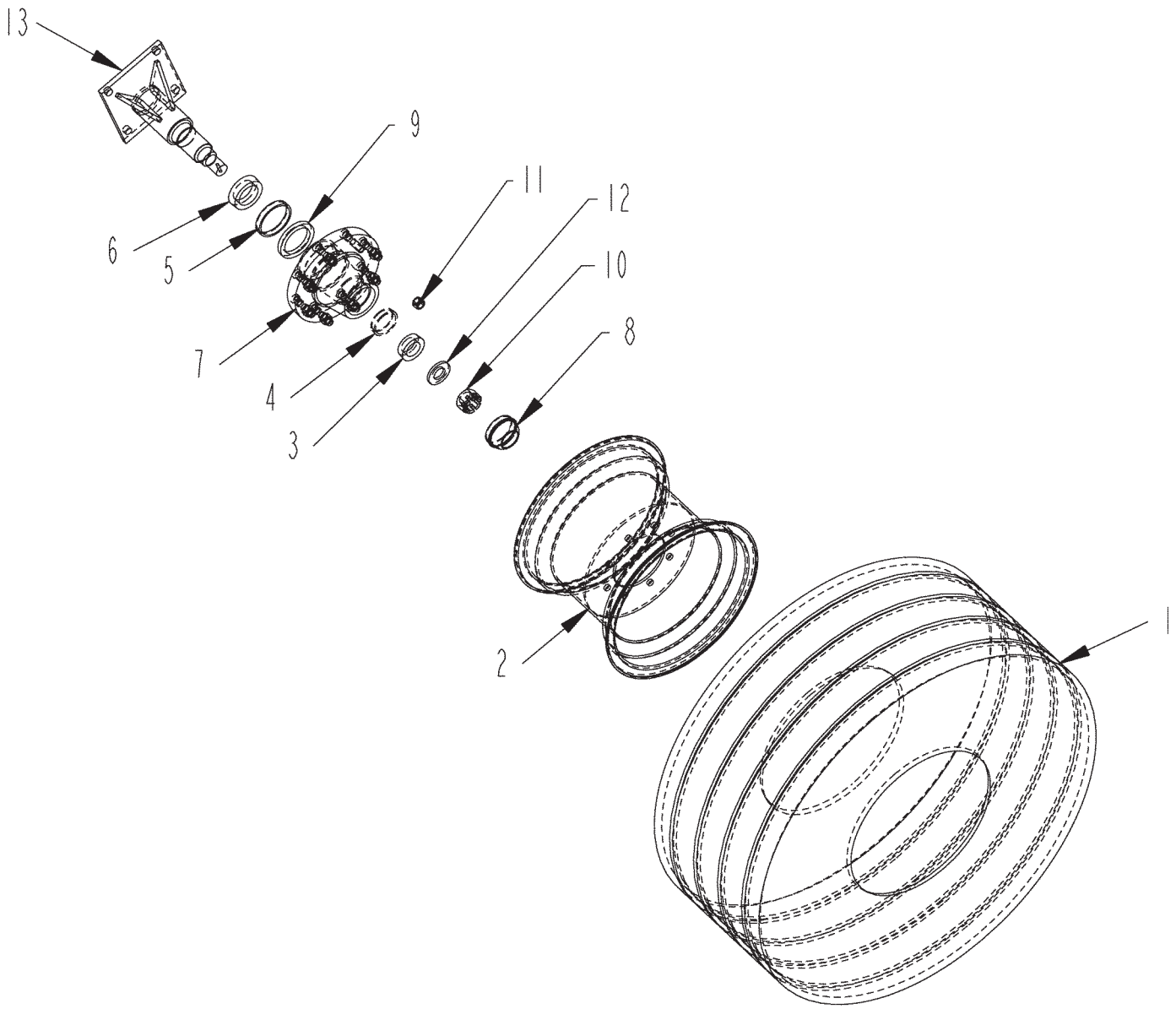
**PRESSURE GAUGES (S.N. 1110010130 AND UP)**



**PRESSURE GAUGES (S.N. 1110010130 AND UP)**

<b>ITEM</b>	<b>PART</b>	<b>QTY.</b>	<b>PART DESCRIPTION</b>
1	3800381	2	GAUGE\3000PSI\REAR STEM
2	3800462	1	FTG\1-1/16NUTFJICS
3	3800484	1	FTG\3/4FJICSX3/4MJICX3/4MJIC\RUN;TEE
4	3800542	1	FTG\1-1/16FJICX9/16MJIC\ADPT
5	3800549	1	FTG\3/4NUTFJIC
6	3800587	1	FTG\3/4FJICX9/16MJIC\ADPT
7	3800670	1	FTG\1-1/16FJICX1-1/16MJICX1-1/16MJIC\RUN;TEE
8	3800758	2	FTG\9/16MJICX1/4FP\ADPT
9	3701058	1	HOSE\HYD\3/8X22\9/16FJICX9/16FJC90 REAR STEM TUB PRESSURE GAUGE TO IN PORT TUB VALVE
10	3701059	1	HOSE\HYD\3/8X37\9/16FJICX9/16FJC90 REAR STEM CONVEYOR PRESSURE GAUGE TO IN PORT FIXED FLOW CONTROL

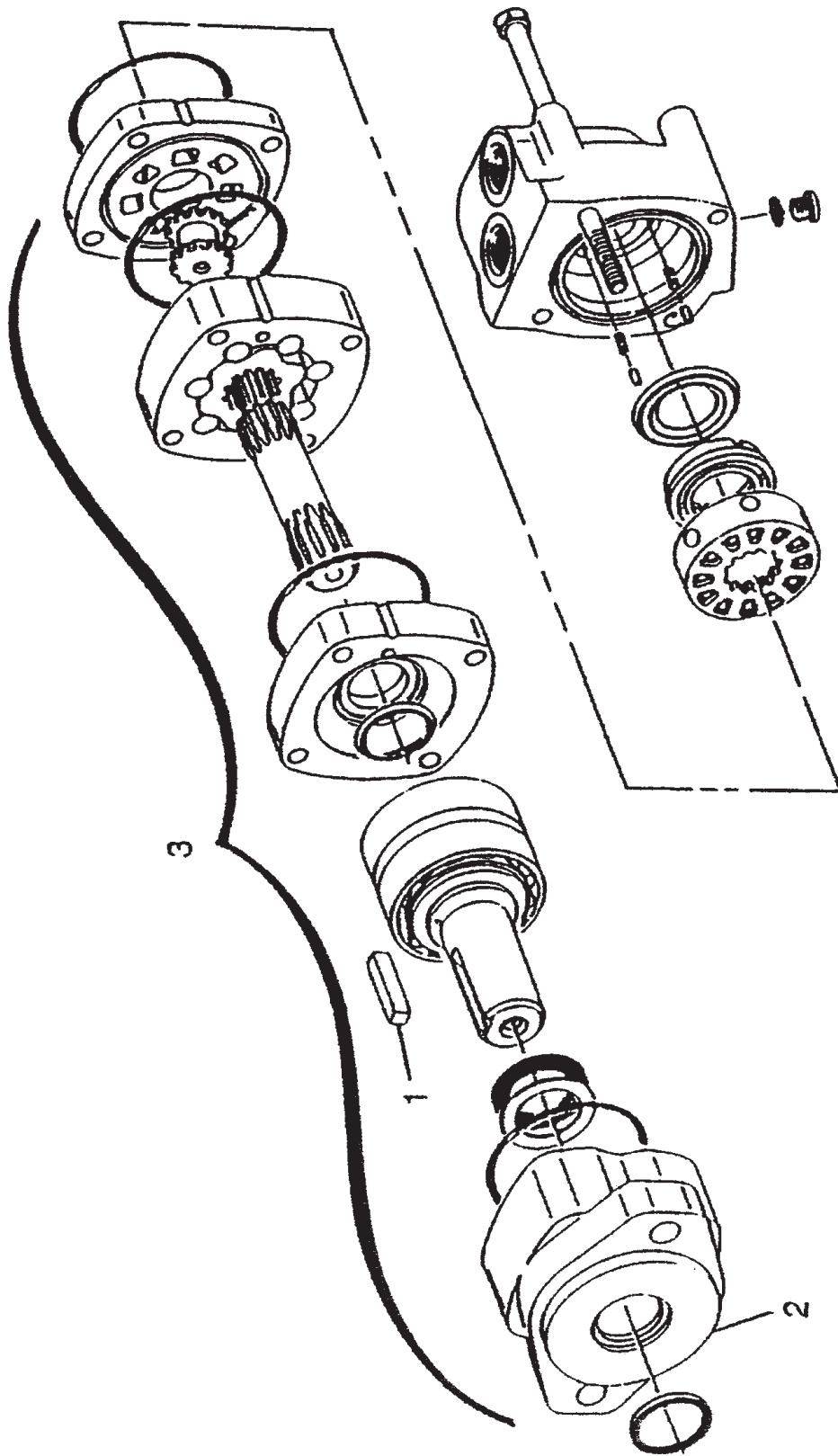
# WHEELS AND HUBS



**WHEELS AND HUBS**

<b>ITEM</b>	<b>PART</b>	<b>QTY.</b>	<b>PART DESCRIPTION</b>
1	2600053	1	TIRE\16.5LX16.1SL\14PLY
2	2600649	1	WHL\8-BOLT\16.1X14C\8K
3	2900125	1	HUB\H817\CONE\OUTER
4	2900126	1	HUB\H817\CUP\OUTER
5	2900127	1	CUP\INNER\WHL:HUB(48510
6	2900128	1	HUB\H817\CONE\INNER
7	2900140	1	HUB\8-BOLT\W\RACES\W\NUTS
8	2900130	1	CAP\DUST\H817
9	2900131	1	SEAL\GREASE\H817
10	4900053	1	NUT\CASTLE\1-1/4\NF
11	4900114	8	NUT\TAPER\WHEEL\5/8\NF
12	5000065	1	WASH\2.5OD\1.25ID\224
13	8101600	1	SPNDL\2800
	<b>2600861</b>		<b>WHL\ASSY\16.5SLX16.1\14PLY</b> (INCLUDES 1 & 2)
	<b>2900140</b>		<b>HUB\8-BOLT\COMPIH-817</b> (INCLUDES 3,4,5,6,7,8,9 & 11)

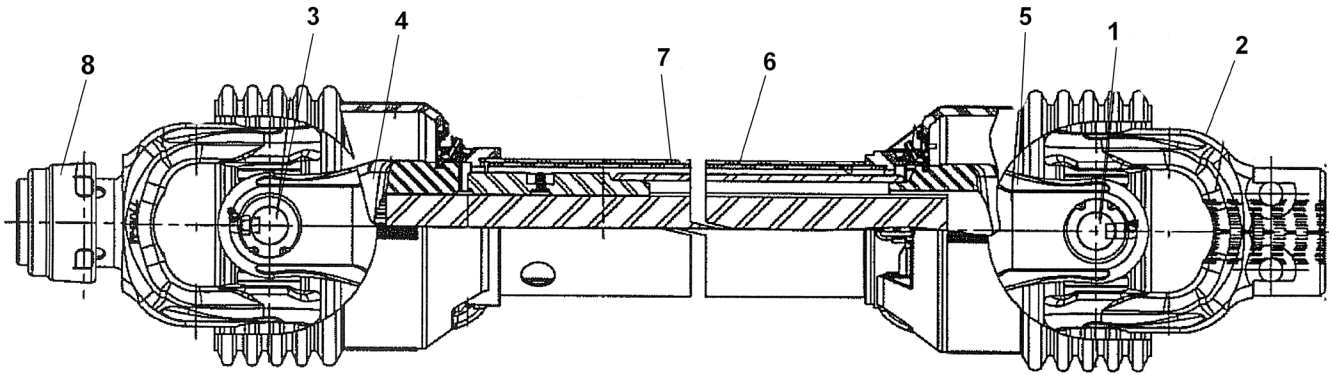
ORBIT MOTOR



**ORBIT MOTOR**

<b>ITEM</b>	<b>PART</b>	<b>QTY.</b>	<b>PART DESCRIPTION</b>
<b>3</b>	<b>3900014</b>	<b>1</b>	<b>MTR\HYD\9.6\2000\1-1/4SH</b>
1	6200004	1	KEY\SQ\5/16X1-1/2
2	3900011	1	MTG FLG(2000 SER)
4	7501005	1	KIT\SEAL\2000ORBIT
<b>3</b>	<b>3900020</b>	<b>1</b>	<b>MTR\HYD\11.9\2000\SAE;A;&gt;</b>
1	6200004	1	KEY\SQ\5/16X1-1/2
2	3900011	1	MTG FLG(2000 SER)
4	7501005	1	KIT\SEAL\2000ORBIT
<b>3</b>	<b>4200021</b>		<b>PUMP\EATON\25501-RSA\B MT</b>
	7501148		SEAL\KIT\PUMP\25500\EATON

**3600698 PTO ASSEMBLY**



**3600698 PTO\COMP\77E\20SP\1-3/4**

ITEM	PART NO.	DESCRIPTION
1	3600738	CROSS&BRG\77E\WSLR
2	3600740	YOKE\77E\1-3/4\20SPLN
3	3600741	YOKE\77E\1-3/4\LOCK\AUTO
4	3600742	YOKE&SHAFT\77E\3600698
5	3600743	YOKE&TUBE\77E\3600698
6	3600744	GUARD\PTO\1-3/4\77E\20SPLN\INNER
7	3600745	GUARD\PTO\1-3/4\77E\20SPLN\OUTER
8	3600775	LOCK\SAFETY;SLD\KIT\1-3/4\77E

**NOT SHOWN**

4800021 BOLT\HEX\5/8X3

4900005 NUT\HEX\5/8\NC

### 3600699 PTO ASSEMBLY

3600699 PTO\COMP\77E\21SP\1-3/8

FOR SN UP TO 1110005100

ITEM	PART NO.	DESCRIPTION
1	3600734	YOKE&SHAFT\77E\3600699
2	3600735	YOKE&TUBE\77E\3600699
3	3600736	GUARD\PTO\1-3/8\77E\21SPLN\INNER
4	3600737	GUARD\PTO\1-3/8\77E\21SPLN\OUTER
5	3600738	CROSS&BRG\77E\WSLR
6	3600739	YOKE\77E\1-3/8\LOCK\AUTO
7	3600740	YOKE\77E\1-3/4\20SPLN
8	3600775	LOCK\SAFTY;SLD\KIT\1-3/4\77E

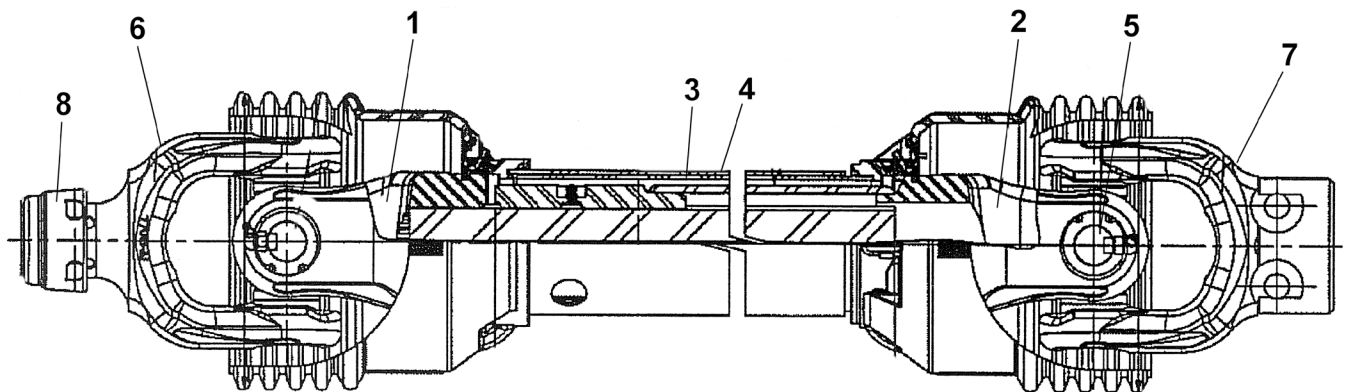
FOR SN 1110005101 & UP

ITEM	PART NO.	DESCRIPTION
1	3600734	YOKE&SHAFT\77E\3600699
2	3600735	YOKE&TUBE\77E\3600699
3	3600736	GUARD\PTO\1-3/8\77E\21SPLN\INNER
4	3600737	GUARD\PTO\1-3/8\77E\21SPLN\OUTER
5	3600738	CROSS&BRG\77E\WSLR
6	3600776	YOKE\77E\1-3/8\21PL\LOCK\AUTO
7	3600740	YOKE\77E\1-3/4\20SPLN
8	3600777	LOCK\SAFTY;SLD\KIT\1-3/8\77E

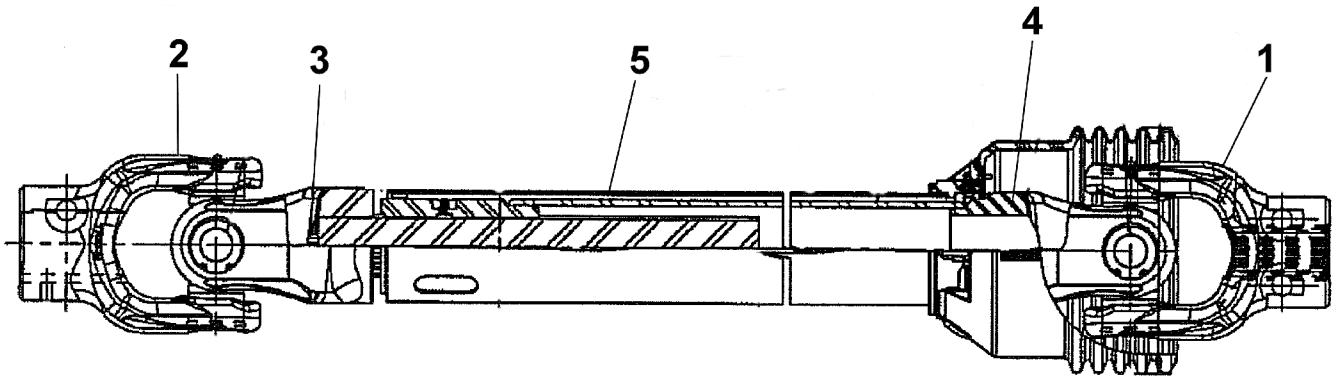
**NOTE:** 3600776 IS INTERCHANGEABLE WITH 3600739.  
 3600271 SAFETY LOCK REPAIR KIT USED WITH 3600739.  
 3600777 SAFETY LOCK REPAIR KIT USED WITH 3600776.

**NOT SHOWN**

- 4800021 BOLT\HEX\5/8X3
- 4900005 NUT\HEX\5/8\NC



**3600700 PTO ASSEMBLY**



**3600700 PTO\SCNDRY\77E**

ITEM	PART NO,	DESCRIPTION
1	3600740	YOKE\77E\1-3/4\20SPLN
2	3600746	YOKE\77E\2"
3	3600747	YOKE&SHAFT\77E\3600700
4	3600748	YOKE&TUBE\77E\3600700
5	3600749	GUARD\PTO\77E\SHFT\INT

## 3600768 PTO ASSEMBLY

3600768 PTO\COMP\77E\6SP\1-3/8

FOR SN UP TO 1110005100

ITEM	PART NO.	DESCRIPTION
1	3600734	YOKE&SHAFT\77E\3600699
2	3600735	YOKE&TUBE\77E\3600699
3	3600736	GUARD\PTO\1-3/8\77E\21SPLN\INNER
4	3600737	GUARD\PTO\1-3/8\77E\21SPLN\OUTER
5	3600738	CROSS&BRG\77E\WSLR
6	3600767	YOKE\77E\1-3/8\6-SPLINE\LOCK\AUTO
7	3600740	YOKE\77E\1-3/4\20SPLN
8	3600271	LOCK\SAFETY;SLID\KIT\1-3/8

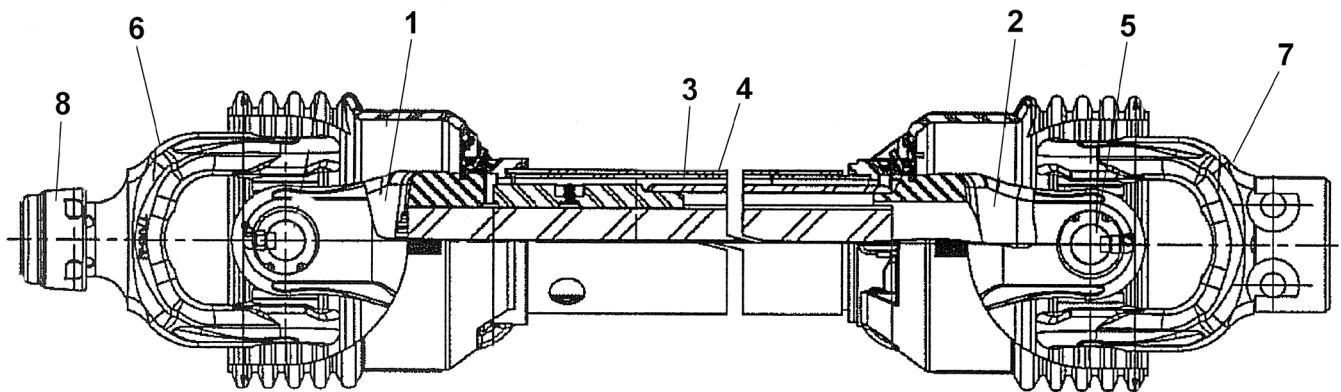
FOR SN 1110005101 & UP

ITEM	PART NO.	DESCRIPTION
1	3600734	YOKE&SHAFT\77E\3600699
2	3600735	YOKE&TUBE\77E\3600699
3	3600736	GUARD\PTO\1-3/8\77E\21SPLN\INNER
4	3600737	GUARD\PTO\1-3/8\77E\21SPLN\OUTER
5	3600738	CROSS&BRG\77E\WSLR
6	3600778	YOKE\77E\1-3/8\6SP\LOCK\AUTO\HD
7	3600740	YOKE\77E\1-3/4\20SPLN
8	3600777	LOCK\SAFETY;SLD\KIT\1-3/8\77E

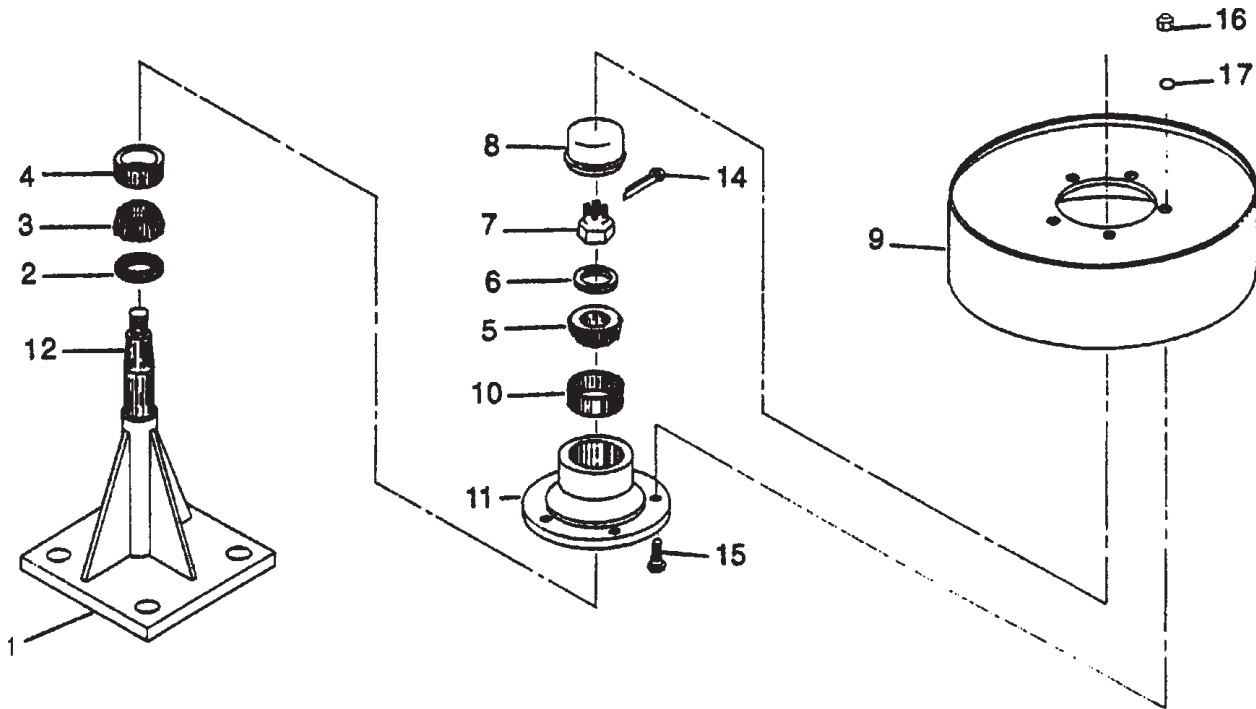
**NOTE:** 3600778 IS INTERCHANGEABLE WITH 3600767.

3600271 SAFETY LOCK REPAIR KIT USED WITH 3600767.

3600777 SAFETY LOCK REPAIR KIT USED WITH 3600778.



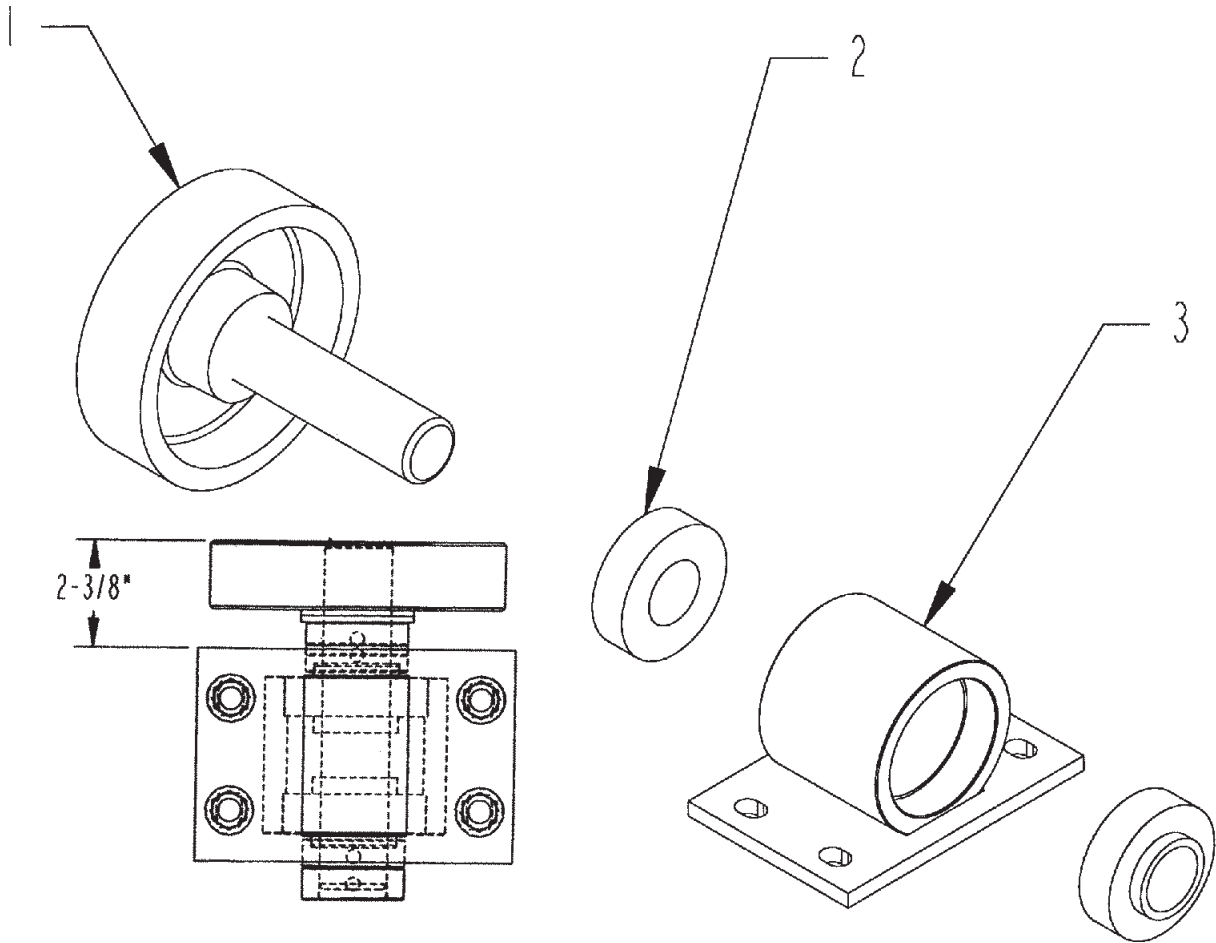
**PRESSURE ROLLER ASSEMBLY**



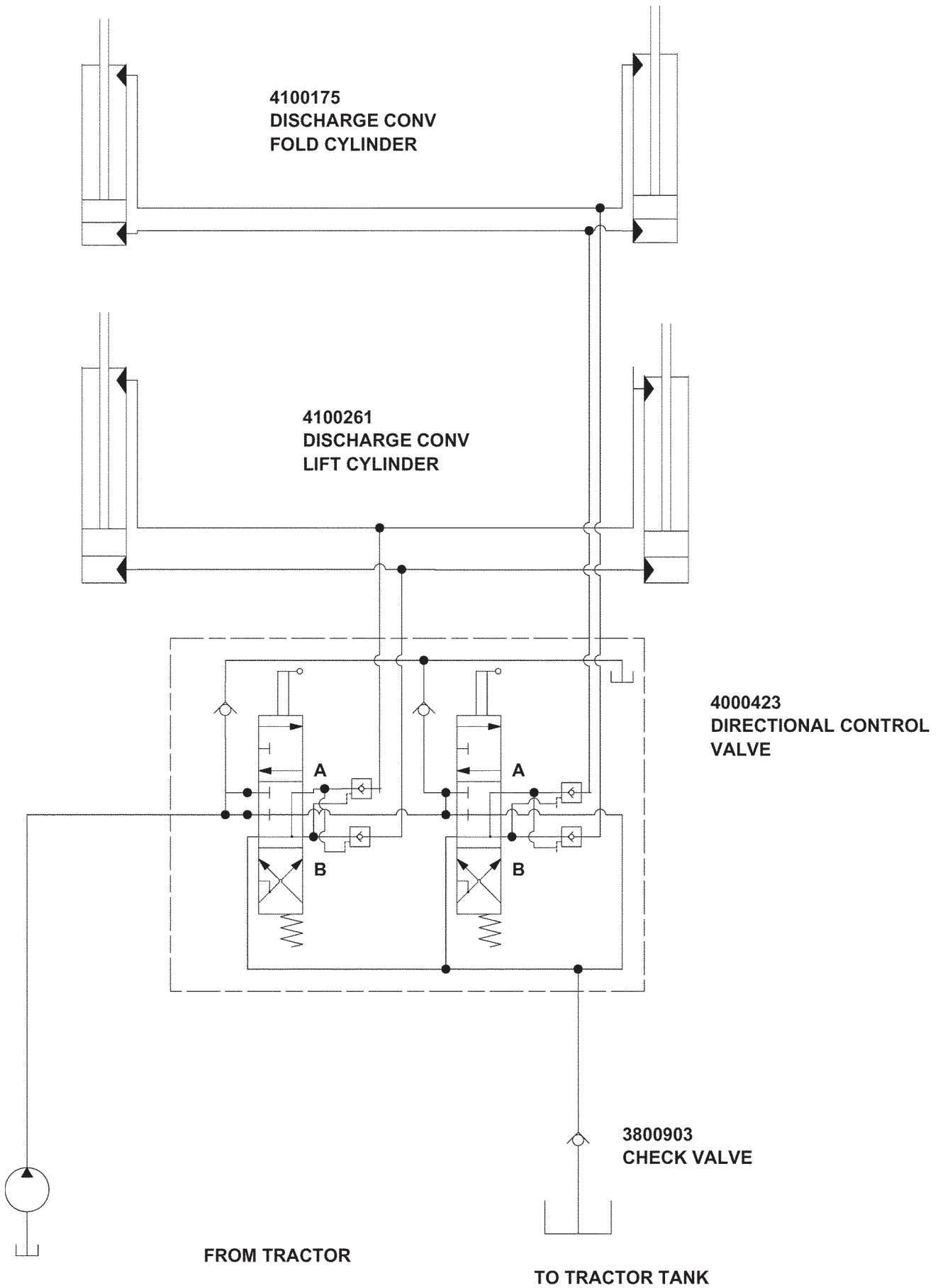
ITEM	PART	QTY.	PART DESCRIPTION
	4500247	1	PRESSURE ROLLER COMPLETE 10" SPINDLE
1	4501090	1	SINGLE STAND 10" SPINDLE
2	2900055	1	SEAL
3	2900018	1	INNER CONE
4	2900004	1	INNER CUP
5	2900061	1	OUTER CONE
6	5000094	1	5/8" WASHER\SPINDLE
7	4900112	1	NUT\SLOT\5/8\NF
8	2900064	1	DUST CAP
9	4500088	1	PRESSURE DRUM
10	2900056	1	OUTER CUP
11	NA	1	ORDER 2900057
12	3000025	1	PRESSURE ROLLER SPINDLE 10"
14	4800172	1	1/8" X 2" COTTER PIN
15	2900010	5	1/2" NF X 1-1/4" WHEEL STUD BOLT
16	4900094	5	1/2" NF WHEEL BOLT 13/16" O.D.
17	5000004	5	WASH\FLAT\1/2
	<b>2900057</b>		<b>HUB\5-BOLT\985\COMPLETE, W/BEARINGS,SEAL &amp; DUST CAP includes items 2,3,4,5,8,10,11,15,16</b>
<b>Not Shown</b>			
	4800949	4	BOLT\FLG\5/8X2\GR8\NC
	4900178	4	NUT\FLG\TPLCK\5/8\GR8\NC

## TUB ROLLER BEARING ASSEMBLY

ITEM	PART	QTY.	PART DESCRIPTION
1	1200013	1	RLLR\TUB\1-1/2\W/O FLANGE
2	2000584	2	BRG\CYL\1-1/2\DLOK
3	4702007	1	BRG\PB\RLLR\TUB\ASYW\BRGINSRT
	<b>4704069</b>		RLLR\TUB\ASSY\STEEL\CAST (INCLUDES #1, #2 & #3)
	<b>NOT SHOWN</b>		
	4800930	4	BOLT\FLG\SERR\1/2X2\NC
	4900100	4	NUT\FLG\TPLCK\1/2\NC

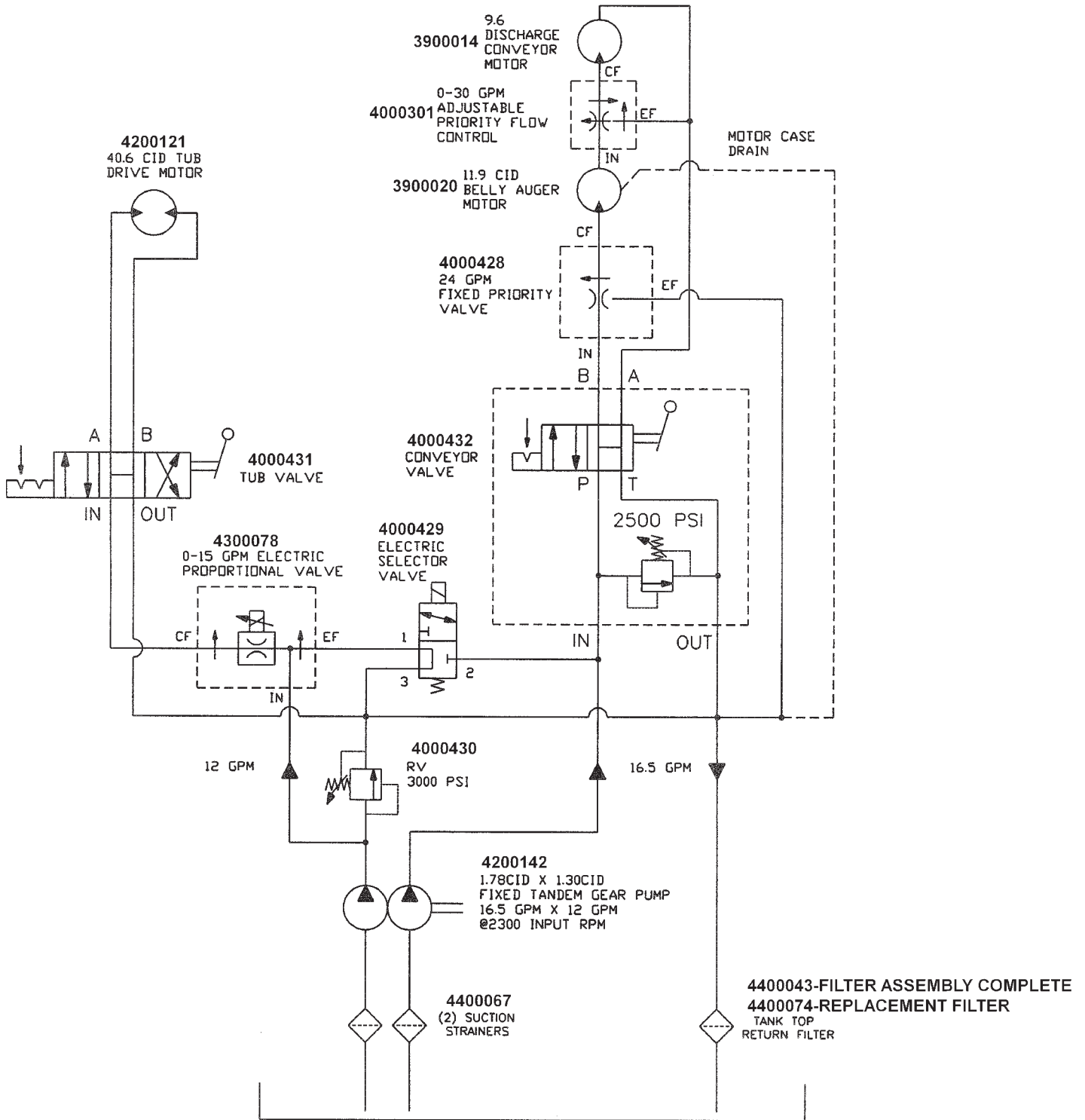


# TRACTOR POWERED FUNCTIONS HYDRAULIC SCHEMATIC

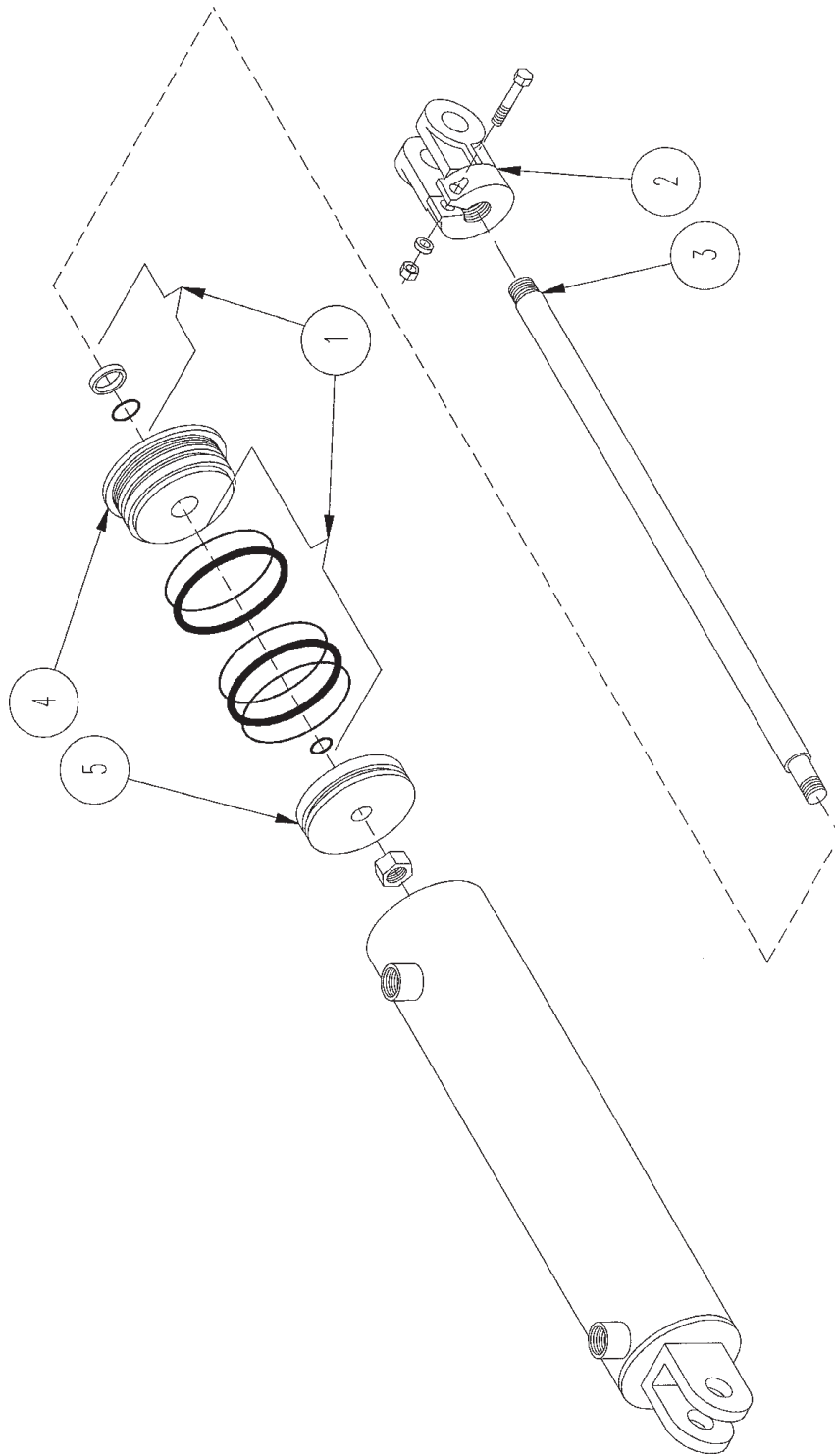


**TUB / CONVEYOR HYDRAULIC CIRCUIT**

MODEL 1130 TUB/CONVEYOR HYDRAULIC CIRCUIT



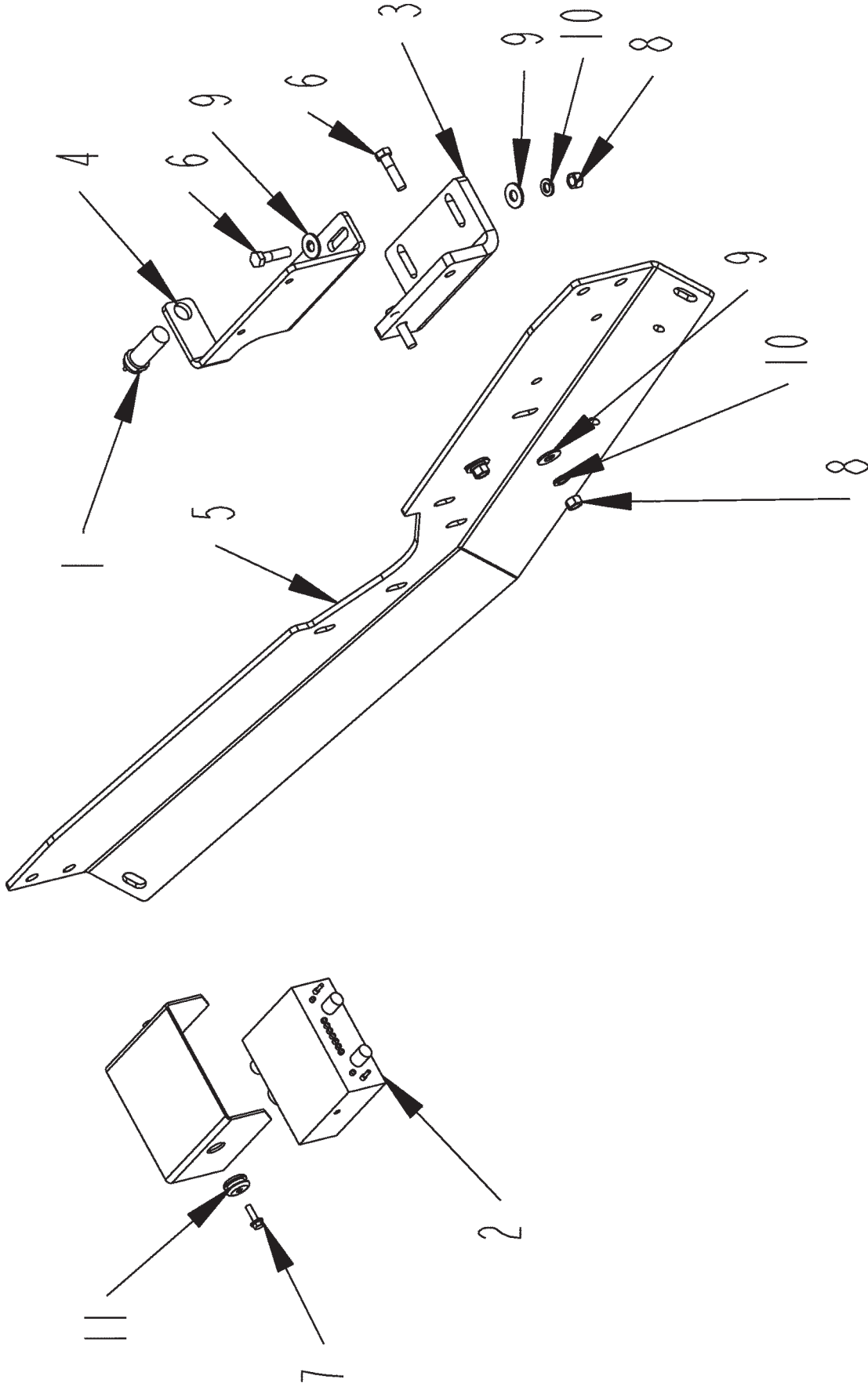
HYDRAULIC CYLINDER SEALS AND OTHER ITEMS



## HYDRAULIC CYLINDER SEALS AND OTHER ITEMS

ITEM	PART	QTY.	PART DESCRIPTION
	<b>4100144</b>		<b>CYL\HYD\4X30\1-3/4 ROD\CLEVIS ENDS\O-RING PORTS</b>
1	4100180	1	KIT\SEAL\CYL\HYD\4X30\1-3/4"ROD
2	4100181	1	YOKE\CYL\HYD\4X30\1-3/4\ROD
3	4100182	1	ROD\CYL\HYD\4X30\1-3/4\ROD
4	4100183	1	GLAND\CYL\HYD\4X30\1-3/4\ROD
5	4100184	1	PISTON\CYL\HYD\4X30\1-3/4\ROD
	4100219		
	<b>4100175</b>		<b>CYL\HYD\3X36\PARALLEL\CLEV\7/8FOR\R6-30HB2-36</b>
1	4100143	1	KIT\SEAL\CYL\HYD\3X24\>
2	4100132	1	YOKE ON 1.25" RAM ON 2.5"
3	4100174	1	ROD\CYL\HYD\1-1/2\3X36\>
4	4100102	1	GLAND\CYL\HYD\3"W\1-1/2 ROD
5	4100104	1	PISTON\CYL\HYD\3"RAM
	<b>4100261</b>		<b>CYL\HYD\3X20\1-1/2ROD\PAR</b>
1	4100289	1	KIT\SEAL\CYL\HYD\3X20
3	4100291	1	CYL\HYD\ROD\1-1/2\3X20
4	4100288	1	CYL\HYD\GLAND\3"\1-1/2"ROD\CTD
5	4100290	1	CYL\HYD\PISTON\3"\1-1/2"ROD\CTD
	<b>4100328</b>		<b>CYL\HYD\3X20\1-1/2ROD -RAM INDUSTRIES</b>
1	4100143	1	SEAL KIT FOR 4100328

# ELECTRONIC GOVERNOR ASSEMBLY



**ELECTRONIC GOVERNOR ASSEMBLY**

<b>ITEM</b>	<b>PART</b>	<b>QTY.</b>	<b>PART DESCRIPTION</b>
1	4300088	1	SENSOR\MAG\W\HARDWARE
2	4300034	1	CONTROL BOX
3	4502405	1	PL\MNT\PKP\SPD
4	4502421	1	BRCKT\MNT\PCKP\SPD
5	4502439	1	ANGL\CRSS\FRM\MID
6	4800034	4	BOLT\HEX\3/8X1-1/2
7	4800301	2	SCR\FLNG\SERR\1/4X3/4
8	4900002	4	NUT\HEX\3/8\NC
9	5000001	6	WASH\FLAT\3/8
10	5000019	4	WASH\LOCK\3/8
11	7500124	2	GRMT\RBBR\1X9/32IDX3/16T

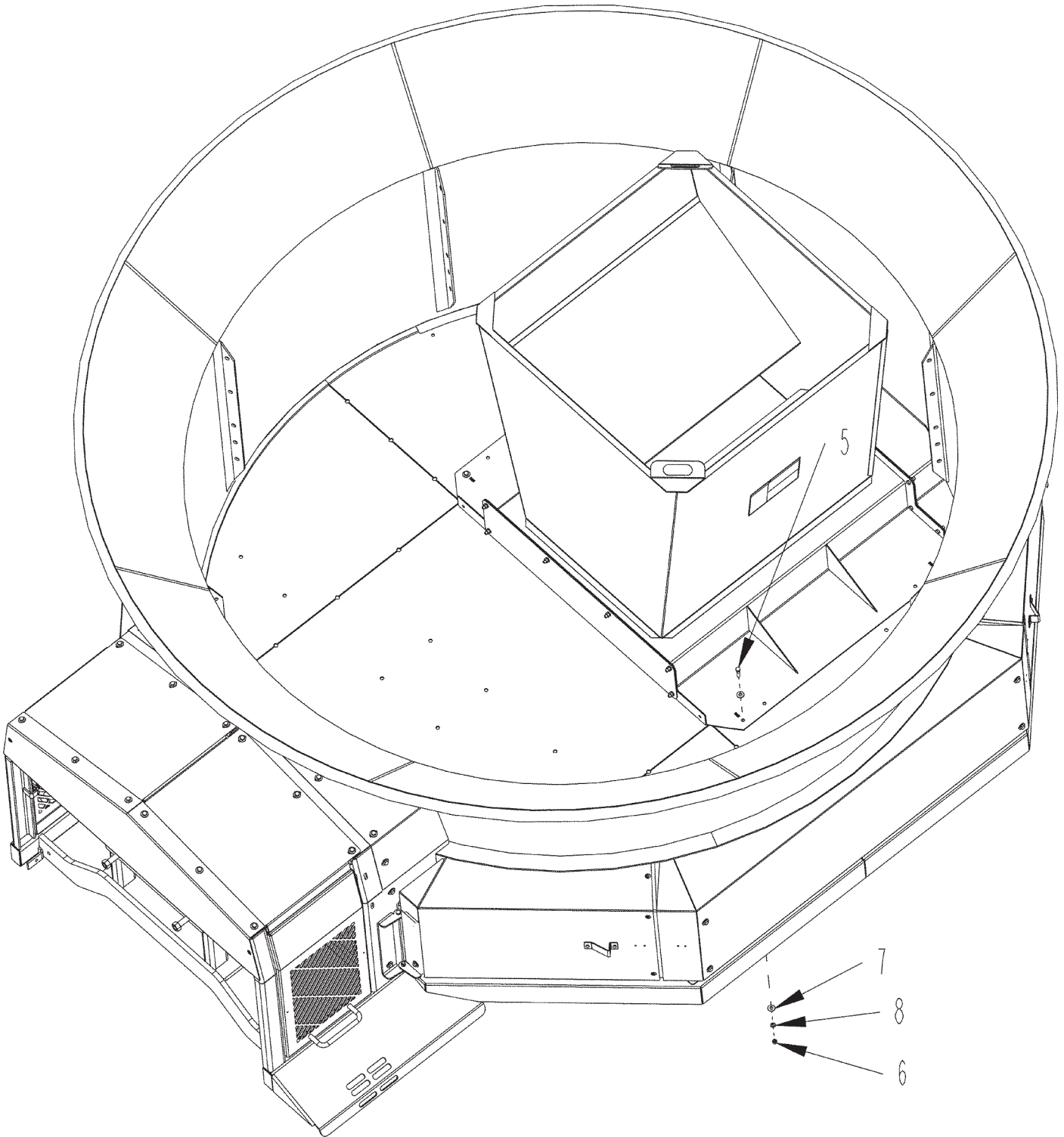
**NOT SHOWN**

5700845 HARN\MAIN\1130

**FOR ELECTRIC MOTORS**

4300062 CNTRL\GOV\ELEC\MTR\ELEC\

**GRAIN HOPPER #1 (OPTION)**



## GRAIN HOPPER #1 (OPTION)

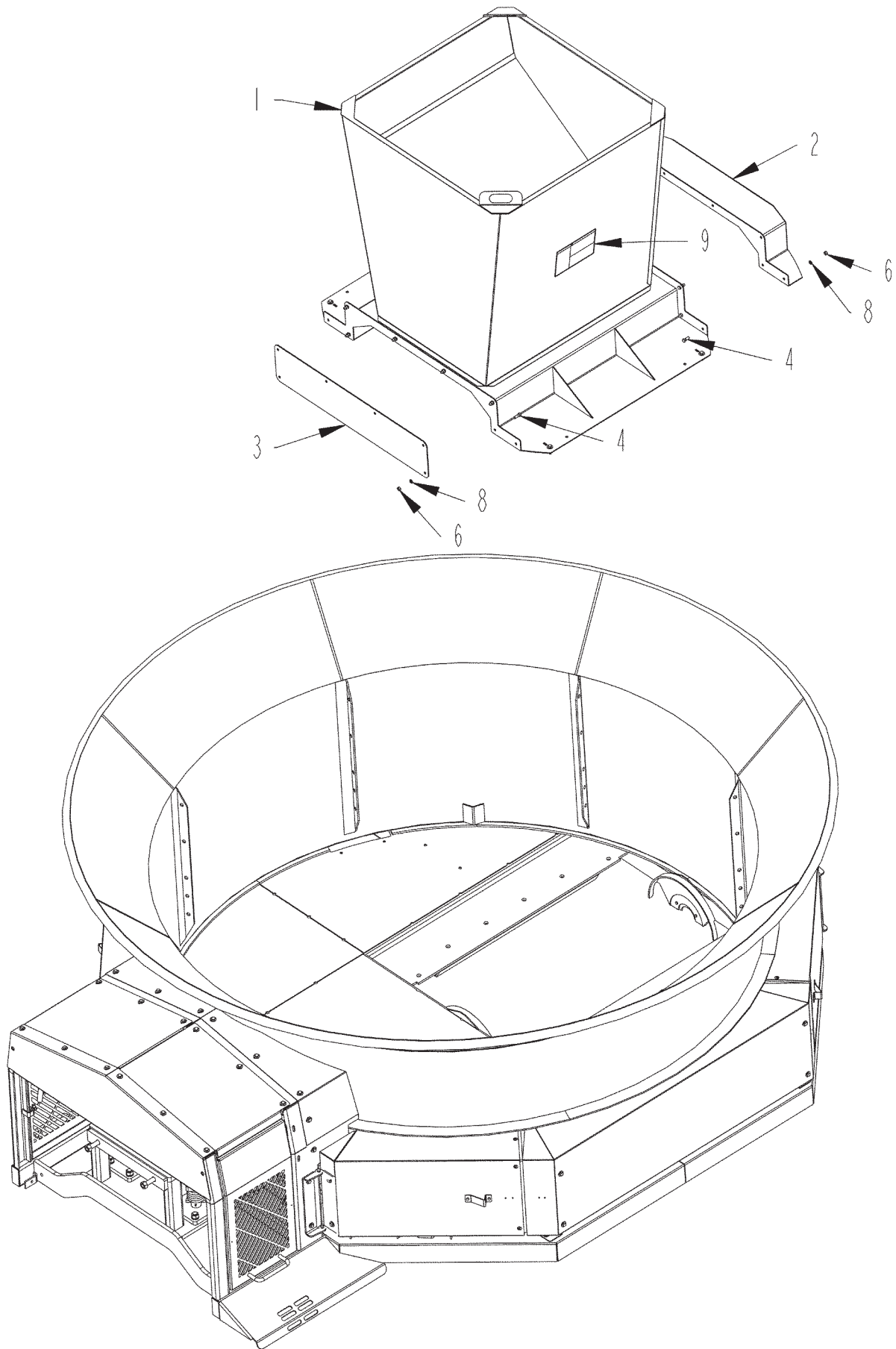
ITEM	PART	QTY.	PART DESCRIPTION
	4501347		HPPR\GRAIN\ASSY\COMPLETE
1	4501335	1	HPPR\GRAIN
2	4501340	1	CVR\RTR\HPPR\GRAIN
3	4501341	1	CVR\END\HPPR\GRAIN
4	4800003	14	BOLT\HEX\3/8X1
5	4800034	4	BOLT\HEX\3/8X1-1/2
6	4900002	18	NUT\HEX\3/8\NC
7	5000001	8	WASH\FLAT\3/8
8	5000019	18	WASH\LOCK\3/8
9	6500452	2	DECAL\INFO\GRAIN;HPPR

### Grain Hopper Option Installation:

1. Orient tub so that two interior tub angles are centered in front of cylinder box.
2. Bolt front(Item 2) and rear(Item 3) covers to grain hopper with hardware.  
Check to see that hopper baffle orientation is correct.
3. Place rounded end of hopper tight against the tub seal ring.
4. Check to see the hopper is centered side to side over rotor.
5. Drill four 7/16" holes through tub floor using hopper as guide.
6. Secure hopper to the floor with provided 3/8" hardware.

**IMPORTANT! DO NOT ROTATE TUB WITH HOPPER INSTALLED**

**GRAIN HOPPER #2 (OPTION)**



## GRAIN HOPPER #2 (OPTION)

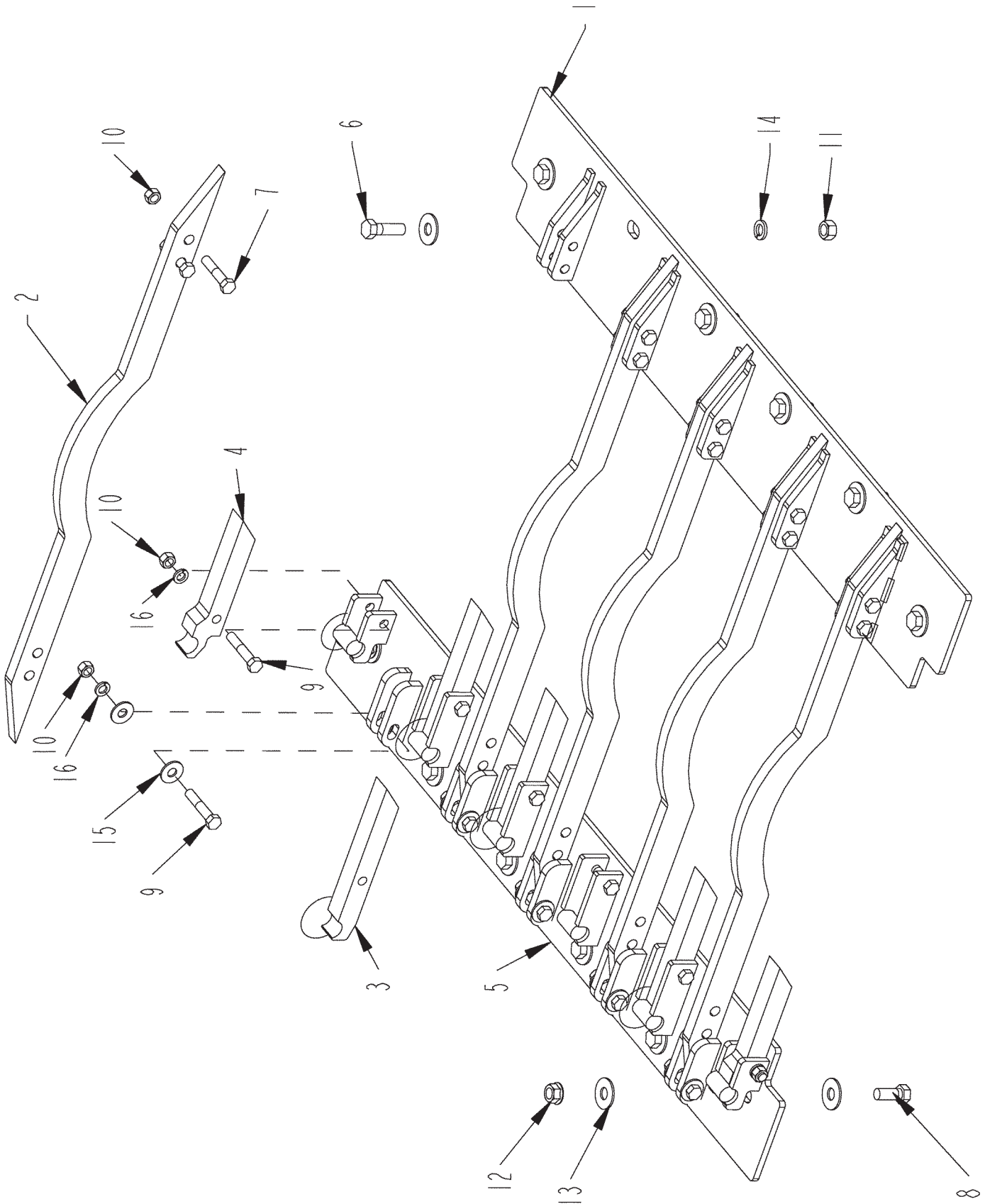
ITEM	PART	QTY.	PART DESCRIPTION
	4501347		HPPR\GRAIN\ASSY\COMPLETE
1	4501335	1	HPPR\GRAIN
2	4501340	1	CVR\RTR\HPPR\GRAIN
3	4501341	1	CVR\END\HPPR\GRAIN
4	4800003	14	BOLT\HEX\3/8X1
5	4800034	4	BOLT\HEX\3/8X1-1/2
6	4900002	18	NUT\HEX\3/8\NC
7	5000001	8	WASH\FLAT\3/8
8	5000019	18	WASH\LOCK\3/8
9	6500452	2	DECAL\INFO\GRAIN;HPPR

### Grain Hopper Option Installation:

1. Orient tub so that two interior tub angles are centered in front of cylinder box.
2. Bolt front(Item 2) and rear(Item 3) covers to grain hopper with hardware.  
Check to see that hopper baffle orientation is correct.
3. Place rounded end of hopper tight against the tub seal ring.
4. Check to see the hopper is centered side to side over rotor.
5. Drill four 7/16" holes through tub floor using hopper as guide.
6. Secure hopper to the floor with provided 3/8" hardware.

**IMPORTANT! DO NOT ROTATE TUB WITH HOPPER INSTALLED**

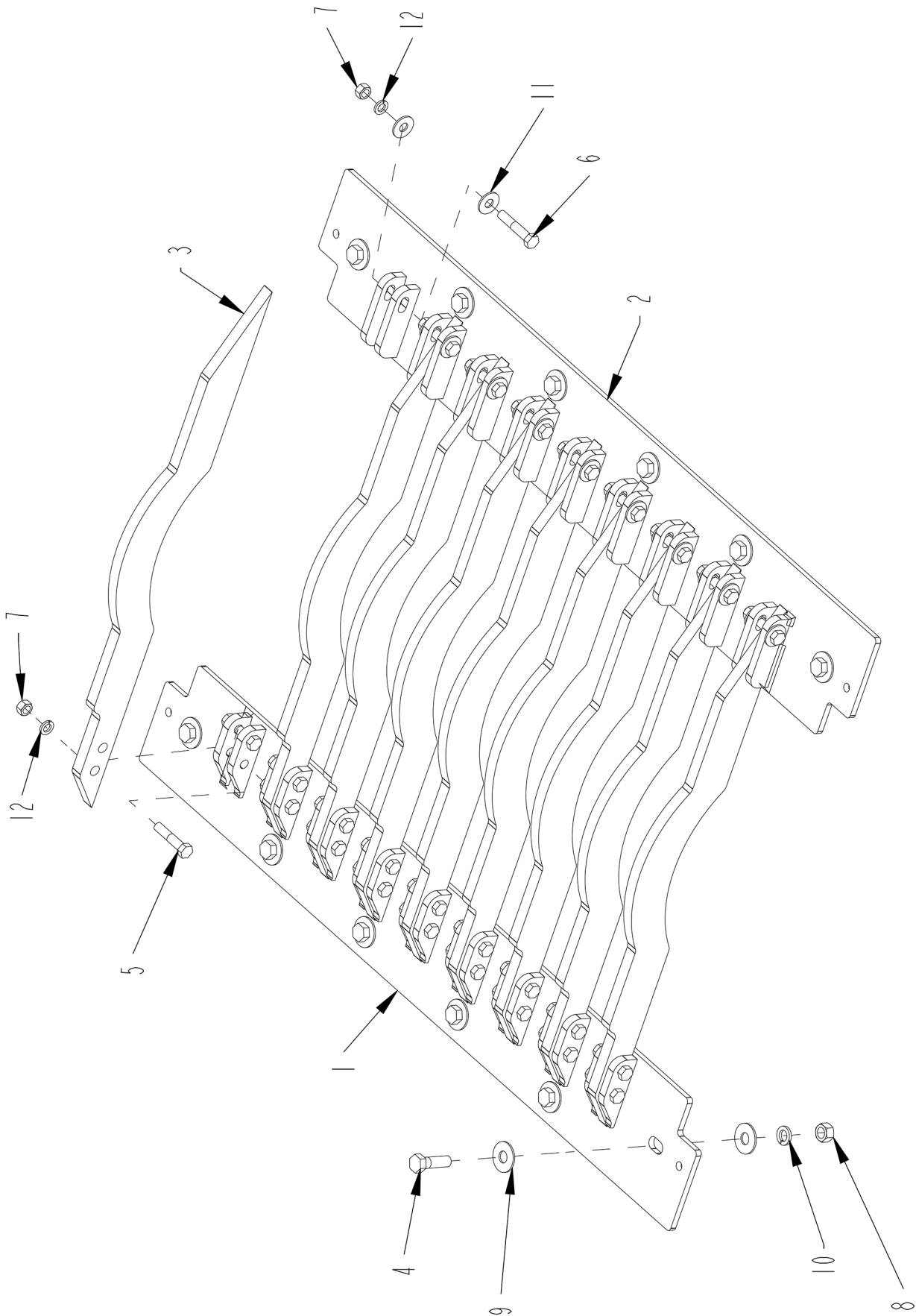
**MILL GRATE / SLUGBAR COMBINATION (OPTION)  
(FOR S.N. UP TO 1115070030)**



**MILL GRATE / SLUGBAR COMBINATION (OPTION)  
(FOR S.N. UP TO 1115070030)**

<b>ITEM</b>	<b>PART</b>	<b>QTY.</b>	<b>PART DESCRIPTION</b>
1	4501844	1	PL\SIDE\GRATE\MILL
2	4501845	5	BAR\GRATE\MILL
3	4502433	4	TOOTH\BSTR\SLG
4	4502434	2	TOOTH\BSTR\SLG\END
5	4502435	1	PL\SIDE\GRATE\MILL\BSTR\SLG\RMVBL
6	4800010	10	BOLT\HEX\5/8X2
7	4800070	10	BOLT\HEX\1/2X2-1/2
8	4800106	2	BOLT\HEX\5/8X1-1/2
9	4800351	11	BOLT\HEX\1/2X2-3/4
10	4900001	21	NUT\HEX\1/2\NC
11	4900005	10	NUT\HEX\5/8\NC
12	4900110	2	NUT\FLG\SERR\5/8\NC
13	5000002	14	WASH\FLAT\5/8
14	5000003	10	WASH\LOCK\5/8
15	5000004	10	WASH\FLAT\1/2
16	5000006	21	WASH\LOCK\1/2
	<b>4502436</b>		<b>GRATE\MILL\W\SLGBSTRS\OPTION</b>

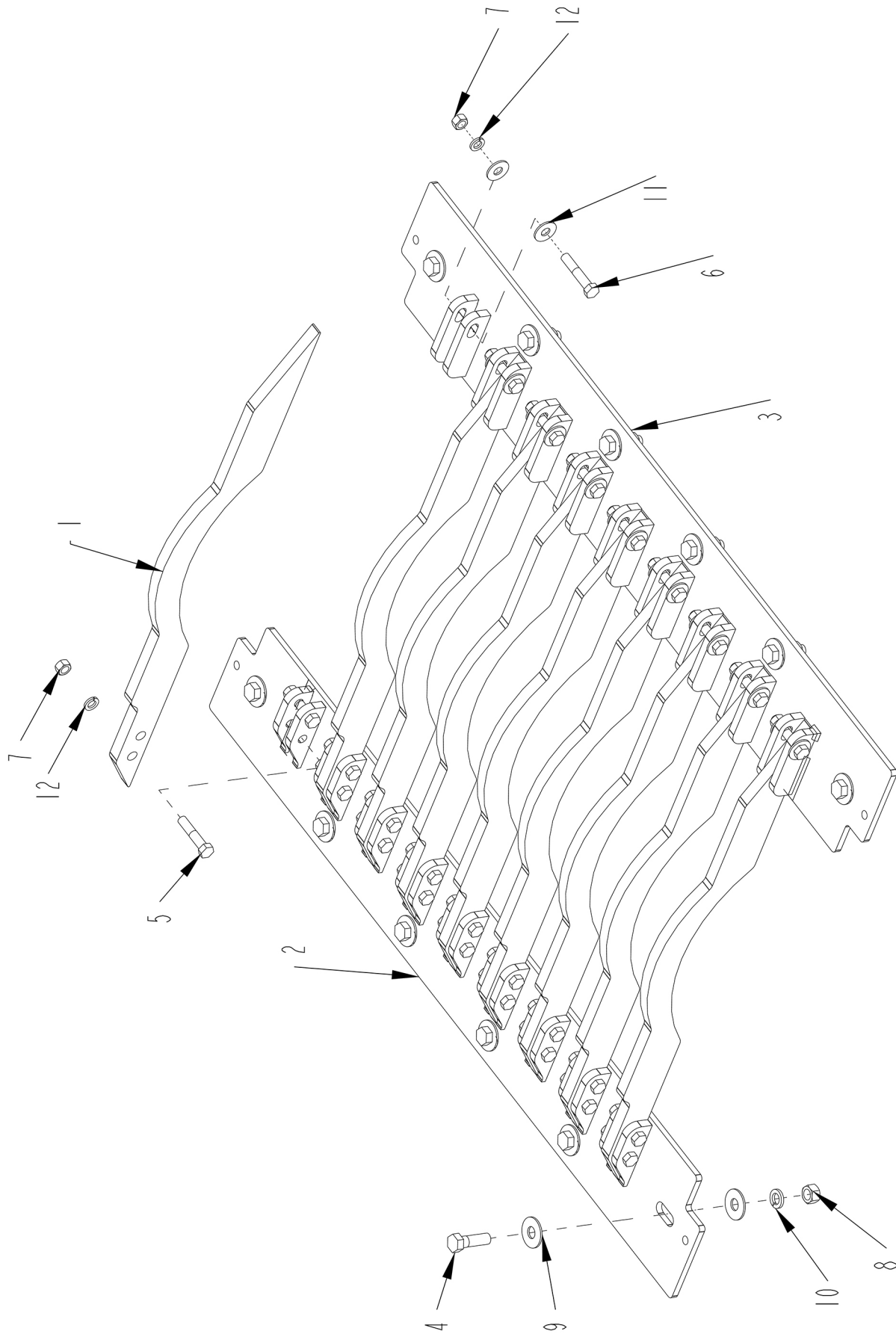
MILL GRATE - 9 BAR - 2-1/2" (FOR S.N. 1116071930 TO 1117090030)



**MILL GRATE - 9 BAR - 2-1/2" (FOR S.N. 1116071930 TO 1117090030)**

<b>ITEM</b>	<b>PART</b>	<b>QTY.</b>	<b>PART DESCRIPTION</b>
1	4502832	1	PL\SIDE\GRATE\MILL
2	4502834	1	PL\SIDE\GRATE\MILL\9 BAR
3	4502835	9	BAR\GRATE\MILL\9BAR
4	4800010	12	BOLT\HEX\5/8X2
5	4800070	18	BOLT\HEX\1/2X2-1/2
6	4800351	9	BOLT\HEX\1/2X2-3/4
7	4900001	27	NUT\HEX\1/2\NC
8	4900005	12	NUT\HEX\5/8\NC
9	5000002	24	WASH\FLAT\5/8
10	5000003	12	WASH\LOCK\5/8
11	5000004	18	WASH\FLAT\1/2
12	5000006	27	WASH\LOCK\1/2
	<b>4502284</b>		<b>GRATE\MILL\9BAR\2-1/2\ASSY</b>

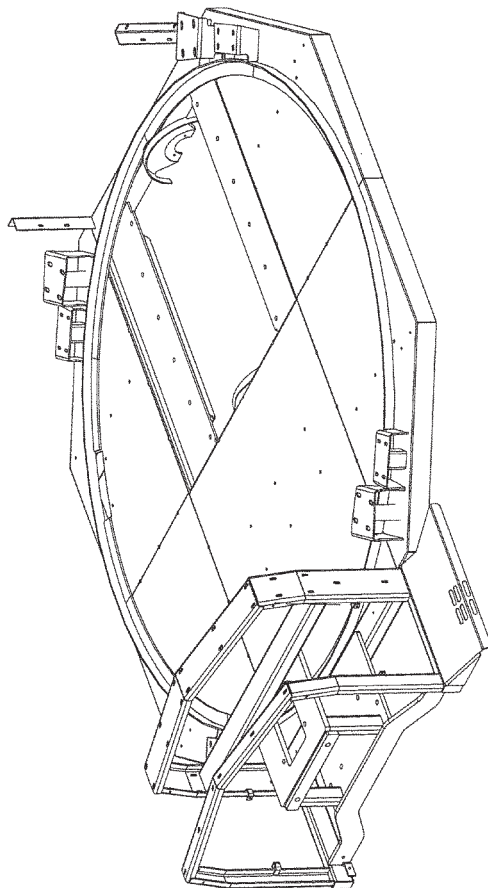
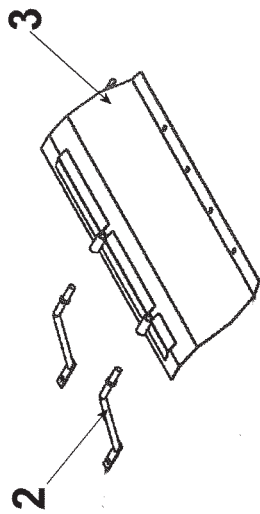
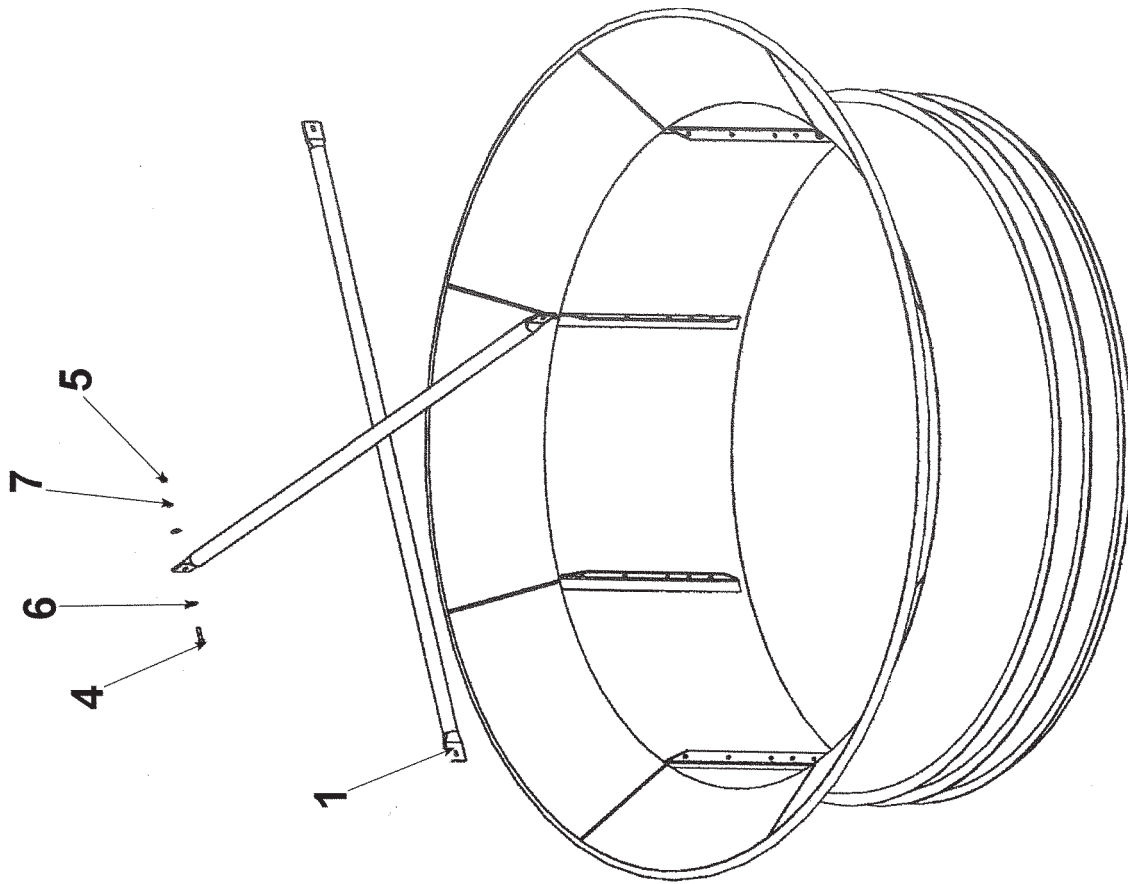
MILL GRATE - 9 BAR - 2-1/2" (FOR S.N. 1118090130 AND UP)



**MILL GRATE - 9 BAR - 2-1/2" (FOR S.N. 1118090130 AND UP)**

<b>ITEM</b>	<b>PART</b>	<b>QTY.</b>	<b>PART DESCRIPTION</b>
1	4502678	9	BAR\GRATE\MILL\9BAR
2	4502832	1	PL\SIDE\GRATE\MILL
3	4502834	1	PL\SIDE\GRATE\MILL\9 BAR
4	4800010	12	BOLT\HEX\5/8X2
5	4800070	18	BOLT\HEX\1/2X2-1/2
6	4800351	9	BOLT\HEX\1/2X2-3/4
7	4900001	27	NUT\HEX\1/2\NC
8	4900005	12	NUT\HEX\5/8\NC
9	5000002	24	WASH\FLAT\5/8
10	5000003	12	WASH\LOCK\5/8
11	5000004	18	WASH\FLAT\1/2
12	5000006	27	WASH\LOCK\1/2
	<b>4502284</b>		<b>GRATE\MILL\9BAR\2-1/2\ASSY</b>

**EAR CORN KIT (OPTION)**

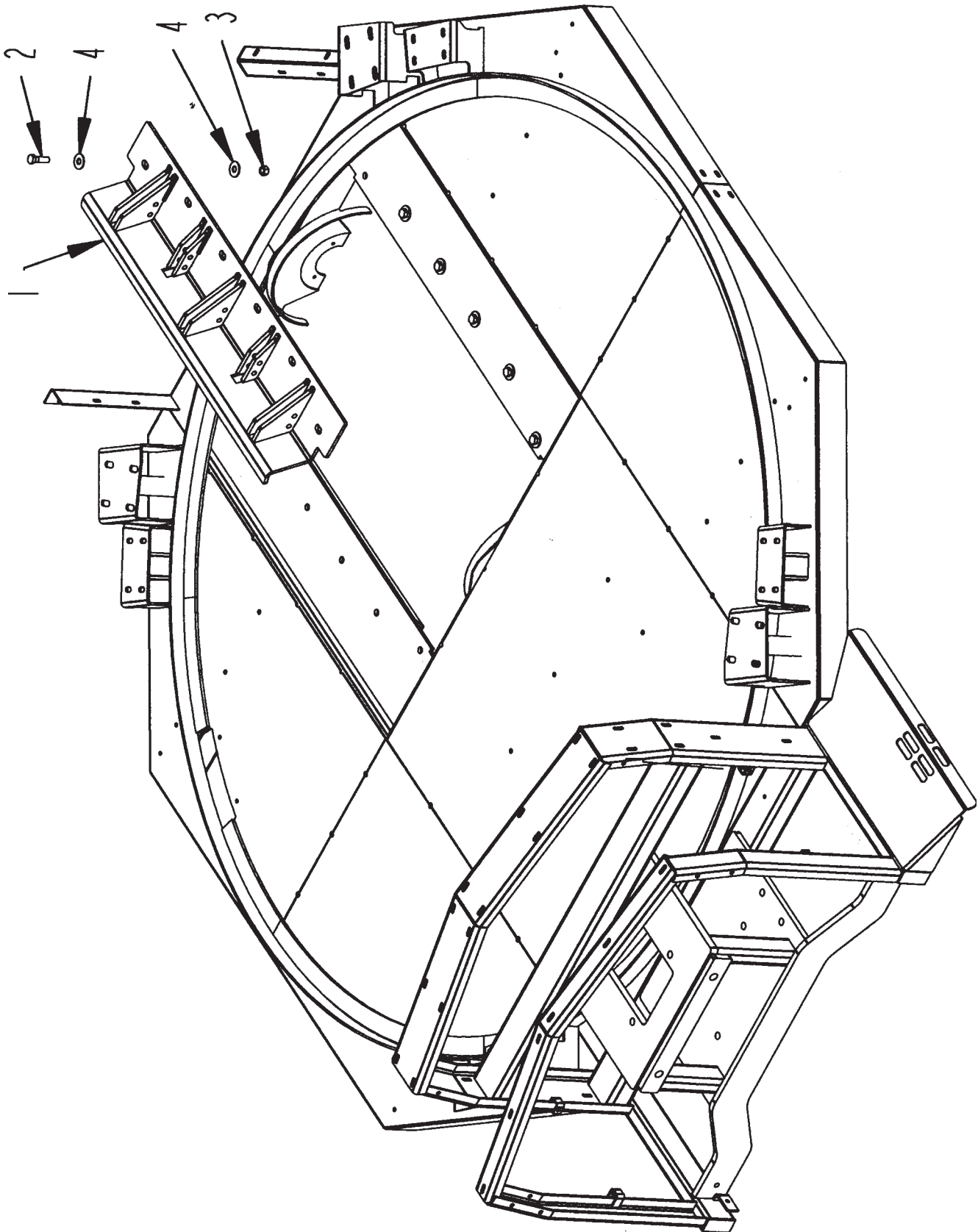


## EAR CORN KIT (OPTION)

ITEM	PART	QTY.	PART DESCRIPTION
1	4500128	2	PIPE\CROSS\2X107
2	4500751	2	BRKT\COVER\ROTOR\EARCORN
3	4501052	1	CVR\RTR\EARCORN\H1100E
4	4800114	4	BOLT\HEX\1/2X2
5	4900001	4	NUT\HEX\1/2\NC
6	5000004	8	WASH\FLAT\1/2
7	5000006	4	WASH\LOCK\1/2
	<b>4501053</b>		<b>AGTTR\EAR_CORN\KIT\H1130\H1100E\ DEALER_INSTALLED</b>

The Ear Corn Attachment is designed specifically for grinding ear corn. It should not be used when grinding hay, other bulk materials or small grains. This attachment fits directly over the rotor and bolts to the tub platform. Agitator bars inside the tub move ear corn to the rotor.

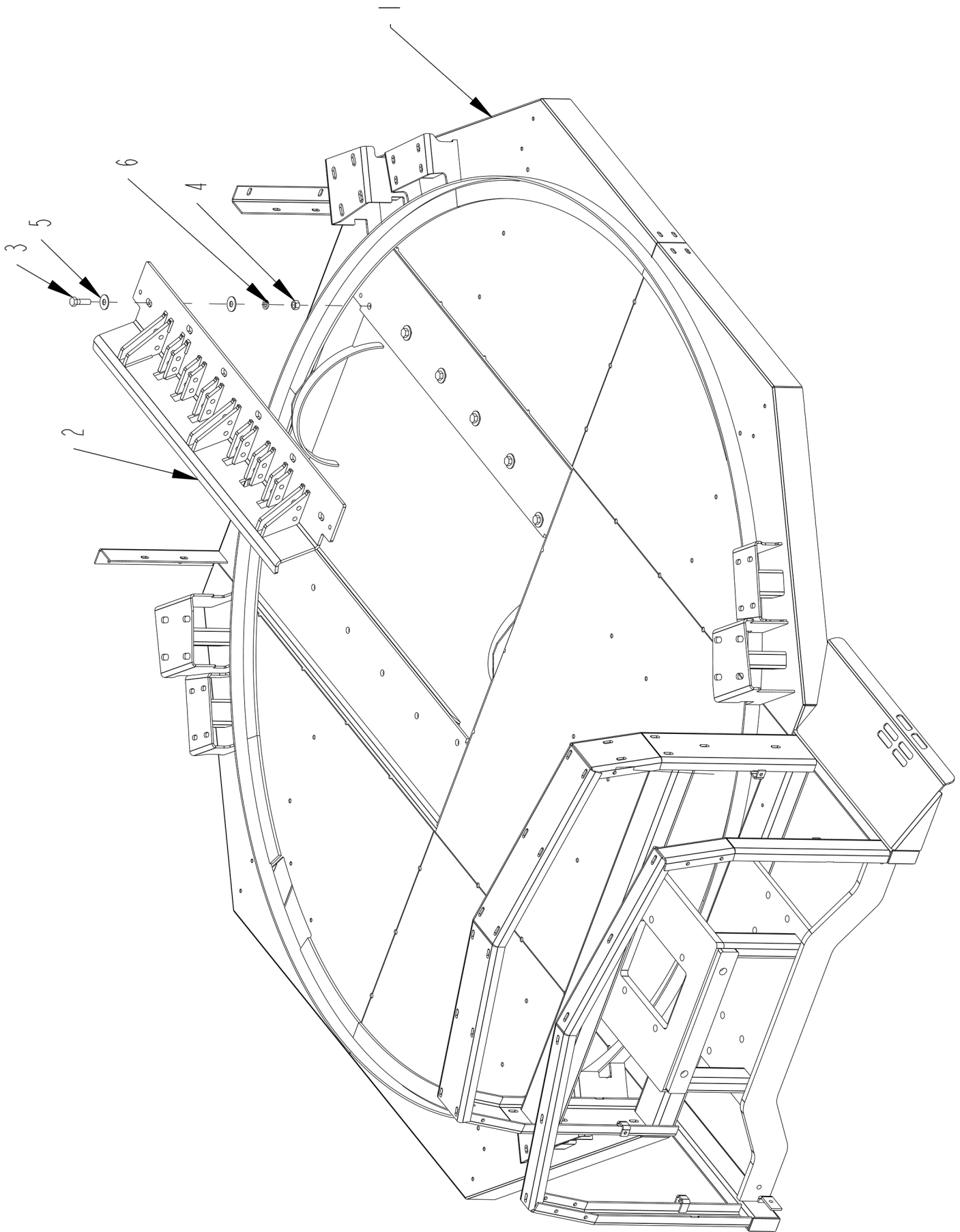
GEYSER PLATE (OPTION) (FOR S.N. UP TO 1115070030)



**GEYSER PLATE (OPTION) (FOR S.N. UP TO 1115070030)**

<b>ITEM</b>	<b>PART</b>	<b>QTY.</b>	<b>PART DESCRIPTION</b>
1	4501847	1	PL\GEYSER
2	4800010	6	BOLT\HEX\5/8X2
3	4900012	6	NUT\TPLCK\5/8\NC
4	5000002	12	WASH\FLAT\5/8

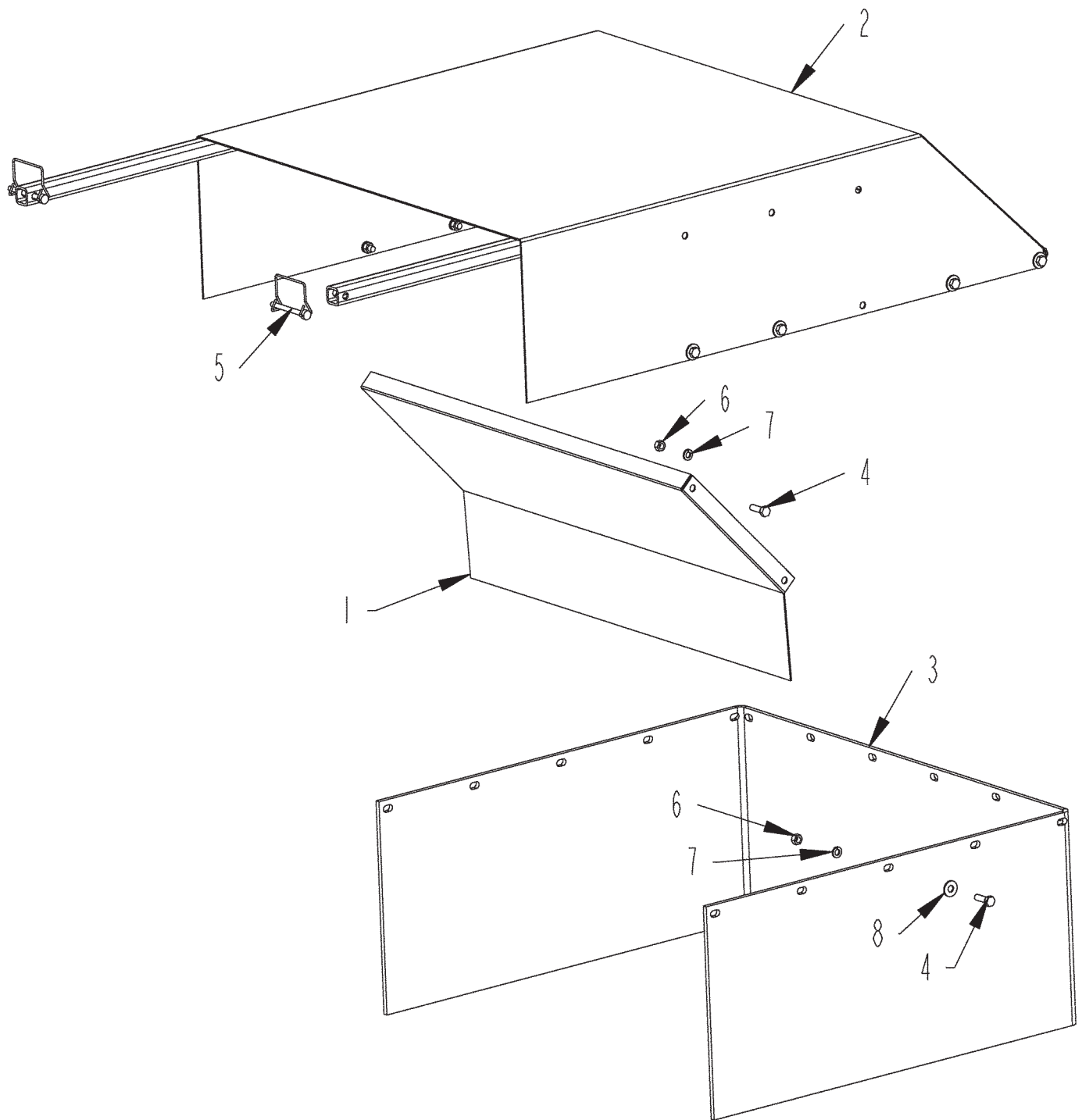
**GEYSER PLATE (OPTION) (FOR S.N. 1116071930 AND UP)**



**GEYSER PLATE (OPTION) (FOR S.N. 1116071930 AND UP)**

<b>ITEM</b>	<b>PART</b>	<b>QTY.</b>	<b>PART DESCRIPTION</b>
1	4502642	1	FRM\PLFRM\TILT\1130\RTR\REAR
2	4502839	1	PL\GEYSER\9 BAR
3	4800010	6	BOLT\HEX\5/8X2
4	4900005	6	NUT\HEX\5/8\NC
5	5000002	12	WASH\FLAT\5/8
6	5000003	6	WASH\LOCK\5/8

# MATERIAL GUIDE ASSEMBLY (OPTION)



## MATERIAL GUIDE ASSEMBLY (OPTION)

ITEM	PART	QTY.	PART DESCRIPTION
1	4501616	1	DEFL\GUIDE\MATL\CNVY\UPPR
2	4501617	1	GUIDE\MATL\CNVY\UPPR\24
3	4501618	1	BELT\GUIDE\MATL\CNVYR\UPPR
4	4800013	18	BOLT\HEX\5/16X1
5	4800559	2	PIN\LYNCH\5/16X2-1/2\W/SQ;WIRE;KEEPER
6	4900003	18	NUT\HEX\5/16\NC
7	5000022	18	WASH\LOCK\5/16
8	5000023	16	WASH\FLAT\5/16
	<b>4501609</b>		<b>GUIDE\DSCH\CNVYR\24\KIT\1150</b>

DECALS



<b>WARNING</b>	<b>ADVERTENCIA</b>
FOR YOUR PROTECTION KEEP ALL SHIELDS IN PLACE AND SECURED WHILE MACHINE IS OPERATING. MOVING PARTS WITHIN CAN CAUSE SEVERE PERSONAL INJURY.	PARA ASEGURAR SU PROTECCION, MANTENGA TODOS LOS PROTECTORES EN SU LUGAR Y ASEGURADOS MIENTRAS LA MAQUINA ESTE OPERANDO. LAS PIEZAS MOVILES INTERNAS PUEDEN CAUSAR LESIONES PERSONALES GRAVES.

6500040

<b>WARNING</b>	<b>ADVERTENCIA</b>
FOR YOUR PROTECTION AND SAFETY OF OTHERS, FOLLOW THESE SAFETY RULES: 1. Read and understand operator manual before operating machine. 2. Read and understand all safety warnings on machine. 3. Read and understand all safety warnings on attachments. 4. Read and understand all safety warnings on PTO shafts. 5. Read and understand all safety warnings on PTO shafts. 6. Read and understand all safety warnings on PTO shafts. 7. Read and understand all safety warnings on PTO shafts. 8. Read and understand all safety warnings on PTO shafts. 9. Read and understand all safety warnings on PTO shafts. 10. Read and understand all safety warnings on PTO shafts.	PARA SU PROTECCION Y LA SEGURIDAD DE OTROS, OBSERVE ESTAS NORMAS DE SEGURIDAD: 1. Lea y entienda el manual del operador antes de operar el equipo. 2. Lea y entienda todas las advertencias de seguridad en la máquina. 3. Lea y entienda todas las advertencias de seguridad en los accesorios. 4. Lea y entienda todas las advertencias de seguridad en los ejes de transmisión. 5. Lea y entienda todas las advertencias de seguridad en los ejes de transmisión. 6. Lea y entienda todas las advertencias de seguridad en los ejes de transmisión. 7. Lea y entienda todas las advertencias de seguridad en los ejes de transmisión. 8. Lea y entienda todas las advertencias de seguridad en los ejes de transmisión. 9. Lea y entienda todas las advertencias de seguridad en los ejes de transmisión. 10. Lea y entienda todas las advertencias de seguridad en los ejes de transmisión.

6500041

<b>WARNING</b>		<b>ADVERTENCIA</b>
<b>No Riders</b> Serious personal injury could result from riding on the machine.		<b>Pasajeros Prohibidos</b> Podrían resultar lesiones personales graves al viajar en la máquina.

6500043

**OIL LEVEL**  
**NIVEL DE ACEITE**

6500052

**ROTATION**  
**ROTATION**  
**ROTACION**  
**ROTACION**

6500056

**DANGER**  
ROTATING PARTS WITHIN CAN KILL OR DISMEMBER  
WAIT FOR ALL MOVEMENT TO STOP BEFORE SERVICING,  
UNCLOGGING OR INSPECTING MACHINE

6500082

**DANGER**  
  
**Rotating Driveline**  
Keep Away!  
Entanglement can cause serious injuries or death.  
Do Not Operate Without -  
\* All driveline guards, tractor and equipment shields in place.  
\* Drivelines securely attached at both ends.  
\* Drivelines guards that turn freely on driveline.

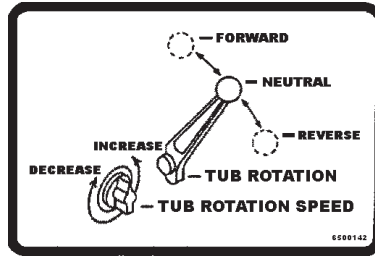
6500085

**HYDRAULIC OIL**

6500124



6500363



6500142

	<b>WARNING</b> THROWN OBJECT HAZARD To prevent serious injury or death, DO NOT RAISE THE TUB WITH ROTATION TO FORWARD OR REVERSE PTO. 1. Do not raise the tub with rotation to forward or reverse PTO. 2. Do not raise the tub with rotation to forward or reverse PTO. 3. Do not raise the tub with rotation to forward or reverse PTO. 4. Do not raise the tub with rotation to forward or reverse PTO.	<b>ADVERTENCIA</b> PELIGRO DE OBJETOS DESPEDIDOS No eleve la caja cuando el PTO está en posición de avance o reversa. 1. No eleve la caja cuando el PTO está en posición de avance o reversa. 2. No eleve la caja cuando el PTO está en posición de avance o reversa. 3. No eleve la caja cuando el PTO está en posición de avance o reversa. 4. No eleve la caja cuando el PTO está en posición de avance o reversa.
--	---	---

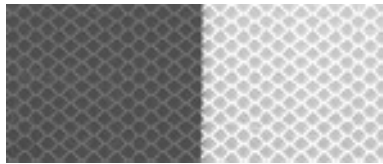
6500209

	<b>WARNING</b> OVERHEAD CONVEYOR HAZARD To prevent serious injury or death, DO NOT STAND UNDER OR IN THE PATH OF THE CONVEYOR BELT WHILE IT IS RUNNING. 1. Do not stand under or in the path of the conveyor belt while it is running. 2. Do not stand under or in the path of the conveyor belt while it is running. 3. Do not stand under or in the path of the conveyor belt while it is running. 4. Do not stand under or in the path of the conveyor belt while it is running.	<b>ADVERTENCIA</b> PELIGRO DE CINTA TRANSPORTADORA No se quede bajo o en el camino de la cinta transportadora cuando esta está funcionando. 1. No se quede bajo o en el camino de la cinta transportadora cuando esta está funcionando. 2. No se quede bajo o en el camino de la cinta transportadora cuando esta está funcionando. 3. No se quede bajo o en el camino de la cinta transportadora cuando esta está funcionando. 4. No se quede bajo o en el camino de la cinta transportadora cuando esta está funcionando.
--	---	---

6500214

**WARNING**  
  
**HIGH-PRESSURE FLUID HAZARD**  
To prevent serious injury or death:  
Relieve pressure on system before repairing, adjusting or disconnecting.  
Wear proper hand and eye protection when searching for leaks. Use wood or cardboard instead of hands.  
Keep all components in good repair.

6500220



6500245

	<b>WARNING</b> TIPPING HAZARD To prevent serious injury or death: 1. Do not tilt with material in tub. 2. Do not tilt on sloped ground. 3. Do not tilt on soft ground. 4. Do not use other equipment to assist tilt.	<b>ADVERTENCIA</b> RIESGO DE VUELCO Para evitar el riesgo de sufrir lesiones graves o mortales: 1. No inclinar la máquina con material en la tolva. 2. No inclinar la máquina sobre una pendiente. 3. No inclinar la máquina sobre suelo blando. 4. No usar otros equipos para ayudar a inclinar la máquina.
--	--	--

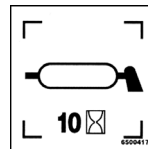
6500282

	<b>WARNING</b> To prevent serious injury or death during operation: 1. Do not overfill the tub. 2. Do not engage the grinder or motor machine adjustments while it is being loaded.	<b>ADVERTENCIA</b> Para evitar el riesgo de sufrir lesiones graves o mortales: 1. No llenar la tolva en exceso para evitar derrames. 2. No accionar a la trituradora ni ajustar la máquina mientras está siendo cargada.
--	--	---

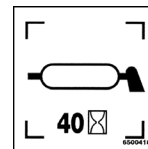
6500283

Grease rotor bearings every 10 hours with Mobil XHP 222 Grease. If substitute grease must be used, use a Lithium #2 base. Administer 6-8 pumps from a grease gun. Bearing should purge a small amount of grease while running. Do not over grease; this will cause overheating within the bearing.

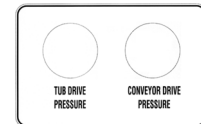
6500416



6500417



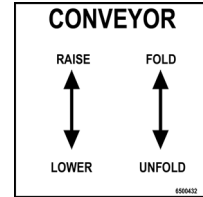
6500418



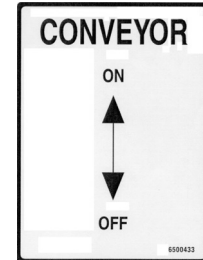
6500456

	<b>CAUTION</b> ADJUST TRACTOR DRAWBAR SO THAT THE DISTANCE FROM THE END OF THE PTO SHAFT ON THE TRACTOR TO THE CENTER OF THE DRAWBAR HITCH PIN IS EQUAL TO THE DISTANCE SHOWN IN DIAGRAM. SEE OWNER'S MANUAL FOR MORE INFORMATION.
	<b>PRECAUCION</b> AJUSTAR LA BARRA DE TIRO DEL TRACTOR DE MODO QUE LA DISTANCIA DEL EXTREMO DEL EJE DE LA TDF DEL TRACTOR AL CENTRO DEL PASADOR DEL ENGANCHE DE LA BARRA DE TIRO SEA IGUAL A LA DISTANCIA INDICADA EN EL DIAGRAMA. VER EL MANUAL DEL OPERADOR PARA MAS INFORMACION.

6500440



6500432









6500433

**H-1130**

6500442

**DECALS**

	ITEM	PART	QTY.	PART DESCRIPTION
 <p><b>WARNING</b> Pinch Point Stay back</p> <p>6500339</p>	1	6500020	3	DECAL\LOGO\HYBSTR\SNBRS\3
	2	6500040	2	DECAL\WARN\SHIELD\PROT
	3	6500041	1	DECAL\WARN\PROTECTION
	4	6500043	1	DECAL\WARN\NO;RIDERS
	5	6500052	1	DECAL\INFO\OIL;LEVEL
	6	6500056	2	DECAL\INFO\ROTATION\STR
	7	6500082	4	DECAL\WARN\ROTATN;PART;>
 <p><b>WARNING</b> Moving parts can crush and cut. Keep hands clear.</p> <p>6500488</p>	8	6500085	1	DECAL\DNGR\ROTATNG;DR-LNE
	9	6500124	1	DECAL\INFO\HYD;OIL
	10	6500142	1	DECAL\INFO\TUB;ROTATON;>
	11	6500209	1	DECAL\WARN\THROWN;OBJCT;>
	12	6500214	2	DECAL\WARN\OVRHED;CNVYR;>
	13	6500220	1	DECAL\WARN\HI;PRESS;FLUID
	14	6500245	8	DECAL\TAPE\REFL\RED\WHT
 <p><b>WARNING</b> No Step. Do not step, stand or sit on this surface. May cause injury and/or equipment damage.</p> <p>6500490</p>	15	6500282	1	DECAL\WARN\TIPPING;HZRD
	16	6500283	1	DECAL\WARN\OVERLOAD;TUB
	17	6500302	20 ft.	DECAL\LOGO\STRIP\3\RD&BLK
	18	6500363	3	DECAL\LOGO\BIBBITE\UNVRSL
	19	6500416	2	DECAL\BRG\RTR\GREASE\10HRS
	20	6500417	4	DECAL\GREASE\10 HRS
	21	6500418	7	DECAL\GREASE\40 HRS
 <p><b>WARNING</b> Noise hazard. Ear protection required.</p> <p>6500489</p>	22	6500432	1	DECAL\CNVYR\H1130\GP50
	23	6500433	1	DECAL\CNVYR\OFF\ON\H1130
	24	6500440	1	DECAL\CAUT\ADJ_DRWBAR\16&20
	25	6500442	3	DECAL\LOGO\H1130
	26	6500456	1	DECAL\PRESSURE
	27	6500118	1	DECAL\DNGR\OBJCTS;THROWN
	28	6500339	4	DECAL\WARN\PINCH;POINT
 <p>29</p>	6500457	1	DECAL\INFO\5MPH ( For Electric Model Only)	
	30	6500488	1	DECAL\WARN\PARTS\MOVING
	31	6500489	1	DECAL\WARN\PEP\HEARING
	32	6500490	1	DECAL\WARN\NO STEP
	33	6500497	1	DECAL\EXTINGUISHER\FIRE
	34	6500118	1	DECAL\DNGR\OBJCTS;THROWN
	6500436			DECAL\KIT\H1130
 <p>6500497</p>	<b>NOT SHOWN</b>			
		7500077		PAINT\YELLOW\SPRAY\12OZ
		7500092		PAINT\YELLOW\QUART
		7500091		PAINT\YELLOW\GALLON
		7500078		PAINT\RED\SPRAY\12OZ
		7500105		PAINT\RED\QUART
		7500104		PAINT\RED\GALLON

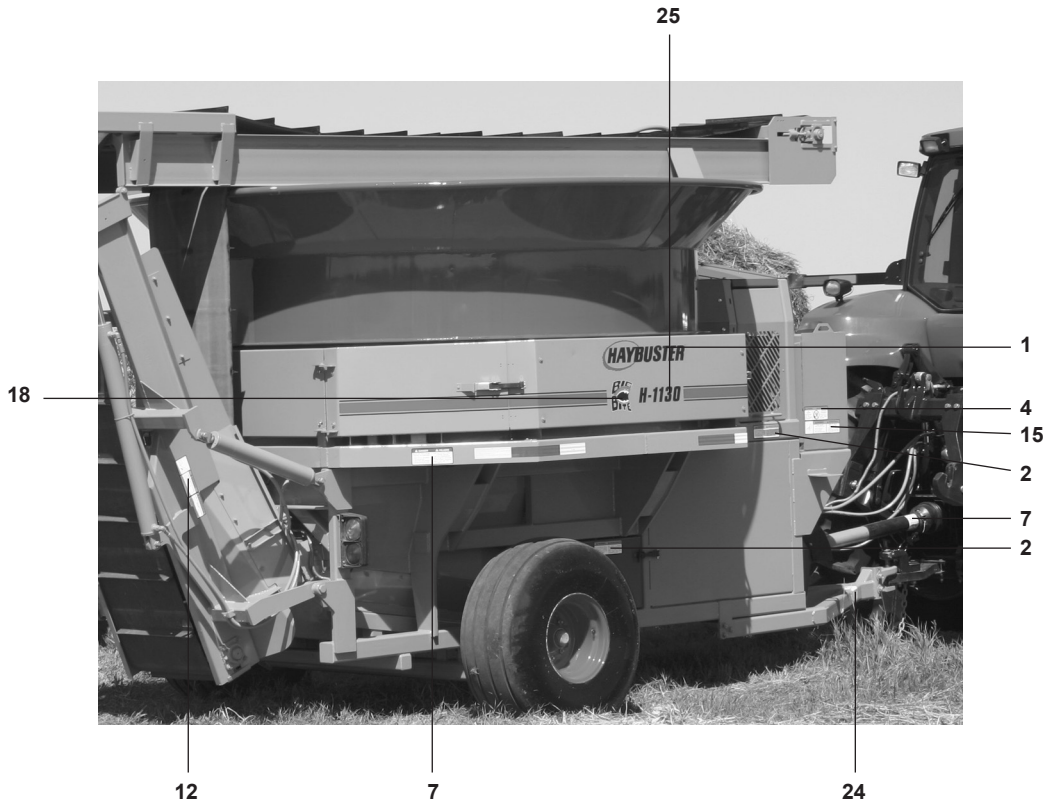
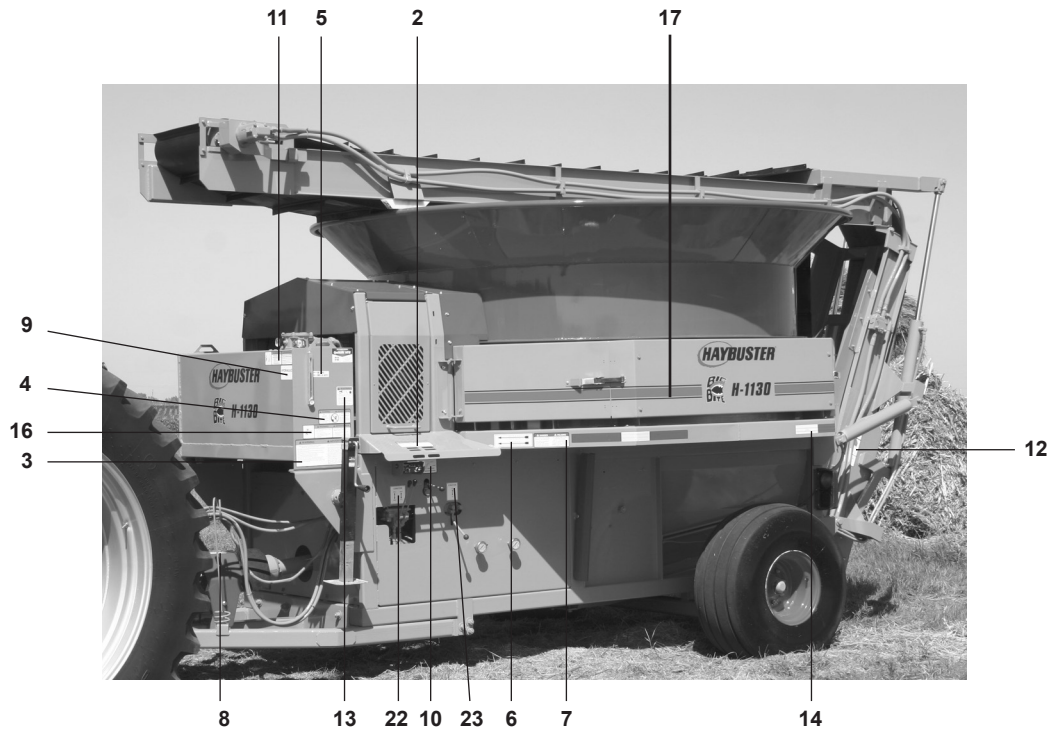


6500118

INFORMATION NOT FOR ROAD USE DO NOT EXCEED 5 MPH  
INFORMACIÓN NO DESTINADO A USO EN VÍAS PÚBLICAS NO EXCEDA 8 km/h

6500457

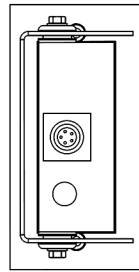
# DECAL LOCATIONS



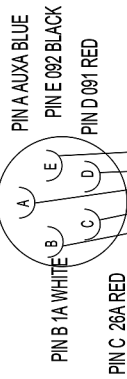
5700845

1130 HARNESS

GOVERNOR - 4300034



GOVERNOR CONNECTOR



GOVERNOR VALVE

4300078

091 RED 2-POLE M/P 150 TOWER "A" 3"  
092 BLK 2-POLE M/P 150 TOWER "B" 3"  
1 PAIR SHIELDED WIRES

TAIL LIGHTS

INCADESCENT BULB  
5700715 RED IS ON RIGHT SIDE OF ASSEMBLY  
5700716 RED IS ON LEFT SIDE OF ASSEMBLY  
LEDs  
5701068 LED RED IS ON RIGHT SIDE OF ASSEMBLY  
5701069 LED RED IS ON LEFT SIDE OF ASSEMBLY

RIGHT SIDE

"CLEAR" BLK (3") SEAL END  
"STOP" RED - #2  
"GRND" WHT - #4  
"RTRN" GRN - #3  
"TAIL" BRN - #1



LEFT SIDE



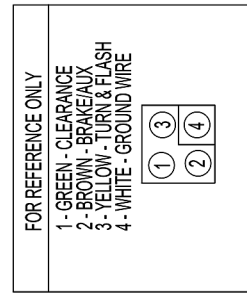
7-PIN PLUG 5700010  
SPRING RELIEF 5700829

"TAIL" BRN (3") pin 6  
"RTRN" GRN (3") pin 5  
"STOP" RED (3") pin 4  
"LTRN" YEL (3") pin 3

"GRND" WHT (3") pin 1 — TO TRACTOR GROUND  
"AUX" BLUE (3") pin 7  
TO TRACTOR KEY POWER

SELECTOR VALVE

4000429  
1 B WHITE PIN 2 (3")  
8 ORANGE, PIN 1 (3")



TUB VALVE

4000431  
AUX B BLUE #10 RING (3")  
8 ORANGE #10 RING (3")

# 5700902

Optional power harness for 5700845

08/05/2009 NEW HARNESS

ALL WIRES ARE 14 GAUGE

Black clamp

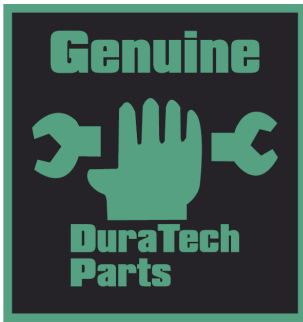
Red clamp

"GRND" WHT (3") pin 1

"AUX" BLUE (3") pin 7

7-pin receptacle 5700011

Boot Waytek 37679 or equivalent

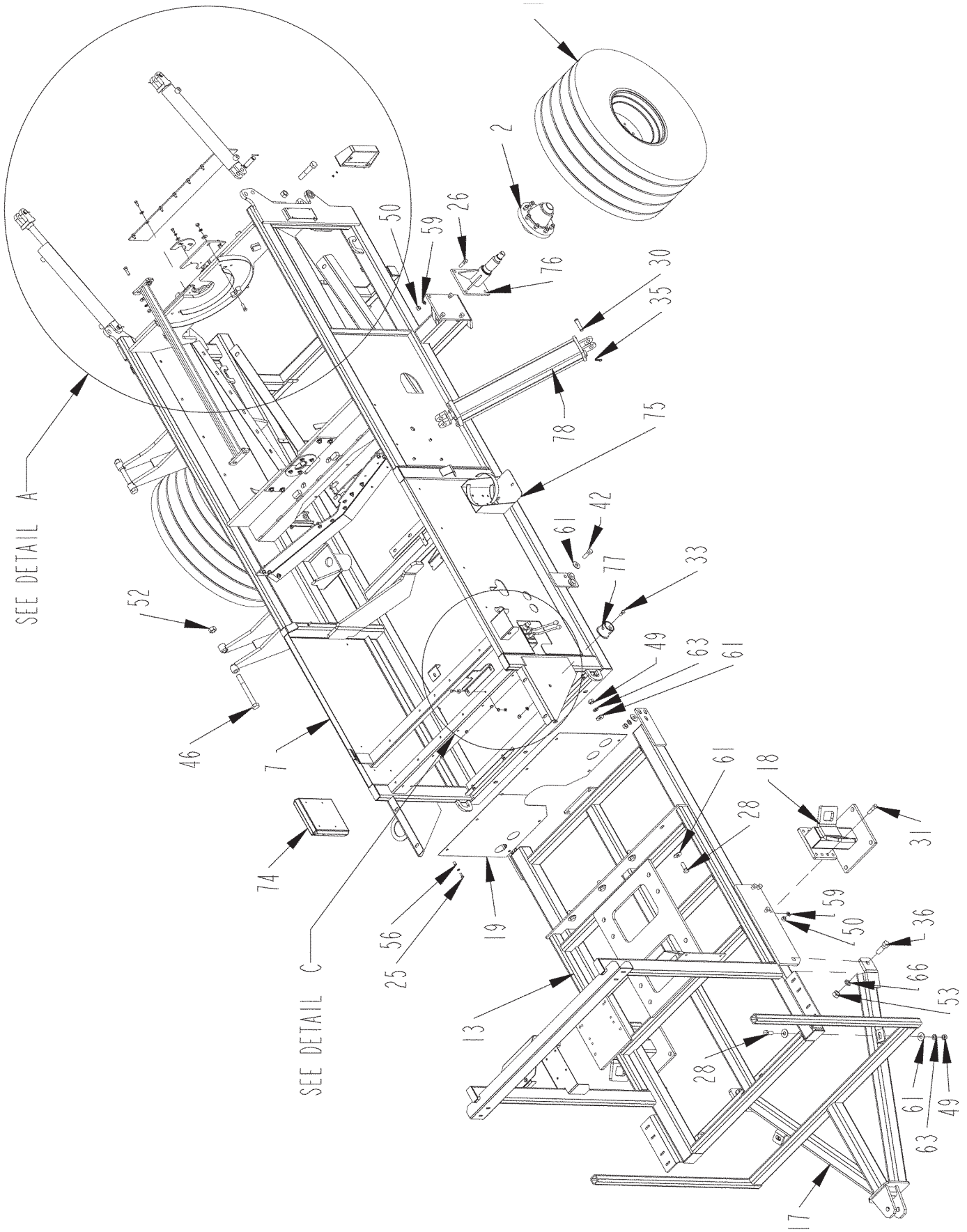


***HAYBUSTER***<sup>®</sup>

**H-1130<sup>™</sup>**  
**Stationary Electric Tub**  
**Grinder Supplement**

**Parts Reference**

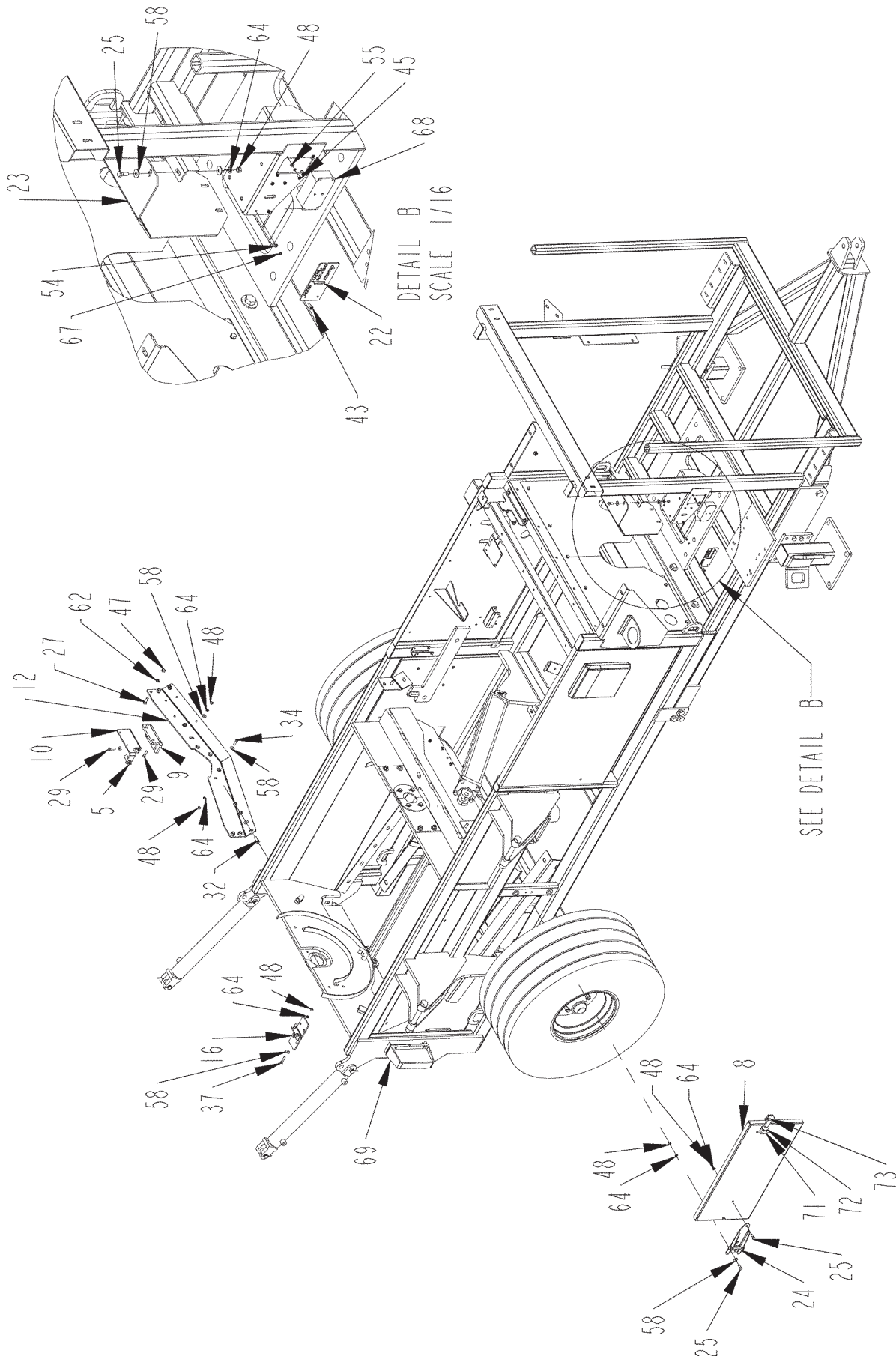
ELECTRIC MAINFRAME ASSEMBLY #1



# ELECTRIC MAINFRAME ASSEMBLY # 1

ITEM	PART	QTY.	PART DESCRIPTION
1	2600861	2	WHL\ASSY\16.5SLX\16.1X14PLY8BOLT-WHL\16.1X14\3/8POS (SEE WHEEL AND HUB ASSEMBLY)
2	2900140	2	HUB\ASSY\H817\8BOLT\8"B.C.16"PILOT (SEE WHEEL AND HUB ASSEMBLY)
3	4000477	1	VALVE\HYD\2-BANK\W\SWTCH\NORMOPEN
4	4100030	4	PIN 1" X 3-1/2" HYD. CYL.
5	4300088	1	SENSOR\MAG\W\HARDWARE
6	4501838	1	GUIDE\SCRN
7	4502300	1	FRMM\MAIN\H1100SS
8	4502336	1	DOOR\ACCESS\TNSNR
9	4502405	1	PL\IMNT\PKP\SPD
10	4502421	1	BRCKT\IMNT\PKP\SPD
11	4502430	1	BELT\SEAL\TRNSTN\CNVYR
12	4502439	1	ANGL\CRSS\FRMM\ID
13	4502614	1	PLTFRM\MTR\ELEC (THRU SN 0650)
14	4502615	4	PL\SEAL\ADJ\SHFT\TRTR
15	4502616	4	SEAL\SHAFT\3-1/4\IRTR\NYLN
16	4502619	1	MNT\MN\FLD\HOSE\HYD
17	4502624	1	HITCH\ELEC (THRU SN 0650)
18	4502625	2	STND\FR\FRMELEC
19	4502626	2	CVR\FR\ELEC
20	4502646	1	BRCKT\IMNT\SWTCH\ILMT
21	4502647	1	CATCH\ARM\SWTCH\ILMT
22	4502648	1	PLATE\FACE\STATUS\ROTOR
23	4502649	1	CVR\VLV\TUB
24	4703579	1	HINGE\ASSY\FAB\3-1/2
25	4800003	26	BOLT\HEX\3/8X1
26	4800010	8	BOLT\HEX\5/8X2
27	4800018	4	BOLT\HEX\1/2X1-1/4
28	4800033	6	BOLT\HEX\3/4X2
29	4800034	4	BOLT\HEX\3/8X1-1/2
30	4800046	1	PIN\CLEVIS\3/4X3
31	4800079	8	BOLT\HEX\5/8X2-1/2
32	4800082	10	BOLT\HEX\1/2X1-1/2
33	4800085	1	BOLT\HEX\1/2X1
34	4800098	4	BOLT\HEX\3/8X1-1/4\INC
35	4800107	1	PIN\HAIR\1/8(#9)
36	4800140	2	BOLT\HEX\1X3\INC
37	4800142	2	BOLT\HEX\3/8X1-3/4
38	4800164	8	BOLT\HEX\3/8X3/4
39	4800178	2	BOLT\HEX\1/2X1-3/4
40	4800203	8	PIN\COT\5/32X2
41	4800277	8	BOLT\HEX\1/4X1
42	4800283	6	BOLT\HEX\3/4X2-1/4
43	4800496	4	SCRIPAN\SLOT#\10X3/4\INC
44	4800546	2	BOLT\HEX\1X5\INC
45	4800588	4	SCR\RD\SLOT#\10-32X1/2
46	4800601	2	BOLT\HEX\1X9\INC
47	4900001	19	NUT\HEX\1/2\INC
48	4900002	20	NUT\HEX\3/8\INC
49	4900004	12	NUT\HEX\3/4\INC
50	4900005	16	NUT\HEX\5/8\INC
51	4900009	8	NUT\HEX\1/4\INC
52	4900015	2	NUT\NYLCK\1\INC
53	4900031	2	NUT\HEX\1\INC
54	4900072	4	NUT\HEX\#10\INC
55	4900077	4	NUT\HEX\#10\INF
56	4900082	9	NUT\INSERT\3/8\1.027X.150GR
57	4900127	2	NUT\PLCK\1\INC
58	5000001	47	WASH\FLAT\3/8
59	5000003	16	WASH\LOCK\5/8
60	5000004	12	WASH\FLAT\1/2
61	5000005	24	WASH\FLAT\3/4
62	5000006	19	WASH\LOCK\1/2
63	5000012	12	WASH\LOCK\3/4
64	5000019	37	WASH\LOCK\3/8
65	5000024	8	WASH\LOCK\1/4
66	5000053	2	WASH\LOCK\1
67	5000104	8	WASH\LOCK\#10
68	5700230	1	BOX\CNTRL\SAFETY SHUTDOWN
69	5700715	1	KIT\LIGHT
70	5700716	1	KIT\LIGHT
71	7500166	1	LATCH\RBBR\6
72	7500190	1	LATCH\RBBR\CATCH\6
73	7500347	1	LATCH\RBBR\MNT\6
74	7500590	1	ENCL\OPS\8-1/2X11X1-5/8
75	7500853	1	BRKT\EXT\INGUISHER\20LB
76	8101600	2	SPNDL\2800
77	8101748	1	BRKT\STRG\JACK
78	4100144	1	CYL\HYD\4X30\1-3/4 ROD\CLEVIS ENDS\O-RING PORTS
79	4100261	2	CYL\HYD\3X20\1-1/2ROD -CANADIAN TOOL & DIE
79A	4100328		CYL\HYD\3X20\1-1/2ROD -RAM INDUSTRIES
	<b>NOT SHOWN</b>		
	7501068	4	GRMT\RBBR\3-5/8X3ID\3/8T

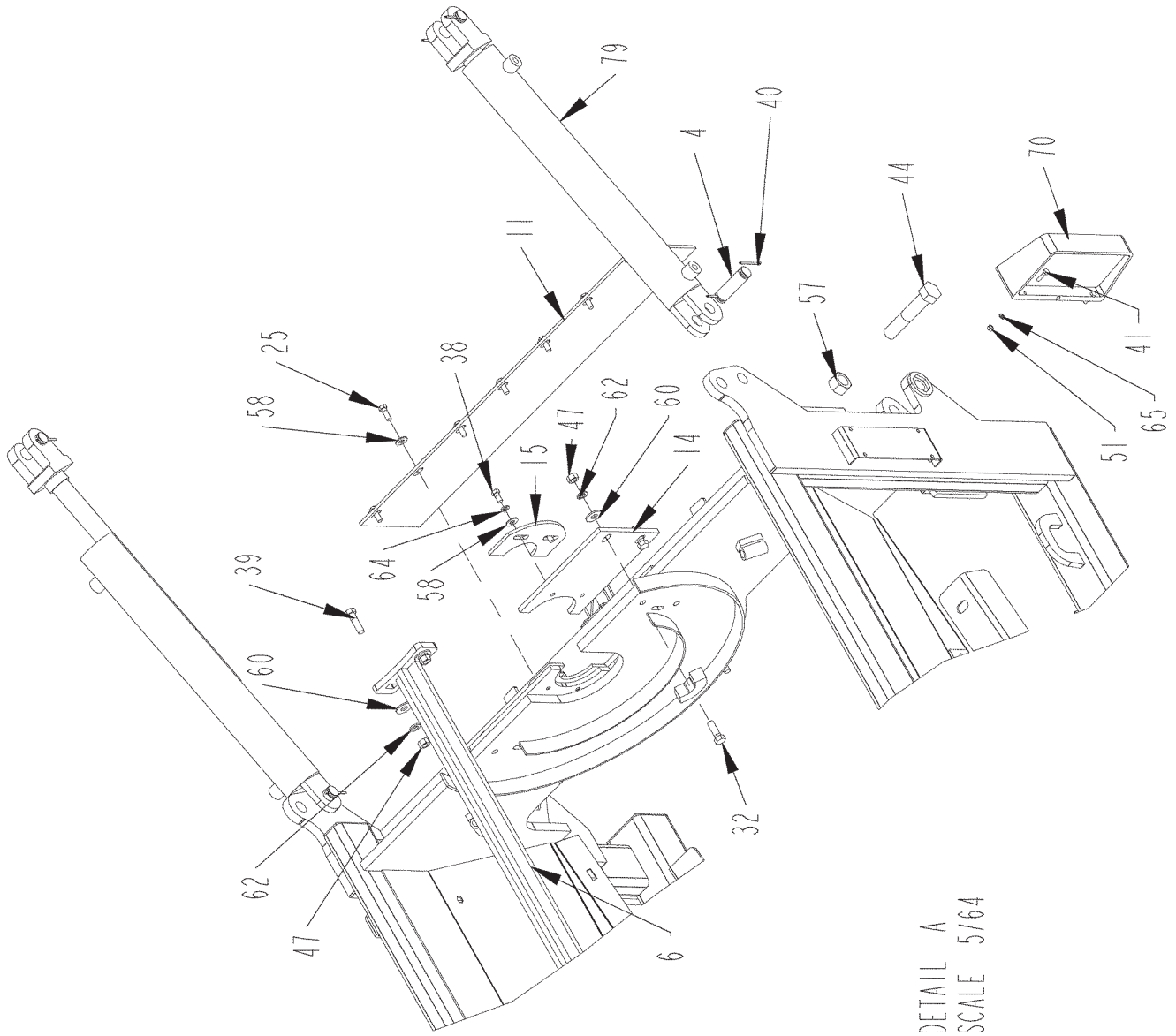
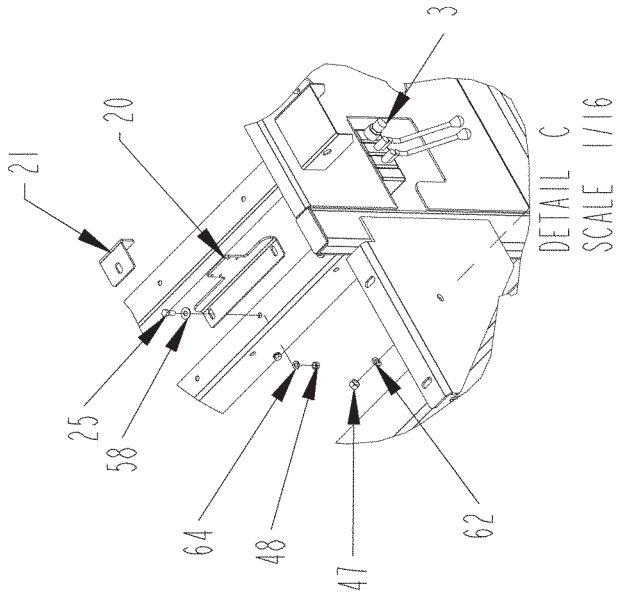
# ELECTRIC MAINFRAME ASSEMBLY #2



## ELECTRIC MAINFRAME ASSEMBLY #2

ITEM	PART	QTY.	PART DESCRIPTION
1	2600861	2	WHL\ASSY\16.5SLX16.1X14PLY8BOLT-WHL\16.1X14\3/8POS (SEE WHEEL AND HUB ASSEMBLY)
2	2900140	2	HUB\ASSY\H817\8BOLT\8"B.C.\6"PILOT (SEE WHEEL AND HUB ASSEMBLY)
3	4000477	1	VALVE\HYD\2-BANK\W\SWTCH\NORMOPEN
4	4100030	4	PIN 1" X 3-1/2" HYD. CYL.
5	4300088	1	SENSOR\MAG\W\HARDWARE
6	4501838	1	GUIDE\SCRN
7	4502300	1	FRM\MAIN\H1100SS
8	4502336	1	DOOR\ACCESS\TNSNR
9	4502405	1	PL\MNT\PKP\SPD
10	4502421	1	BRCKT\MNT\PKP\SPD
11	4502430	1	BELT\SEAL\TRN\STN\CNVYR
12	4502439	1	ANGL\CRSS\FRM\MID
13	4502614	1	PLTFRM\MTR\ELEC (THRU SN 0650)
14	4502615	4	PL\SEAL\ADJ\SHFT\RTR
15	4502616	4	SEAL\SHAFT\3-1/4\RTR\NYLN
16	4502619	1	MNT\MNFLD\HOSE\HYD
17	4502624	1	HITCH\ELEC (THRU SN 0650)
18	4502625	2	STND\FR\FRM\ELEC
19	4502626	2	CVR\FR\ELEC
20	4502646	1	BRCKT\MNT\SWTCH\LMT
21	4502647	1	CATCH\ARM\SWTCH\LMT
22	4502648	1	PLATE\FACE\STATUS\ROTOR
23	4502649	1	CVR\VLV\TUB
24	4703579	1	HINGE\ASSY\FAB\3-1/2
25	4800003	26	BOLT\HEX\3/8X1
26	4800010	8	BOLT\HEX\5/8X2
27	4800018	4	BOLT\HEX\1/2X1-1/4
28	4800033	6	BOLT\HEX\3/4X2
29	4800034	4	BOLT\HEX\3/8X1-1/2
30	4800046	1	PIN\CLEVIS\3/4X3
31	4800079	8	BOLT\HEX\5/8X2-1/2
32	4800082	10	BOLT\HEX\1/2X1-1/2
33	4800085	1	BOLT\HEX\1/2X1
34	4800098	4	BOLT\HEX\3/8X1-1/4\NC
35	4800107	1	PIN\HAIR\1/8(#9)
36	4800140	2	BOLT\HEX\1X3\NC
37	4800142	2	BOLT\HEX\3/8X1-3/4
38	4800164	8	BOLT\HEX\3/8X3/4
39	4800178	2	BOLT\HEX\1/2X1-3/4
40	4800203	8	PIN\COT\5/32X2
41	4800277	8	BOLT\HEX\1/4X1
42	4800283	6	BOLT\HEX\3/4X2-1/4
43	4800496	4	SCR\PAN\SLOT\#10X3/4\NC
44	4800546	2	BOLT\HEX\1X5\NC
45	4800588	4	SCR\RD\SLOT\#10-32X1/2
46	4800601	2	BOLT\HEX\1X9\NC
47	4900001	19	NUT\HEX\1/2\NC
48	4900002	20	NUT\HEX\3/8\NC
49	4900004	12	NUT\HEX\3/4\NC
50	4900005	16	NUT\HEX\5/8\NC
51	4900009	8	NUT\HEX\1/4\NC
52	4900015	2	NUT\NYLCK\1\NC
53	4900031	2	NUT\HEX\1\NC
54	4900072	4	NUT\HEX\#10\NC
55	4900077	4	NUT\HEX\#10\WF
56	4900082	9	NUT\INSERT\3/8\027X.150GR
57	4900127	2	NUT\TPLCK\1\NC
58	5000001	47	WASH\FLAT\3/8
59	5000003	16	WASH\LOCK\5/8
60	5000004	12	WASH\FLAT\1/2
61	5000005	24	WASH\FLAT\3/4
62	5000006	19	WASH\LOCK\1/2
63	5000012	12	WASH\LOCK\3/4
64	5000019	37	WASH\LOCK\3/8
65	5000024	8	WASH\LOCK\1/4
66	5000053	2	WASH\LOCK\1
67	5000104	8	WASH\LOCK\#10
68	5700230	1	BOX\CNTRL\SAFETY SHUTDOWN
69	5700715	1	KIT\LIGHT
70	5700716	1	KIT\LIGHT
71	7500166	1	LATCH\IRBBR\6
72	7500190	1	LATCH\IRBBR\CATCH\6
73	7500347	1	LATCH\IRBBR\MNT\6
74	7500590	1	ENCL\OPS\8-1/2X11X1-5/8
75	7500853	1	BRKT\EXTINGUISHER\20LB
76	8101600	2	SPNDL\2800
77	8101748	1	BRKT\STRGJACK
78	4100144	1	CYL\HYD\4X30\1-3/4 ROD\CLEVIS ENDS\O-RING PORTS
79	4100261	2	CYL\HYD\3X20\1-1/2ROD -CANADIAN TOOL & DIE
79A	4100328		CYL\HYD\3X20\1-1/2ROD -RAM INDUSTRIES
	NOT SHOWN		
	7501068	4	GRMTRBBR\3-5/8X3ID\3/8T

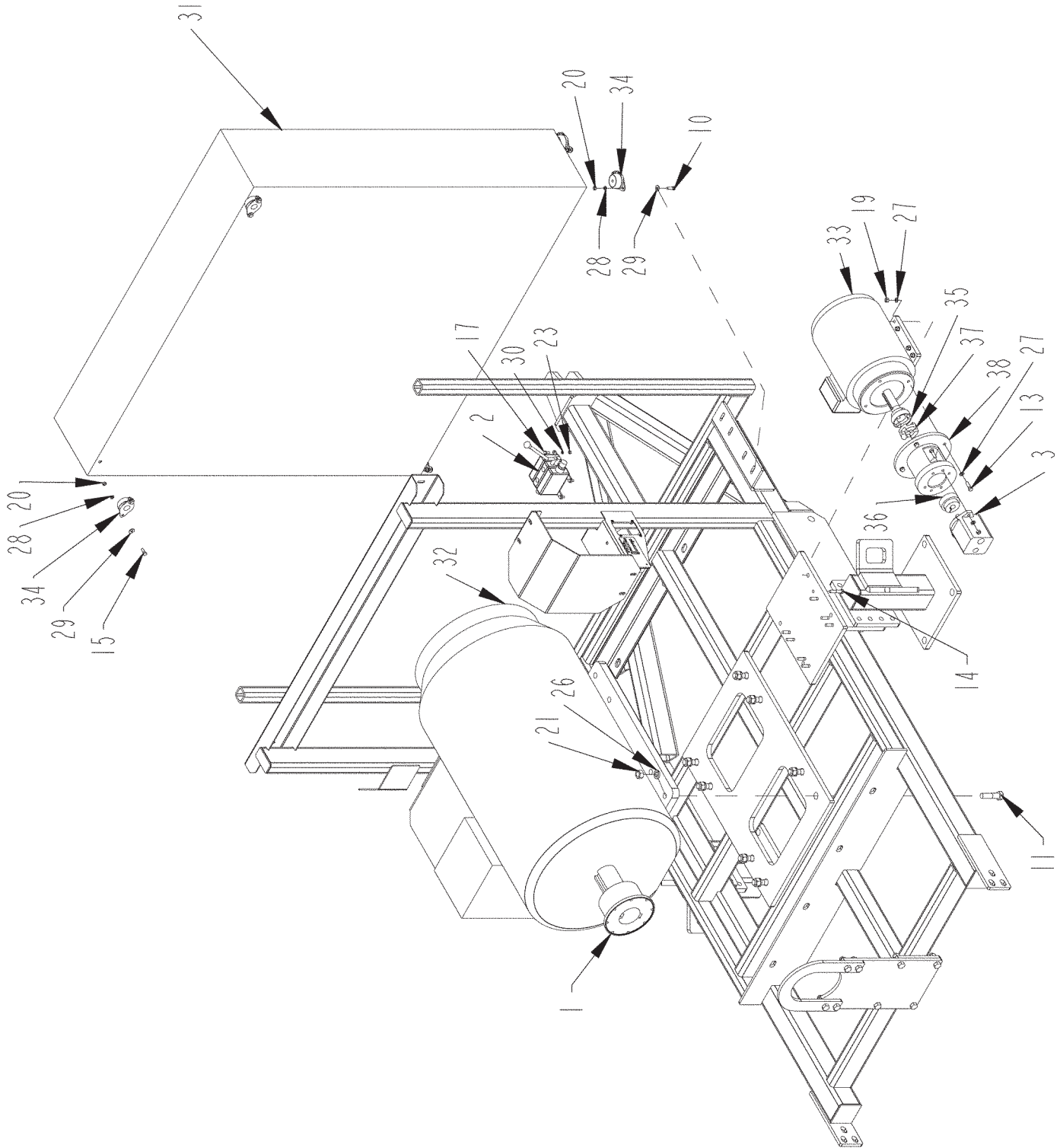
ELECTRIC MAINFRAME ASSEMBLY #3



**ELECTRIC MAINFRAME ASSEMBLY #3**

ITEM	PART	QTY.	PART DESCRIPTION
1	2600861	2	WHLASSY16.5SLX16.1X14PLY8BOLT-WHL16.1X14.3/8POS (SEE WHEEL AND HUB ASSEMBLY)
2	2900140	2	HUBIASSYH8178BOLT8"B.C.16"PILOT (SEE WHEEL AND HUB ASSEMBLY)
3	4000477	1	VALVEHYD2-BANKW/SWTCINORMOPEN
4	4100030	4	PIN 1" X 3-1/2" HYD. CYL.
5	4300088	1	SENSORIMAGW/HARDWARE
6	4501838	1	GUIDEISCRN
7	4502300	1	FRMMMAINH1100SS
8	4502336	1	DOORACCESSITNSNR
9	4502405	1	PLMNTPKPISPD
10	4502421	1	BRCKTMNTPKPISPD
11	4502430	1	BELTSEALTRNSTNCNVYR
12	4502439	1	ANGLCRSSFRRMID
13	4502614	1	PLTFRMMTRIELEC (THRU SN 0650)
14	4502615	4	PLISEALADJSHFTRTR
15	4502616	4	SEALSHAFT3-1/4IRTRNYLN
16	4502619	1	MNTMNFLDHOSEHYD
17	4502624	1	HITCHIELEC (THRU SN 0650)
18	4502625	2	STNDFRFRMELEC
19	4502626	2	CVRIFRIELEC
20	4502646	1	BRCKTMNTSWTCHLMT
21	4502647	1	CATCHARM/SWTCHLMT
22	4502648	1	PLATEFACESTATUSROTOR
23	4502649	1	CVRVLVTUB
24	4703579	1	HINGEASSYFAB3-1/2
25	4800003	26	BOLT HEX 3/8X1
26	4800010	8	BOLT HEX 5/8X2
27	4800018	4	BOLT HEX 1/2X1-1/4
28	4800033	6	BOLT HEX 3/4X2
29	4800034	4	BOLT HEX 3/8X1-1/2
30	4800046	1	PIN CLEVIS 3/4X3
31	4800079	8	BOLT HEX 5/8X2-1/2
32	4800082	10	BOLT HEX 1/2X1-1/2
33	4800085	1	BOLT HEX 1/2X1
34	4800098	4	BOLT HEX 3/8X1-1/4INC
35	4800107	1	PIN HAIR 1/8(#9)
36	4800140	2	BOLT HEX 1X3INC
37	4800142	2	BOLT HEX 3/8X1-3/4
38	4800164	8	BOLT HEX 3/8X3/4
39	4800178	2	BOLT HEX 1/2X1-3/4
40	4800203	8	PIN COT 5/32X2
41	4800277	8	BOLT HEX 1/4X1
42	4800283	6	BOLT HEX 3/4X2-1/4
43	4800496	4	SCRIPAN SLOT #10X3/4INC
44	4800546	2	BOLT HEX 1X5INC
45	4800588	4	SCRIRD SLOT #10-32X1/2
46	4800601	2	BOLT HEX 1X9INC
47	4900001	19	NUT HEX 1/2INC
48	4900002	20	NUT HEX 3/8INC
49	4900004	12	NUT HEX 3/4INC
50	4900005	16	NUT HEX 5/8INC
51	4900009	8	NUT HEX 1/4INC
52	4900015	2	NUT NYLCK 1INC
53	4900031	2	NUT HEX 1INC
54	4900072	4	NUT HEX #10INC
55	4900077	4	NUT HEX #10INF
56	4900082	9	NUT INSERT 3/8.027X.150GR
57	4900127	2	NUT PLCK 1INC
58	5000001	47	WASH FLAT 3/8
59	5000003	16	WASH LOCK 5/8
60	5000004	12	WASH FLAT 1/2
61	5000005	24	WASH FLAT 3/4
62	5000006	19	WASH LOCK 1/2
63	5000012	12	WASH LOCK 3/4
64	5000019	37	WASH LOCK 3/8
65	5000024	8	WASH LOCK 1/4
66	5000053	2	WASH LOCK 1
67	5000104	8	WASH LOCK #10
68	5700230	1	BOX CNTRL SAFETY SHUTDOWN
69	5700715	1	KIT LIGHT
70	5700716	1	KIT LIGHT
71	7500166	1	LATCH RB BR 6
72	7500190	1	LATCH RB BRICATCH 6
73	7500347	1	LATCH RB BR MNT 6
74	7500590	1	ENCL OPS 8-1/2X11X1-5/8
75	7500853	1	BRKT EXTINGUISHER 20LB
76	8101600	2	SPNDL 2800
77	8101748	1	BRKT STRG JACK
78	4100144	1	CYL HYD 4X30 1-3/4 ROD CLEVIS ENDS O-RING PORTS
79	4100261	2	CYL HYD 3X20 1-1/2 ROD -CANADIAN TOOL & DIE
79A	4100328		CYL HYD 3X20 1-1/2 ROD -RAM INDUSTRIES
	<b>NOT SHOWN</b>		
	7501068	4	GRMTRBBR 3-5/8X3DX3/8T

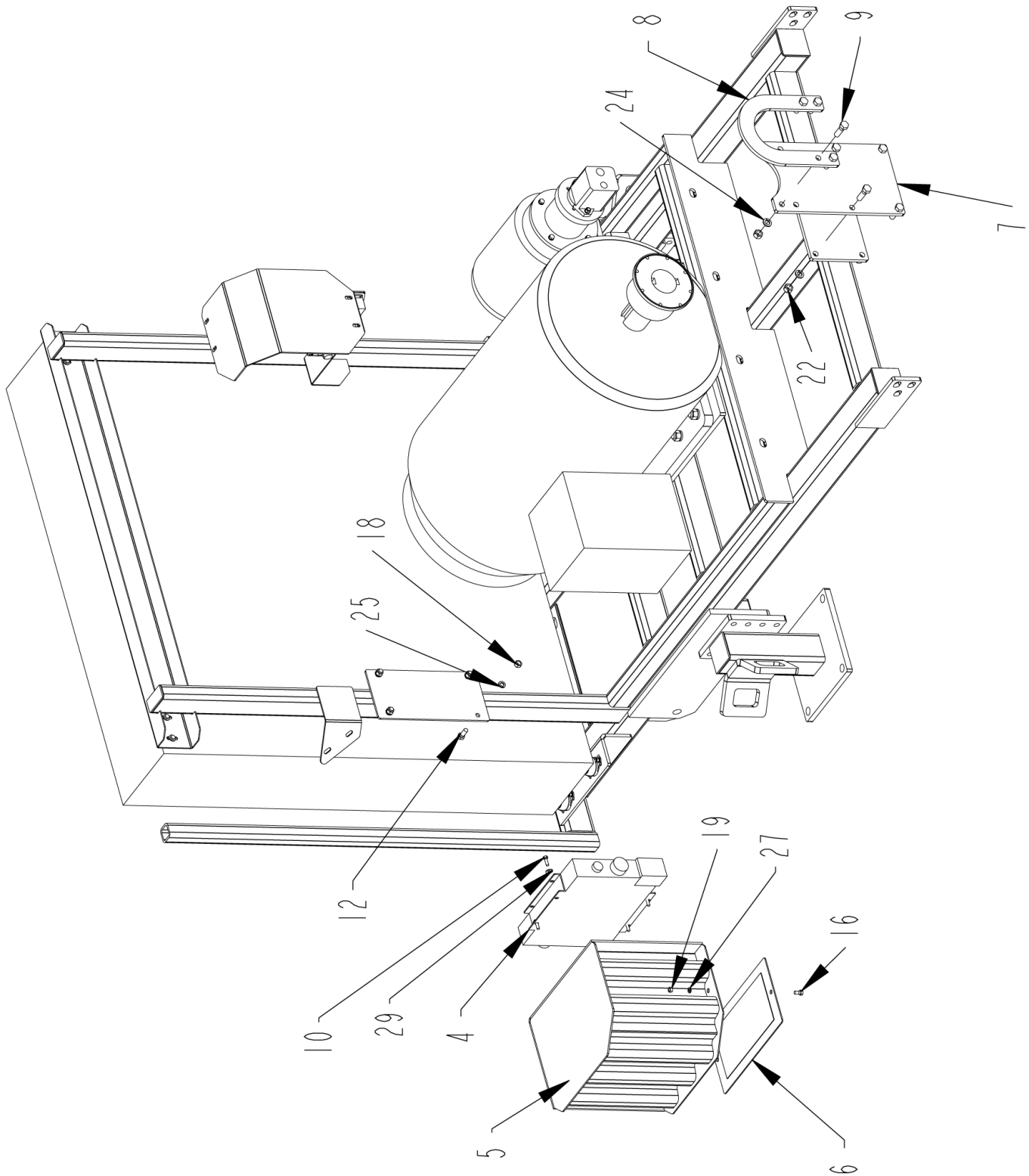
ELECTRIC MOTOR ASSEMBLY #1 (S.N. UP TO 0650)



**ELECTRIC MOTOR ASSEMBLY #1 (S.N. UP TO 0650)**

<b>ITEM</b>	<b>PART</b>	<b>QTY.</b>	<b>PART DESCRIPTION</b>
1	3600770	1	FLG\3-3/8IDX4L\1810\DRLIN
2	4000478	1	VALVE\HYD\1-BANK\W\NOSWITCH
3	4200124	1	PUMP\HYD\.89CID\CASAPPA
4	4200167	1	RAD\HYD\DCS16\12VDC\W\BYPASS
5	4502635	1	MNT\RAD\HYD
6	4502636	1	DR\SCRN\RAD
7	4502644	1	PL\STRP\DRVLN
8	4502645	1	STRP\DRVLN
9	4800010	8	BOLT\HEX\5/8X2
10	4800013	12	BOLT\HEX\5/16X1
11	4800017	8	BOLT\HEX\3/4X3
12	4800018	4	BOLT\HEX\1/2X1-1/4
13	4800098	6	BOLT\HEX\3/8X1-1/4\NC
14	4800146	8	BOLT\HEX\3/8X2
15	4800147	4	BOLT\HEX\5/16X7/8
16	4800164	2	BOLT\HEX\3/8X3/4
17	4800503	4	BOLT\HEX\1/4X5/8\NC
18	4900001	4	NUT\HEX\1/2\NC
19	4900002	12	NUT\HEX\3/8\NC
20	4900003	16	NUT\HEX\5/16\NC
21	4900004	8	NUT\HEX\3/4\NC
22	4900005	8	NUT\HEX\5/8\NC
23	4900009	4	NUT\HEX\1/4\NC
24	5000003	8	WASH\LOCK\5/8
25	5000006	4	WASH\LOCK\1/2
26	5000012	8	WASH\LOCK\3/4
27	5000019	16	WASH\LOCK\3/8
28	5000022	16	WASH\LOCK\5/16
29	5000023	20	WASH\FLAT\5/16
30	5000024	4	WASH\LOCK\1/4
31	5700945	1	PKG\STRTR\380-480V\50/60HZ\4PL <b>(USED IN THE 460V @60HZ, 380V @50HZ &amp; 380V @60HZ)</b>
31A	5700949	1	PKG\STRTR\575V\60HZ\30HP\4PL <b>(USED IN THE 575V @60HZ)</b>
32	5700946	1	MTR\ELEC\300HP\460\60HZ\4PL <b>(USED IN THE 460V @60HZ)</b>
32A	5700951	1	MTR\ELEC\300HP\380V\50HZ\4PL <b>(USED IN THE 380V @50HZ)</b>
32B	5700974	1	MTR\ELEC\300HP\380V\60HZ\4PL <b>(USED IN THE 380V @60HZ)</b>
32C	5700950	1	MTR\ELEC\300HP\575V\60HZ\4PL <b>(USED IN THE 575V @60HZ)</b>
33	5700947	1	MTR\ELEC\10HP\460\60HZ\215TC <b>(USED IN THE 460V @60HZ &amp; 575V @60HZ)</b>
33A	5700952	1	MTR\ELEC\10HP\380V\4PL\254TC <b>(USED IN THE 380V @50HZ &amp; 380V @60HZ)</b>
34	7501391	6	CUSH\RBBR\3-3/4X2-1/4X1-1/4\3/8UNC
35	7501449	1	CPLNG\200SERIES\1-3/8\5/16"KW <b>(USED IN THE 460V @60HZ &amp; 575V @60HZ)</b>
35A	7501469	1	CPLNG\300SERIES\1-5/8"X3/8"KW <b>(USED IN THE 380V @50HZ &amp; 380V @60HZ)</b>
36	7501450	1	CPLNG\200SERIES\7/8\13TOOTH <b>(USED IN THE 460V @60HZ &amp; 575V @60HZ)</b>
36A	7501470	1	CPLNG\300SERIES\7/8\13TOOTH <b>(USED IN THE 380V @50HZ &amp; 380V @60HZ)</b>
37	7501451	1	CPLNG\200SERIES\INSERT\URETH <b>(USED IN THE 460V @60HZ &amp; 575V @60HZ)</b>
37A	7501471	1	CPLNG\300SERIES\INSERT\URETH <b>(USED IN THE 380V @50HZ &amp; 380V @60HZ)</b>
38	7501452	1	CPLNG\PUMP\MTR\ELEC\182-256TC <b>(USED IN THE 460V @60HZ &amp; 575V @60HZ)</b>
38A	7501468	1	CPLNG\PUMP\MTR\ELEC\254TC <b>(USED IN THE 380V @50HZ &amp; 380V @60HZ)</b>
<b>NOT SHOWN</b>			
	3600771	1	DRLIN\IND\1810\29-1/16COMP
	5700897	1	SENSOR\TEMP

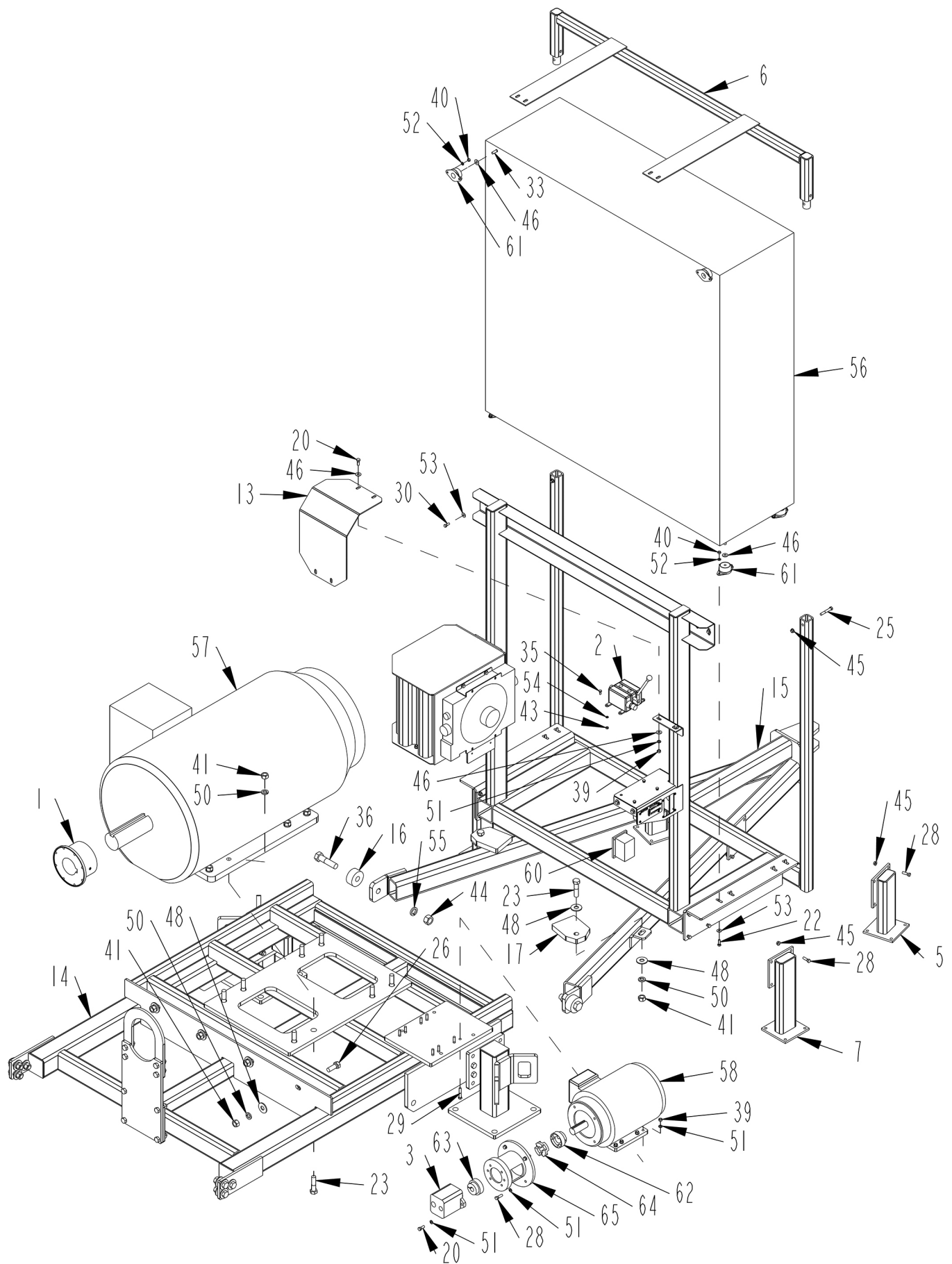
ELECTRIC MOTOR ASSEMBLY #2 (S.N. UP TO 0650)



**ELECTRIC MOTOR ASSEMBLY #2 (S.N. UP TO 0650)**

<b>ITEM</b>	<b>PART</b>	<b>QTY.</b>	<b>PART DESCRIPTION</b>
1	3600770	1	FLG\3-3/8IDX4L\1810\DRLIN
2	4000478	1	VALVE\HYD\1-BANK\W/NOSWITCH
3	4200124	1	PUMP\HYD\89CID\CASAPPA
4	4200167	1	RAD\HYD\DCS16\12VDC\W/BYPASS
5	4502635	1	MNT\RAD\HYD
6	4502636	1	DR\SCRN\RAD
7	4502644	1	PL\STRP\DRVLN
8	4502645	1	STRP\DRVLN
9	4800010	8	BOLT\HEX\5/8X2
10	4800013	12	BOLT\HEX\5/16X1
11	4800017	8	BOLT\HEX\3/4X3
12	4800018	4	BOLT\HEX\1/2X1-1/4
13	4800098	6	BOLT\HEX\3/8X1-1/4\NC
14	4800146	8	BOLT\HEX\3/8X2
15	4800147	4	BOLT\HEX\5/16X7/8
16	4800164	2	BOLT\HEX\3/8X3/4
17	4800503	4	BOLT\HEX\1/4X5/8\NC
18	4900001	4	NUT\HEX\1/2\NC
19	4900002	12	NUT\HEX\3/8\NC
20	4900003	16	NUT\HEX\5/16\NC
21	4900004	8	NUT\HEX\3/4\NC
22	4900005	8	NUT\HEX\5/8\NC
23	4900009	4	NUT\HEX\1/4\NC
24	5000003	8	WASH\LOCK\5/8
25	5000006	4	WASH\LOCK\1/2
26	5000012	8	WASH\LOCK\3/4
27	5000019	16	WASH\LOCK\3/8
28	5000022	16	WASH\LOCK\5/16
29	5000023	20	WASH\FLAT\5/16
30	5000024	4	WASH\LOCK\1/4
31	5700945	1	PKG\STRTR\380-480V\50/60HZ\4PL <b>(USED IN THE 460V @60HZ, 380V @50HZ &amp; 380V @60HZ)</b>
31A	5700949	1	PKG\STRTR\575V\60HZ\30HP\4PL <b>(USED IN THE 575V @60HZ)</b>
32	5700946	1	MTR\ELEC\300HP\460\60HZ\4PL <b>(USED IN THE 460V @60HZ)</b>
32A	5700951	1	MTR\ELEC\300HP\380V\50HZ\4PL <b>(USED IN THE 380V @50HZ)</b>
32B	5700974	1	MTR\ELEC\300HP\380V\60HZ\4PL <b>(USED IN THE 380V @60HZ)</b>
32C	5700950	1	MTR\ELEC\300HP\575V\60HZ\4PL <b>(USED IN THE 575V @60HZ)</b>
33	5700947	1	MTR\ELEC\10HP\460\60HZ\215TC <b>(USED IN THE 460V @60HZ &amp; 575V @60HZ)</b>
33A	5700952	1	MTR\ELEC\10HP\380V\4PL\254TC <b>(USED IN THE 380V @50HZ &amp; 380V @60HZ)</b>
34	7501391	6	CUSH\RBBR\3-3/4X2-1/4X1-1/4\3/8UNC
35	7501449	1	CPLNG\200SERIES\1-3/8\5/16"KW <b>(USED IN THE 460V @60HZ &amp; 575V @60HZ)</b>
35A	7501469	1	CPLNG\300SERIES\1-5/8"X3/8"KW <b>(USED IN THE 380V @50HZ &amp; 380V @60HZ)</b>
36	7501450	1	CPLNG\200SERIES\7/8\13TOOTH <b>(USED IN THE 460V @60HZ &amp; 575V @60HZ)</b>
36A	7501470	1	CPLNG\300SERIES\7/8\13TOOTH <b>(USED IN THE 380V @50HZ &amp; 380V @60HZ)</b>
37	7501451	1	CPLNG\200SERIES\INSERT\URETH <b>(USED IN THE 460V @60HZ &amp; 575V @60HZ)</b>
37A	7501471	1	CPLNG\300SERIES\INSERT\URETH <b>(USED IN THE 380V @50HZ &amp; 380V @60HZ)</b>
38	7501452	1	CPLNG\PUMP\MTR\ELEC\182-256TC <b>(USED IN THE 460V @60HZ &amp; 575V @60HZ)</b>
38A	7501468	1	CPLNG\PUMP\MTR\ELEC\254TC <b>(USED IN THE 380V @50HZ &amp; 380V @60HZ)</b>
<b>NOT SHOWN</b>			
	3600771	1	DRLIN\IND\1810\29-1/16COMP
	5700897	1	SENSOR\TEMP

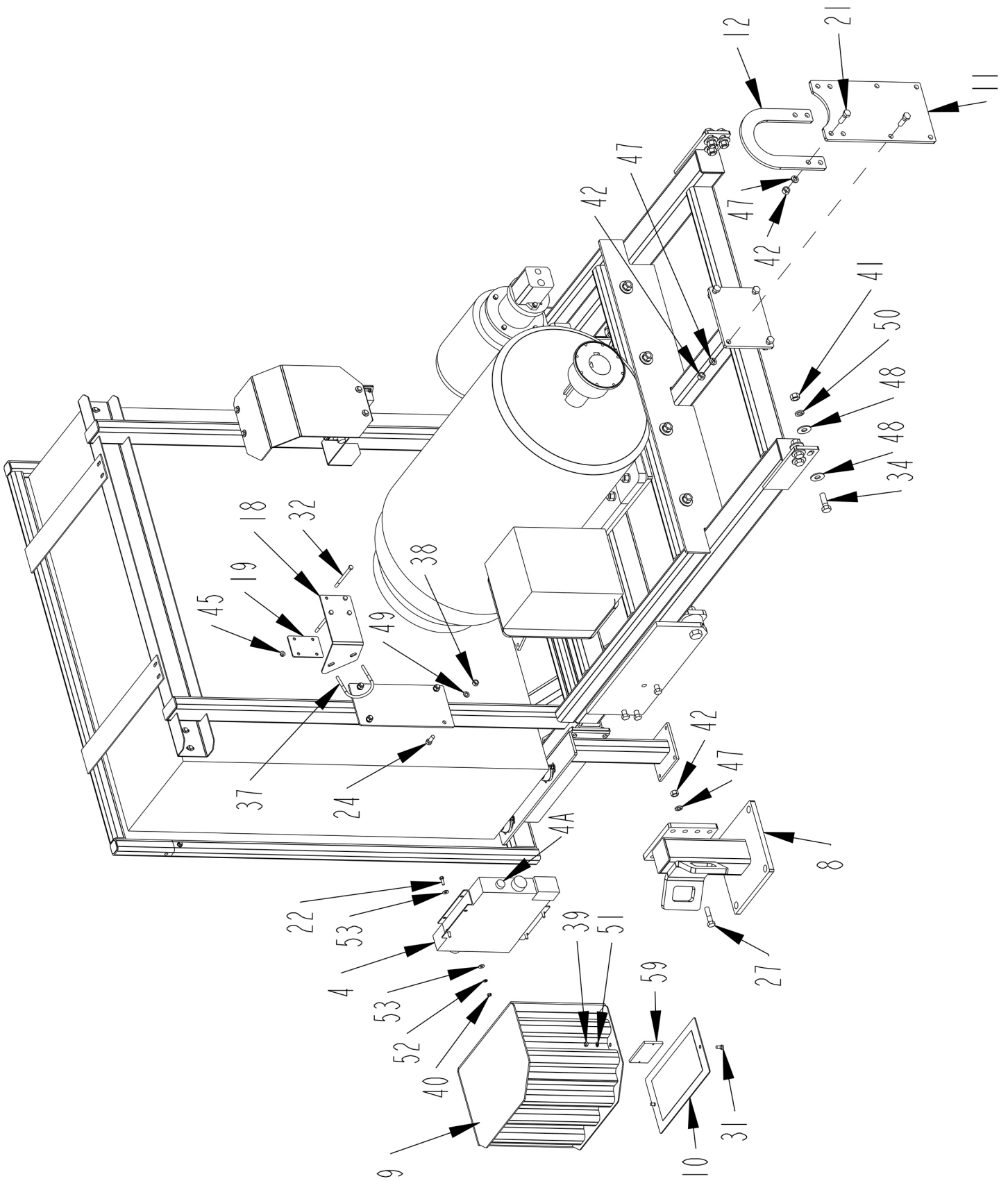
**ELECTRIC MOTOR ASSEMBLY #1 (S.N. 0651 & UP)**



**ELECTRIC MOTOR ASSEMBLY #1 (S.N. 0651 & UP)**

ITEM	PART	QTY.	PART DESCRIPTION
1	3600770	1	FLG\3-3/8\IDX4L\1810\DRLIN
2	4000478	1	VALVE\HYD\1-BANK\W\NOSWITCH
3	4200124	1	PUMP\HYD\1.89CID\CASAPPA
4	4200167	1	RAD\HYD\IDCS16\12VDC\W\BYPASS
4A	5700897	1	SENSOR\TEMP
5	4501697	2	JACKSTAND\H1130EL\12
6	4501698	1	GUARD\TOP\ISOFTSTART\H1130EL
7	4501699	2	JACKSTAND\H1130EL\16
8	4502625	2	STND\FR\FRM\ELEC
9	4502635	1	MNT\RAD\HYD
10	4502636	1	DR\SCRN\RAD
11	4502644	1	PL\STRP\DRV\LN
12	4502645	1	STRP\DRV\LN
13	4502649	1	CVR\VLV\TUB
14	4502844	1	PLTFR\MTR\ELEC
15	4502845	1	HITCH\ELEC
16	4502849	2	SPCR\MNT\HTCH\ELEC (FOR TRANSPORT)
17	4502901	2	PL\SPCR\HITCH\1130EL
18	4502903	1	SHMNT\CONDUIT
19	4502904	1	SHMNT\CONDUIT
20	4800003	6	BOLT\HEX\3/8X1
21	4800010	8	BOLT\HEX\5/8X2
22	4800013	12	BOLT\HEX\5/16X1
23	4800017	10	BOLT\HEX\3/4X3
24	4800018	4	BOLT\HEX\1/2X1-1/4
25	4800029	2	BOLT\HEX\3/8X2-1/2
26	4800033	4	BOLT\HEX\3/4X2
27	4800079	8	BOLT\HEX\5/8X2-1/2
28	4800098	20	BOLT\HEX\3/8X1-1/4\NC
29	4800146	8	BOLT\HEX\3/8X2
30	4800147	4	BOLT\HEX\5/16X7/8
31	4800164	2	BOLT\HEX\3/8X3/4
32	4800202	4	BOLT\HEX\3/8X5
33	4800276	6	BOLT\HEX\3/8X1-1/4\NF
34	4800283	6	BOLT\HEX\3/4X2-1/4
35	4800503	4	BOLT\HEX\1/4X5/8\NC
36	4800647	2	BOLT\HEX\1X4\NC
37	4801222	1	BOLT\U\3/8X4X5-1/2
38	4900001	4	NUT\HEX\1/2\NC
39	4900002	14	NUT\HEX\3/8\NC
40	4900003	16	NUT\HEX\5/16\NC
41	4900004	20	NUT\HEX\3/4\NC
42	4900005	16	NUT\HEX\5/8\NC
43	4900009	4	NUT\HEX\1/4\NC
44	4900031	2	NUT\HEX\1\NC
45	4900076	22	NUT\FLG\SERR\3/8\NC
46	5000001	14	WASH\FLAT\3/8
47	5000003	16	WASH\LOCK\5/8
48	5000005	24	WASH\FLAT\3/4
49	5000006	4	WASH\LOCK\1/2
50	5000012	20	WASH\LOCK\3/4
51	5000019	20	WASH\LOCK\3/8
52	5000022	16	WASH\LOCK\5/16
53	5000023	20	WASH\FLAT\5/16
54	5000024	4	WASH\LOCK\1/4
55	5000053	2	WASH\LOCK\1
56	5700945	1	PKG\STRTR\380-480V\50/60HZ\4PL (USED IN THE 460V @60HZ, 380V @50HZ & 380V @60HZ)
56A	5700949	1	PKG\STRTR\575V\60HZ\30HP\4PL (USED IN THE 575V @60HZ)
57	5700946	1	MTR\ELEC\300HP\460\60HZ\4PL (USED IN THE 460V @60HZ)
57A	5700951	1	MTR\ELEC\300HP\380V\50HZ\4PL (USED IN THE 380V @50HZ)
57B	5700974	1	MTR\ELEC\300HP\380V\60HZ\4PL (USED IN THE 380V @60HZ)
57C	5700950	1	MTR\ELEC\300HP\575V\60HZ\4PL (USED IN THE 575V @60HZ)
58	5700947	1	MTR\ELEC\10HP\460\60HZ\2\125TC (USED IN THE 460V @60HZ & 575V @60HZ)
58A	5700952	1	MTR\ELEC\10HP\380V\4PL\254TC (USED IN THE 380V @50HZ & 380V @60HZ)
59	5700955	1	CNTRL\FAN\SNGL\12&24V
60	5700966	1	ENCL\RELAY\FUSE\ISO280TERMINALS
61	7501391	6	CUSH\RB\BR\3-3/4X2-1/4X1-1/4\3/8UNC
62	7501449	1	CPLNG\200SERIES\1-3/8"5/16"KW (USED IN THE 460V @60HZ & 575V @60HZ)
62A	7501469	1	CPLNG\300SERIES\1-5/8"X3/8"KW (USED IN THE 380V @50HZ & 380V @60HZ)
63	7501450	1	CPLNG\200SERIES\7/8\13TOOTH (USED IN THE 460V @60HZ & 575V @60HZ)
63A	7501470	1	CPLNG\300SERIES\7/8\13TOOTH (USED IN THE 380V @50HZ & 380V @60HZ)
64	7501451	1	CPLNG\200SERIES\INSERT\URETH (USED IN THE 460V @60HZ & 575V @60HZ)
64A	7501471	1	CPLNG\300SERIES\INSERT\URETH (USED IN THE 380V @50HZ & 380V @60HZ)
65	7501452	1	CPLNG\PUMP\MTR\ELEC\182-256TC (USED IN THE 460V @60HZ & 575V @60HZ)
65A	7501468	1	CPLNG\PUMP\MTR\ELEC\254TC (USED IN THE 380V @50HZ & 380V @60HZ)
	<b>NOT SHOWN</b>		
	3600771	1	DRLIN\IND\1810\29-1/16COMP

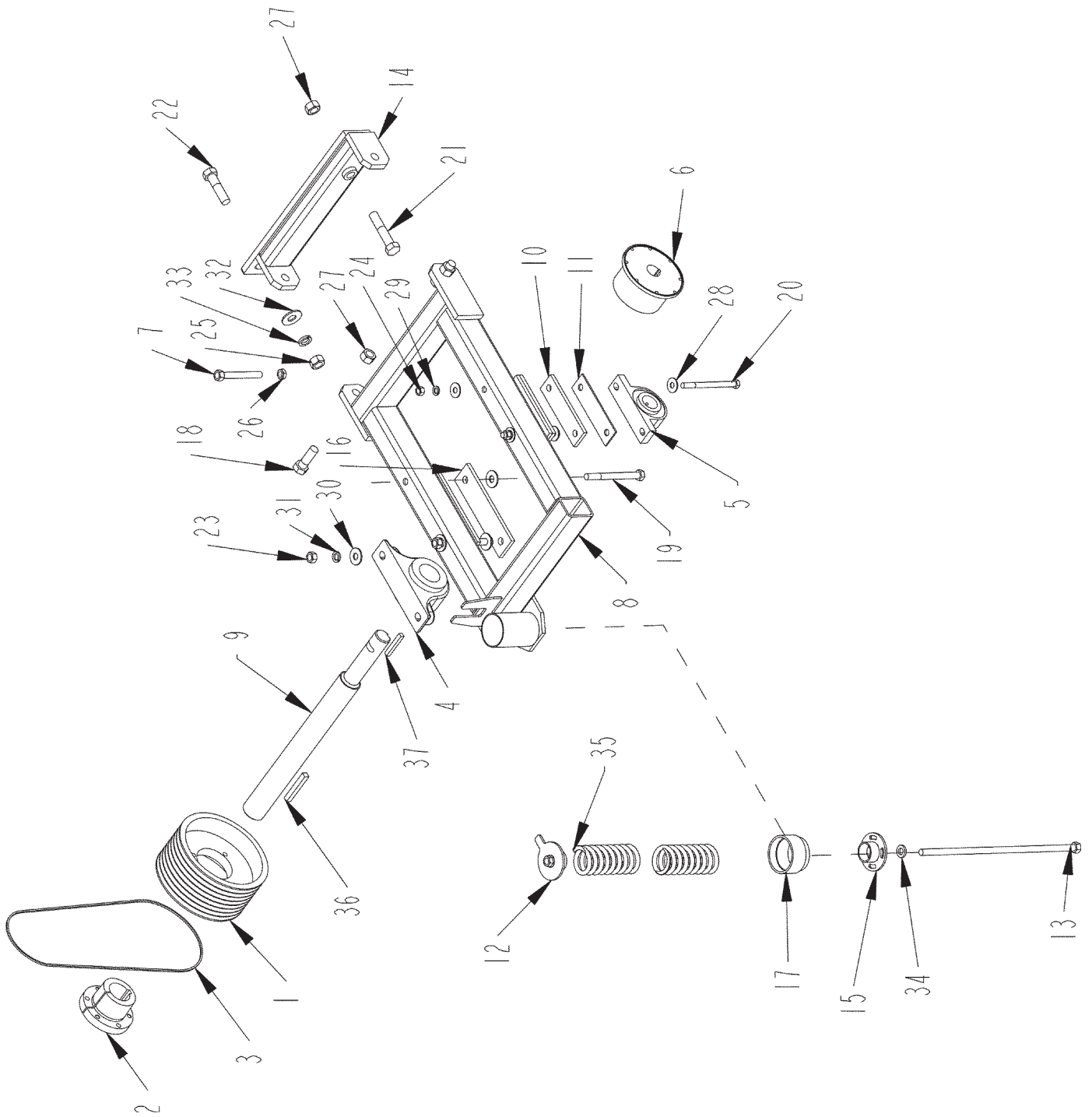
ELECTRIC MOTOR ASSEMBLY #2 (S.N. 0651 & UP)



**ELECTRIC MOTOR ASSEMBLY #2 (S.N. 0651 & UP)**

ITEM	PART	QTY.	PART DESCRIPTION
1	3600770	1	FLG\3-8\8\DX4L\1810\DRLIN
2	4000478	1	VALVE\HYD\1-BANK\W\NOSWITCH
3	4200124	1	PUMP\HYD\1.89CID\CASAPPA
4	4200167	1	RAD\HYD\DCS\16\12VDC\W\BYPASS
4A	5700897	1	SENSOR\TEMP
5	4501697	2	JACKSTAND\H1130EL\12
6	4501698	1	GUARD\TOP\ISOFTSTART\H1130EL
7	4501699	2	JACKSTAND\H1130EL\16
8	4502625	2	STND\FRM\TRIELEC
9	4502635	1	MNT\RAD\HYD
10	4502636	1	DR\SCR\IRAD
11	4502644	1	PL\STRP\DRVLN
12	4502645	1	STRP\DRVLN
13	4502649	1	CVR\VLV\TUB
14	4502844	1	PL\FRM\MTRIELEC
15	4502845	1	HITCHIELEC
16	4502849	2	SPCR\MNT\HITCHIELEC (FOR TRANSPORT)
17	4502901	2	PL\SPCR\HITCH\1130EL
18	4502903	1	SHM\MT\CONDUIT
19	4502904	1	SHM\MT\CONDUIT
20	4800003	6	BOLT\HEX\1/3\8X1
21	4800010	8	BOLT\HEX\1/5\8X2
22	4800013	12	BOLT\HEX\1/5\16X1
23	4800017	10	BOLT\HEX\1/3\4X3
24	4800018	4	BOLT\HEX\1/2X1-1/4
25	4800029	2	BOLT\HEX\1/3\8X2-1/2
26	4800033	4	BOLT\HEX\1/3\4X2
27	4800079	8	BOLT\HEX\1/5\8X2-1/2
28	4800098	20	BOLT\HEX\1/3\8X1-1/4\NC
29	4800146	8	BOLT\HEX\1/3\8X2
30	4800147	4	BOLT\HEX\1/5\16X7/8
31	4800164	2	BOLT\HEX\1/3\8X3/4
32	4800202	4	BOLT\HEX\1/3\8X5
33	4800276	6	BOLT\HEX\1/3\8X1-1/4\NF
34	4800283	6	BOLT\HEX\1/3\4X2-1/4
35	4800503	4	BOLT\HEX\1/4X5/8\NC
36	4800647	2	BOLT\HEX\1X4\NC
37	4801222	1	BOLT\U\3\8X4X5-1/2
38	4900001	4	NUT\HEX\1/2\NC
39	4900002	14	NUT\HEX\1/3\8\NC
40	4900003	16	NUT\HEX\1/5\16\NC
41	4900004	20	NUT\HEX\1/3\4\NC
42	4900005	16	NUT\HEX\1/5\8\NC
43	4900009	4	NUT\HEX\1/4\NC
44	4900031	2	NUT\HEX\1\NC
45	4900076	22	NUT\FLG\SERR\1/3\8\NC
46	5000001	14	WASH\FLAT\3/8
47	5000003	16	WASH\LOCK\1/5/8
48	5000005	24	WASH\FLAT\3/4
49	5000006	4	WASH\LOCK\1/2
50	5000012	20	WASH\LOCK\1/3/4
51	5000019	20	WASH\LOCK\1/3/8
52	5000022	16	WASH\LOCK\1/5/16
53	5000023	20	WASH\FLAT\5/16
54	5000024	4	WASH\LOCK\1/4
55	5000053	2	WASH\LOCK\1
56	5700945	1	PKG\STRTR\1380-480V\50\60HZ\4PL (USED IN THE 460V @60HZ, 380V @50HZ & 380V @60HZ)
56A	5700949	1	PKG\STRTR\1575V\60HZ\30HP\4PL (USED IN THE 575V @60HZ)
57	5700946	1	MTRIELEC\300HP\460\60HZ\4PL (USED IN THE 460V @60HZ)
57A	5700951	1	MTRIELEC\300HP\380V\50HZ\4PL (USED IN THE 380V @50HZ)
57B	5700974	1	MTRIELEC\300HP\380V\60HZ\4PL (USED IN THE 380V @60HZ)
57C	5700950	1	MTRIELEC\300HP\575V\60HZ\4PL (USED IN THE 575V @60HZ)
58	5700947	1	MTRIELEC\10HP\460\60HZ\2\15TC (USED IN THE 460V @60HZ & 575V @60HZ)
58A	5700952	1	MTRIELEC\10HP\380V\4PL\254TC (USED IN THE 380V @50HZ & 380V @60HZ)
59	5700955	1	CNTRL\FAN\SNGL\12&24V
60	5700966	1	ENCL\RELAY\FUSE\ISO280TERMINALS
61	7501391	6	CUSH\RB\BR\3-3/4X2-1/4X1-1/4\3/8UNC
62	7501449	1	CPLNG\200SERIES\1-3/8"5/16"KW (USED IN THE 460V @60HZ & 575V @60HZ)
62A	7501469	1	CPLNG\300SERIES\1-5/8"X3/8"KW (USED IN THE 380V @50HZ & 380V @60HZ)
63	7501450	1	CPLNG\200SERIES\7/8\13TOOTH (USED IN THE 460V @60HZ & 575V @60HZ)
63A	7501470	1	CPLNG\300SERIES\7/8\13TOOTH (USED IN THE 380V @50HZ & 380V @60HZ)
64	7501451	1	CPLNG\200SERIES\INSERT\URETH (USED IN THE 460V @60HZ & 575V @60HZ)
64A	7501471	1	CPLNG\300SERIES\INSERT\URETH (USED IN THE 380V @50HZ & 380V @60HZ)
65	7501452	1	CPLNG\PUMP\MTRIELEC\182-256TC (USED IN THE 460V @60HZ & 575V @60HZ)
65A	7501468	1	CPLNG\PUMP\MTRIELEC\254TC (USED IN THE 380V @50HZ & 380V @60HZ)
	<b>NOT SHOWN</b>		
	3600771	1	DRLIN\IND\1810\29-1/16COMP

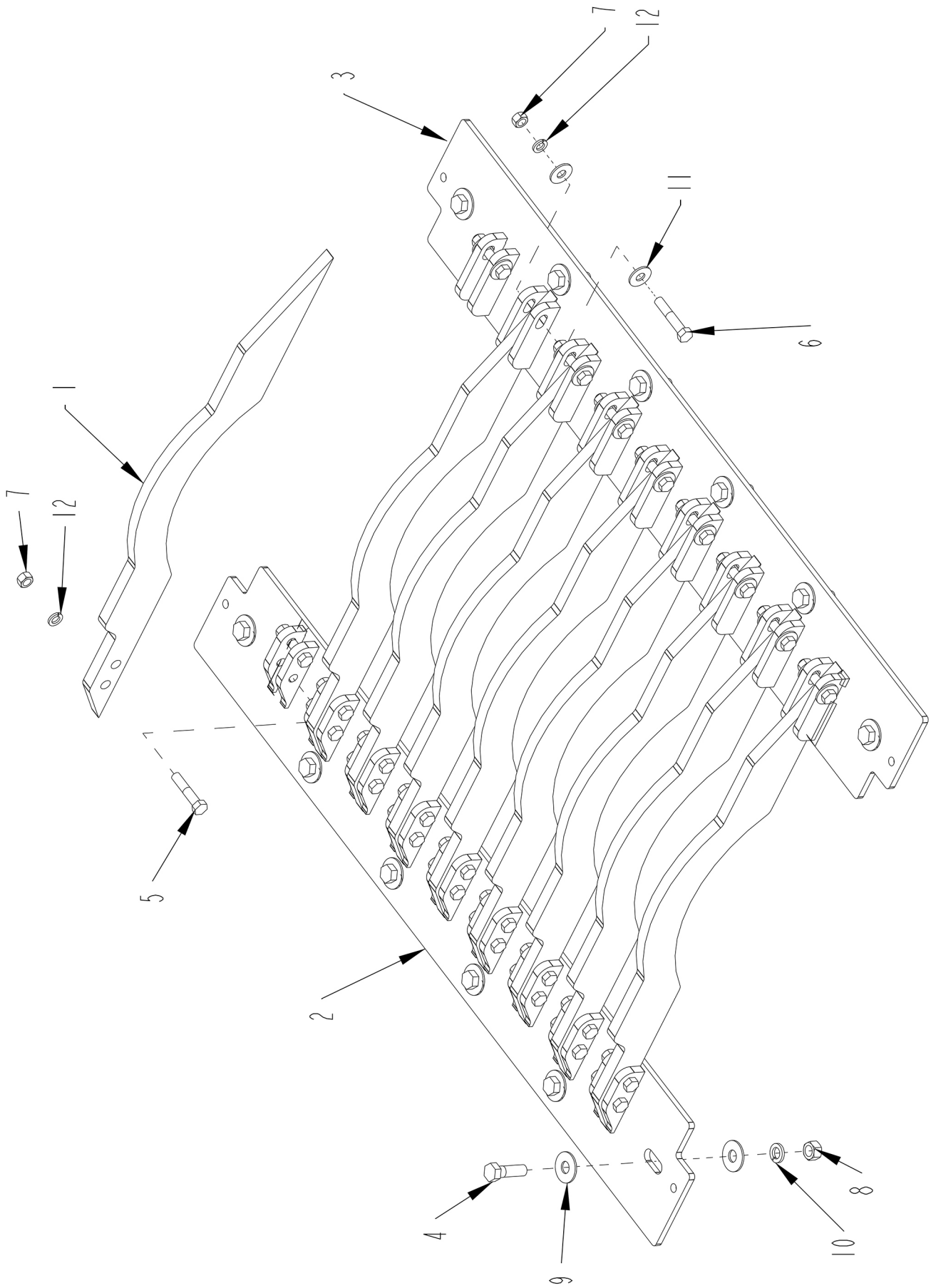
# OFFSET BULL WHEEL



**OFFSET BULL WHEEL**

<b>ITEM</b>	<b>PART</b>	<b>QTY.</b>	<b>PART DESCRIPTION</b>
1	1400656	1	SHVE\5V-8\11.8\85V180F
2	1400657	1	BUSH\QD\F\2-3/4
3	1600104	2	V-BELT\4\5VP710
4	2000509	1	BRG\PB\2-3/4\E\DODGE
5	2000510	1	BRG\PB\2\2BOLT
6	3600769	1	FLG\2IDX3-1/2L\1810\DRVLN
7	4501170	1	BOLT\FRM\TGHTNR\CHAIN\TUB
8	4502330	1	WHL\BULL\FRM\OFFSET
9	4502331	1	SHFT\WHL\BULL\OFFSET
10	4502333	3	SHIM\BRG\WHL\BULL
11	4502334	1	SHM\THN\BRG\WHL\BLL
12	4502338	1	CAP\SPRNG\TNSNR
13	4502340	1	ROD\TNSNR\WHL\BULL
14	4502419	1	ADJ\WHL\BLL
15	4502425	1	CAP\TNSNR\WHL\BLL
16	4502622	2	SHIM\BRG\WHL\BULL\1/2"
17	4502623	1	INSERT\SPRNG\WHL\BULL
18	4800140	2	BOLT\HEX\1X3\NC
19	4800232	2	BOLT\HEX\3/4X8
20	4800236	2	BOLT\HEX\5/8X8
21	4800546	1	BOLT\HEX\1X5\NC
22	4800647	1	BOLT\HEX\1X4\NC
23	4900004	4	NUT\HEX\3/4\NC
24	4900005	2	NUT\HEX\5/8\NC
25	4900031	1	NUT\HEX\1\NC
26	4900104	1	NUT\JAM\3/4\NC
27	4900127	3	NUT\TPLCK\1\NC
28	5000002	4	WASH\FLAT\5/8
29	5000003	2	WASH\LOCK\5/8
30	5000005	4	WASH\FLAT\3/4
31	5000012	2	WASH\LOCK\3/4
32	5000014	1	WASH\FLAT\1
33	5000053	1	WASH\LOCK\1
34	5000115	1	WASH\FLAT\3/4\EXTRTHK\GR8
35	6100091	2	SPG\COMP\8X3-1/2OD\1/2WD
36	6200013	1	KEY\SQ\5/8X4-1/2
37	6200062	1	KEY\SQ\1/2X3-1/2
	<b>4502607</b>		<b>WHL\BULL\OFFSET\ELECTRIC&gt;</b>
	<b>NOT SHOWN</b>		
	4800958	2	SCR\SET\ALN\1/2X3/4\NC
	4801253	8	SCR\CAP\ALN\5/8X4\NF

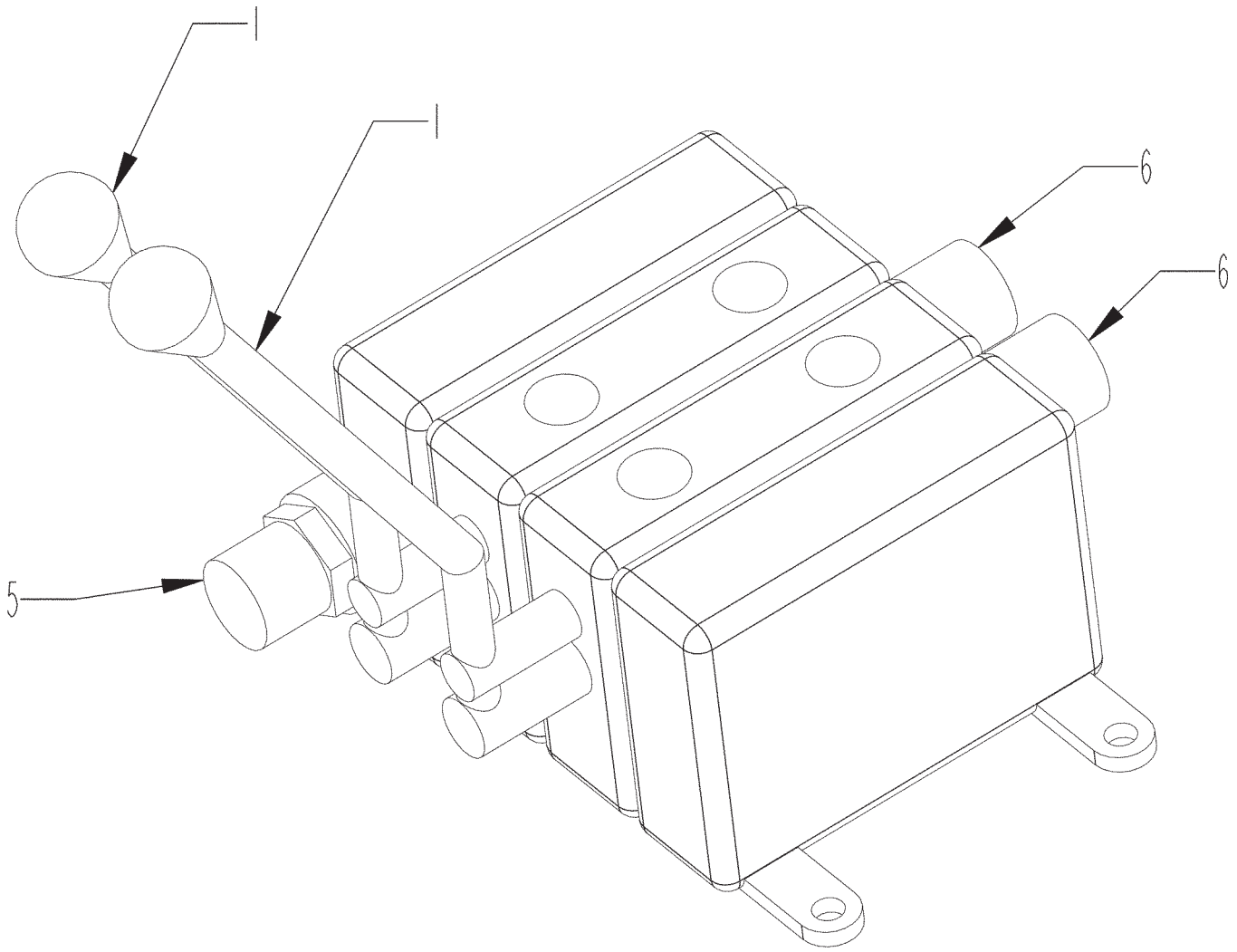
MILL GRATE - 9 BAR - 3"



**MILL GRATE - 9 BAR - 3"**

<b>ITEM</b>	<b>PART</b>	<b>QTY.</b>	<b>PART DESCRIPTION</b>
1	4502679	9	BAR\GRATE\MILL\RAISED\9BAR
2	4502832	1	PL\SIDE\GRATE\MILL
3	4502834	1	PL\SIDE\GRATE\MILL\RAISED\9 BAR
4	4800010	12	BOLT\HEX\5/8X2
5	4800070	18	BOLT\HEX\1/2X2-1/2
6	4800351	9	BOLT\HEX\1/2X2-3/4
7	4900001	27	NUT\HEX\1/2\NC
8	4900005	12	NUT\HEX\5/8\NC
9	5000002	24	WASH\FLAT\5/8
10	5000003	12	WASH\LOCK\5/8
11	5000004	18	WASH\FLAT\1/2
12	5000006	27	WASH\LOCK\1/2
	<b>4502285</b>		<b>GRATE\MILL\9BAR\3\ASSY</b>

400477 - 2 BANK HYDRAULIC VALVE



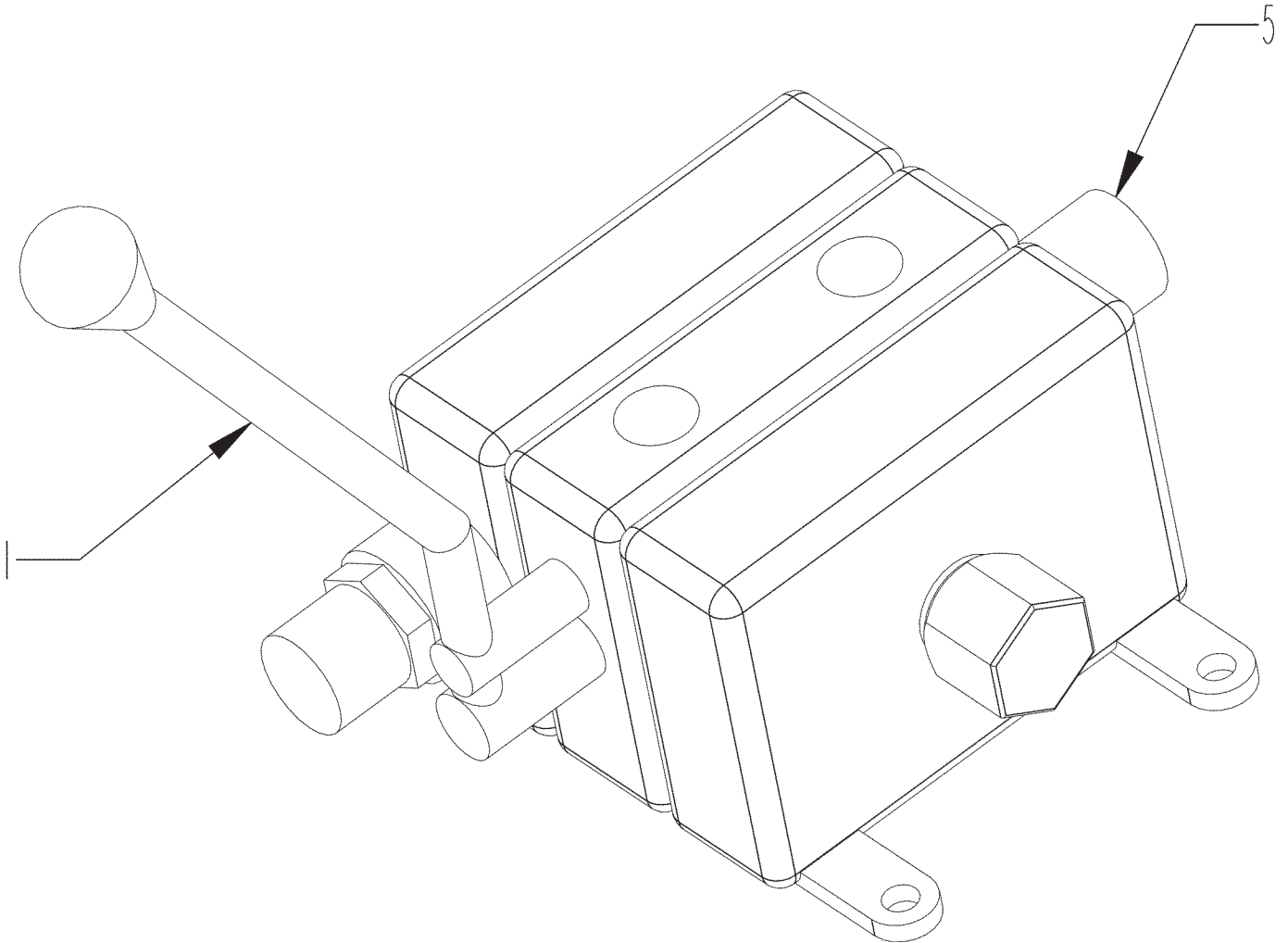
**400477 - 2 BANK HYDRAULIC VALVE**

<b>ITEM</b>	<b>PART</b>	<b>QTY.</b>	<b>PART DESCRIPTION</b>
1	4000472	2	HANDLE\KIT\VLV\HYD\34SERIES
2	4000473	2	KIT\LOCK\LOAD
3	4000498	2	KIT\SEAL\SPOOL\W\LOAD LOCKS
4	4000499	1	KIT\SEAL\SECTION\34SERIES
5	4000500	1	CRTRG\RELEIF\VLV\34SER\2500
6	5700905	2	SWITCH\VALVE\HYD

**NOT SHOWN**

4000537	VALVE\HYD\REPLACE\LOAD;LOCK\STEEL
4000538	VALVE\HYD\CART\LOAD;LOCK\STEEL

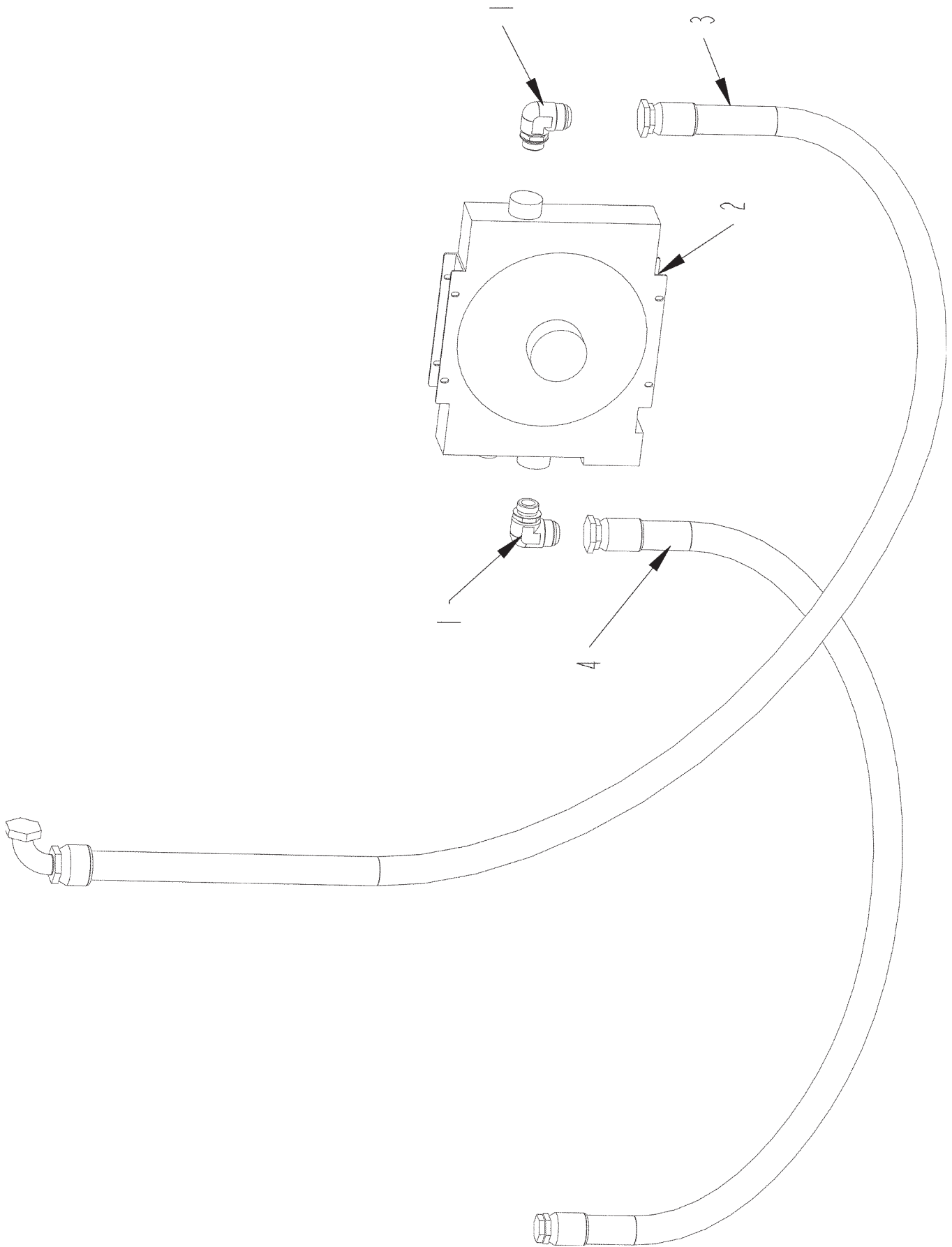
400478 - 1 BANK HYDRAULIC VALVE



**400478 - 1 BANK HYDRAULIC VALVE**

<b>ITEM</b>	<b>PART</b>	<b>QTY.</b>	<b>PART DESCRIPTION</b>
1	4000472	1	HANDLE\KIT\VLV\HYD\34SERIES
2	4000473	1	KIT\LOCK\LOAD
3	4000498	1	KIT\SEAL\SPOOL\W\LOAD LOCKS
4	4000499	1	KIT\SEAL\SECTION\34SERIES
5	5700905	1	SWITCH\VALVE\HYD
	<b>NOT SHOWN</b>		
	4000537		VALVE\HYD\REPLACE\LOAD;LOCK\STEEL
	4000538		VALVE\HYD\CART\LOAD;LOCK\STEEL

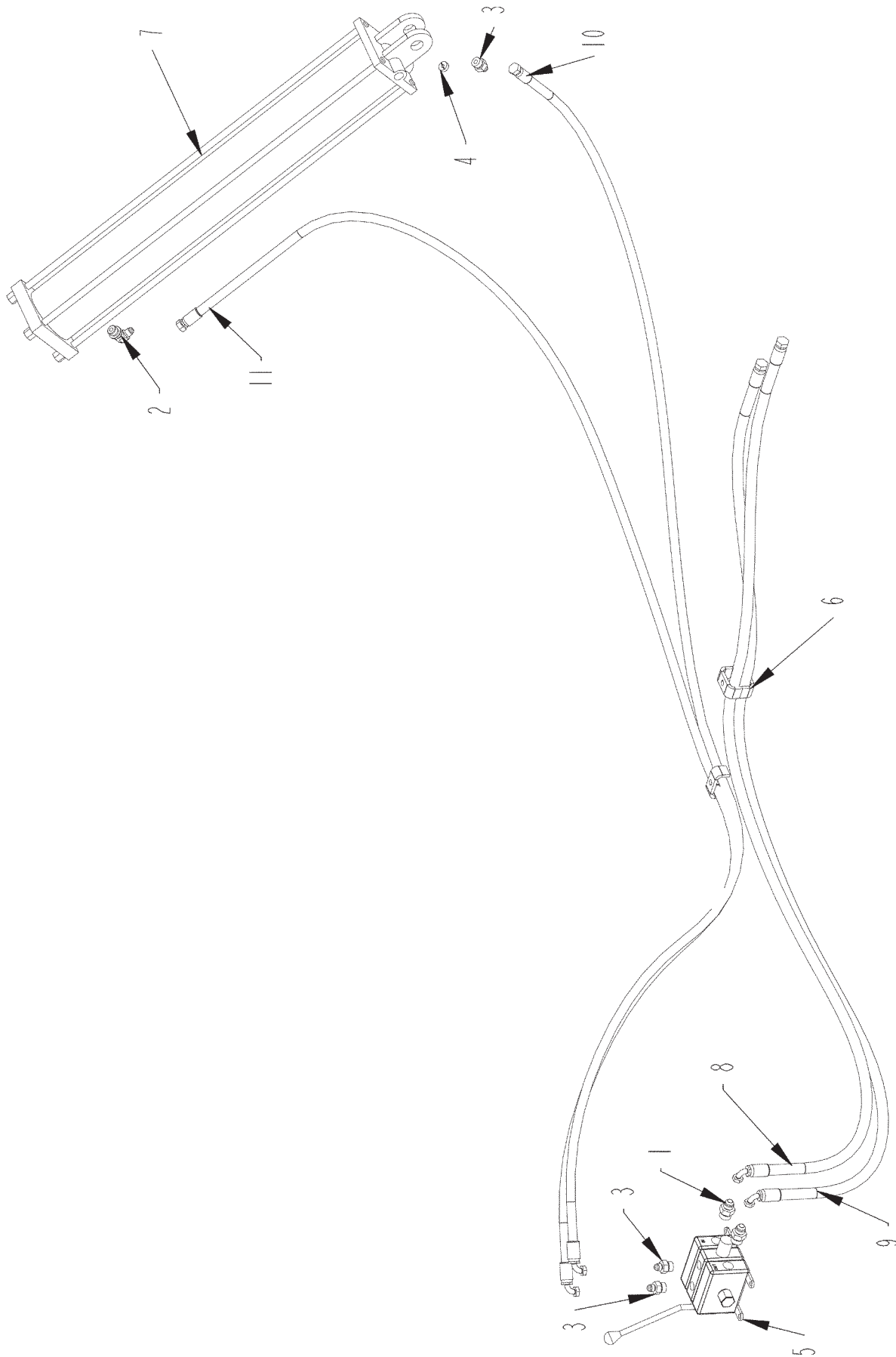
# HYDRAULIC COOLER



## HYDRAULIC COOLER

ITEM	PART	QTY.	PART DESCRIPTION
1	3800712	2	FTG\1-5/16MORX1-5/8MJIC\90
2	4200167	1	RAD\HYD\DCS16\12VDC
3	3701354	1	HOSE\HYD\1-1/4X130\1-5/8FJICX1/5/8FJIC\90 OUT PORT OF COOLER TO HYD TANK TOP FILTER
4	3701355	1	HOSE\HYD\1-1/4X92\1-5/16FJICX1-5/8FJIC BRANCH TANK PORT CONVEYOR VALVE TO IN PORT COOLER
	<b>NOT SHOWN</b>		
	5700897	1	SENSOR\TEMP
	3800949	1	FTG\3/4MORX1/8FPIADPT

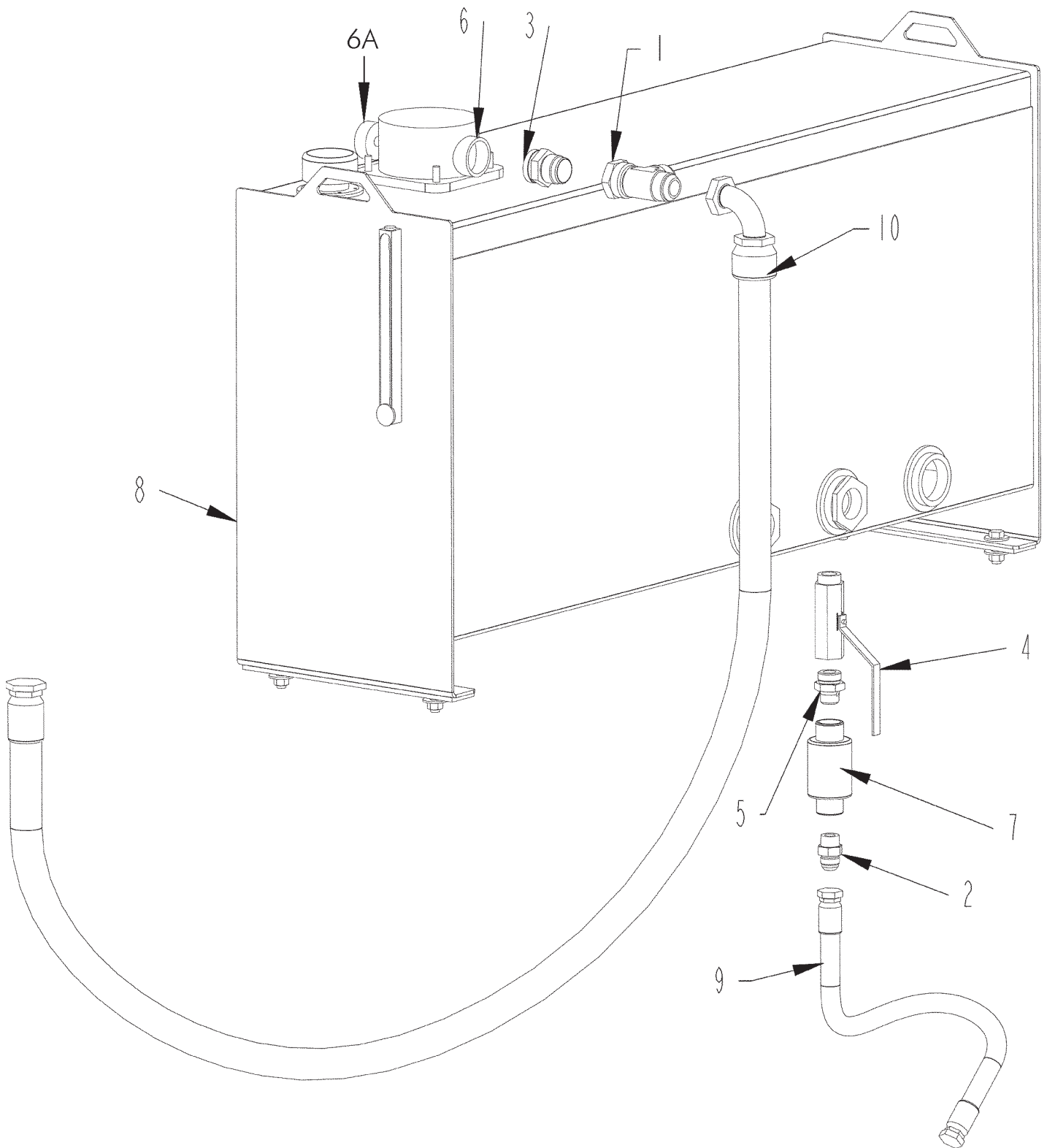
# TUB PLATFORM VALVE HYDRAULICS



**TUB PLATFORM VALVE HYDRAULICS**

<b>ITEM</b>	<b>PART</b>	<b>QTY.</b>	<b>PART DESCRIPTION</b>
1	3800328	2	FTG\7/8MORX3/4MJIC\ADPT
2	3800453	1	FTG\3/4MORX9/16MJIC\90
3	3800530	3	FTG\3/4MORX9/16MJIC\ST
4	3800844	1	FTG\3/4MOR\ORIFICE\0.062"
5	4000478	1	VALVE\HYD\1-BANKW/NOSWITCH
6	4700777	3	CLMP\HOSE\1/2
7	4100144	1	CYL\HYD\4X30\1-3/4 ROD\CLEVIS ENDS\O-RING PORTS
8	3701350	1	HOSE\HYD\1/2X136\3/4FJICX3/4FJIC\90 POWER BEYOND PORT CONVEYOR VALVE TO IN PORT PLATFORM VALVE
9	3701351	1	HOSE\HYD\1/2X130\3/4FJICX3/4FJIC\90 TANK PORT CONVEYOR RAISE/LOWER VALVE OUT PORT PLATFORM VALVE
10	3701352	1	HOSE\HYD\3/8X157\9/16FJICX9/16FJIC90 OUTSIDE PORT PLATFORM VALVE TO CAP END PLATFORM TILT CYL.
11	3701353	1	HOSE\HYD\3/8X196\9/16FJICX9/16FJIC90 INSIDE PORT PLATFORM VALVE TO ROD END TUB TILT CYL.

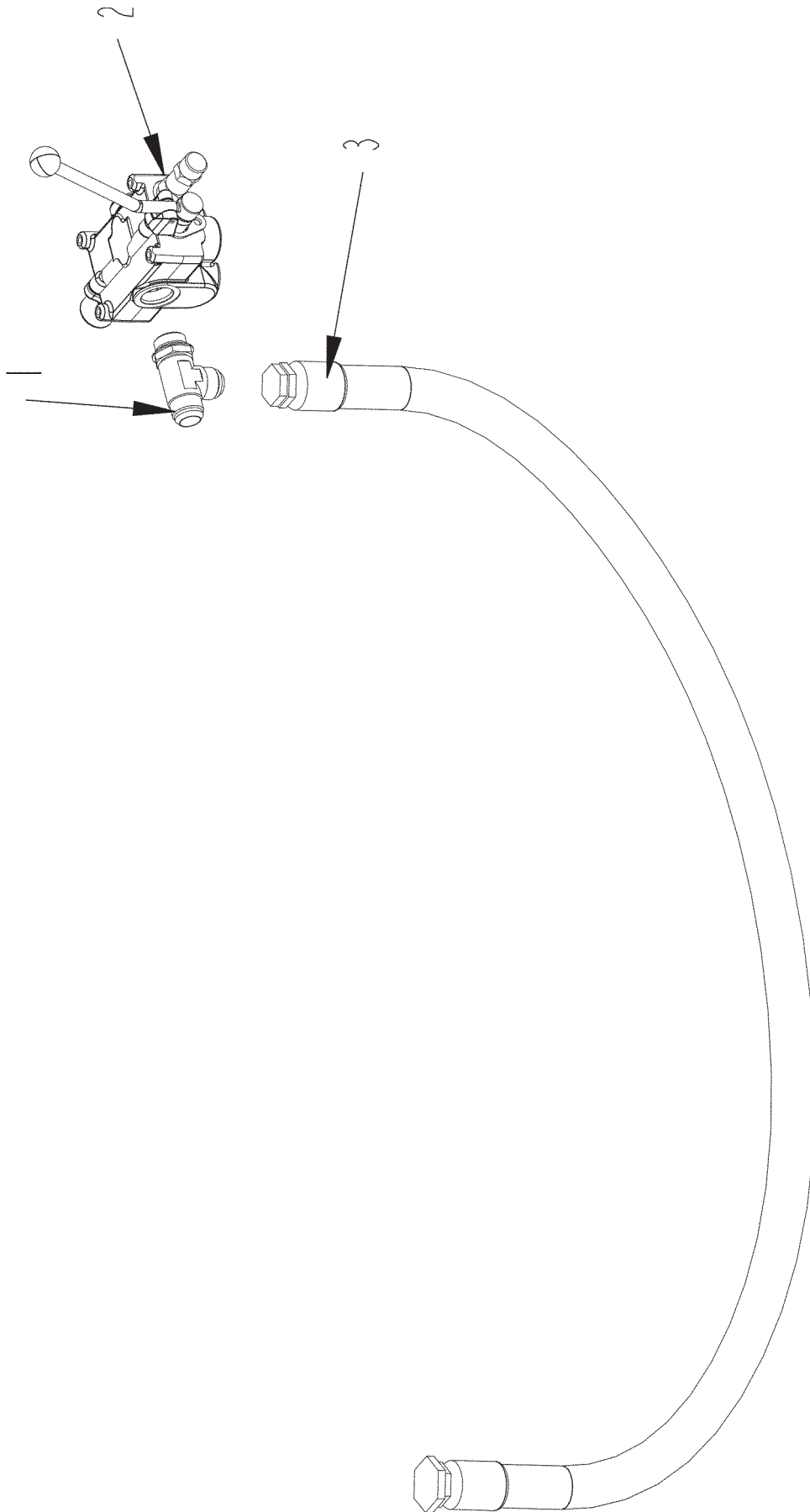
# OIL TANK HYDRAULICS



## OIL TANK HYDRAULICS

ITEM	PART	QTY.	PART DESCRIPTION
1	3800486	1	FTG\1-5/8FJICX1-5/8MJICX1-5/8MJIC\RUN;TEE
2	3800539	1	FTG\1-1/16MJICX3/4MP\ST\SOLID
3	3800808	1	FTG\1-7/8MORX1-5/8MJIC\ST
4	3800950	1	VALVE\BALL\1\1-5/16MORX1-5/16FOR
5	3800951	1	FTG\1-5/16MORX3/4MP
6	4400043	1	FILTER\HYDRAULIC\RETURN\IN-TANK ELEMENT 4400074
6A	4400066		GAUGE\FLTR\25PSI\1/8NPTF\COLOR CODED
7	4400141	1	FLTR\HYD\SUCT\INLN\10GPM
8	4502412	1	TANK\OIL\60GAL
9	3700908	1	HOSE\HYD\3/4X21\1-1/16FJCX1-1/16FJC BOTTOM PORT HYD OIL TANK SUCTION PORT CASSAP PUMP
10	3701354	1	HOSE\HYD\1-1/4X130\1-5/8FJICX1/5/8FJIC\90 OUT PORT OF COOLER TO HYD TANK TOP FILTER

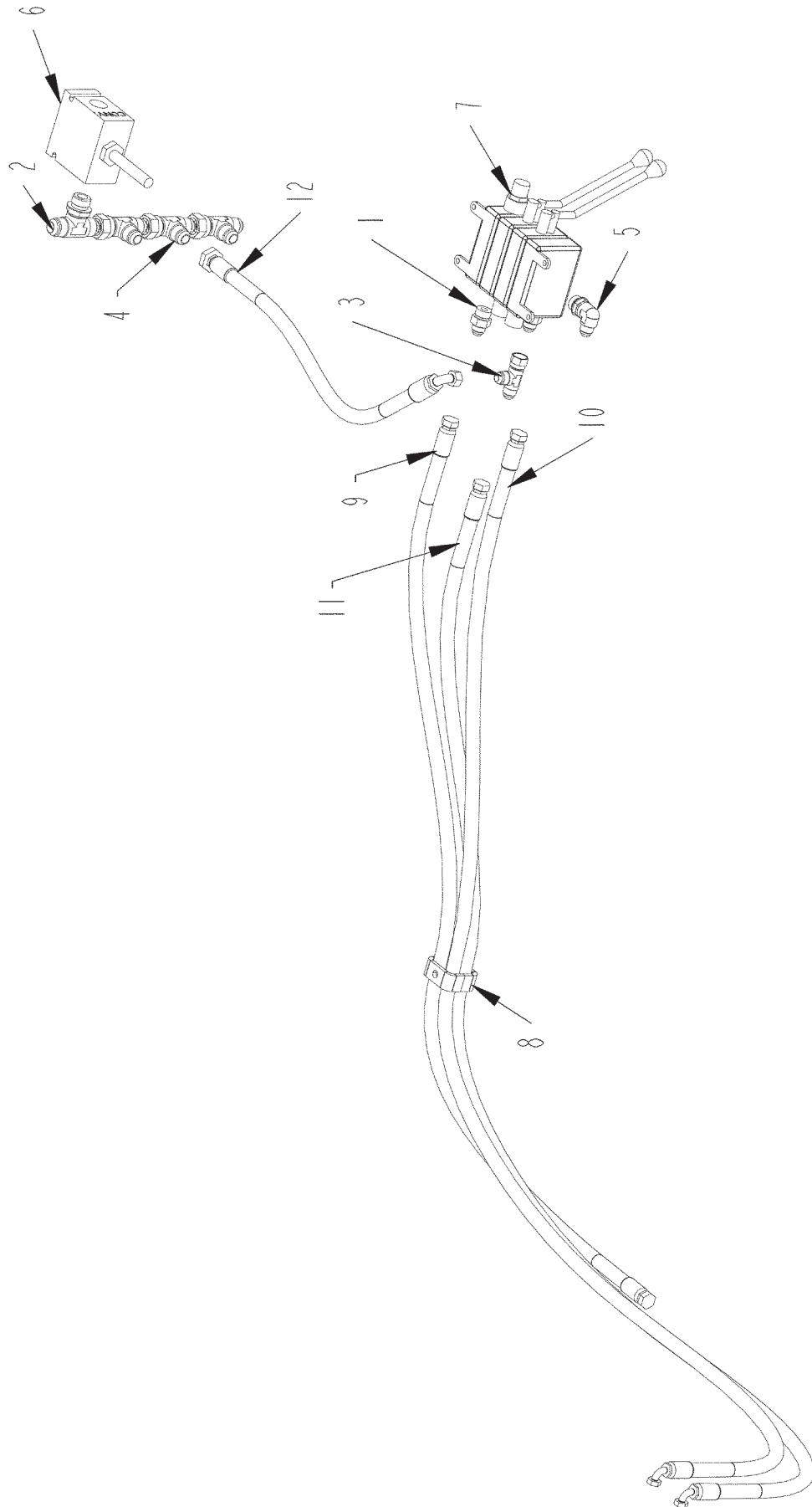
**CONVEYOR ON/OFF VALVE HYDRAULICS**



## CONVEYOR ON/OFF VALVE HYDRAULICS

ITEM	PART	QTY.	PART DESCRIPTION
1	3800842	1	FTG\1-5/16MORX1-5/16MJCX1-5/16MJIC\RUN;TEE
2	4000432	1	VALVE\HYD\OC\2POS\4WAY\45GPM
3	3701355	1	HOSE\HYD\1-1/4X92\1-5/16FJICX1-5/8FJIC BRANCH TANK PORT CONVEYOR VALVE TO IN PORT COOLER

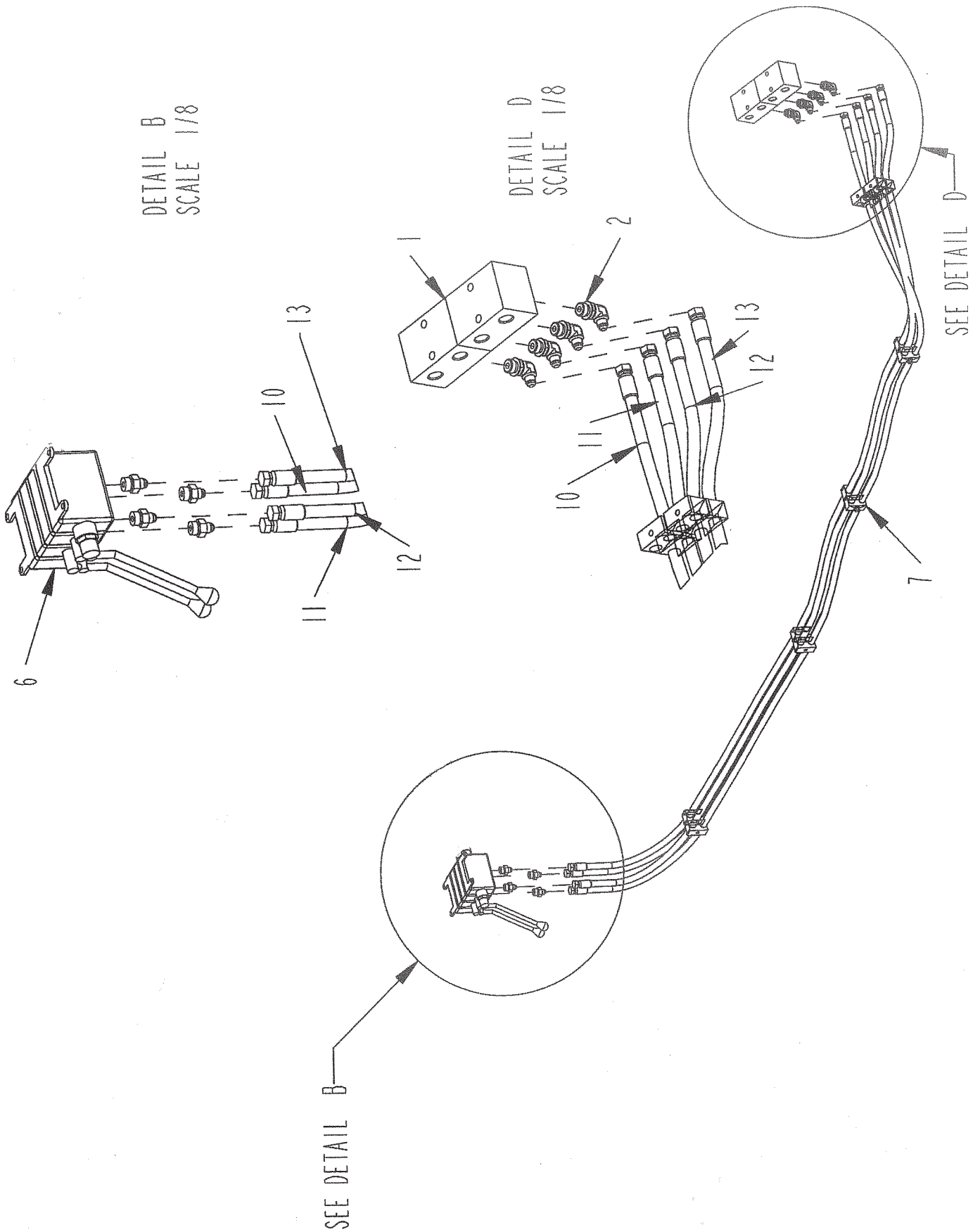
# CONVEYOR FOLD/UNFOLD & RAISE/LOWER VALVE HYDRAULICS



**CONVEYOR FOLD/UNFOLD & RAISE/LOWER VALVE HYDRAULICS**

<b>ITEM</b>	<b>PART</b>	<b>QTY.</b>	<b>PART DESCRIPTION</b>
1	3800328	2	FTG\7/8MORX3/4MJIC\ADPT
2	3800481	1	FTG\1-1/16MJICX1-1/16MJICX1-1/16MOR\BR;TEE
3	3800484	1	FTG\3/4FJICSX3/4MJICX3/4MJIC\RUN;TEE
4	3800670	3	FTG\1-1/16FJICX1-1/16MJICX1-1/16MJIC\RUN;TEE
5	3800696	1	FTG\7/8MORX3/4MJIC\90
6	4000429	1	VALVE\HYD\SOL\12V\2POS\3WAY
7	4000477	1	VALVE\HYD\2-BANK\W\NOSWTCH
8	4700777	2	CLMP\HOSE\1/2
9	3701349	1	HOSE\HYD\1/2X 71\3/4FJICX3/4FJIC PRESSURE PORT CASSAPA PUMP TO IN PORT CONVEYOR VALVE
10	3701350	1	HOSE\HYD\1/2X136\3/4FJICX3/4FJIC\90 POWER BEYOND PORT CONVEYOR VALVE TO IN PORT PLATFORM VALVE
11	3701351	1	HOSE\HYD\1/2X130\3/4FJICX3/4FJIC\90 TANK PORT CONVEYOR RAISE/LOWER VALVE OUT PORT PLATFORM VALVE
12	3701011	1	HOSE\HYD\1/2X31\3/4FJICSX3/4FJIC90 TEE ON TANK PORT CONVEYOR RAISE/LOWER VALVE TO BRANCH 2ND TEE SELECTOR VALVE

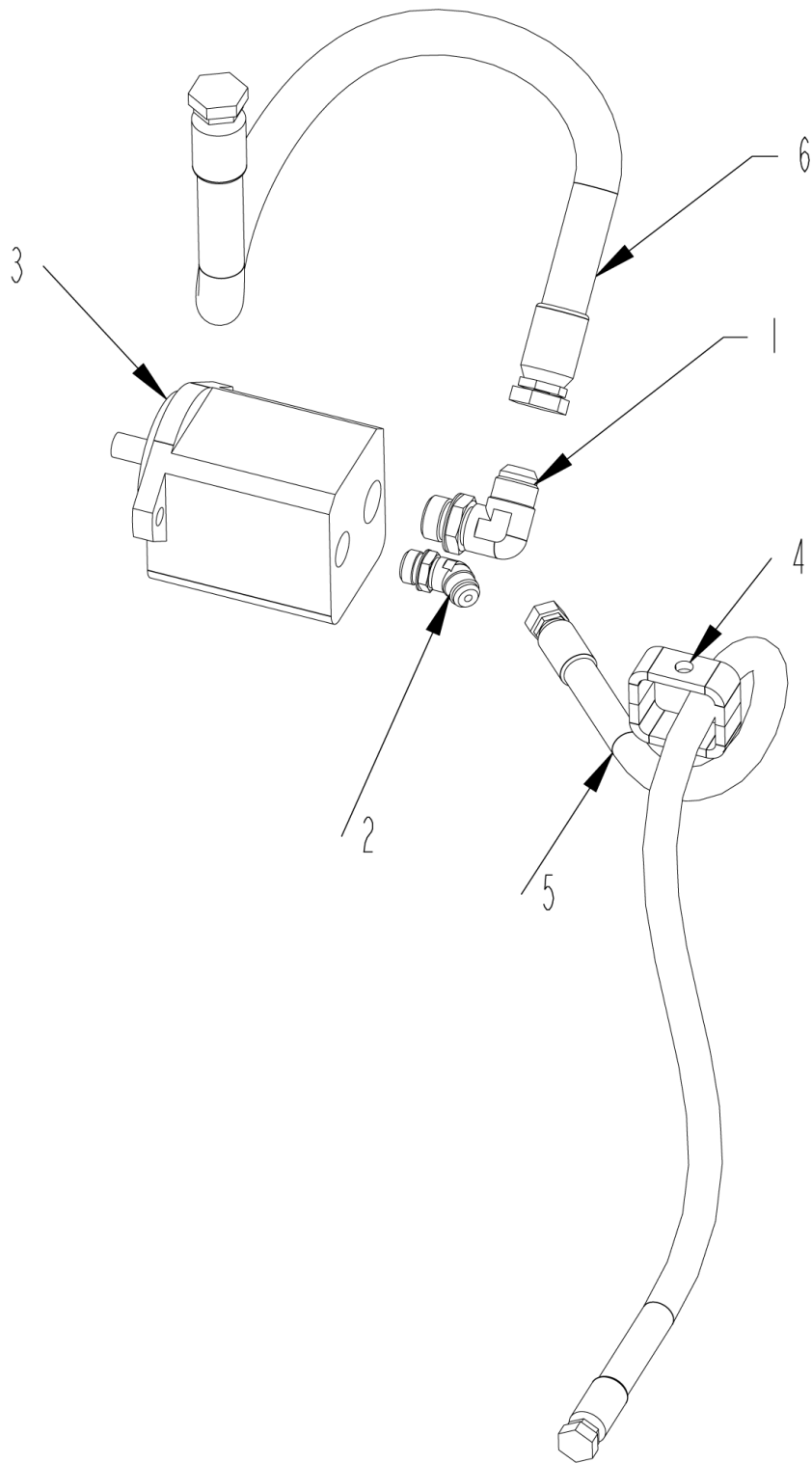
**CONVEYOR FOLD/UNFOLD & RAISE/LOWER VALVE HYDRAULICS  
DETAILS B-D**



**CONVEYOR FOLD/UNFOLD & RAISE/LOWER VALVE HYDRAULICS  
DETAILS B-D**

<b>ITEM</b>	<b>PART</b>	<b>QTY.</b>	<b>PART DESCRIPTION</b>
1	3800428	2	MNFLD\DBL;TEE\BLK\3/4FOR
2	3800453	4	FTG\3/4MORX9/16MJIC\90
3	3800530	6	FTG\3/4MORX9/16MJIC\ST
4	3800694	2	FTG\3/4FOR\QUICK;CPLR\MALE
5	3800903	1	FTG\HYD\3/4MORX3/4FOR\CHK
6	4000477	1	VALVE\HYD\2-BANK\W\NOSWTCH
7	7501387	6	CLMP\HOSE\CUSH\3/8\TWIN
10	3700988	1	HOSE\HYD\3/8X166\9/16FJICS PORT B1 CONVEYOR LIFT TO FRONT TOP FORWARD DIVIDER BLOCK
11	3700988	1	HOSE\HYD\3/8X166\9/16FJICS PORT A1 CONVEYOR LIFT TO REAR TOP FORWARD DIVIDER BLOCK
12	3700988	1	HOSE\HYD\3/8X166\9/16FJICS PORT A2 CONVEYOR FOLD TO FRONT TOP REAR DIVIDER BLOCK
13	3700988	1	HOSE\HYD\3/8X166\9/16FJICS PORT B2 CONVEYOR FOLD TO REAR TOP REAR DIVIDER BLOCK

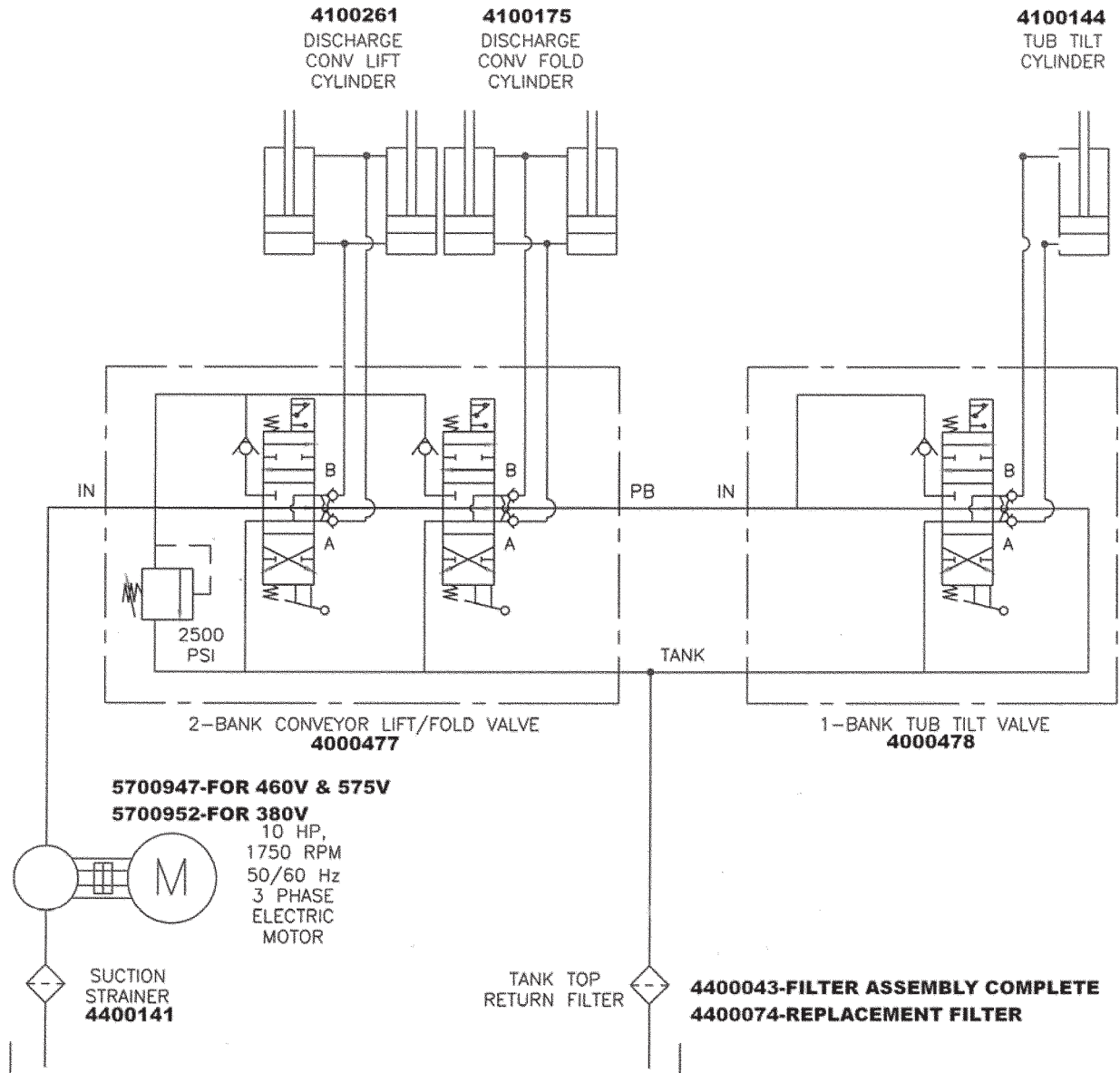
**CASSAPA PUMP**



**CASSAPA PUMP**

<b>ITEM</b>	<b>PART</b>	<b>QTY.</b>	<b>PART DESCRIPTION</b>
1	3800279	1	FTG\1-1/16MORX1-1/16MJIC\90
2	3200675	1	FTG\7/8MORX3/4MJIC\45
3	4200124	1	PUMP\HYD\89CID\CASAPPA
4	4700777	2	CLMP\HOSE\1/2
5	3701349	1	HOSE\HYD\1/2X 71\3/4FJICX3/4FJIC PRESSURE PORT CASSAPA PUMP TO IN PORT CONVYOR VALVE
6	3700908	1	HOSE\HYD\3/4X21\1-1/16FJCX1-1/16FJC BOTTOM PORT HYD OIL TANK SUCTION PORT CASSAP PUMP

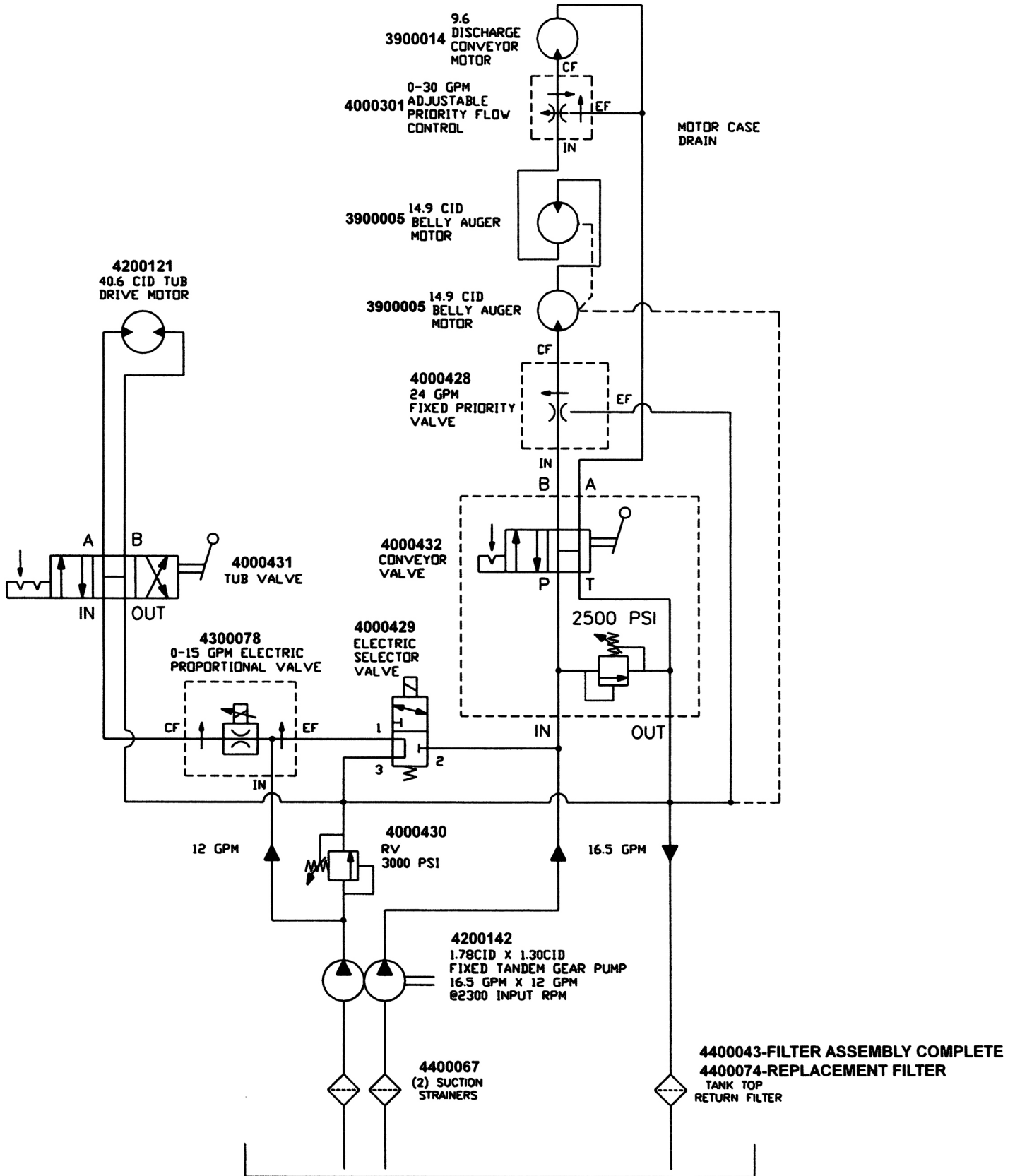
**AUXILLARY HYDRAULIC SCHEMATIC**

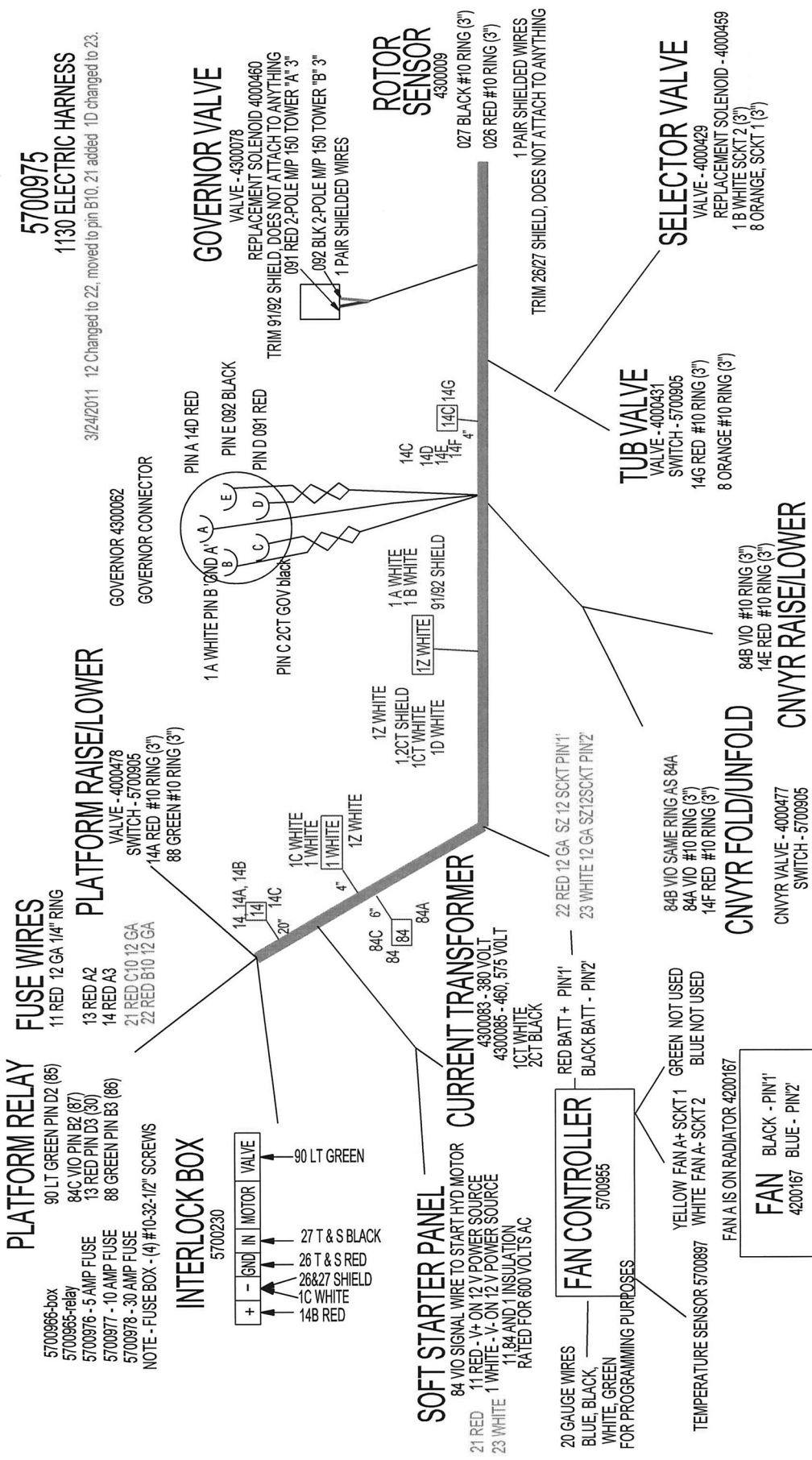


MODEL 1130 ELECTRIC AUXILLARY  
HYDRAULIC SCHEMATIC

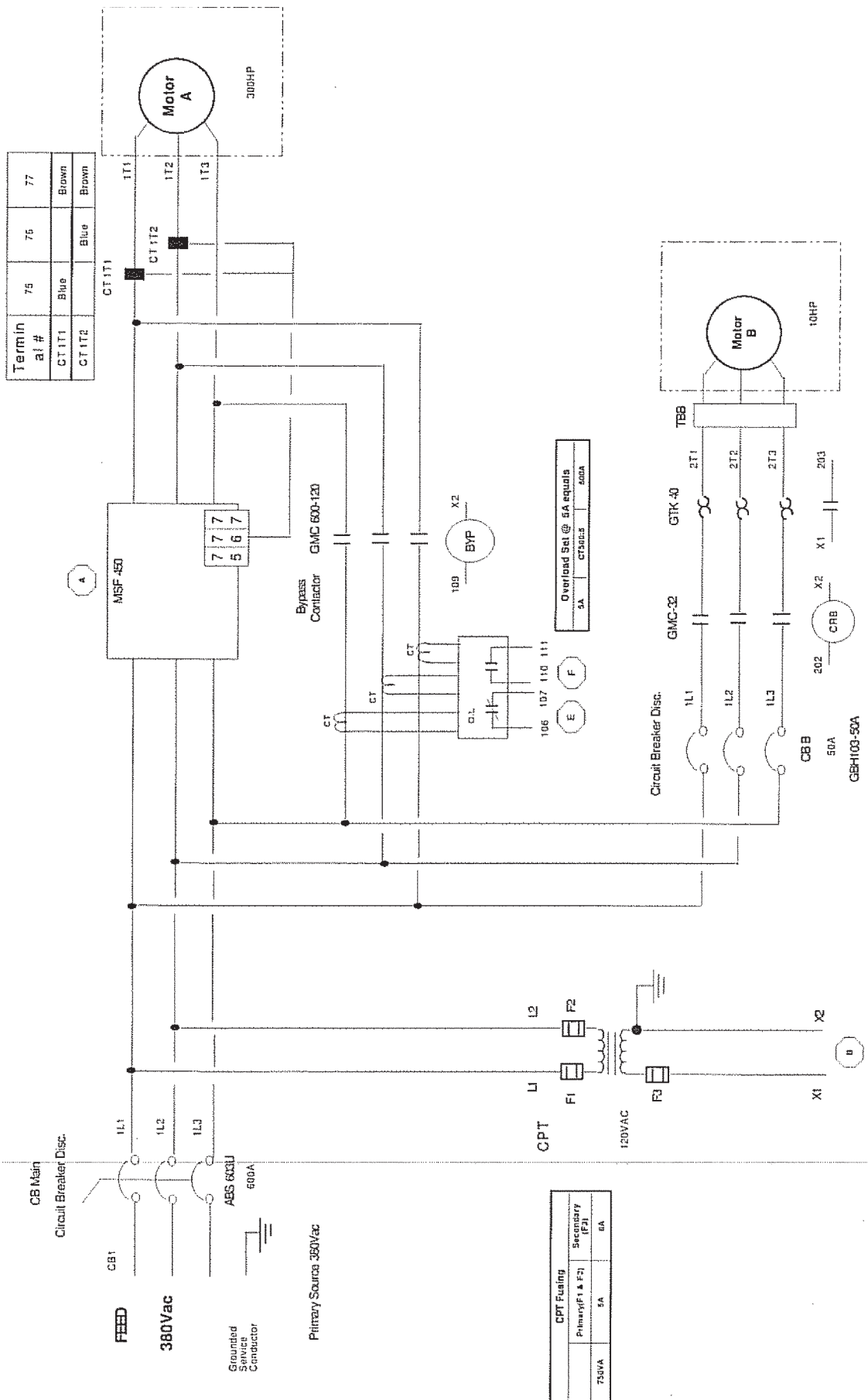


**1130 TUB/TWIN AUGER CONVEYOR HYDRAULIC CIRCUIT  
(S.N. 113040130 AND UP)**

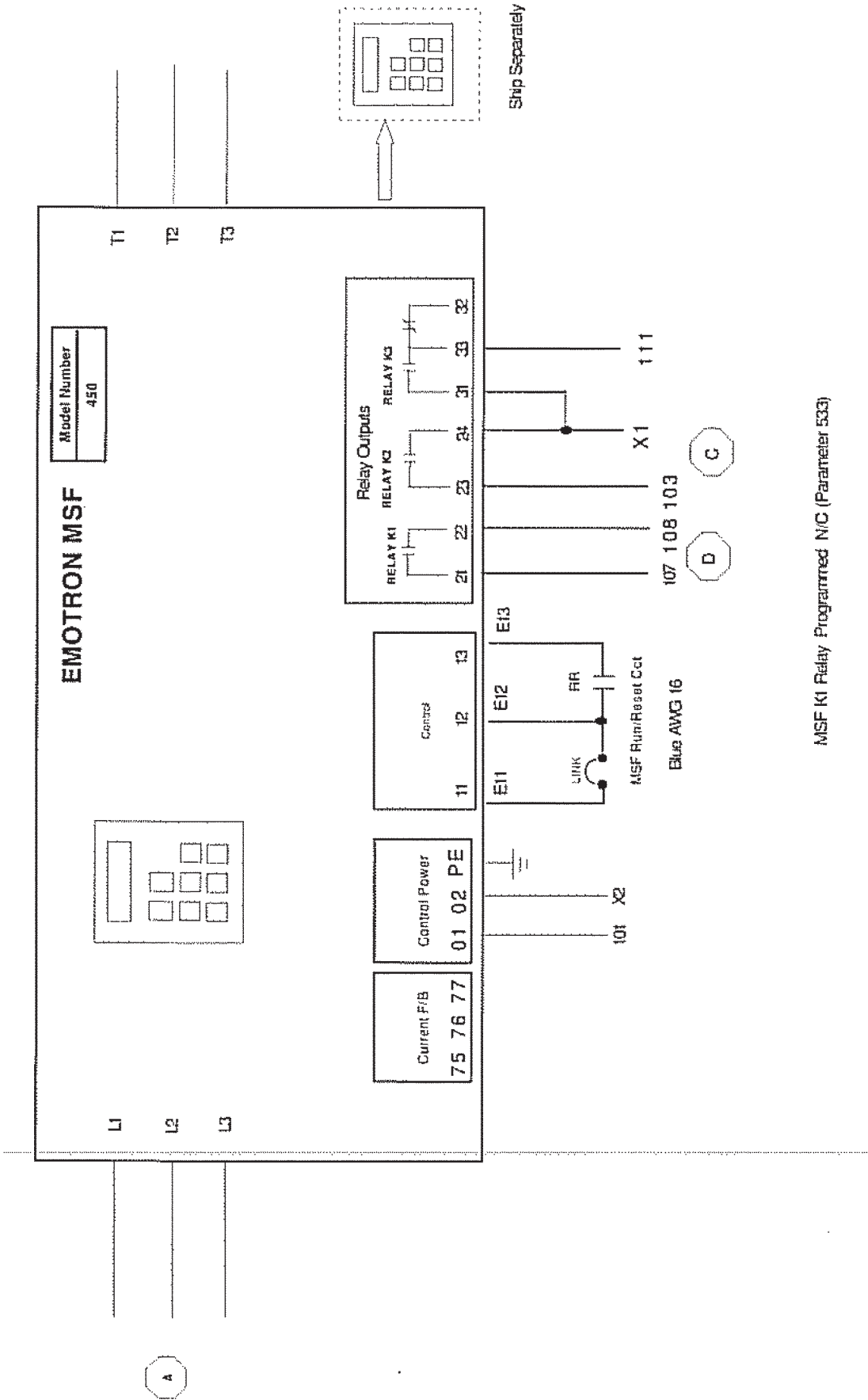




SCHEMATIC 460 VOLT #1

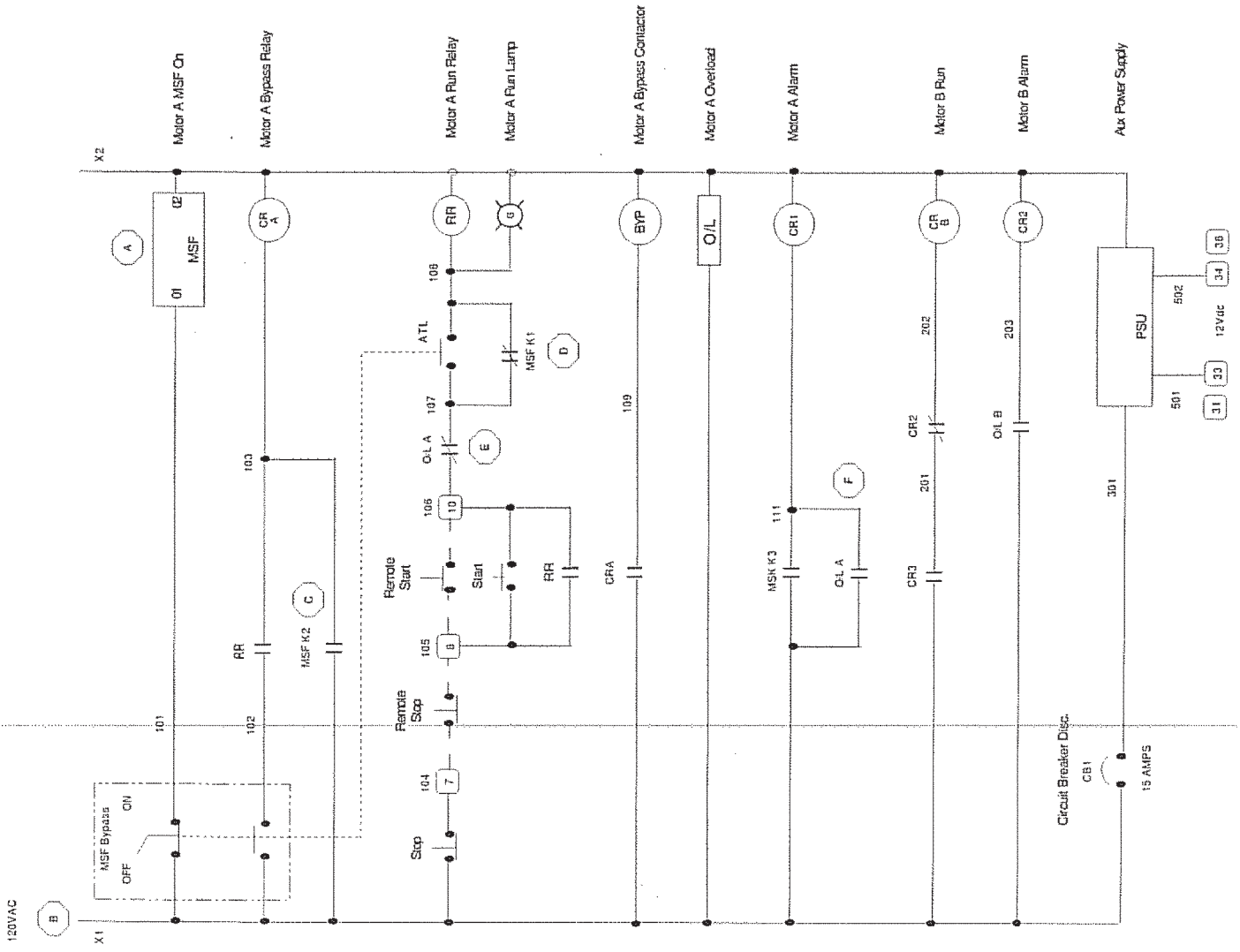
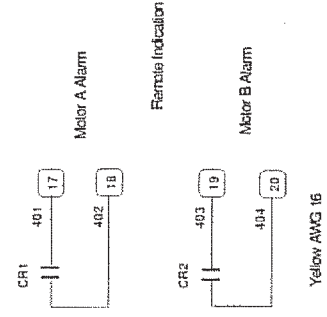
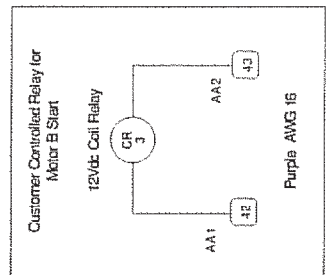
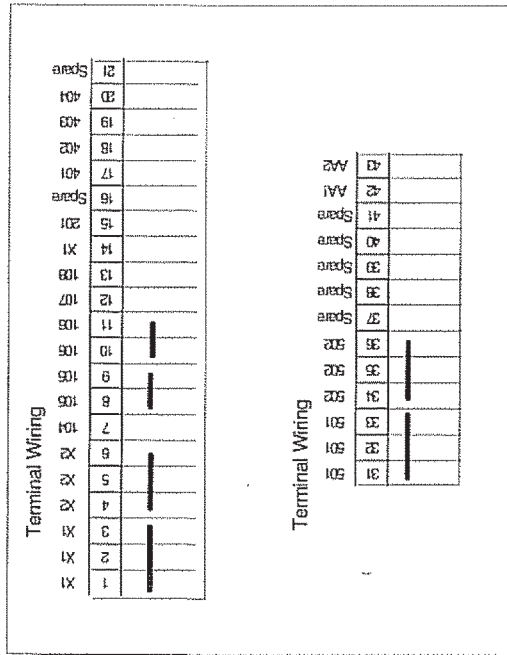


**SCHEMATIC 460 VOLT #2**



MSF K1 Relay Programmed N/C (Parameter 533)

SCHEMATIC 460 VOLT #3





Please fill out the delivery report on the following pages. The white copy is to be returned to:

**DuraTech Industries International Inc.**  
**P.O. Box 1940**  
**Jamestown, ND**  
**58402-1940**

The yellow copy is the dealer copy; the pink copy is to be retained by the customer.