

Installation and Parts Reference Manual

107/107C DRILL™

LEGUME BOX



PRODUCT INFORMATION



0500071 • MARCH 2017

DURATECH INDUSTRIES INTERNATIONAL INC.
PO Box 1940, JAMESTOWN, ND 58402-1940
TEL: (701) 252-4601 • FAX: (701) 252-0502
WWW.DURATECHINDUSTRIES.NET • WWW.HAYBUSTER.COM

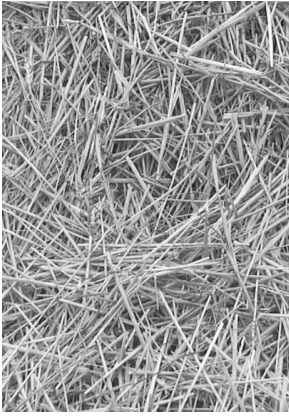

HAYBUSTER[®]
A Tradition of Innovation Since 1966

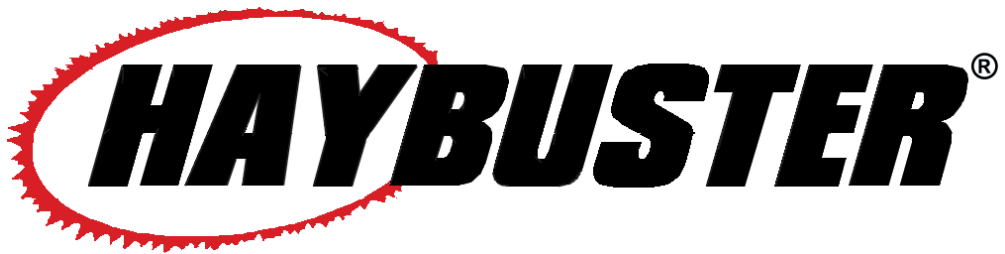
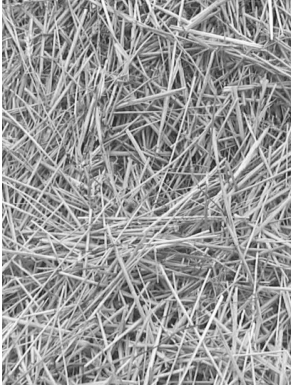



107/107C DRILL™ LEGUME BOX

Installation and Parts Reference Manual

DuraTech Industries International Inc. (DuraTech Industries) has made every effort to assure that this manual completely and accurately describes the installation and maintenance of the Legume Box option for the 107/107c Drill™ as of the date of publication. DuraTech Industries reserves the right to make updates to the machine from time to time. Even in the event of such updates, you should still find this manual to be appropriate for the safe operation and maintenance of your unit.

This manual, as well as materials provided by component suppliers to DuraTech Industries are all considered to be part of the information package. Every operator is required to read and understand these manuals, and they should be located within easy access for periodic review.

 **DURATECH**® and  are registered trademarks of Duratech Industries International, Inc. 107/107C DRILL is a trademark of Duratech Industries International, Inc.

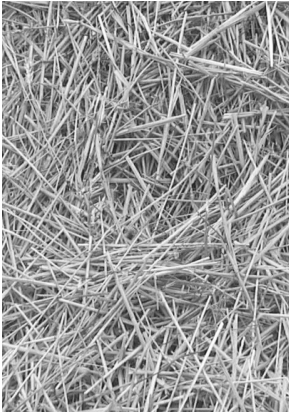

HAYBUSTER[®]
A Tradition of Innovation Since 1966

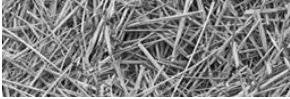

Cover and above photo show the legume box installed with optional drop tube assembly

Foreword

All personnel must read and understand before operating unit

- Foreword and Section 1, important safety information.
- Section 2, "Installation," to verify that the machine has been prepared for use.

Appropriate use of the unit

The legume box attachment features fluted-feed cups which are capable of accurately metering small seeds even at very low rates. The hopper will hold up to 150 lbs. of seed.

Operator protection

As with all machinery, care needs to be taken by the operator in order to insure the safety of the operator and those in the surrounding area.



WARNING: Operators and those observing the operation of the 107/107C GRAIN DRILL are required to wear head, eye, and ear protection. No loose clothing is allowed.

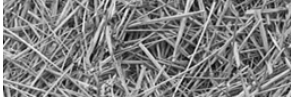
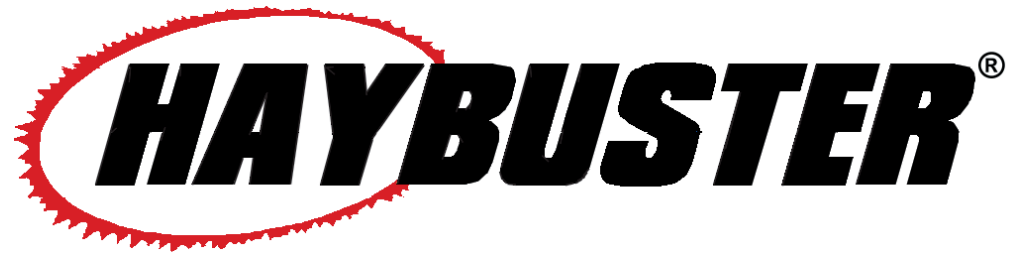
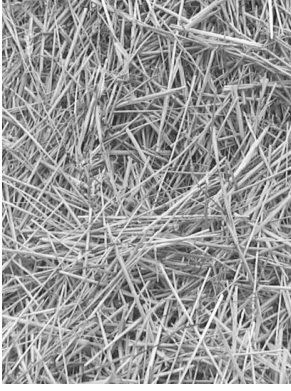

TABLE OF CONTENTS

Part 1: Operating Instructions	2
107/107C Legume Box Introduction	2
Section 1: Safety.....	3
1.1 Safety-alert symbols.....	3
1.2 Operator - personal equipment.....	5
1.3 Machine safety labels.....	6
1.4 Shielding.....	8
1.5 Personal equipment	8
1.6 Safety review	8
Section 2: Installation.....	11
2.1 Drill Legume Box Attachment.....	11
2.2 Legume Hopper Shipping Kit	15
Part 2: Parts Reference.....	19
LEGUME BOX ASSEMBLY.....	20
SEED INDEX ASSEMBLY LEGUME BOX.....	22
CUP ASSEMBLY LEGUME BOX.....	23
LEGUME DROP TUBE ASSEMBLY.....	24
LEGUME DROP TUBE ASSEMBLY (107C)	26
MOUNTING BRACKET.....	28
LEGUME BOX Documentation Comment Form	29



107/107C DRILLTM LEGUME BOX

Installation and Parts Reference Manual

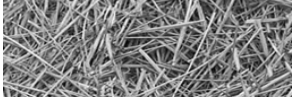

107/107C Legume Box Introduction

The legume box attachment features fluted-cups that are capable of accurately metering small seeds even at very low rates. The hopper will hold up to 150 pounds of seed.

NOTE – SERIAL NUMBER INFORMATION

- The complete legume box part number is 8700030.
- The complete seed cup kit is 8700036. This includes (2) 8700015 and (2) 8700016, seed cups for legume boxes.
- A new style drill (2672 and up) needs part 8700030.
- An older drill (2671 and below) needs parts 8700030 and 8700036.



Special Note: When reference is made as to front, rear, right hand or left hand of this machine, the reference is always made from standing at the rear end of the machine and looking towards the hitch. Always use serial number and model number when referring to parts or problems. Please obtain your serial number and write it below for your future reference.

MODEL: 107/107C **DRILL LEGUME BOX** **SERIAL NO.** _____



Section 1: Safety

The safety of the operator is of great importance to DuraTech Industries/Haybuster. We have provided decals, shield and other safety features to aid you in using your machine safely. In addition, we ask you to be a careful operator who will properly use and service your Haybuster equipment.



WARNING: FAILURE TO COMPLY WITH SAFETY INSTRUCTIONS THAT FOLLOW WITHIN THIS MANUAL COULD RESULT IN SEVERE PERSONAL INJURY OR DEATH. BEFORE ATTEMPTING TO OPERATE THIS MACHINE, CAREFULLY READ ALL INSTRUCTIONS CONTAINED WITHIN THIS MANUAL. ALSO READ THE INSTRUCTION MANUAL PROVIDED WITH YOUR TRACTOR.

THIS MACHINE IS NOT TO BE USED FOR ANY PURPOSE OTHER THAN THOSE EXPLAINED IN THE OPERATOR'S MANUAL, ADVERTISING LITERATURE OR OTHER DURATECH INDUSTRIES WRITTEN MATERIAL PERTAINING TO THE 107 GRAIN DRILL.

1.1 Safety-alert symbols

Decals are illustrated in **Part 2: Parts Reference**.

The safety decals located on your machine contain important and useful information that will help you operate your equipment safely.

To assure that all decals remain in place and in good condition, follow the instructions below:

- Keep decals clean. Use soap and water - not mineral spirits, adhesive cleaners and other similar cleaners that will damage the decal.
- Replace all damaged or missing decals. When attaching decals, surface temperature of the machine must be at least 40° F (5° C). The surface must be also be clean and dry.
- When replacing a machine component to which a decal is attached, be sure to also replace the decal.
- Replacement decals can be purchased from your Haybuster dealer.

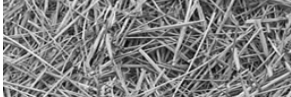

DuraTech Industries uses industry accepted ANSI standards in labeling its products for safety and operational characteristics.



Safety-Alert Symbol

Read and recognize safety information. Be alert to the potential for personal injury when you see this safety-alert symbol.

DANGER: Indicates an imminently hazardous situation that, if not avoided, will result in death or serious injury. This signal word is to be limited to the most extreme situations, typically for machine components that, for functional purposes, cannot be guarded.

WARNING: Indicates a potentially hazardous situation that, if not avoided, could result in death or serious injury, and includes hazards that are exposed when guards are removed. It may also be used to alert against unsafe practices.

CAUTION: Indicates a potentially hazardous situation that, if not avoided, may result in minor or moderate injury. It may also be used to alert against unsafe practices.

This manual uses the symbols to the right to denote important safety instructions and information.

The **DANGER**, **WARNING** and **CAUTION** symbols are used to denote conditions as stated in the text above. Furthermore, the text dealing with these situations is surrounded by a box with a white background, will begin with **DANGER**, **WARNING**, or **CAUTION**.

The **INFORMATION** symbol is used to denote important information or notes in regards to maintenance and use of the machine. The text for this information is surrounded by a box with a light grey background, and will begin with either **Important** or **Note**.



DANGER:
Signal word - White Lettering/Red Background
Safety Alert Symbol - White Triangle/Red Exclamation Point



WARNING:
Signal word - Black Lettering/Orange Background
Safety Alert Symbol - Black Triangle/Orange Exclamation Point



CAUTION:
Signal word - Black Lettering/Yellow Background
Safety Alert Symbol - Black Triangle/Yellow Exclamation Point



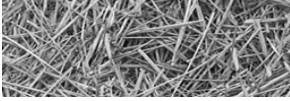

1.2 Operator - personal equipment

THE OPERATOR

Physical Condition

You must be in good physical condition and mental health and not under the influence of any substance (drugs, alcohol) which might impair vision, dexterity or judgment.

Do not operate a **107/107C DRILL** when you are fatigued. Be alert - If you get tired while operating your **107/107C DRILL**, take a break. Fatigue may result in loss of control. Working with any farm equipment can be strenuous. If you have any condition that might be aggravated by strenuous work, check with your doctor before operating

Proper Clothing



Clothing must be sturdy and snug-fitting, but allow complete freedom of movement. Avoid loosefitting jackets, scarfs, neckties, jewelry, flared or cuffed pants, unconfined long hair or anything that could become entangled with the machine.



Protect your hands with gloves when handling flail and sections. Heavyduty, nonslip gloves improve your grip and protect your hands.



Good footing is most important. Wear sturdy boots with nonslip soles. Steel-toed safety boots are recommended.



To reduce the risk of injury to your eyes never operate a **107/107C DRILL** unless wearing goggles or properly fitted safety glasses with adequate top and side protection.



Tractor noise may damage your hearing. Always wear sound barriers (ear plugs or ear muffers) to protect your hearing. Continual and regular users should have their hearing checked regularly.

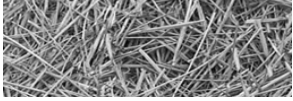



1.3 Machine safety labels

The safety decals located on your machine contain important information that will help you operate your equipment. Become familiar with the decals and their locations.





WARNING: FOR YOUR PROTECTION AND PROTECTION OF OTHERS, **PRACTICE THE FOLLOWING SAFETY RULES.**

1. BEFORE OPERATING THIS MACHINE, READ THE OPERATOR'S MANUALS SUPPLIED WITH THIS MACHINE AND YOUR TRACTOR.
2. CHECK OPERATORS MANUALS TO BE SURE YOUR TRACTOR MEETS THE MINIMUM REQUIREMENTS FOR THIS MACHINE.
3. READ ALL DECALS PLACED ON THIS MACHINE FOR YOUR SAFETY AND CONVENIENCE.
4. NEVER ALLOW RIDERS ON THIS IMPLEMENT OR THE TRACTOR.
5. KEEP OTHERS AWAY FROM THIS MACHINE WHILE IN OPERATION.
6. KEEP ALL SHIELDS IN PLACE WHILE MACHINE IS OPERATING.
7. KEEP HANDS, FEET, LOOSE CLOTHING, ETC., AWAY FROM POWER DRIVEN PARTS.
8. ALWAYS SHUT OFF MACHINE AND ENGINE BEFORE SERVICING, UNCLOGGING, INSPECTING, OR WORKING NEAR THIS MACHINE FOR ANY REASON. ALWAYS PLACE TRANSMISSION IN PARK OR SET PARK BRAKE AND WAIT FOR ALL MOVEMENT TO STOP BEFORE APPROACHING THIS MACHINE.

 WARNING	 ADVERTENCIA
<p>FOR YOUR PROTECTION AND PROTECTION OF OTHERS, PRACTICE THE FOLLOWING SAFETY RULES.</p> <ol style="list-style-type: none"> 1. BEFORE OPERATING THIS MACHINE, READ THE OPERATOR'S MANUALS SUPPLIED WITH THIS MACHINE AND YOUR TRACTOR. 2. CHECK OPERATORS MANUALS TO BE SURE YOUR TRACTOR MEETS THE MINIMUM REQUIREMENTS FOR THIS MACHINE. 3. READ ALL DECALS PLACED ON THIS MACHINE FOR YOUR SAFETY AND CONVENIENCE. 4. NEVER ALLOW RIDERS ON THIS IMPLEMENT OR THE TRACTOR. 5. KEEP OTHERS AWAY FROM THIS MACHINE WHILE IN OPERATION. 6. KEEP ALL SHIELDS IN PLACE WHILE MACHINE IS OPERATING. 7. KEEP HANDS, FEET, LOOSE CLOTHING, ETC., AWAY FROM POWER DRIVEN PARTS. 8. ALWAYS SHUT OFF MACHINE AND ENGINE BEFORE SERVICING, UNCLOGGING, INSPECTING, OR WORKING NEAR THIS MACHINE FOR ANY REASON. ALWAYS PLACE TRANSMISSION IN PARK OR SET PARK BRAKE AND WAIT FOR ALL MOVEMENT TO STOP BEFORE APPROACHING THIS MACHINE. 	<p>SIGA LAS REGLAS SIGUIENTES DE SEGURIDAD PARA SU PROTECCION Y LA PROTECCION DE OTROS</p> <ol style="list-style-type: none"> 1. LEA LOS MANUALES DEL OPERADOR INCLUIDOS CON ESTA MAQUINA Y SU TRACTOR ANTES DE OPERAR ESTA MAQUINA. 2. PARA ASEGURARSE QUE SU TRACTOR CUMPLE CON LOS REQUERIMIENTOS MÍNIMOS PARA ESTA MAQUINA, REVISE LOS MANUALES DEL OPERADOR INCLUIDOS EN LA MAQUINA. 3. PARA SU SEGURIDAD Y CONVENIENCIA, LEA TODAS LAS CALCOMANIAS COLOCADAS EN LA MAQUINA. 4. NUNCA PERMITA PASAJEROS EN ESTA MAQUINA O EN EL TRACTOR. 5. MANTENGA ALEJADOS A LOS ESPECTADORES MIENTRAS ESTA MAQUINA ESTE OPERANDO. 6. MANTENGA TODOS LOS PROTECTORES EN SU LUGAR MIENTRAS LA MAQUINA ESTE OPERANDO. 7. MANTENGA LAS MANOS, PIES, ROPAS HOLGADAS, ETC., ALEJADAS DE LAS PIEZAS PROPULSORAS. 8. SIEMPRE APAGUE LA MAQUINA Y EL MOTOR ANTES DE PRESTAR SERVICIO, DESTRABAR, INSPECCIONAR O TRABAJAR CERCA DE ESTA MAQUINA POR CUALQUIER MOTIVO. ANTES DE ACERCARSE A ESTA MAQUINA COLOQUE SIEMPRE LA TRANSMISION EN ESTACIONAMIENTO O ENGANCHE EL FRENO DE ESTACIONAMIENTO.



WARNING: FOR YOUR PROTECTION KEEP ALL SHIELDS IN PLACE AND SECURED WHILE MACHINE IS OPERATING MOVING PARTS WITHIN CAN CAUSE SEVERE PERSONAL INJURY.

 WARNING	 ADVERTENCIA
<p>FOR YOUR PROTECTION KEEP ALL SHIELDS IN PLACE AND SECURED WHILE MACHINE IS OPERATING MOVING PARTS WITHIN CAN CAUSE SEVERE PERSONAL INJURY.</p>	<p>PARA ASEGURAR SU PROTECCION, MANTENGA TODOS LOS PROTECTORES EN SU LUGAR Y ASEGURADOS MIENTRAS LA MAQUINA ESTE OPERANDO. LAS PIEZAS MOVILES INTERNAS PUEDEN CAUSAR LESIONES PERSONALES GRAVES.</p>

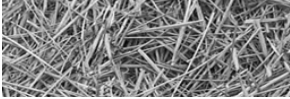

WARNING: CHEMICALS MAY CAUSE EYE, SKIN AND BREATHING PROBLEMS. WEAR FACE MASK, GLOVES AND GOGGLES. READ AND FOLLOW SAFETY INSTRUCTIONS ON THE CHEMICAL SUPPLIERS LABEL.

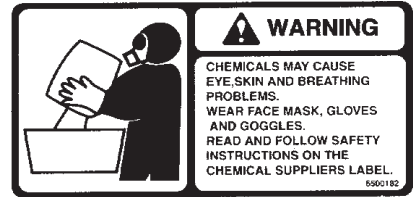

WARNING: NO RIDERS. SERIOUS PERSONAL INJURY COULD RESULT FROM RIDING ON STEP.



WARNING: DISC BLADES ARE *EXTREMELY* SHARP! WEAR HEAVY GLOVES WHEN SERVICING.

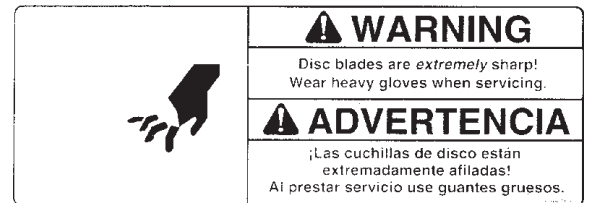

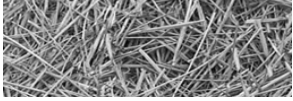

1.4 Shielding

Shields are installed for your protection. Keep them in place, and replace damaged shields.

1.5 Personal equipment

Operators of this machine are encouraged to wear head, eye, and ear protection. Loose clothing is discouraged.

1.6 Safety review

BEFORE OPERATING

- Read and follow all instructions contained in:
 - A. This Installation Manual
 - B. Your 107/107C DRILL Operator's Manual.
 - C. Tractor operator's manual.
 - D. Decals placed on the 107/107C Drill and Tractor.



NOTE: Additional copies of the above mentioned materials can be obtained from your dealer.

- Be sure all safety shields and covers are securely in place when machine is running.
- Read all warning and instructional decals placed on the machine for your safety and convenience.
- Allow only responsible, properly instructed individuals to operate machine. Carefully supervise inexperienced operators.
- Make no modifications to this equipment unless specifically requested or recommended by DuraTech Industries.
- Tighten or replace any loose or cracked bolts, chains, hoses or connections.
- The towing vehicle must be of equal or greater weight than the grain drill for adequate braking capacity.

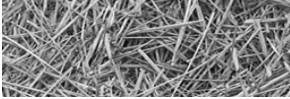

DURING OPERATION

- Exercise extreme caution with operating the drill on steep slopes or grades.
- Be sure all spectators are clear of the area where the drill is in operation or raised and lowered.
- Be sure the tractor operator is the only person riding the tractor. Allow no one to ride the drill at any time.
- Remember, loose clothing, necklaces and similar items are more easily caught in moving parts. Avoid the use of these items if possible and keep long hair confined.
- Never work under the drill when the drill is lifted up unless the safety stop bar is in position.
- Watch out for and avoid any object that might interfere with the proper operation of the machine.

DURING SERVICE & MAINTENANCE



CAUTION: Before performing any maintenance or adjustments make sure machine is NOT running. If for any reason arc welding is to be done, always ground rotor to frame of machine to prevent arcing on bearings.

- Before working on or near drill for any reason including servicing, lubricating, cleaning, inspecting or refilling, or if working under drill or detaching from tractor, install safety stop bar (next to hydraulic cylinder).
- When replacing any part on your drill, be sure to use only DuraTech Industries authorized parts.
- Relieve all pressure in the hydraulic system before disconnecting the lines or performing other work on the system. Make sure all connections are tight and the hoses and lines are in good condition before applying pressure to the system.



CAUTION: Hydraulic fluid escaping under pressure can be invisible and have enough force to penetrate the skin. When searching for a suspected leak, use a piece of wood or cardboard rather than your hands. If injured, seek medical attention immediately to prevent serious infection or reaction.

- Be careful when using a hoist or other lifting device. Use only devices that have adequate lifting capacity and be sure the chain or cable is securely attached.

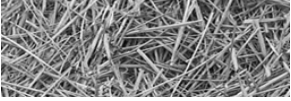

WHEN TRANSPORTING ON PUBLIC ROADS

- Use good judgment and drive carefully, especially over rough or uneven roads.
- Be sure tractor brakes are properly adjusted and foot pedals locked together.
- Check your state laws regarding the use of lights, slow moving vehicle sign, safety chain and other possible requirements.
- Do not tow drills at speeds over 20 mph. It is recommended that drills be empty of seed and fertilizer when transporting.



WARNING: FAILURE TO COMPLY WITH ANY OF THE ABOVE SAFETY INSTRUCTIONS OR THOSE THAT FOLLOW WITHIN THIS MANUAL MAY RESULT IN SEVERE INJURY OR DEATH.

THIS DRILL IS NOT TO BE USED FOR ANY PURPOSE OTHER THAN THAT FOR WHICH IT IS INTENDED AS EXPLAINED IN THE OPERATOR'S MANUAL, ADVERTISING MATERIALS AND OTHER PERTINENT WRITTEN MATERIAL. PREPARED BY DURATECH INDUSTRIES.

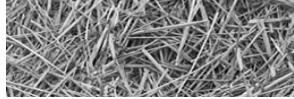

Section 2: Installation

2.1 Drill Legume Box Attachment

The legume box attachment features fluted-feed cups which are capable of accurately metering small seeds even at very low rates. The hopper will hold up to 150 lbs. of seed.



Note: Drills built before S/N 2672 for the 107 and S/N CJ50177 for the 77 will need to purchase the optional seed drop tube assembly, P/N 8400647 for the 107 and P/N 8400730 for the 77, or seed cups with hose nipples. (See Parts Book)

INSTALLATION

Step 1: Drill four 7/16" diameter holes in the front (grain) box as shown in Figure 1. Measure these holes carefully and use a good center punch to mark locations before drilling. Loosely bolt the mounting bracket to the grain box observing left hand and right hand parts.



If your drill serial number is 2672 or higher, go to step 3.
If 2671 or lower continue with step 2.

Step 2: Remove the convoluted grain hoses and unbolt the cup assemblies from the grain tank. Replace with modified cup assemblies provided with the legume box kit. Reattach the convoluted grain hoses to the cups.

Step 3: Loosen chains, sprockets and bearings and move countershaft on grain tank. Reinstall existing bearings, sprockets and chains and install 15 tooth sprocket as shown in Figure 2.

Step 4: Bolt legume box to grain tank using the four 3/8" x 1" bolts provided. The mounts welded to the rear of the legume box should go between the mounting brackets installed in Step 1. Tighten all mounting bolts securely.

Step 5: Bolt the two bearing standards to the brackets on the legume box using six 5/16 x 3/4" carriage bolts, flat washers, lock washers and nuts. Align the bearing standards before tightening bolts. Loosely bolt the bearings to the outside of the bearing standards using the four 5/16" x 3/4" carriage bolts. Install the 29" shaft with the 17 tooth sprocket BETWEEN the bearings as shown in Figure 2. Install two wooden block chain tightener using 3/8" x 2-1/2" bolts, two flat washers, lock washer and nuts. Tighten the drive chains.

Step 6: Cut 5/8" I.D. clear plastic hose to 22" lengths. Eighteen are required. Install hoses on the grain cups first and then on legume box cups. Dipping the ends in a liquid soap solution (one part soap to one part water) will ease installation of the hoses.

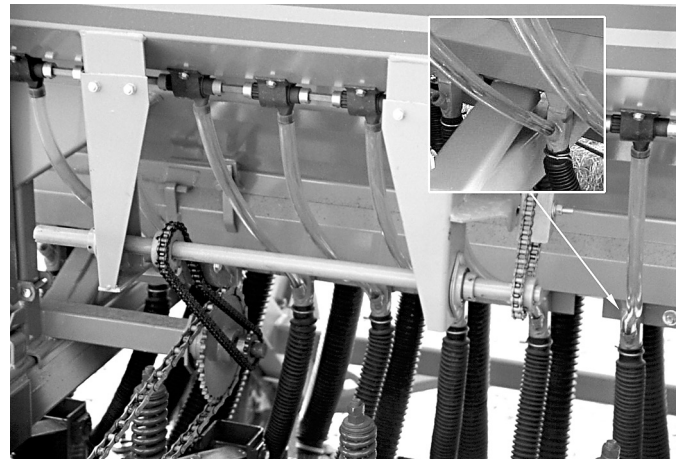

Completed drive shaft and seed tubes shown with standard hose connections. (See following page for completed drive shaft with optional drop tube assembly installed.)

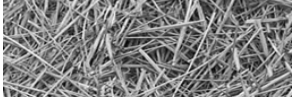

drop tube with seed tube connected

Completed drive shaft with optional drop tube assembly installed . Seed tubes are shown connected to the drop tubes. (See previous page for completed drive shaft and seed tubes shown with standard hose connections.)

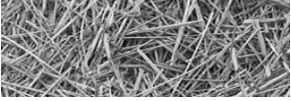

Legume Box (Option) Installation: Figure 1

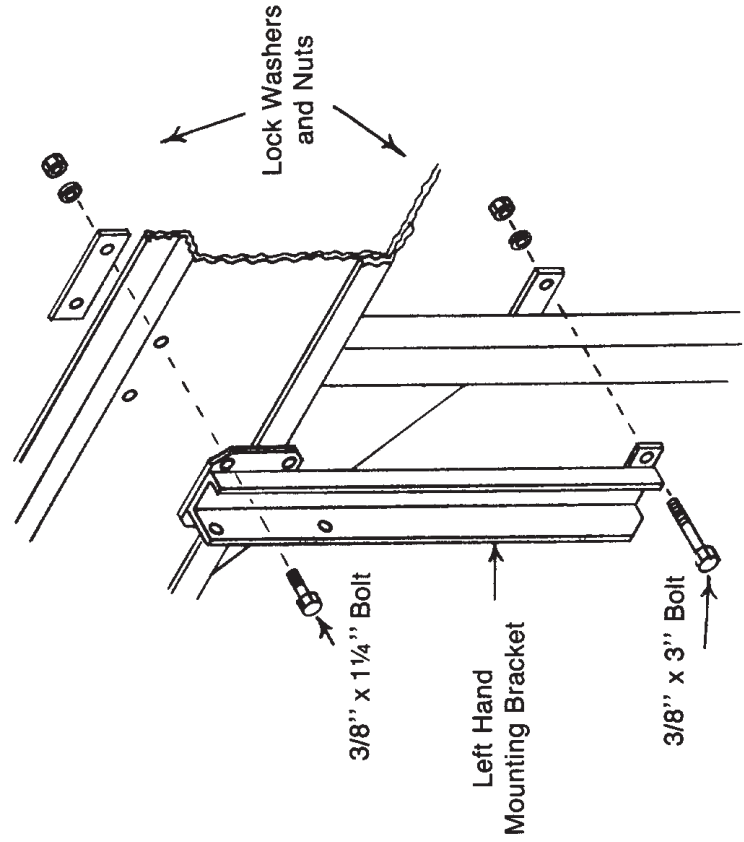
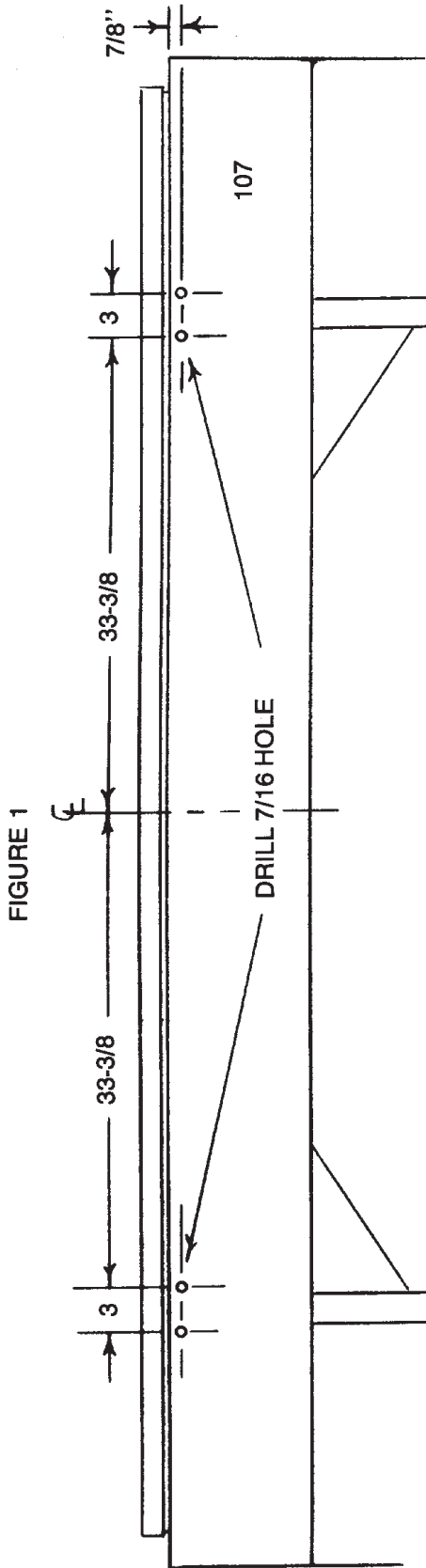

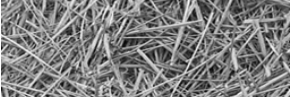

Legume Box (Option) Installation: Figure 2

FIGURE 2

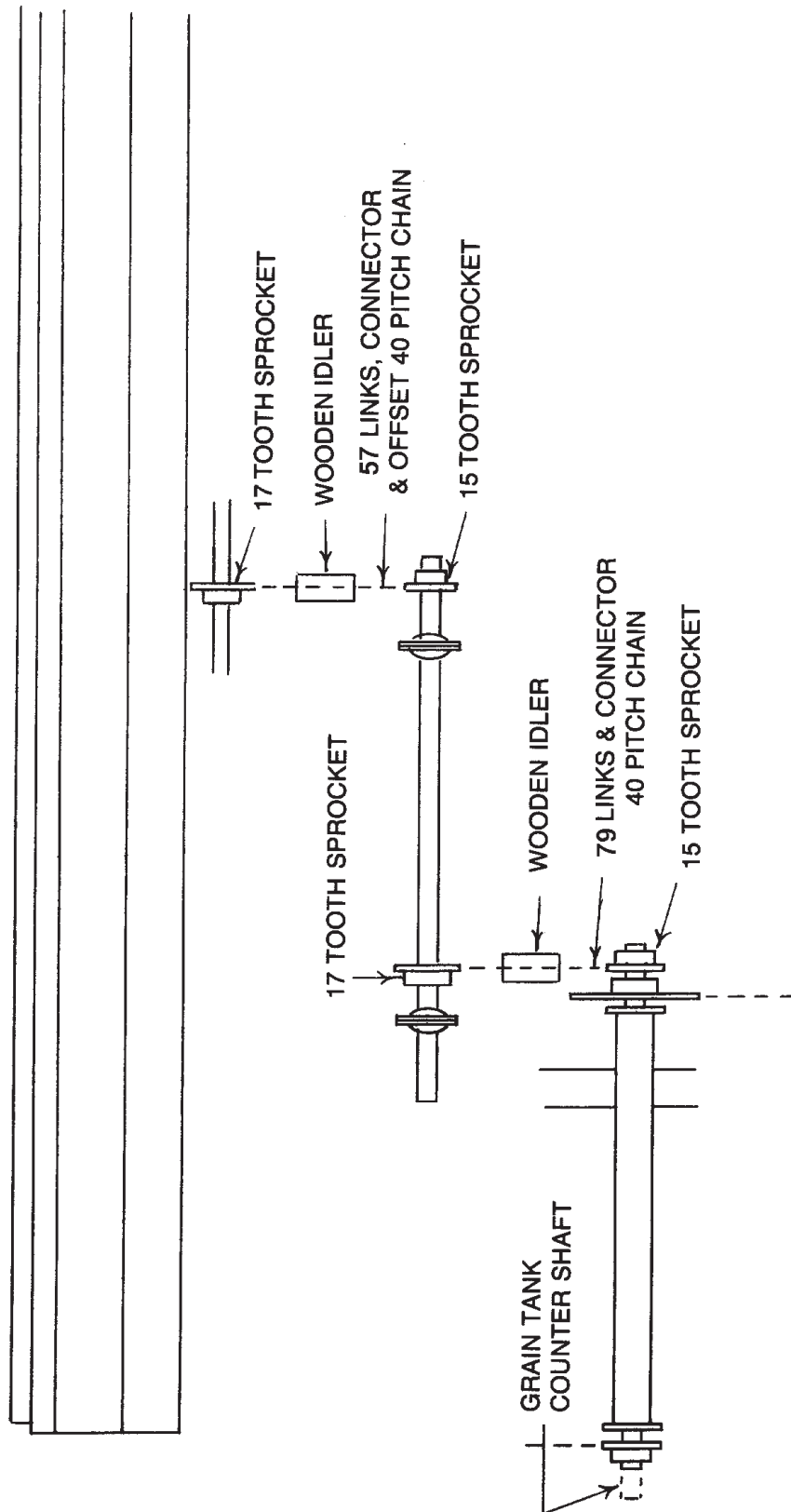

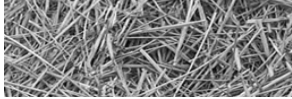

2.2 Legume Hopper Shipping Kit

PART	QTY.	DESCRIPTION
8700001	1	Mounting Bracket (1) Left Hand
8700002	1	Mounting Bracket (1) Right Hand
8700003	4	Mounting Straps 1/4 x 1-1/4 Flat
8700008	1	Bearing Standard (1) Right Hand
8700009	1	Bearing Standard (1) Left Hand
2000002	2	1" Bearing Insert w/Collar
2000703	4	52-MST-C2 Flangetts
2000016	2	Wood Blocks
8700011	1	1" Shaft 29" Long
1000111	1	4017 Sprocket 1" Bore
1000112	2	4015 Sprocket 1" Bore
6200010	3	1/4" x 1" Square Keys
1100232	1	#40 Chain 57 Links
1100246	1	#40 Chain 79 Links
1100224	2	#40 Connector Links
1100225	2	#40 Offset Links
3700129	18	5/8 I.D. Plastic Hose 22-1/2"
4800098	4	3/8" x 1-1/4" Bolts
4800156	4	3/8" x 3" Bolts
4800029	2	3/8" x 2-1/2" Bolts
4800003	4	3/8" x 1" Bolts
4900002	14	3/8" Nuts
5000019	14	3/8" Lock Washer
5000001	4	3/8" Flat Washer
4800153	10	5/16" x 3/4" Carriage Bolts
4900003	10	5/16" Nuts
5000022	10	5/16" Lock Washer

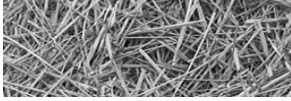

CHART FOR DRILLING LEGUMES AND SMALL GRASSES IN POUNDS PER ACRE

LEGUME BOX ATTACHMENT FOR 107 DRILL ON 7" SPACING

NOTCHES ON INDEX	LBS. / BU.																
	1	2	3	4	5	6	7	8	9	10	11	12	13	14	15	16	
ALFALFA; RED, ALSIKE, LADINO CLOVER; VETCH	62	2.2	4.7	7.7	10.7	13.6	17.0	20.4	23.9	27.3	30.9	31.7	37.9	41.3	44.7	47.6	50.6
SWEET CLOVER	64	2.3	5.1	8.4	12.4	17.4	22.5	26.4	30.9	37.1	41.6	46.7	51.2	56.3	59.6	63.0	66.4
BIRDSFOOT TREFLOIL	64	2.3	4.5	7.9	10.7	14.1	17.4	21.4	25.3	28.1	32.1	36.0	39.4	42.2	46.7	50.1	55.1
MILLIT, TIBBET CLOVER	60	2.1	4.9	7.7	10.7	14.3	17.4	21.2	26.1	28.5	30.9	35.5	39.4	42.8	46.7	51.0	55.9
UNHULLED SERICEA	36	1.1	2.8	4.5	6.8	9.6	11.8	14.6	17.4	20.3	23.1	26.4	28.7	31.5	33.8	36.0	40.5
UNHULLED LESPEDEZA	46	1.7	3.9	5.6	8.4	11.8	15.2	18.0	21.9	25.3	28.7	32.6	35.4	38.3	41.6	45.0	50.1
BAHIA GRASS	46	1.1	2.8	5.1	6.2	8.4	10.7	11.8	14.6	16.9	18.6	20.8	22.5	24.2	25.9	27.6	28.1
LOVEGRASS	64	2.3	5.1	7.9	11.3	16.3	20.3	24.2	28.7	32.6	36.6	42.2	46.7	51.2	55.1	57.9	60.2

SEED MIXTURES

SELECT THE SETTING FOR THE DESIRED QUANTITY OF EACH SEED.

ADD INDIVIDUAL SETTINGS.

EXAMPLE:	LBS/ACRE	NOTCH
ALFALFA	5	2
SWEET CLOVER	5	2
TIMOTHY	2	1
TOTAL		5

WHEN USING HALF SPEED DRIVE DIVIDE CHARTED RATES BY TWO. REPLACE 17 TOOTH SPROCKET ON COUNTERSHAFT WITH 35 TOOTH. (SEE MANUAL FOR DETAILS.)

DENSITY OF THE SAMPLES USED TO PREPARE THIS CHART ARE GIVEN IN THE FIRST COLUMN TO THE RIGHT OF THE CROP NAME IN POUNDS PER BUSHEL.

NOTCHES ON INDEX	LBS. / BU.																
	1	2	3	4	5	6	7	8	9	10	11	12	13	14	15	16	
TIMOTHY	50	1.7	3.9	6.2	9.6	12.9	16.9	20.9	24.8	28.1	32.6	37.1	40.5	44.4	46.7	49.5	54.6
SWITCHGRASS	55	2.3	4.5	6.8	9.6	12.4	15.8	18.6	20.8	24.2	28.1	30.9	33.8	37.1	39.9	42.2	47.8
FLAX SESAME	55	1.4	3.7	6.2	8.7	11.6	14.7	17.5	20.6	23.1	26.5	29.6	32.4	35.5	37.9	40.5	44.5
RAPE MUSTARD	53	1.7	4.2	7.4	10.2	12.9	16.4	19.2	22.5	25.6	28.2	31.8	34.9	37.7	40.5	43.3	45.9
ORCHARD GRASS	17		0.8	1.7	2.8	3.4	3.9	5.1	5.6	6.8	7.3	8.4	9.0	10.1	10.7	11.3	11.9
PERENNIAL RYEGRASS	31		2.3	3.4	5.6	7.3	9.0	10.7	11.8	13.5	15.2	16.9	18.6	20.8	21.9	23.1	24.8
FESCUE	27		1.1	2.8	3.9	5.6	6.8	8.4	9.6	11.3	12.4	13.5	15.2	16.9	18.0	19.1	21.9
COMMON BERMUDA GRASS		2.7	5.0	7.4	10.6	14.3	17.6	20.8	25.1								

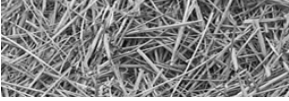

CHART FOR DRILLING LEGUMES AND SMALL GRASSES IN POUNDS PER ACRE

LEGUME BOX ATTACHMENT FOR 1000 DRILL ON 10" SPACING

NOTCHES ON INDEX	LBS. BU.	1	2	3	4	5	6	7	8	9	10	11	12	13	14	15	16
ALFALFA; RED, ASKINE, LADINO CLOVER; VETCH	62	1.5	3.3	5.4	7.5	9.5	11.9	14.3	16.7	19.1	21.6	22.2	26.5	28.9	31.3	33.3	35.4
SWEET CLOVER	64	1.6	3.5	5.9	8.7	12.2	15.8	18.5	21.7	26.0	29.2	32.7	35.9	39.4	41.8	44.1	46.5
BIRDSFOOT TREFOIL	64	1.6	3.2	5.5	7.5	9.9	12.2	15.0	17.7	19.7	22.5	25.2	27.6	29.6	32.7	35.1	38.6
MILLET, TIBET CLOVER	60	1.5	3.4	5.4	7.5	10.0	12.2	14.8	18.3	20.0	21.6	24.9	27.6	30.0	32.7	35.7	39.2
UNHULLED SERICEA	36	0.8	2.0	3.2	4.7	6.7	8.3	10.2	12.2	14.2	16.2	18.5	20.1	22.1	23.6	25.2	28.4
UNHULLED LESPEDEZA	46	1.2	2.8	3.9	5.9	8.3	10.6	12.6	15.4	17.7	20.1	22.9	24.8	26.8	29.2	31.5	35.1
BAHIA GRASS	46	0.8	2.0	3.5	4.3	5.9	7.5	8.3	10.2	11.8	13.0	14.6	15.8	16.9	18.1	19.3	19.7
LOVEGRASS	64	1.6	3.5	5.5	7.9	11.4	14.2	16.9	20.1	22.9	25.6	29.6	32.7	35.9	38.6	40.6	42.2

SEED MIXTURES

SELECT THE SETTING FOR THE DESIRED QUANTITY OF EACH SEED.

ADD INDIVIDUAL SETTINGS.

EXAMPLE:

ALFALF	LBS/ACRE	NOTCH
SWEET CLOVER	5	2
TIMOTHY	5	2
TOTAL	2	$\frac{1}{5}$

WHEN USING HALF SPEED DRIVE DIVIDE CHARTED RATES BY TWO. REPLACE 17 TOOTH SPROCKET ON COUNTERSHAFT WITH 35 TOOTH. (SEE MANUAL FOR DETAILS.)

DENSITY OF THE SAMPLES USED TO PREPARE THIS CHART ARE GIVEN IN THE FIRST COLUMN TO THE RIGHT OF THE CROP NAME IN POUNDS PER BUSHEL.

NOTCHES ON INDEX	LBS. BU.	1	2	3	4	5	6	7	8	9	10	11	12	13	14	15	16
TIMOTHY	50	1.2	2.8	4.3	6.7	9.1	11.8	14.6	17.3	19.7	22.9	26.0	28.4	31.1	32.7	34.7	38.2
SWITCHGRASS	55	1.6	3.2	4.7	6.7	8.7	11.0	13.0	14.6	16.9	19.7	21.7	23.6	26.0	28.0	29.6	33.5
FLAX SESAME	55	1.0	2.6	4.3	6.1	8.1	10.3	12.3	14.4	16.2	18.6	20.7	22.7	24.9	26.5	28.4	31.2
RAPE MUSTARD	53	1.2	2.9	5.2	7.1	9.0	11.5	13.4	15.8	17.9	19.8	22.3	24.4	26.4	28.4	30.3	32.2
ORCHARD GRASS	17		0.6	1.2	2.0	2.4	2.8	3.5	3.9	4.7	5.1	5.9	6.3	7.1	7.5	7.9	8.3
PERENNIAL RYEGRASS	31		1.6	2.4	3.9	5.1	6.3	7.5	8.3	9.5	10.6	11.8	13.0	14.6	15.4	16.2	17.3
FESCUE	27		0.8	2.0	2.8	3.9	4.7	5.9	6.7	7.9	8.7	9.5	10.6	11.8	12.6	13.4	15.4
COMMON BERMUDA GRASS		1.9	3.5	5.2	7.4	10.0	12.3	14.6	17.6								

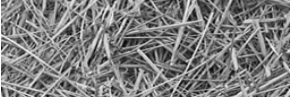

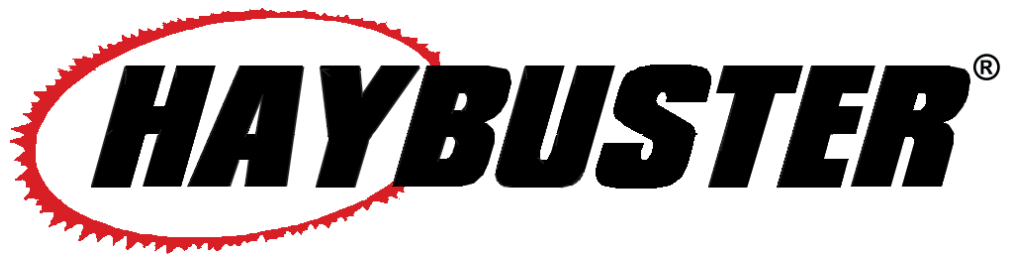
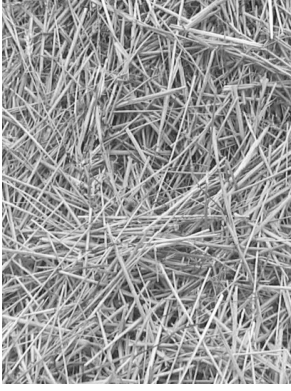

107/107C DRILL™ LEGUME BOX

Parts Reference

LEGUME BOX

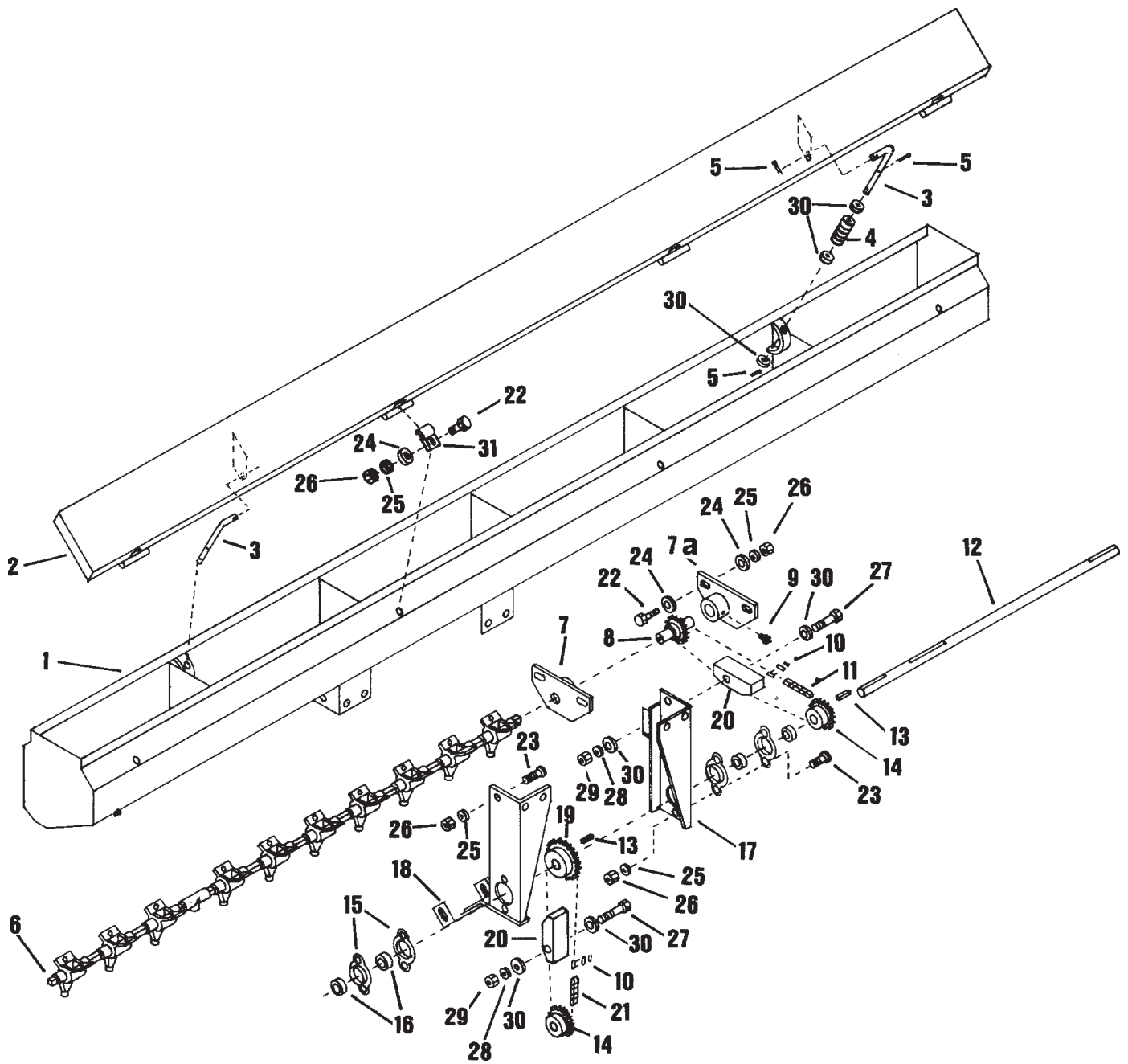

LEGUME BOX

ITEM	PART	QTY.	PART DESCRIPTION
1	8700004	1	Legume Box Weldment
2	8700005	1	Box Cover
3	8700006	2	Box Cover Spring Rod
4	6100046	2	Spring
5	4800127	6	Cotter Pin 1/8" x 1"
6	8700007	2	Shaft 3/8" Sq. x 50-3/4"
7	8700008	1	Bearing Right Hand
7A	8700009	1	Bearing Left Hand
8	8700010	1	Sprocket 17 Tooth
9	3800082	2	Zerk 1/4" Tapper
10	1100224	2	40NP Pitch Connector Link
11	1100232	1	53 Links 40NP Pitch Chain
12	8700011	1	Shaft 1" x 29"
13	6200010	4	1/4" x 1" Key
14	1000112	2	4015 Sprocket 1" Bore 1/4 KW
15	2000703	4	2 Hole Flangette
16	2000002	2	1" Bearing with Lock Collar
17	8700012	1	Bracket Left Hand
18	8700013	1	Bracket Right Hand
19	1000111	1	4017 Sprocket 1" Bore 1/4 KW
20	2000016	2	Wood Block Idler
21	1100233	1	77 Links 40NP Pitch Chain
22	4800013	8	5/16" x 1" Hex Head Bolt
23	4800153	10	5/16" x 3/4" Carriage Bolt
24	5000023	12	5/16" Flat Washer
25	5000022	18	5/16" Lock Washer
26	4900003	18	5/16" Hex Nut
27	4800029	2	3/8" x 2-1/2" Hex Head Bolt
28	5000019	2	3/8" Lock Washer
29	4900002	2	3/8" Hex Nut
30	5000001	10	3/8" Flat Washer
31	8700014	4	Hinge
32	8700015	2	Seed Cup Long Gang (Not Shown)
33	8700016	2	Seed Cup Short Gang (Not Shown)

SEED INDEX ASSEMBLY LEGUME BOX

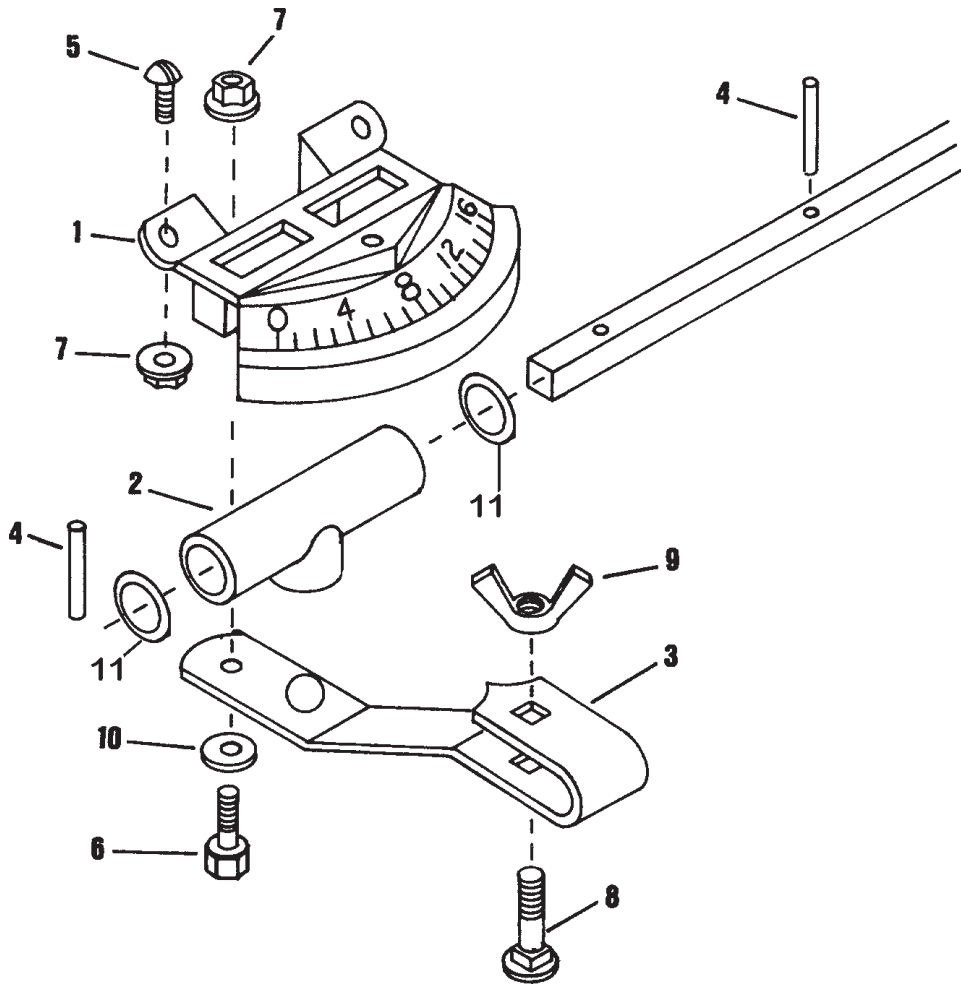

ITEM	PART	QTY.	PART DESCRIPTION
1	7500183	1	Seed Index Meter
2	7500184	1	Shifter Spool
3	7500185	1	Shifter Arm
4	4800212	2	Rolled Pin 5/32" x 3/4"
5	4800213	3	Cap Screw 1/4" x 5/8" Pan Head Machine Screw
6	4800024	1	1/4" x 3/4" Bolt
7	4900040	4	1/4" Flange Nut
8	4800214	1	Carriage Bolt 1/4" x 1"
9	4900041	1	1/4" Wing Nut
10	5000035	1	1/4" Flat Washer
11	5000118	2	WASH\FLAT\SPCL\14MM\.5MM\20MMOD

CUP ASSEMBLY LEGUME BOX

ITEM	PART	QTY.	PART DESCRIPTION
1	7500177	1	Feed Roller
2	7500178	1	Snap Ring
3	7500179	1	Feed Roller Washer
4	7500180	1	Feed Cup w/Washer & Ring
5	4800154	2	1/4" X 1/2" Flat Head Slotted Screw
6	4900040	2	1/4" Flange Nut
7	7500181	1	Gate
8	7500182	2	Collar
9	4800211	2	Set Screw 1/4" x 5/16"
10	3700129	1	5/8" I.D. Hose x 22"
11	8700016	1	Plug for 10" Spacing

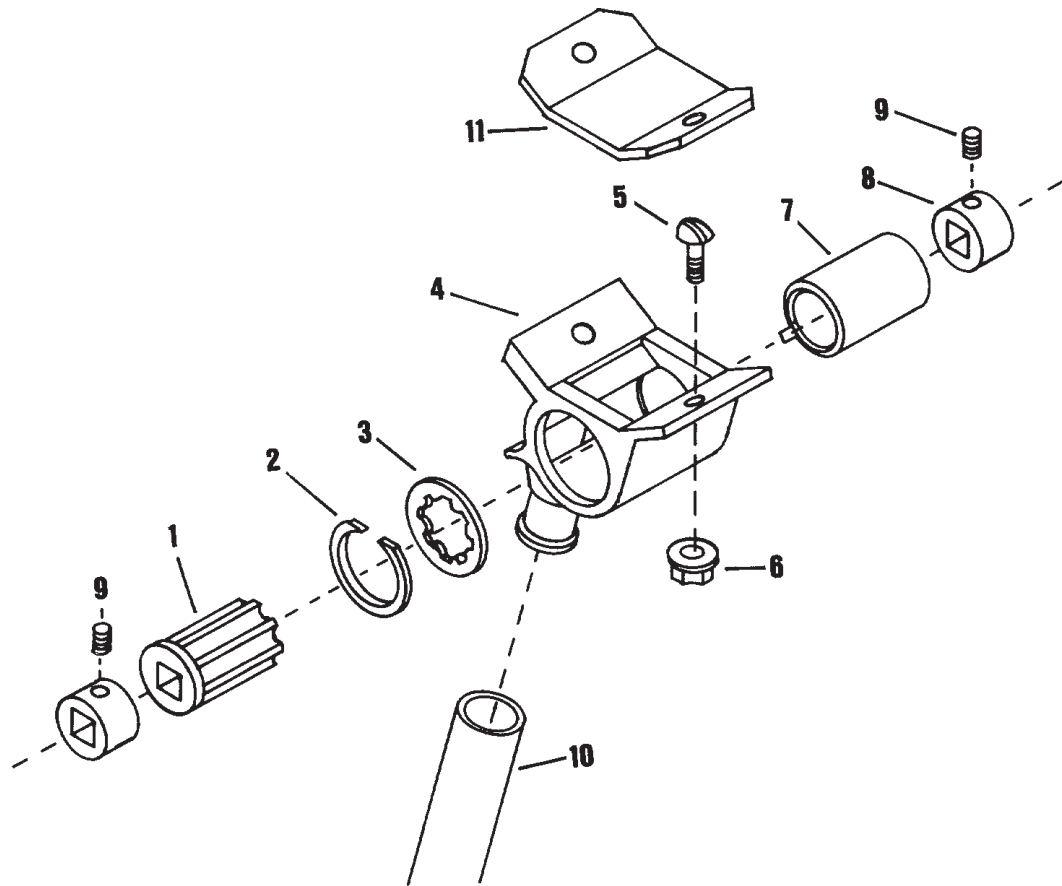

LEGUME DROP TUBE ASSEMBLY

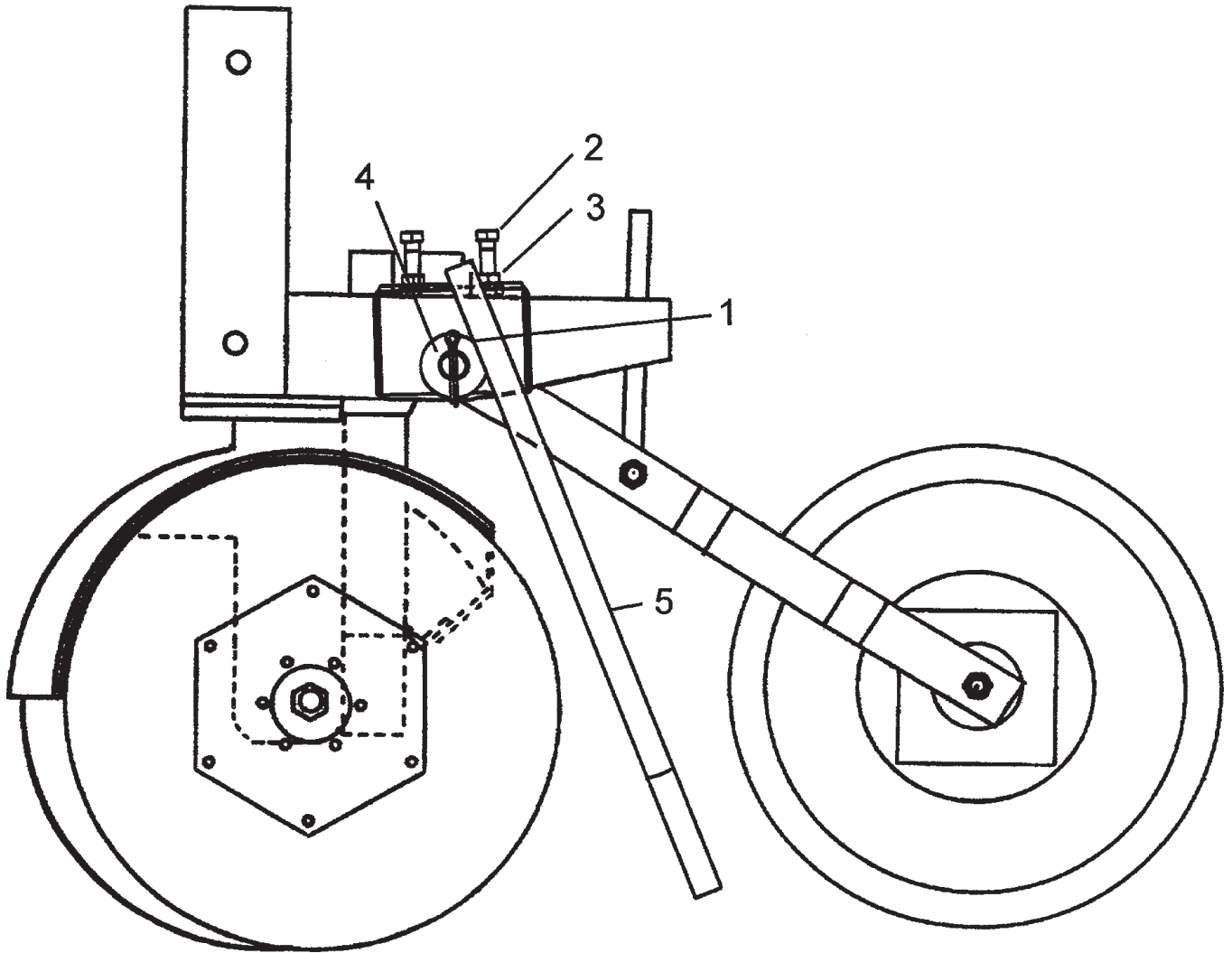

LEGUME DROP TUBE ASSEMBLY

ITEM	PART	QTY.	PART DESCRIPTION
	8400631		TUBE\DROP\LEGUME\KIT\1BEND\107\PER ROW
1	4800050		PIN\COT\3/16 X 1-1/2
1A	4800218	1	BOLT\HEX\5/8X5-1/2
1B	4900107	1	NUT\NYLCK\5/8\NC
2	4800098	2	BOLT\HEX3/8 X 1-1/4\NC
3	4900026	2	NUT\JAM\3/8\NC
4	5000002	1	WASH\FLAT\5/8
5	8400630	1	BRKT\TUBE\DROP\LEGUME\1BEND\107

NOT SHOWN

3700127 2 FT. HOSE\PVC\5/8ID\CLEAR\BULK

LEGUME DROP TUBE ASSEMBLY (107C)

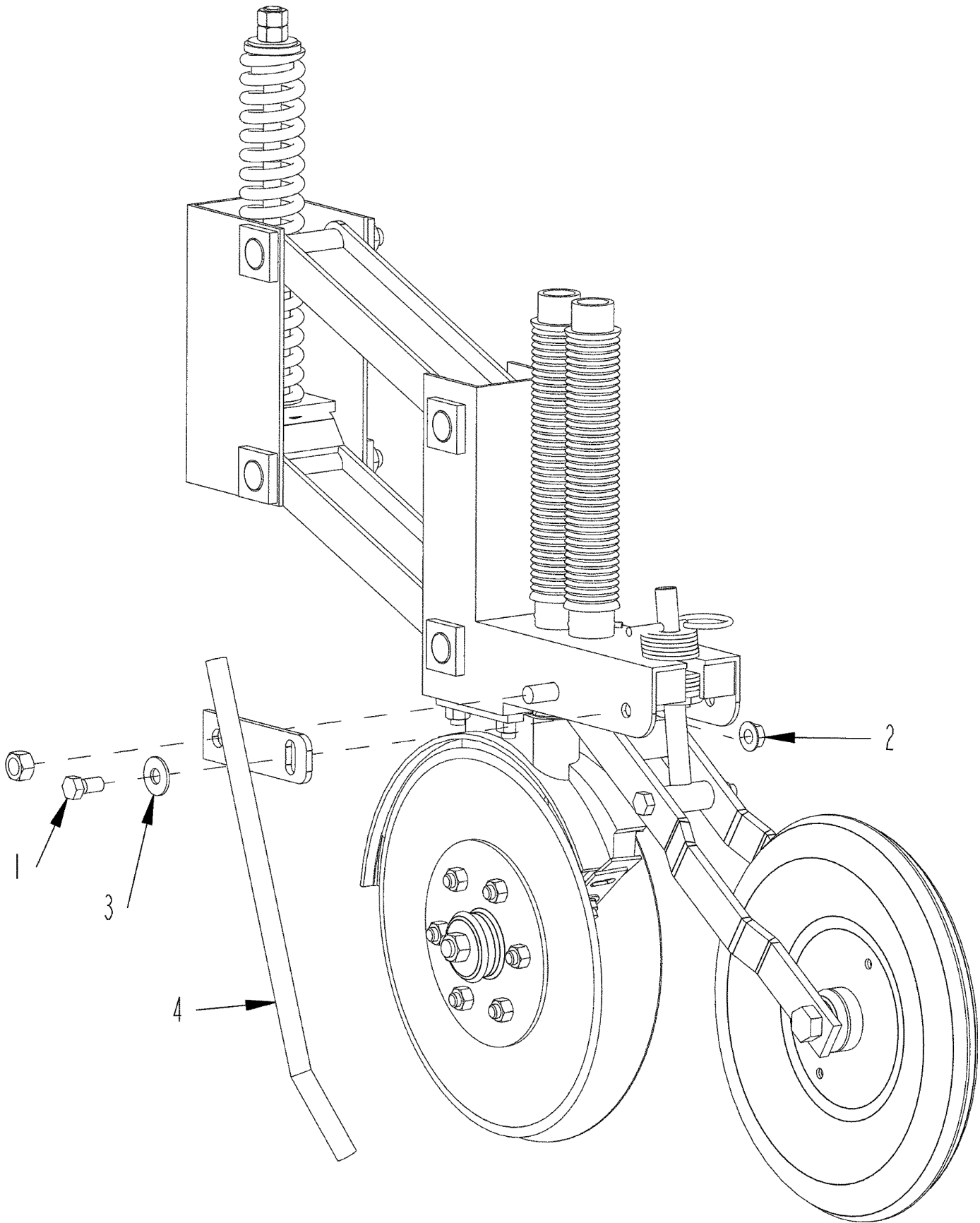

LEGUME DROP TUBE ASSEMBLY (107C)

ITEM	PART	QTY.	PART DESCRIPTION
1	4800018	1	BOLT\HEX\1/2X1-1/4
2	4900133	1	NUT\FLG\1/2\NC
3	5000004	1	WASH\FLAT\1/2
4	8400695	1	BRKT\TUBE\DROP\LGM\CASTRUN
	8400856		TUBE\DROP\LGM\KIT\SINGLE

NOT SHOWN

	3701371	1	HOSE\PVC\5/8IDX53\CLEAR
	7500107	1	CLAMP\HOSE\1-1/4\WORM\SS

MOUNTING BRACKET

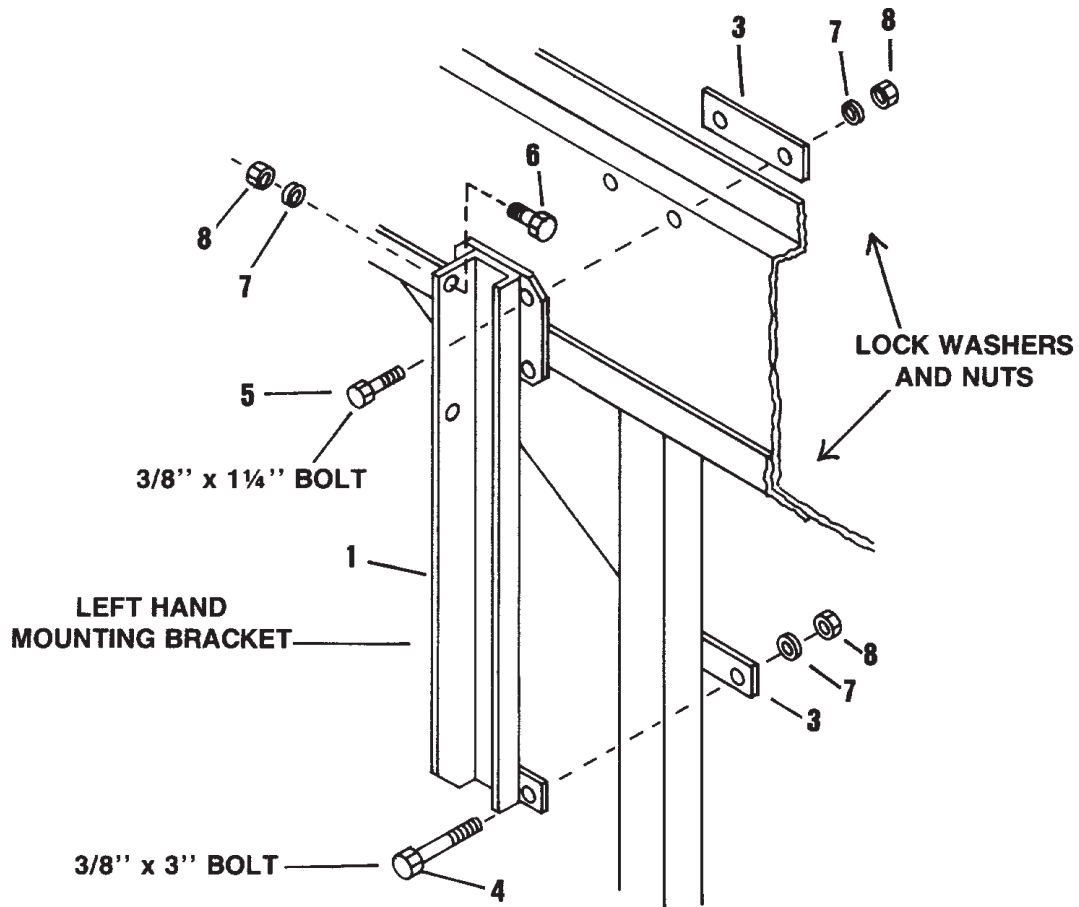

ITEM	PART	QTY.	PART DESCRIPTION
1	8700001	1	Mounting Bracket Left Hand
2	8700002	1	Mounting Bracket Right Hand (Not Shown)
3	8700003	4	Strap
4	4800156	4	3/8" x 3" Hex Head Bolt
5	4800098	4	3/8" x 1-1/4" Hex Head Bolt
6	4800003	4	3/8" x 1" Hex Head Bolt
7	5000019	12	3/8" Lock Washer
8	4900002	12	3/8" Hex Nut

