

KNIGHT

TOW TYPE BOX SPREADERS

PARTS MANUAL

FOR

MODEL 1030 & 1040

TABLE OF CONTENTS

Using This Listing	1
Apron & Drive System	2-3
Beater & Drive System	4-5
Upper Beater (<i>Option</i>)	6-7
Plastic Floor	8-9
Undercarriage <i>single axle (1030 only)</i>	10-11
Undercarriage <i>tandem axle (1030 only)</i>	12-15
Undercarriage <i>tandem axle (1040 only)</i>	16-19
50:1 Gearcase (<i>Apron drive</i>)	20-21
Right Angle Gearcase parts (<i>Beater drive</i>) ..	22-23
Hydraulic End Gate	24-25
PTO, 540 RPM (<i>1-3/8" 6 spline</i>)	26-27
PTO, 1000 RPM (<i>1-3/8" 21 spline</i>)	28-29
Jackstand	30
Decals and Paint	31
U-Joint Repair	32
Hardware Listing	33-34
Part Number Index	35-37

Catalog P/N 005759 Unit Serial Number: ____

Operator Instruction Manual For This Unit Is #005739

G:\DOCUMENT\MANUALS\PARTSMAN\1030-TOW.WPD

Rev. 030399

ABBREVIATIONS

Assy	Assembly
A/R	As Required
B	Bolt
Brg	Bearing
BSN	Before Serial Number
Btm	Bottom
C-Bolt	Carriage Bolt
Cttr	Cotter
CV	Constant Velocity
Deg	Degree
Dia	Diameter
ea	Each
eq or Equiv	Equivalent
Fln	Flanged Lock Nut
Fw	Flat Washer
Ga	Gauge
Gr or Grd	Grade
Hd	Head
Hyd	Hydraulic
ID	Inside Diameter
Ill or Illus	Illustration
Ind	Indicator
Kw	Keyway
LH	Left Hand
Ln	Lock Nut
Lw	Lock Washer
Mtg Hrd	Mounting Hardware
NC	National Coarse
NF	National Fine
NPT	National Pipe Thread
OD	Outside Diameter
Pc(s)	Piece(s)
PD	Pitch Diameter
PTO	Power Takeoff (shaft)
Q or Qty	Quantity
Reg Mach	Regular Machine
RH	Right Hand
SN	Serial Number
Spk, or Spkt or Sprkt	Sprocket
Sq	Square
SS	Stainless Steel
SSB	Stainless Steel Bolt
St	Straight
Std	Standard
STS	Self Tapping Screw
UASN	Used After Serial Number
UBSN	Used Before Serial Number
W	With
W/O	With Out

USING THIS SERVICE PARTS LISTING

This listing uses a number indentation system to specify the parts of an assembly. Any number which is indented to the right, indicates that it is a component of the item to the upper left. Example:

<u>Part no</u>	<u>Qty</u>	<u>Description</u>
102-AAA	#	Assembly A
102-BBB	#	Sub-Assembly B
(Component of A)		
140-xxx	#	Sub-Component of B
140-xxx	#	Sub-Component of B
102-CCC	#	Sub-Assembly C
(Component of A)		
etc.		

Using this system, the subassemblies and their components are included if an **Assembly** is ordered. Similarly, the components of a subassemblies are included if a subassembly is ordered.

The quantity (Qty) associated with an assembly, represents the number of times an assembly could be shown in the drawing. The subassembly quantity however, is the number of times a subassembly is used to build one assembly. Similarly, the component quantity refers to the number of times a given component is found in one subassembly.

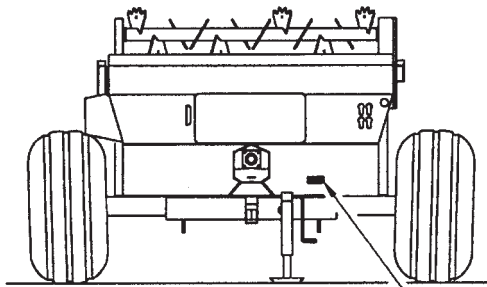

SERIAL NUMBER LOCATION

FIGURE A

MODEL AND SERIAL NUMBER INFORMATION is located near the front left hand corner (Fig. A). The model number, serial number and part number should be known when asking service personnel for parts.

If you cannot find the part you need, be as descriptive as possible when placing an order:

Sprockets: give the bore size, number of teeth, and size of keyway.

Roller chain: give the size of chain (stamped on the side of each link) and number of links.

Shafting: give the diameter, length, and quantity and size of keyways.

Hardware is generally not included with parts. If you need any hardware, check the size, the length, and the grade (Fig. B), then check the hardware list in this manual for the part numbers.

All hex head bolts are grade 5, and nuts are grade B unless otherwise stated.

The hardware listing also includes listings for zerks, cotter pins, set screws, and roller chain links.

The illustrations in this manual are meant to be used only as a guide for identifying parts and locating their relative positions.

BOLT GRADES



GRADE

2

GRADE

5

GRADE

8

BOLT HEAD GRADE MARKING

0072

APRON & DRIVE SYSTEM

1030/1040-TOW R 030399

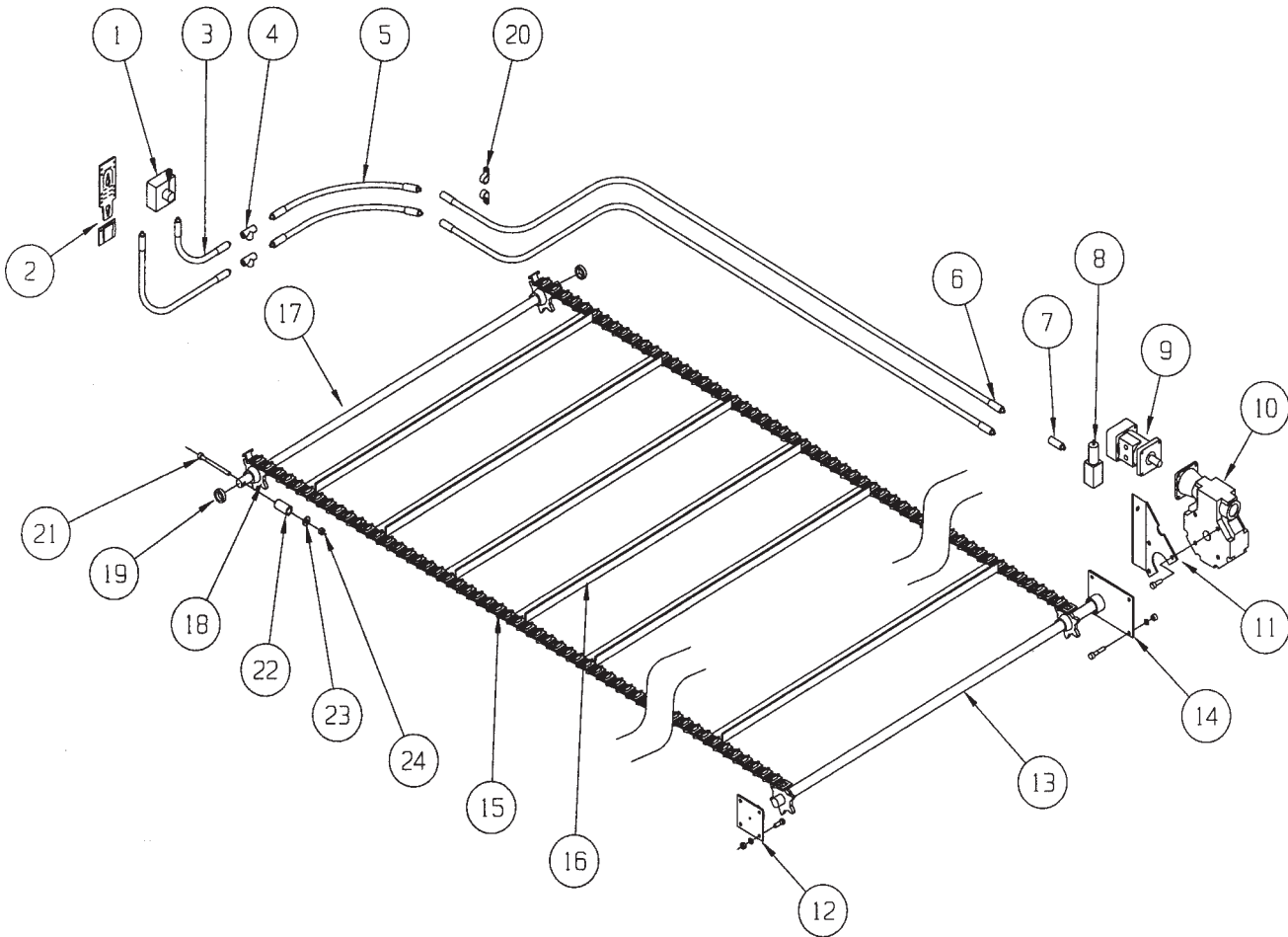

KNIGHT MANUFACTURING CORP. PO BOX 167 BROADHEAD, WI 53520
OFFICE: (608) 897-2131 PARTS/SERVICE: (608) 897-2125 FAX: (608) 897-2561

APRON & DRIVE SYSTEM

1030/1040-TOWR030399

REF	PART NO	QTY	DESCRIPTION
1	173-262	1	Flow Control Valve
2	300053	1	Flow Control Mount Kit
	136-699	2	Mount Bracket Blank
	102-374	1	SMV Socket Assy.
	172-986	2	¼" x 2" Cap Screw
	170-124	2	¼" Lock Washer
	170-125	2	¼" Nut
3	173-294	2	Hydraulic Hose: ½" x 60"
4	170-859	2	Service "Tee" Fitting; ½"
5	173-295	2	Hydraulic Hose; ½" x 100"
6	173-293	2	Hydraulic Hose; ½" x 189" (1030 only)
	173-289	2	Hydraulic Hose; ½" x 210" (1040 only)
7	173-290	1	Line Check Fitting ½" JIC x ½" FM
8	173-261	1	Relief Valve; Mtg Hrd: 5/16" x 2-1/2" Bolt, Lw (4ea)
9	173-260	1	Motor; 10 cu. in. 4-Bolt; 1" sft; Mtg Hrd: 3/8" x 1" socket head cap screw (4ea)
10	136-626	1	Gearbox 50:1, LH; Mtg Hrd: ½" x 1 ½" Bolt & Lw
11	136-622	1	Torque Mount Plate; Mtg Hrd: ½" x 1 ½" Bolt, Lw, Nut (1ea), Fw (2ea)
12	102-449	1	Apron Bearing Assy. (Left) ; Mtg Hrd: ½" x 1 ½" Bolt, Lw, Nut (4ea)
	170-318	1	Bronze Bushing
	170-865	1	Zerk, Straight
13	102-448	1	Apron Drive Shaft Assy.
14	102-450	1	Apron Bearing Assy; (right); Mtg Hrd: ½" x 1 ½" Bolt, Lw, Nut (4ea)
	170-318	2	Bronze Bushing
	170-865	1	Zerk, Straight
15	170-448	230	T-Bar Link (1030 only)
		272	T-Bar Link (1040 only)
16	103-520	19	Apron Slat Assy.(1030 only)
		22	Apron Slat Assy.(1040 only)
17	136-582	1	Apron Idler Shaft
18	130-484	2	Idler Sprocket
19	136-546	2	Spacer
20	171-561	2	Hose Clamp; Mtg Hrd: 5/16" x 3/4" Bolt, Fln
21	170-504	2	Apron Bolt ½" x 8 ½"
22	170-500	2	Spring, 5/8"ID x 2 ½"
23	170-040	2	Flat Washer ½"
24	170-042	2	Lock Nut

An asterisk (*) at the end of a part number (XXX-XXX*) indicates that the part is no longer used in production for this application. Superscript letters (XXX-XXX^a) refer to footnotes and/or illustration boxes.

BEATER & DRIVE SYSTEM

1030/1040-TOW R030399

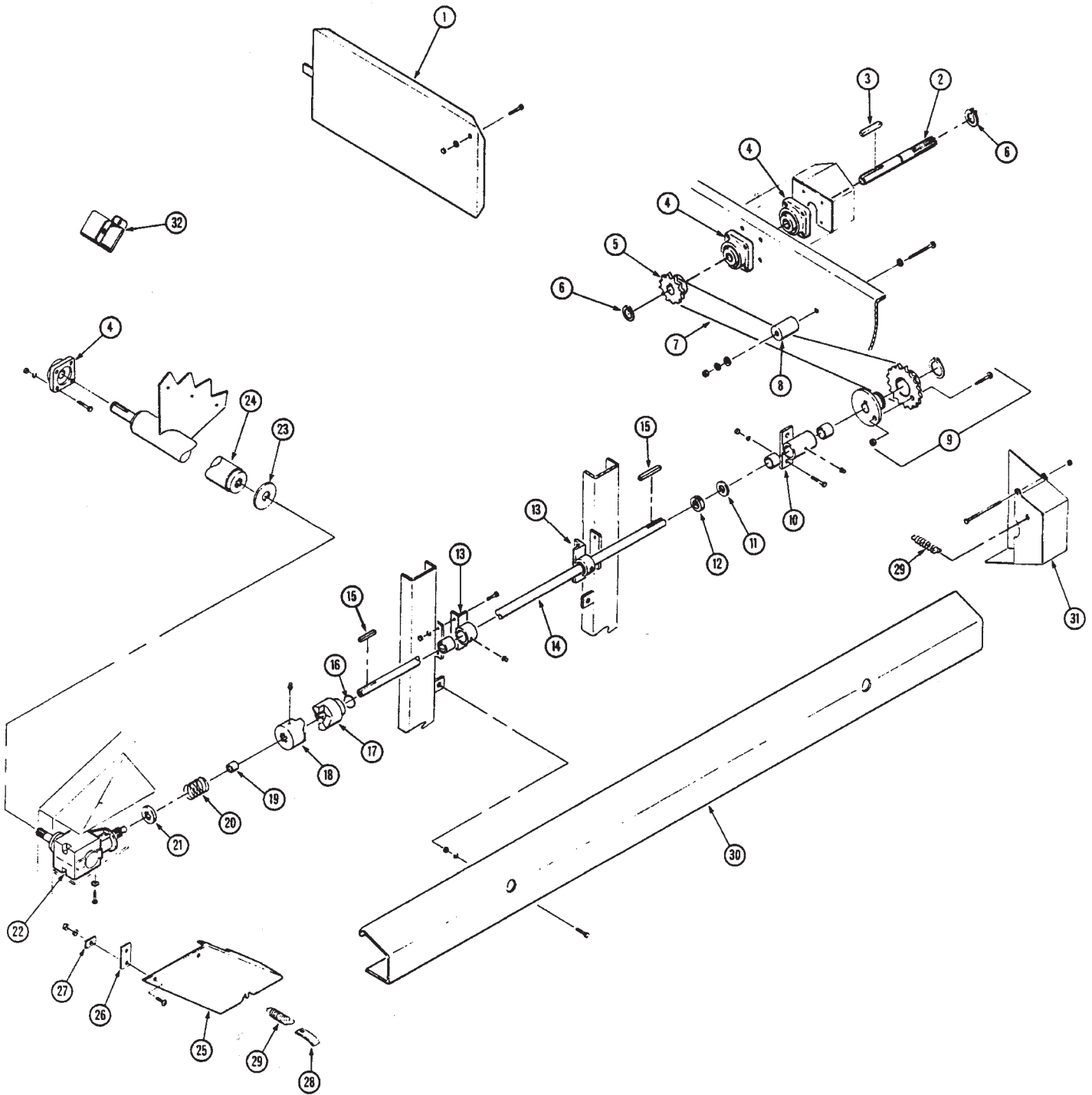

KNIGHT MANUFACTURING CORP. PO BOX 167 BROADHEAD, WI 53520
OFFICE: (608) 897-2131 PARTS/SERVICE: (608) 897-2125 FAX: (608) 897-2561

BEATER DRIVE SYSTEM

1030/1040-TOW R030399

REF	PART NO	QTY	DESCRIPTION
1	102-461	1	Front Shield Assembly; Mtg Hrd: 3/8" x 1/8" Bolt, Fw, Ln (1ea)
2	134-670	1	Input Shaft 1 3/8" x 13 1/2"
3	171-409	1	Key; 3/8" sq x 1 3/4"
4	170-000	3	Bearing; 1 3/8" Roller; Mtg Hrd: 1/2 x 1 1/2 Bolt, Lw, Nut (4ea)
5	136-630	1	Sprocket; 60-B-24 (540 rpm)
	132-128	1	Sprocket; 60-B-13 (1000 rpm)
6	170-499	2	Ring, Snap; 1 3/8" external
7	172-828	1	Roller Chain; 60-1-130 p. (540 rpm)
	173-356	1	Roller Chain; 60-1-123 p. (1000 rpm)
8	170-086	1	Wood Tightener Block; Mtg Hrd: 1/2" x 4" Bolt, Lw, Nut (1ea), Fw (2ea)
9	173-258	1	Shear Pin Sprocket Assembly
	170-142	1	Retaining Ring; 2" external
	173-257	1	Sprocket with Bushing; 60-B-27
	173-258	1	Hub
	170-263	1	Shear Bolt; 5/16" x 1 1/4" grade 5
	170-028	1	Lock Nut; 5/16"
10	102-454	1	Front Transfer Shaft Bearing; Mtg Hrd: 3/8" x 1" Bolt, Lw, Nut (2ea)
	170-171	2	Bronze Bushing
	170-023	1	Zerk, Straight
11	136-561	1	Thrust Washer
12	173-370	1	Collar, Shaft, (Weld on) 1 1/4"
	173-264 ^A	1	Lock Collar 1 1/4"
13	102-455	2	Transfer Shaft Bearing; Mtg Hrd: 3/8" x 1" Bolt, Lw, Nut (2ea)
	170-171	1	Bronze Bushing
	170-023	1	Zerk, Straight
14	136-611	1	Transfer Shaft ; 1 1/4" x 168 5/8 long (1030 only)
	136-685	1	Transfer Shaft ; 1 1/4" x 192 5/8 long (1040 only)
15	170-627	2	Key; 5/16" sq x 1 3/4"
16	173-368	1	Snap Ring, 1 1/4" internal
17	136-642	1	Clutch Jaw; 5/16" keyway
18	136-643	1	Clutch Jaw; Splined
	170-023	1	Zerk, Straight
19	173-369	1	Bushing; Bronze
	173-266 ^A	1	Bushing; Garlock
20	173-371	1	Spring, Compression, 4 1/4" Long
	173-263 ^A	1	Spring, Compression, 6 1/2" Long
21	136-681	1	Spring Stop Plate
22	136-625	1	Gearcase (right angle); Mtg Hrd: 1/2" x 1 1/2" Bolt, Fw, Lw (4ea)
23	136-682	1	Plastic Trash Guard
24	102-447	1	Beater Assembly
	101-449	1	Plug, Beater, RH Splined
	101-446	1	Plug, Beater, LH
	136-574	5	LH Paddle
	136-575	5	RH Paddle
25	136-676	1	Gearbox Shield; Mtg Hrd: 1/4" x 3/4" Pan Head Bolt, Lw, Nut (2ea hinge)
26	136-646	2	Belt Hinge
27	136-645	4	Hinge Backer Plate
28	133-552	1	Spring Handle
29	170-110	2	Spring
30	136-615	1	Transfer Shaft Shield 162" long (1030 only); Mtg Hrd: 5/16" x 1" Bolt, Fw, Fin
	136-666	1	Transfer Shaft Shield 185 1/4" long (1040 only); Mtg Hrd: 5/16" x 1" Bolt, Fw, Fin
31	102-453	1	Shield; Transfer Shaft / Shear Sprocket; Mtg Hrd: 3/8" x 5" Bolt, Ln
32	136-592	1	Stub Shaft Shield (used with no upper beater option)

A: Use before Serial Number (1030-166), (1040-198).

UPPER BEATER PARTS

1030/1040-TOW R030399

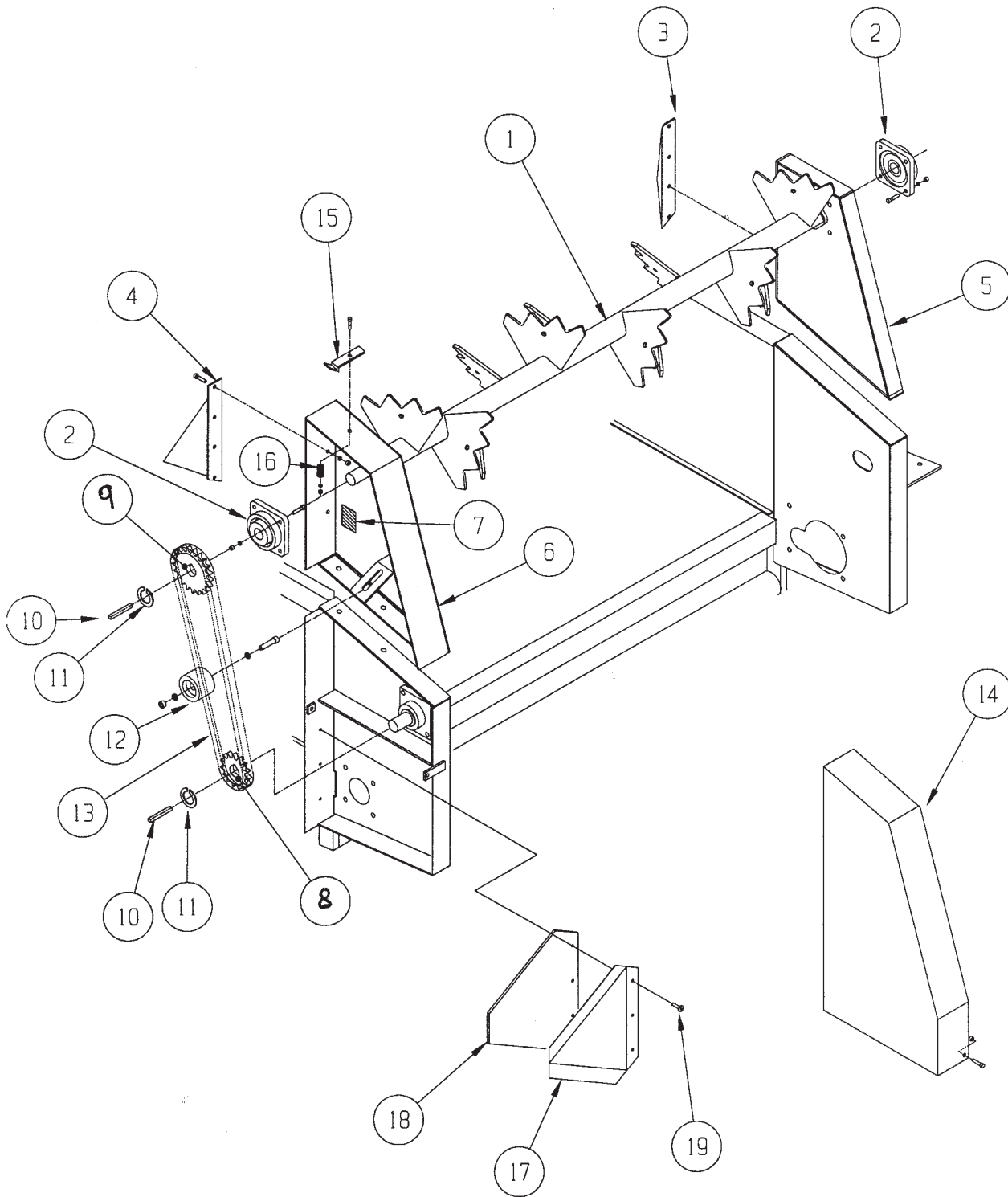

KNIGHT MANUFACTURING CORP. PO BOX 167 BROADHEAD, WI 53520
OFFICE: (608) 897-2131 PARTS/SERVICE: (608) 897-2125 FAX: (608) 897-2561

UPPER BEATER PARTS

1030/1040-TOW R030399

REF	PART NO	QTY	DESCRIPTION
1	102-463	1	Beater Assembly
	136-678	12	Paddle
	136-673	1	LH Plug
	136-674	1	RH Plug
2	170-000	2	Bearing; 1 $\frac{3}{8}$ "; Mtg Hrd: $\frac{1}{2}$ " x 1 $\frac{1}{2}$ " Bolt, Lw, Nut (4ea)
3	136-631	1	Deflector (<i>right side</i>); Mtg Hrd: $\frac{5}{16}$ " x $\frac{3}{4}$ " Bolt, Lw, Nut
4	136-632	1	Deflector (<i>left side</i>); Mtg Hrd: $\frac{5}{16}$ " x $\frac{3}{4}$ " Bolt, Lw, Nut
5	102-466	1	Top Beater Panel (<i>right side</i>) 3/8" x 1 1/4" Bolt, Lw, Nut (3 ea) Fw (6 ea)
6	102-467	1	Top Beater Panel (<i>left side</i>) 3/8" x 1 1/4" Bolt, Lw, Nut (3 ea) Fw (6 ea)
7	173-078	1	Decal (<i>Danger shield missing</i>)
8	136-629	1	Sprocket; 60-B-21
9	136-628	1	Sprocket; 60-B-15
10	170-410	2	Key; $\frac{3}{8}$ "sq x 2"
11	170-499	2	Retaining Ring; 1 $\frac{3}{8}$ " external
12	134-155	1	Tightener Block; Mtg Hrd: $\frac{3}{8}$ " x 2 $\frac{1}{2}$ " Bolt, Lw, Nut (1ea), Fw (2ea)
13	173-292	1	Roller Chain; 60-1-82 P.
14	136-695	1	Top Beater Shield; Mtg Hrd: $\frac{5}{16}$ " x $\frac{3}{4}$ " Bolt, Fln (2ea)
15	136-681	1	Shield Latch; Mtg Hrd: $\frac{5}{16}$ " x 1 $\frac{3}{4}$ " Bolt, Fw, Fln
16	170-345	1	Latch Spring
17	170-893	1	Decal, SMV (Mount with 173-355 "3M Super 90 adhesive)
18	136-607	1	Plastic SMV Mount
19	173-391	3	Rivet

An asterisk (*) at the end of a part number (XXX-XXX*) indicates that the part is no longer used in production for this application. Superscript letters (XXX-XXX^a) refer to footnotes and/or illustration boxes.

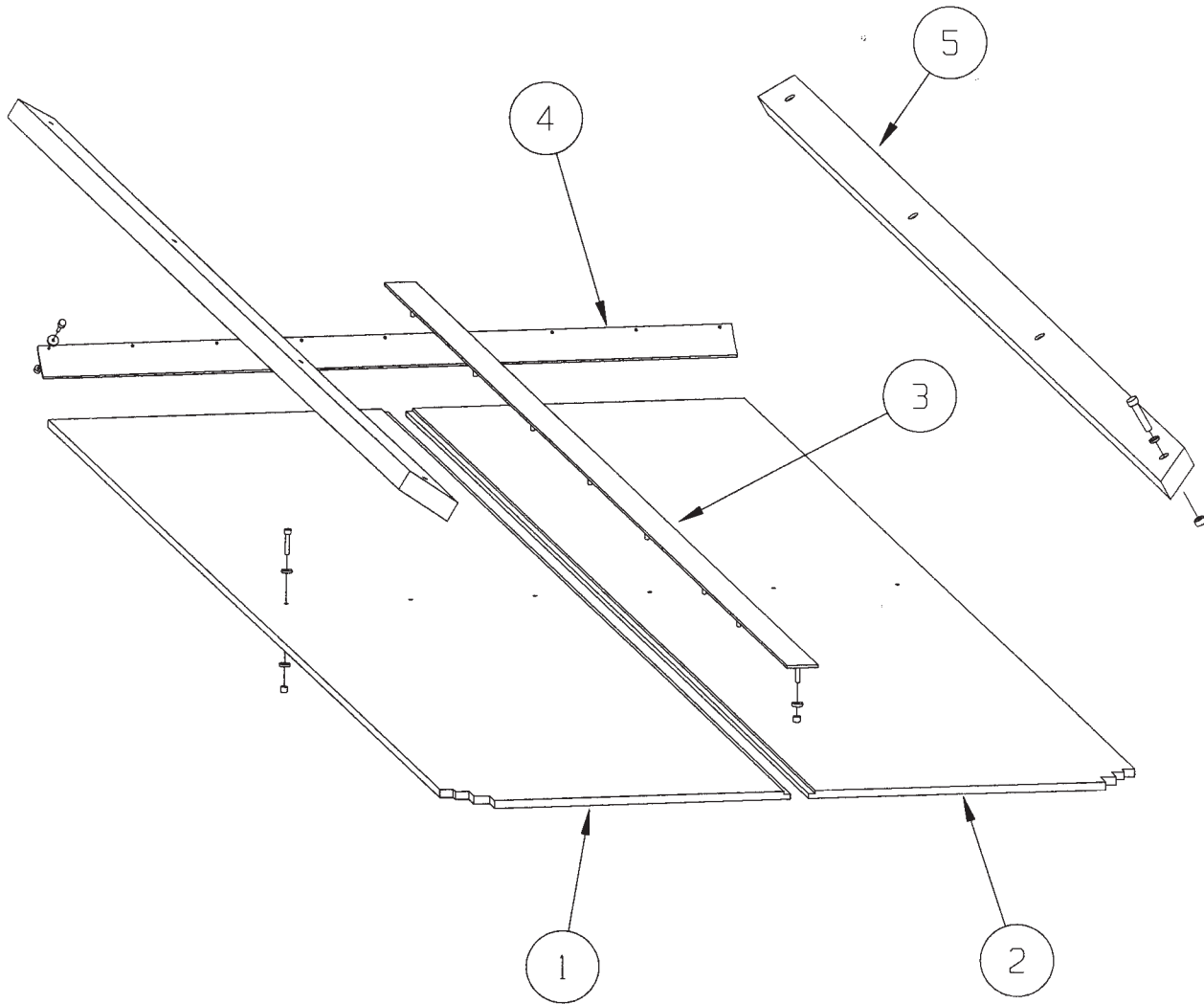

KNIGHT MANUFACTURING CORP. PO BOX 167 BROADHEAD, WI 53520
OFFICE: (608) 897-2131 PARTS/SERVICE: (608) 897-2125 FAX: (608) 897-2561

PLASTIC FLOOR AND SIDE RAILS

1030/1040-TOW R030399

REF	PART NO	QTY	DESCRIPTION
1	136-624	1	Floor Panel (<i>left side, 1030 only</i>)
	136-656	1	Floor Panel (<i>left side, 1040 only</i>); Mtg Hrd: 5/16" x 1 1/4" Bolt, Fln (6ea) , Fw (12ea)
2	136-623	1	Floor Panel (<i>right side, 1030 only</i>)
	136-657	1	Floor Panel (<i>right side, 1040 only</i>); Mtg Hrd: 5/16" x 1 1/4" Bolt, Fln (6ea) , Fw (12ea)
3	102-460	1	Center Hold Down Assy. (<i>1030 only</i>); Mtg. Hrd: 5/16" Fw, Fln (8ea)
	102-462	1	Center Hold Down Assy. (<i>1040 only</i>); Mtg. Hrd: 5/16" Fw, Fln (10ea)
4	136-706	1	Front End Belt; Mtg Hrd: 1/4" x 7/8" bolt, Fw, Nut
5	136-635	2	Plastic Side Rail (<i>1030 only</i>); Mtg Hrd: 5/8" x 2" Bolt, Fln, 5/16" Fw (6ea)
	136-636	2	Plastic Side Rail (<i>1040 only</i>); Mtg Hrd: 5/8" x 2" Bolt, Fln, 5/16" Fw (6ea)

An asterisk (*) at the end of a part number (XXX-XXX*) indicates that the part is no longer used in production for this application. Superscript letters (XXX-XXX^A) refer to footnotes and/or illustration boxes.

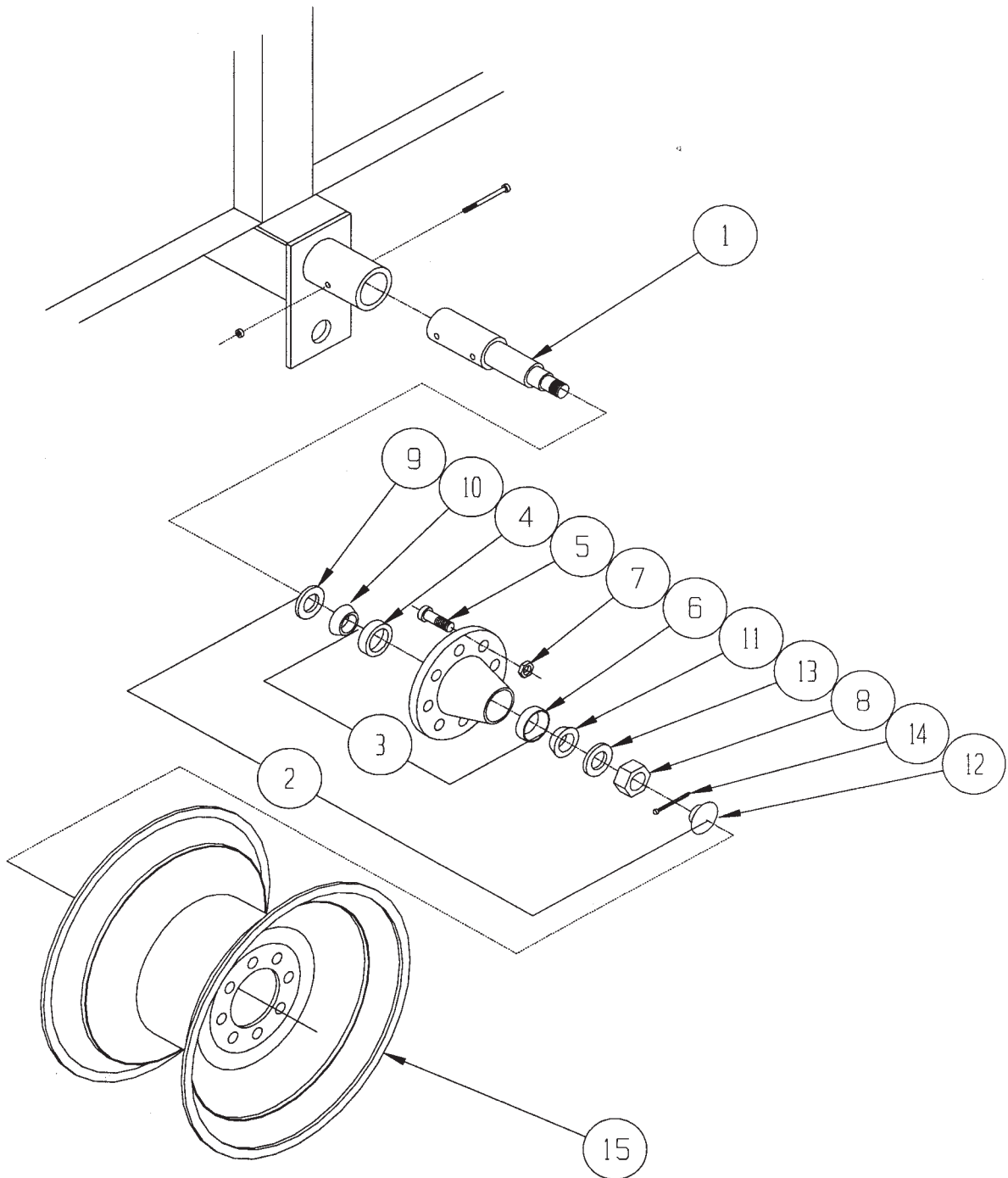

KNIGHT MANUFACTURING CORP. PO BOX 167 BRODHEAD, WI 53520
OFFICE: (608) 897-2131 PARTS/SERVICE: (608) 897-2125 FAX: (608) 897-2561

UNDERCARRIAGE ASSEMBLY SINGLE AXLE (1030 only)

1030/1040-TOW R030399

REF	PART NO	QTY	DESCRIPTION
1	172-270	2	Spindle, 3" x 16"; Mtg Hrd: 3/8" x 4" Bolt & LN
2	171-815	2	Hub, Wheel, 8 Hole Assy
3	171-823	1	Hub, Housing Assy
4	171-824	1	Bearing Cup, Inner; (<i>Timken 382-A</i>)
5	171-826	8	Stud, Wheel; 5/8
6	171-825	1	Bearing Cup, Outer; (<i>Timken LM501310</i>)
7	171-827	8	Wheel Nut; 5/8"
8	171-833	1	Nut, Castle; 1" NF
9	171-831	1	Seal, Lip; (C/R 29968)
10	171-828	1	Inner Bearing Cone; (<i>Timken 387-AS</i>)
11	171-829	1	Outer Bearing Cone; (<i>Timken LM501349</i>)
12	171-830	1	Cap, Hub
13	171-832	1	Washer, Spindle
14	170-056	1	Pin, Cotter; 1/4" x 2"
15	171-809	2	Wheel; 16" x 16.1", 8-Hole, 3/8" Positive Offset
15	172-144	2	Wheel; 20" x 8", 8-Hole, 3/8" Positive Offset
15	172-285	2	Wheel; 22-1/2" x 8-1/4", 8-Hole, 3/8" Positive Offset
15	172-229	2	Wheel; 22-1/2" x 11-1/4", 8-Hole, 3/8" Positive Offset

An asterisk (*) at the end of a part number (XXX-XXX*) indicates that the part is no longer used in production for this application. Superscript letters (XXX-XXX^A) refer to footnotes and/or illustration boxes.

UNDERCARRIAGE ASSEMBLY TANDEM AXLE (1030 only)

1030/1040-TOW R030399

(UNDERCARRIAGE ASSY PARTS are used on unit, Serial Number 1030-213 and after)

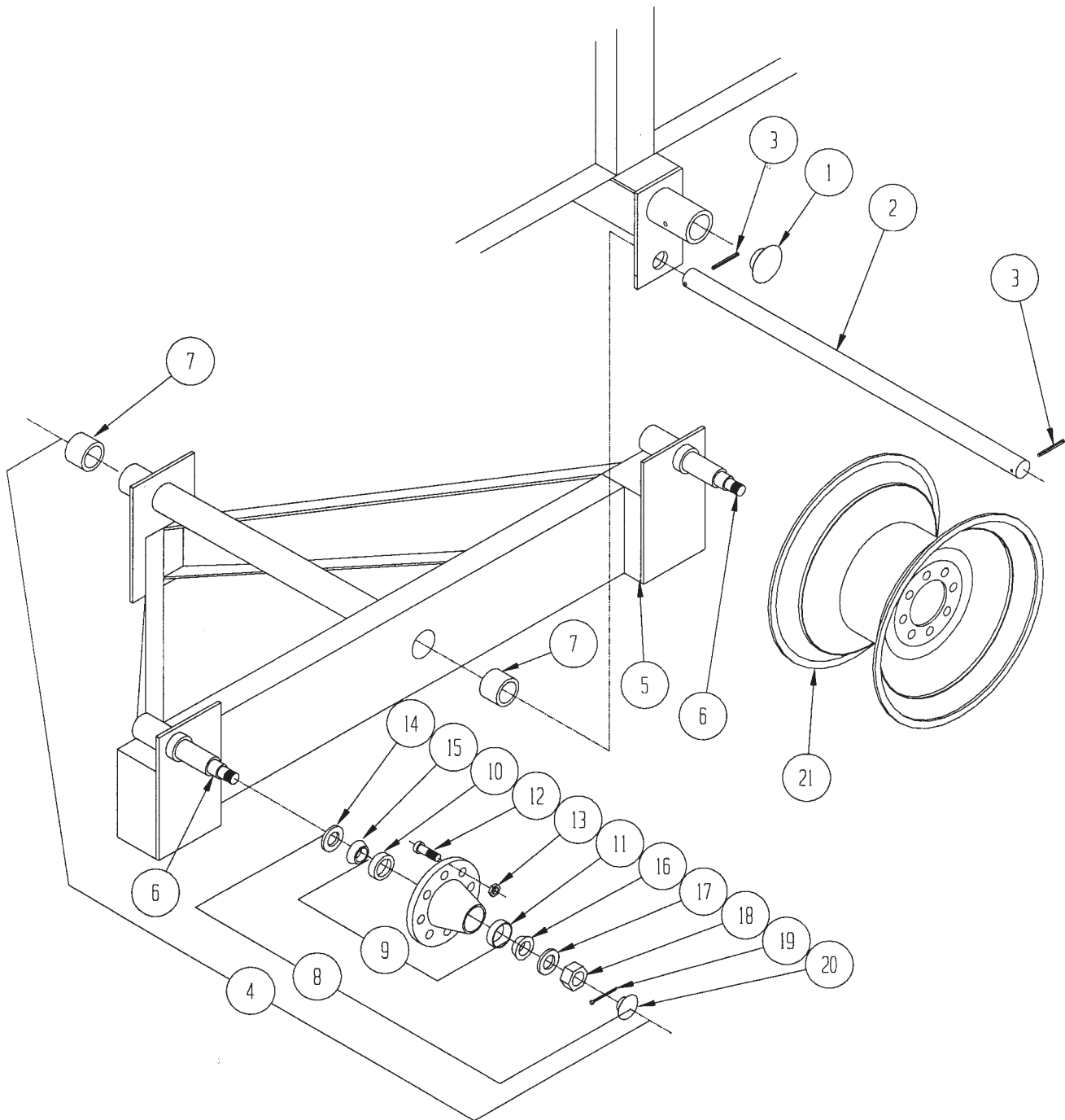

KNIGHT MANUFACTURING CORP. PO BOX 167 BRODHEAD, WI 53520
OFFICE: (608) 897-2131 PARTS/SERVICE: (608) 897-2125 FAX: (608) 897-2561

UNDERCARRIAGE ASSEMBLY TANDEM AXLE (1030 only)
(UNDERCARRIAGE ASSY PARTS are used on unit, Serial Number 1030-213 and after)

REF	PART NO	QTY	DESCRIPTION
1	171-850	2	Cap, Plastic; 3" Dia
2	132-967	2	Bogie Pin; 1 1/4" x 22 5/8"
3	171-414	4	Pin, Roll; 5/16" x 2 1/2"
4	102-565	1	LH Oscillating Axle Assembly
5	102-563	1	LH Oscillating Axle Weldment
6	136-989	2	Spindle, 2 1/2" x 14"
7	170-171	2	Bronze Bushing
4	102-564	1	RH Oscillating Axle Assembly
5	102-562	1	RH Oscillating Axle Weldment
6	136-989	2	Spindle, 2 1/2" x 14"
7	170-171	2	Bronze Bushing
8	174-587	2	Hub, Wheel, 8 Hole Assembly
9	174-582	1	Hub Housing Assy
10	174-583	1	BearingCup, Inner (<i>Timken LM506810</i>)
11	171-825	1	BearingCup, Outer (<i>Timken LM501310</i>)
12	174-586	8	Stud, Wheel, 5/8"
13	171-827	8	Wheel Nut, 5/8"
14	174-585	1	Seal, Lip (<i>C/R 25091</i>)
15	174-584	1	Bearing Cone,Inner (<i>Timken LM506849</i>)
16	171-829	1	Bearing Cone,Outer (<i>Timken LM501349</i>)
17	171-832	1	Washer ,Flat 1"
18	171-833	1	Nut, Castle; 1" NF
19	170-056	1	Cotter Pin; 1/4" x 2"
20	171-830	1	Cap, Dust
21	172-144	4	Wheel; 20" x 8", 8-Hole, 3/8" Pos offset
21	172-285	4	Wheel; 22.5" x 8.25", 8-Hole, 3/8" Pos offset
21	174-580	4	Wheel; 16.1" x 11", 3/8" Pos offset

An asterisk (*) at the end of a part number (XXX-XXX*) indicates that the part is no longer used in production for this application. Superscript letters (XXX-XXX^A) refer to footnotes and/or illustration boxes.

UNDERCARRIAGE ASSEMBLY TANDEM AXLE (1030 only)

1030/1040-TOW R030399

(UNDERCARRIAGE ASSY PARTS are used on unit, Serial Number 1030-212 and before)

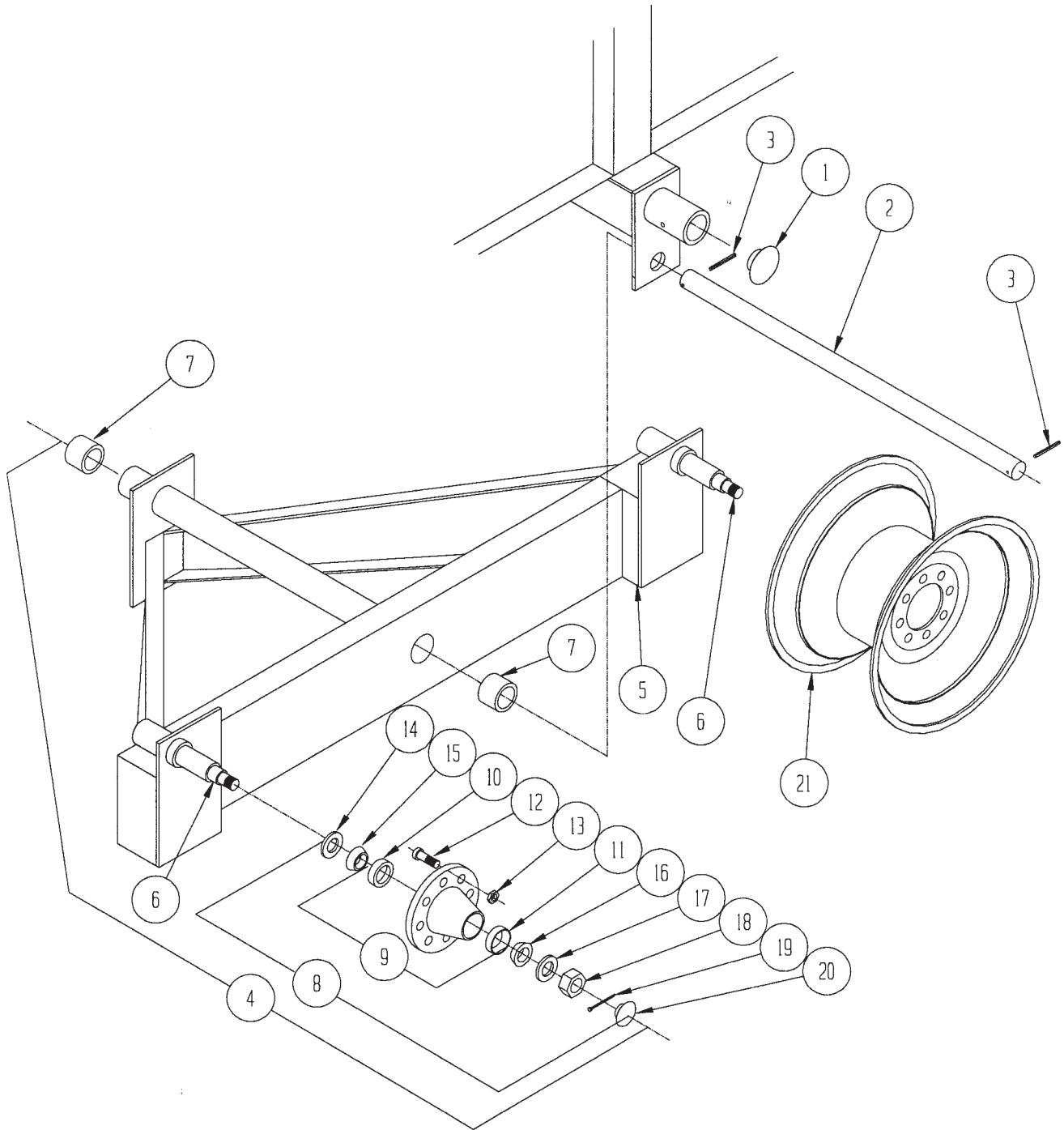

KNIGHT MANUFACTURING CORP. PO BOX 167 BRODHEAD, WI 53520
OFFICE: (608) 897-2131 PARTS/SERVICE: (608) 897-2125 FAX: (608) 897-2561

UNDERCARRIAGE ASSEMBLY TANDEM AXLE (1030 only)**(UNDERCARRIAGE ASSY PARTS are used on unit, Serial Number 1030-212 and before)**

REF	PART NO	QTY	DESCRIPTION
1	171-850	2	Cap, Plastic; 3" Dia
2	132-967	2	Bogie Pin; 1 1/4" x 22 5/8"
3	171-414	4	Pin, Roll; 5/16" x 2 1/2"
4	102-283	1	LH Oscillating Axle Assembly
5	102-233	1	LH Oscillating Axle Weldment
6	134-464	2	Spindle, 2 1/2" x 14 1/8"
7	170-171	2	Bronze Bushing
4	102-282	1	RH Oscillating Axle Assembly
5	102-232	1	RH Oscillating Axle Weldment
6	134-464	2	Spindle, 2 1/2" x 14 1/8"
7	170-171	2	Bronze Bushing
8	170-755	2	Hub, Wheel, 8 Hole Assembly
9	170-705	1	Hub Housing Assy
10	170-553	1	BearingCup, Inner (<i>Timken 3720</i>)
11	170-546	1	BearingCup, Outer (<i>Timken 14276</i>)
12	171-826	8	Stud, Wheel, 5/8"
13	171-827	8	Wheel Nut, 5/8"
14	170-556	1	Seal, Lip (<i>Timken 415082</i>)
15	170-554	1	Bearing Cone,Inner (<i>Timken 3780</i>)
16	170-545	1	Bearing Cone,Outer (<i>Timken 14137A</i>)
17	170-131	1	Washer ,Flat 7/8"
18	170-132	1	Nut, Castle; 7/8" NF
19	170-236	1	Cotter Pin; 5/32" x 1-1/2"
20	170-550	1	Cap, Dust
21	170-112	4	Wheel; 20" x 8", 8-Hole, 1.5 neg offset
21	172-284	4	Wheel; 22.5" x 8.25", 8-Hole, 1.5 neg offset
21	173-119	4	Wheel; 16.1" x 11", 1.5 neg offset

An asterisk (*) at the end of a part number (XXX-XXX*) indicates that the part is no longer used in production for this application. Superscript letters (XXX-XXX^A) refer to footnotes and/or illustration boxes.

UNDERCARRIAGE ASSEMBLY TANDEM AXLE (1040 only)

1030/1040-TOW R030399

(UNDERCARRIAGE ASSY PARTS are used on unit, Serial Number 1040-277 and after)

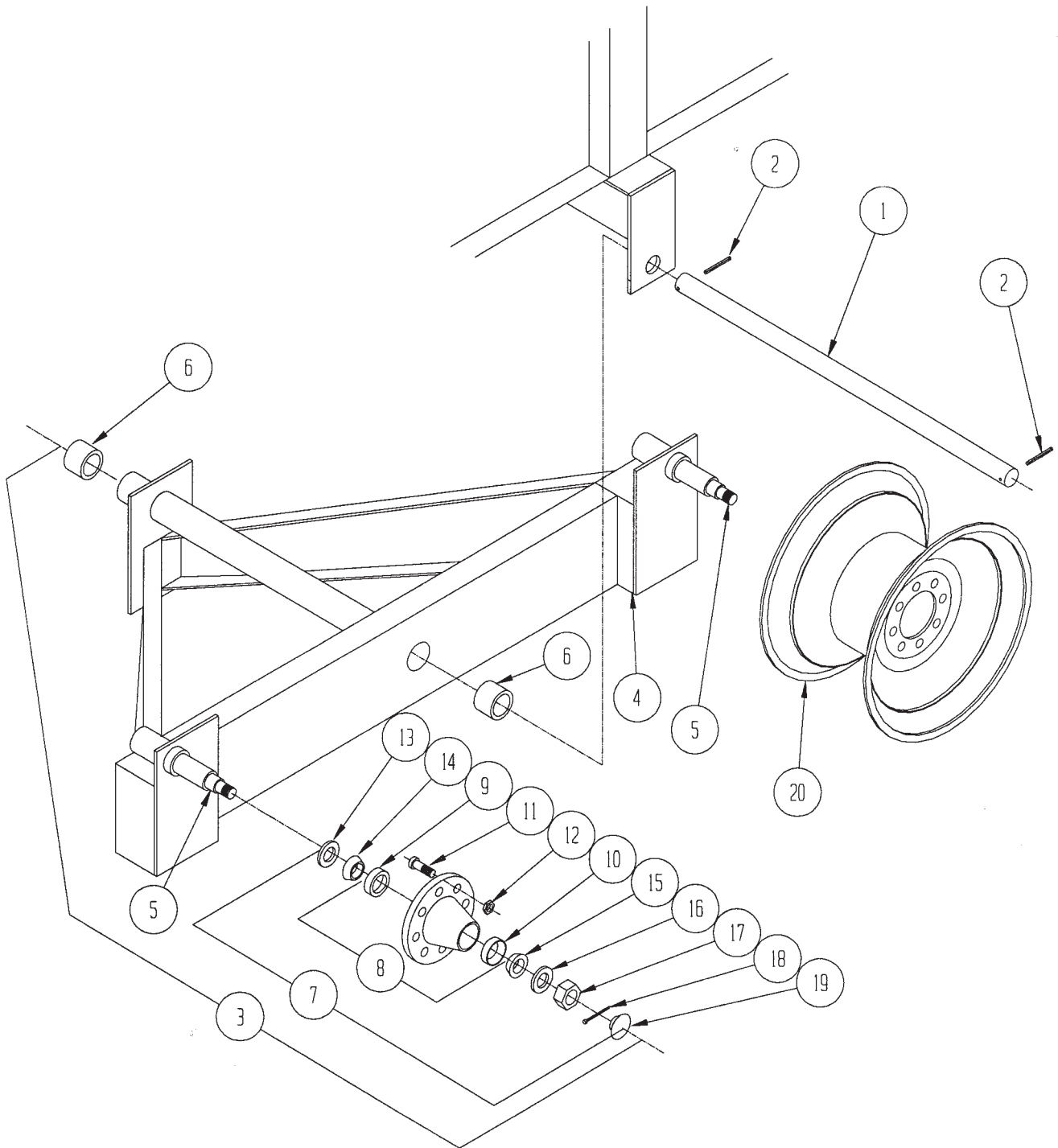

KNIGHT MANUFACTURING CORP. PO BOX 167 BRODHEAD, WI 53520
OFFICE: (608) 897-2131 PARTS/SERVICE: (608) 897-2125 FAX: (608) 897-2561

UNDERCARRIAGE ASSEMBLY TANDEM AXLE (1040 only)
(UNDERCARRIAGE ASSY PARTS are used on unit, Serial Number 1040-277 and after)

REF	PART NO	QTY	DESCRIPTION
1	133-464	2	Bogie Pin; 1 1/4" x 26"
2	171-414	4	Pin, Roll; 5/16" x 2 1/2"
3	102-569	1	LH Oscillating Axle Assembly
4	102-567	1	LH Oscillating Axle Weldment
5	136-989	2	Spindle, 2 1/2" x 14 1/8"
6	170-171	2	Bronze Bushing
3	102-568	1	RH Oscillating Axle Assembly
4	102-566	1	RH Oscillating Axle Weldment
5	136-989	2	Spindle, 2 1/2" x 14 1/8"
6	170-171	2	Bronze Bushing
7	174-587	2	Hub, Wheel, 8 Hole Assembly
8	174-582	1	Hub Housing Assy
9	174-583	1	BearingCup, Inner (<i>Timken LM506810</i>)
10	171-825	1	BearingCup, Outer (<i>Timken LM501310</i>)
11	174-586	8	Stud, Wheel, 5/8"
12	171-827	8	Wheel Nut, 5/8"
13	174-585	1	Seal, Lip (<i>C/R 25091</i>)
14	174-584	1	Bearing Cone,Inner (<i>Timken LM506849</i>)
15	171-829	1	Bearing Cone,Outer (<i>Timken LM501349</i>)
16	171-832	1	Washer ,Flat 1"
17	171-833	1	Nut, Castle; 1" NF
18	170-056	1	Cotter Pin; 1/4" x 2"
19	171-830	1	Cap, Dust
20	172-144	4	Wheel; 20" x 8", 8-Hole, 3/8" Pos offset
20	172-285	4	Wheel; 22.5" x 8.25", 8-Hole, 3/8" Pos offset
20	174-581	4	Wheel; 16.1" x 14", 3/8" Pos offset

An asterisk (*) at the end of a part number (XXX-XXX*) indicates that the part is no longer used in production for this application. Superscript letters (XXX-XXX[^]) refer to footnotes and/or illustration boxes.

UNDERCARRIAGE ASSEMBLY TANDEM AXLE (1040 only)

1030/1040-TOW R030399

(UNDERCARRIAGE ASSY PARTS are used on unit, Serial Number 1040-276 and before)

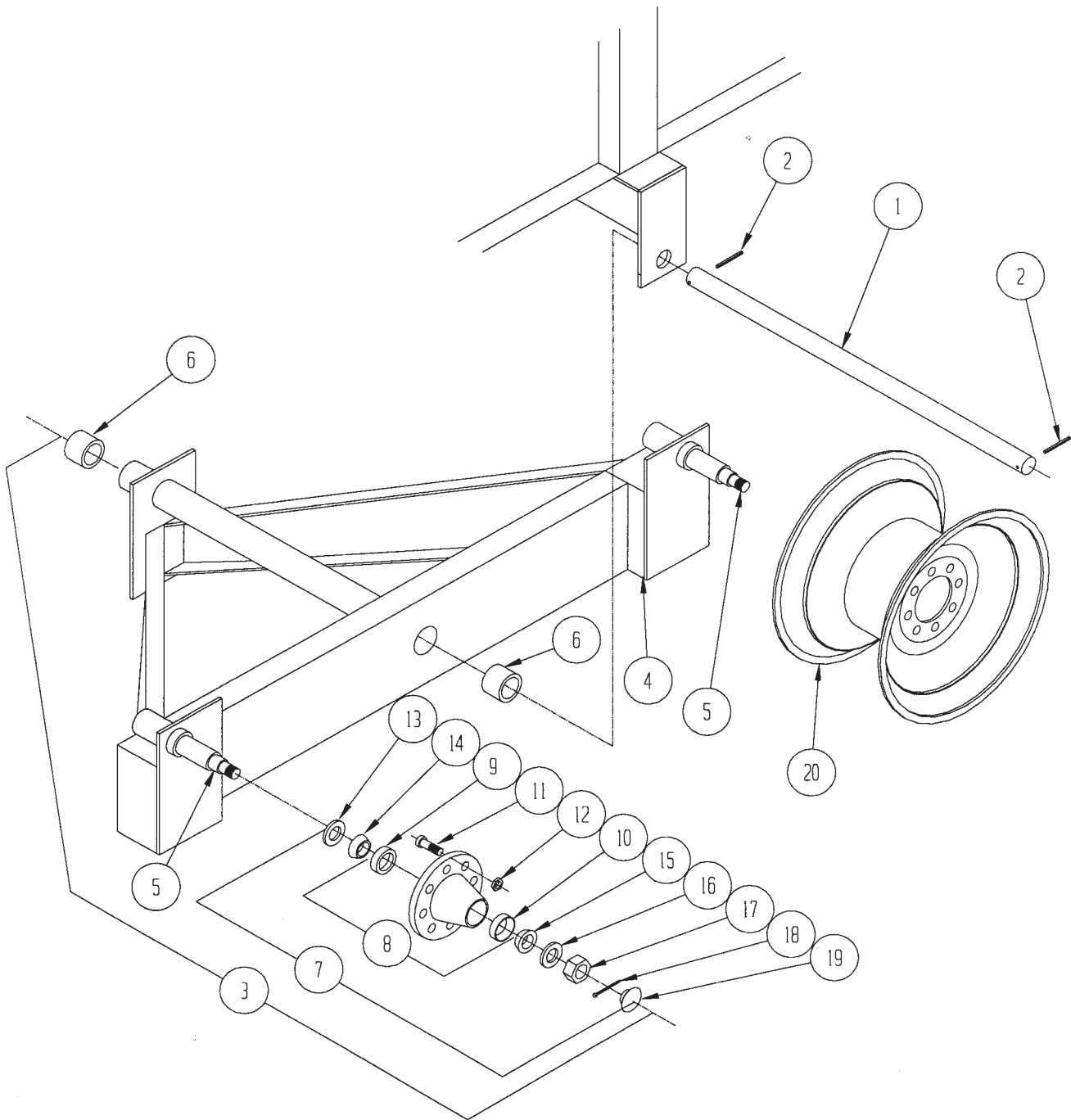

KNIGHT MANUFACTURING CORP. PO BOX 167 BRODHEAD, WI 53520
OFFICE: (608) 897-2131 PARTS/SERVICE: (608) 897-2125 FAX: (608) 897-2561

UNDERCARRIAGE ASSEMBLY TANDEM AXLE (1040 only)
(UNDERCARRIAGE ASSY PARTS are used on unit, Serial Number 1040-276 and before)

REF	PART NO	QTY	DESCRIPTION
1	133-464	2	Bogie Pin; 1 1/4" x 26"
2	171-414	4	Pin, Roll; 5/16" x 2 1/2"
3	101-629	1	LH Oscillating Axle Assembly
4	101-627	1	LH Oscillating Axle Weldment
5	134-464	2	Spindle, 2 1/2" x 14 1/8"
6	170-171	2	Bronze Bushing
3	101-630	1	RH Oscillating Axle Assembly
4	101-628	1	RH Oscillating Axle Weldment
5	134-464	2	Spindle, 2 1/2" x 14 1/8"
6	170-171	2	Bronze Bushing
7	170-755	2	Hub, Wheel, 8 Hole Assembly
8	170-705	1	Hub Housing Assy
9	170-553	1	BearingCup, Inner (Timken#3720)
10	170-546	1	BearingCup, Outer (Timken 14276)
11	171-826	8	Stud, Wheel, 5/8"
12	171-827	8	Wheel Nut, 5/8"
13	170-556	1	Seal, Lip (Timken 415082)
14	170-554	1	Bearing Cone,Inner (Timken 3780)
15	170-545	1	Bearing Cone,Outer (Timken 14137A)
16	170-131	1	Washer ,Flat 7/8"
17	170-132	1	Nut, Castle; 7/8" NF
18	170-236	1	Cotter Pin; 5/32" x 1-1/2"
19	170-550	1	Cap, Dust
20	170-112	4	Wheel; 20" x 8", 8-Hole, 1.5 neg offset
20	172-284	4	Wheel; 22.5" x 8.25", 8-Hole, 1.5 neg offset
20	171-779	4	Wheel; 16.1" x 14", 1.5 neg offset

An asterisk (*) at the end of a part number (XXX-XXX*) indicates that the part is no longer used in production for this application. Superscript letters (XXX-XXX^A) refer to footnotes and/or illustration boxes.

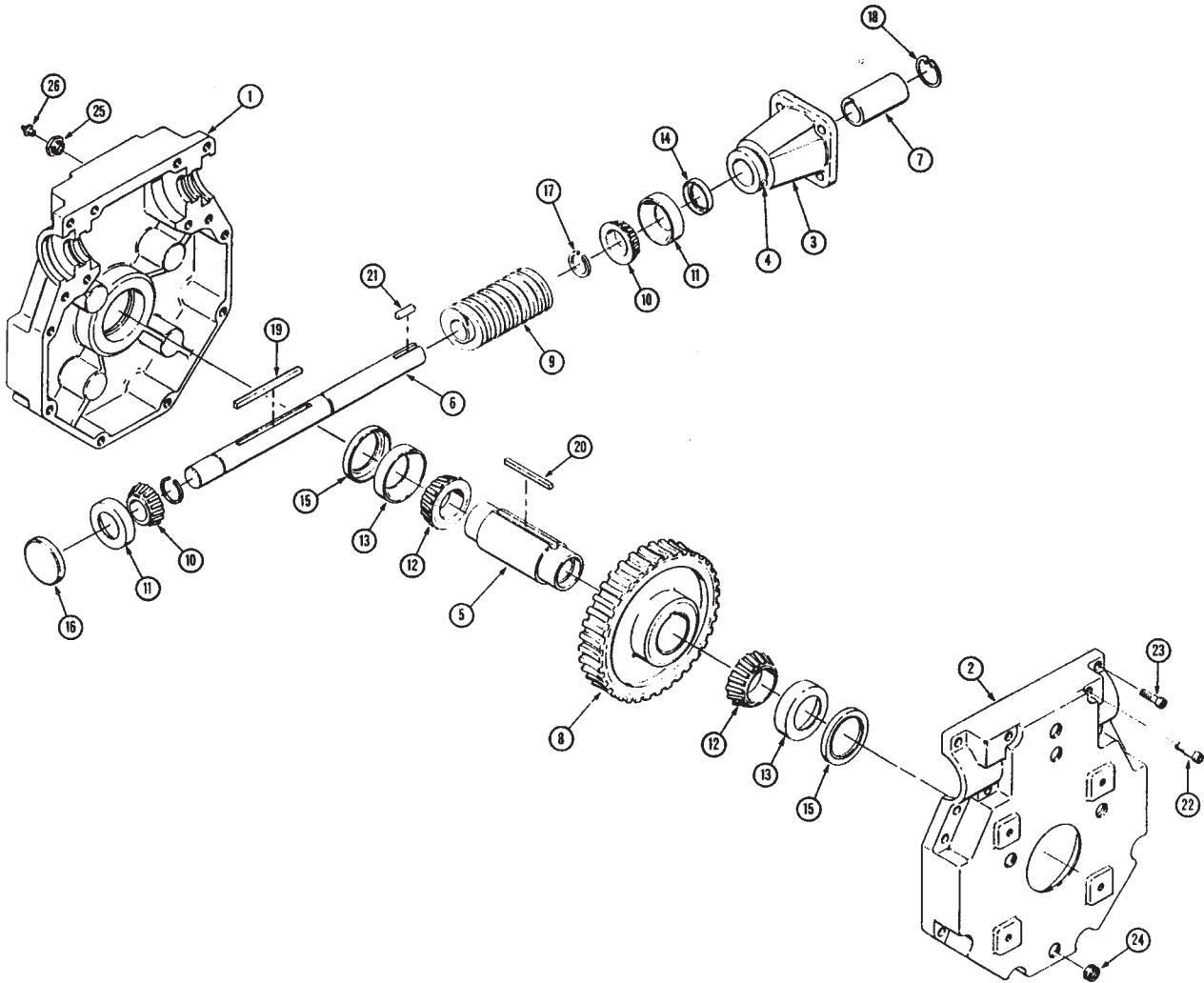

KNIGHT MANUFACTURING CORP. PO BOX 167 BROADHEAD, WI 53520
OFFICE: (608) 897-2131 PARTS/SERVICE: (608) 897-2125 FAX: (608) 897-2561

50:1 GEARCASE PARTS, APRON DRIVE

1030/1040-TOW R030399

REF	PART NO	QTY	DESCRIPTION
	136-626	1	Gearbox Assembly (<i>Superior</i>)
1	173-396	1	Housing
2	173-397	1	Housing
3	173-398	1	Adapter; 4-Bolt
4	173-417	1	Adapter Pin
5	173-399	1	Shaft; (<i>sleeve output</i>)
	172-776	1	Key; 3/8" x 2 3/4"
6	173-400	1	Shaft; (<i>input</i>)
7	173-401	1	Coupler
8	173-402	1	Worm Gear; 50:1 ratio LH
9	173-403	1	Worm; 50:1 LH 1-lead
10	170-534	2	Bearing, Cone (<i>Timken 15101</i>)
11	170-535	2	Bearing Cup (<i>Timken 15245</i>)
12	173-406	2	Bearing Cone (<i>Timken LM104949</i>)
13	173-407	2	Bearing Cup (<i>Timken LM104911</i>)
14	173-408	1	Seal, Lip; 1"
15	173-409	2	Seal, Lip; 2"
16	173-410	1	Dust Cover
17	173-411	1	Ring, Snap; 1"External
18	171-124	1	Ring, Snap; 1"Internal
19	173-413	1	Key; 1/4" x 2 11/16"
20	173-414	1	Key; 3/8" x 1 3/4"
21	173-415	1	Key; 1/4" x 15/16"
22	173-153	4	Bolt; 3/8"-16 x 2 1/4" SHCS
23	173-416	10	Bolt; 3/8"-16 x 1 1/2" SHCS
24	173-152	8	Plug; 1/2" NPT SKHD Hex
25	173-150	1	Bushing; 1/2" NPT to 1/8"NPT
26	170-679	1	Plug, Pipe 1/8" Vented

An asterisk (*) at the end of a part number (XXX-XXX*) indicates that the part is no longer used in production for this application. Superscript letters (XXX-XXX^A) refer to footnotes and/or illustration boxes.

RIGHT ANGLE GEARCASE PARTS, BEATER DRIVE

1030/1040-TOW R030399

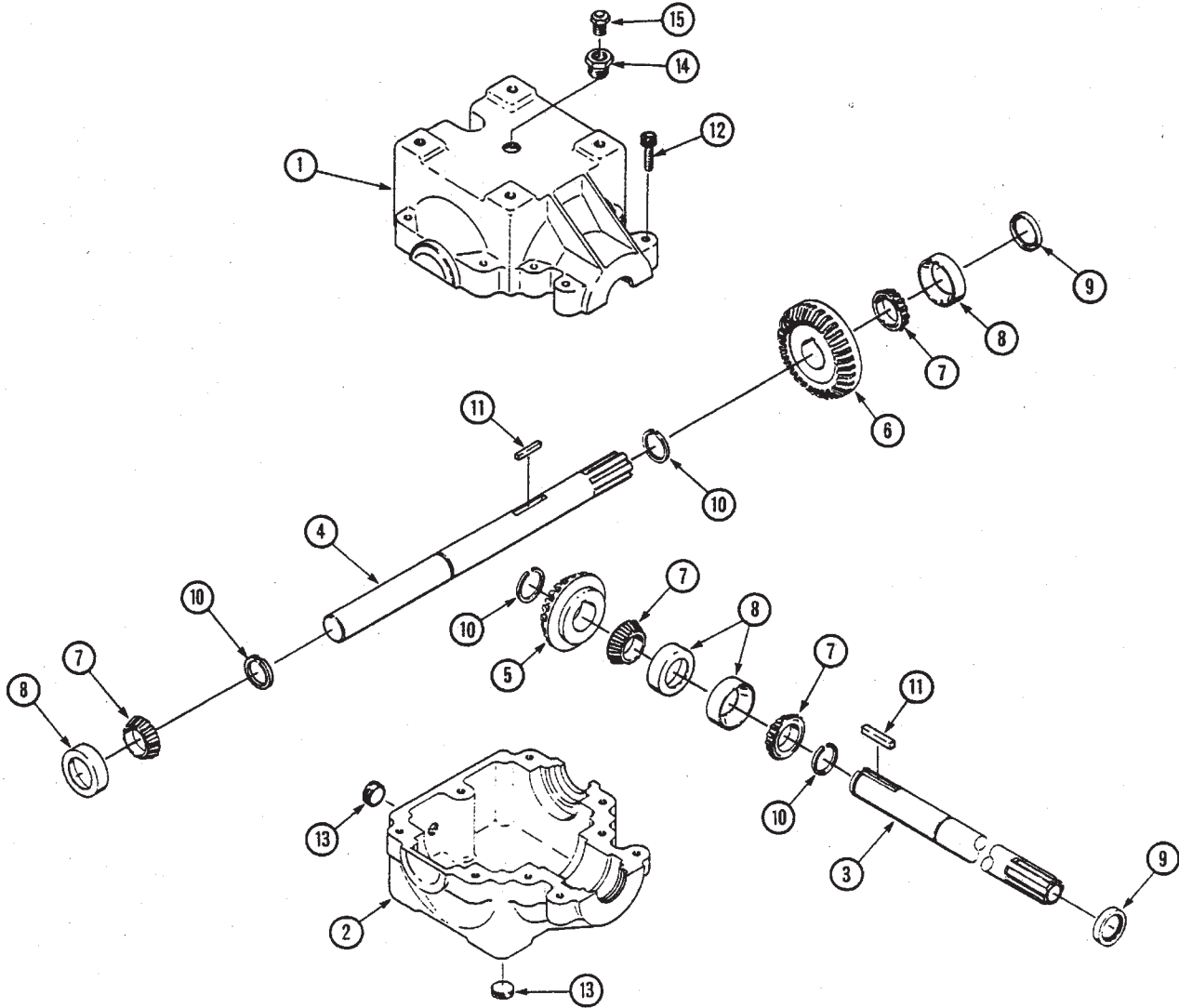

KNIGHT MANUFACTURING CORP. PO BOX 167 BROADHEAD, WI 53520
OFFICE: (608) 897-2131 PARTS/SERVICE: (608) 897-2125 FAX: (608) 897-2561

RIGHT ANGLE GEARCASE PARTS, BEATER DRIVE

1030/1040-TOW R030399

REF	PART NO	QTY	DESCRIPTION
	136-625	1	Gearbox Assembly Complete
1	173-392	1	Housing
2	173-393	1	Housing
3	173-394	1	Shaft; Pinion (<i>input</i>)
4	173-395	1	Shaft; Cross (<i>output</i>)
5	173-127	1	Gear, Bevel Pinion 17 Tooth
6	173-128	1	Gear, Bevel Cross 23 Tooth
7	170-545	4	Bearing, Cone (<i>Timken 14137A</i>)
8	170-546	4	Bearing Cup (<i>Timken 14276</i>)
9	173-141	2	Seal, Lip; 1-3/8"
10	173-144	4	Ring, Snap; 1-3/8" External
11	173-147	2	Key; 5/16" sq x 1.2" lg
12	173-153	9	Bolt; 3/8"-16 x 2.1/4" SHCS
13	173-152	2	Plug; 1/2" NPT SKHD HEX
14	173-150	1	Bushing; 1/2" NPT to 1/8" NPT
15	170-679	1	Plug, Pipe; 1/8" Vented

An asterisk (*) at the end of a part number (XXX-XXX*) indicates that the part is no longer used in production for this application. Superscript letters (XXX-XXX^A) refer to footnotes and/or illustration boxes.

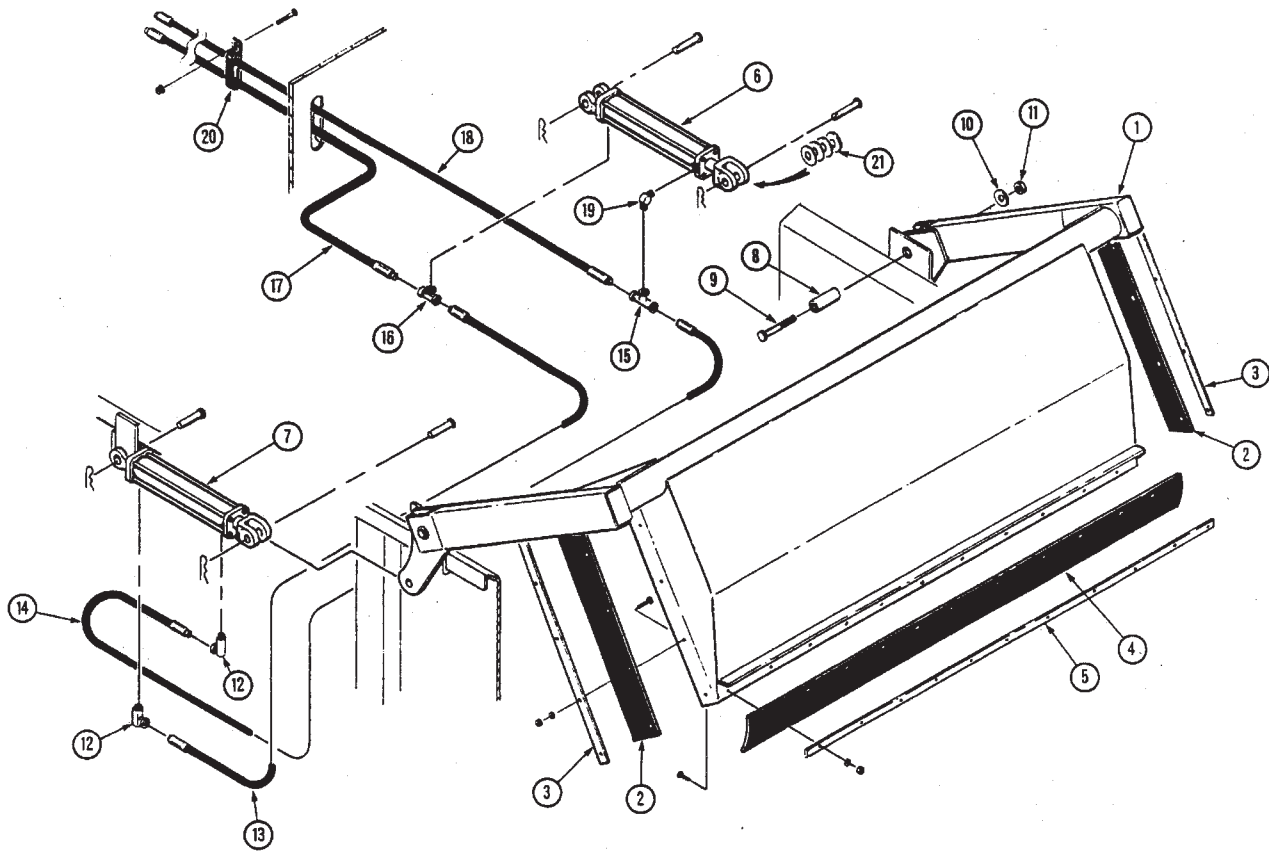

KNIGHT MANUFACTURING CORP. PO BOX 167 BROADHEAD, WI 53520
OFFICE: (608) 897-2131 PARTS/SERVICE: (608) 897-2125 FAX: (608) 897-2561

HYDRAULIC END GATE

1030/1040-TOW R030399

REF	PART NO	QTY	DESCRIPTION
1	103-508	1	Hydraulic End Gate Weldment (1030 only)
	103-509	1	Hydraulic End Gate Weldment (1040 only)
2	136-690	2	Rubber Side Belt; Mtg Hrd: 1/4" x 7/8" Bolt, Nut (3 EA) (1030 only)
	136-688	2	Rubber Side Belt; Mtg Hrd: 1/4" x 7/8" Bolt, Nut (4 EA) (1040 only)
3	136-982	2	Side Belt Retainer (1030 only)
	136-687	2	Side Belt Retainer (1040 only)
4	136-685	1	Rubber Lower Belt; Mtg Hrd: 1/4" x 7/8" Bolt, Nut (11 EA)
5	136-686	1	Lower Belt Retainer
6	173-272	1	Cylinder, 2" x 10" Tie Rod (Seal Kit 170075)
	173-274	2	Pin, Clevis 1" dia.
	173-275	2	Pin, Hair
	173-276	2	Rod, Clevis
	173-376	2	Cap, Rod
	173-374	2	Clevis, Base
7	173-273	1	Cylinder, 2" x 10" Tie Rod (Seal Kit 170075)
	173-274	2	Pin, Clevis 1" dia.
	173-275	2	Pin, Hair
	173-276	2	Rod, Clevis
	173-376	2	Cap, Rod
	173-374	2	Clevis, Base
8	136-619	2	Pivot Bushing
9	173-299	2	Pivot Bolt; 7/8-9 x 4" (grade 5)
10	173-293	2	Washer, Flat; 7/8"
11	173-069	2	Nut, Hex Lock; 7/8"
12	171-030	2	Adapter, 90° Swivel; 3/8" NPT
13	173-269	1	Hydraulic Hose; 1/4" x 120" (1030 only)
	170-465	1	Hydraulic Hose; 1/4" x 127" (1040 only)
14	172-042	1	Hydraulic Hose; 1/4" x 111" (1030 only)
	170-465	1	Hydraulic Hose; 1/4" x 127" (1040 only)
15	173-268	1	Swivel Tee Fitting; 3/8" NPTM FM
16	172-807	1	Adapter Tee Fitting; 3/8" male to female
17	171-471	1	Hydraulic Hose; 1/4" x 226"
18	173-285	1	Hydraulic Hose; 1/4" x 234"
19	173-267	1	Adapter 90°; 3/8" NPTF M
20	171-782	1	Clamp, Tube; 9/16" Double; Mtg Hrd: 5/16" x 1" Bolt. Fln
21	170-122	4	Flat Washer Spacer; 1" SAE Flat (1030 only)

An asterisk (*) at the end of a part number (XXX-XXX*) indicates that the part is no longer used in production for this application. Superscript letters (XXX-XXX^A) refer to footnotes and/or illustration boxes.

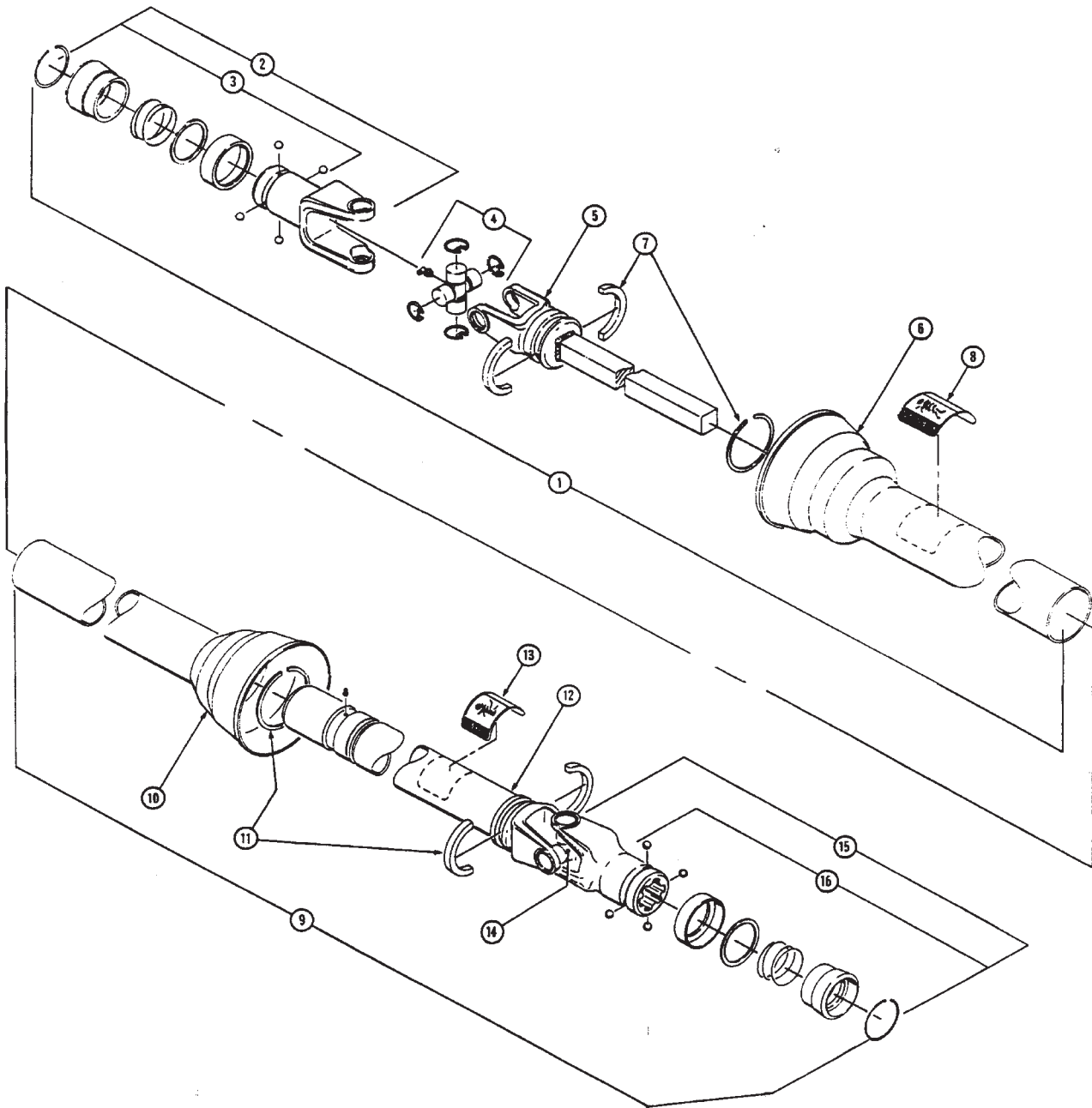

KNIGHT MANUFACTURING CORP. PO BOX 167 BRODHEAD, WI 53520
OFFICE: (608) 897-2131 PARTS/SERVICE: (608) 897-2125 FAX: (608) 897-2561

REF	PART NO	QTY	DESCRIPTION
	171-530		Weasler 14R Driveline with Guard (1-3/8" 6 spline)
1	171-531	1	Joint and Shaft Half with Guard
2	172-018	1	Spring Slide Lock Yoke
3	172-019	1	Spring Slide Lock Repair Kit
4	170-720	1	Cross and Bearing Kit
5	171-001	1	Yoke and Shaft Assy.
6	171-532	1	Outer Guard
7	170-220	1	Nylon Repair Kit
8	171-799	1	Safety Decal
9	171-533	1	Joint and Tube Half with Guard
10	171-534	1	Inner Guard
11	170-220	1	Nylon Repair Kit
12	171-002	1	Yoke Tube and Slip Sleeve Assy.
13	171-550	1	Safety Decal
14	170-720	1	Cross and Bearing Kit
15	172-018	1	Spring Lock Yoke Assy.
16	172-019	1	Spring Slide Lock Repair Kit

An asterisk (*) at the end of a part number (XXX-XXX*) indicates that the part is no longer used in production for this application. Superscript letters (XXX-XXX^A) refer to footnotes and/or illustration boxes.

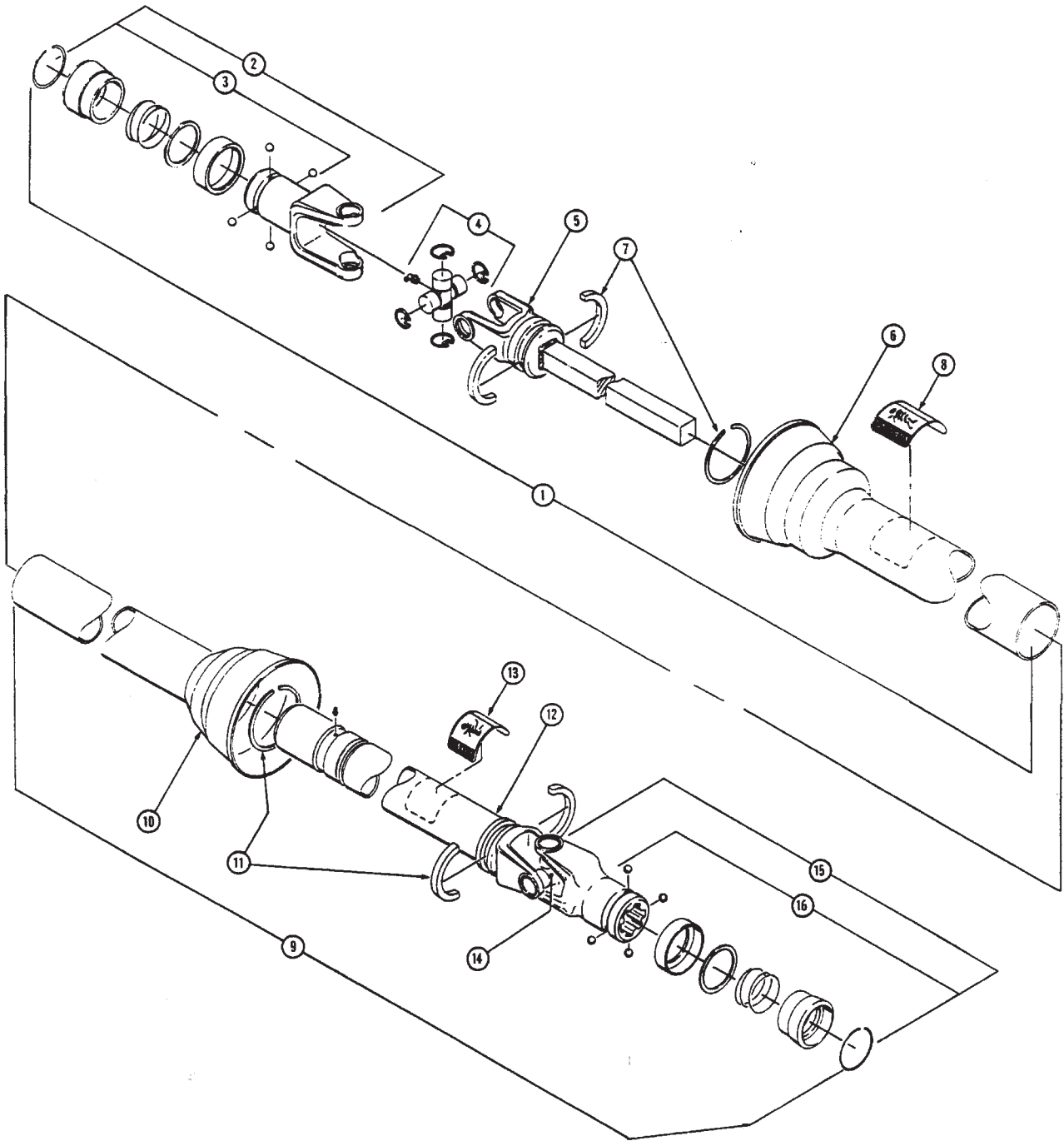

KNIGHT MANUFACTURING CORP. PO BOX 167 BRODHEAD, WI 53520
OFFICE: (608) 897-2131 PARTS/SERVICE: (608) 897-2125 FAX: (608) 897-2561

REF	PART NO	QTY	DESCRIPTION
	173-254		Weasler 14R Driveline with Guard (1-3/8" 21 spline)
1	173-255	1	Joint and Shaft Half with Guard
2	172-022	1	Spring Slide Lock Yoke
3	172-019	1	Spring Slide Lock Repair Kit (one kit per PTO half)
4	170-720	1	Cross and Bearing Kit
5	171-001	1	Yoke and Shaft Assy.
6	171-532	1	Outer Guard
7	170-220	1	Nylon Repair Kit
8	171-799	1	Safety Decal
9	171-533	1	Joint and Tube Half with Guard
10	171-534	1	Inner Guard
11	170-220	1	Nylon Repair Kit
12	171-002	1	Yoke Tube and Slip Sleeve Assy.
13	171-550	1	Safety Decal
14	170-720	1	Cross and Bearing Kit
15	172-018	1	Spring Lock Yoke Assy.
16	172-019	1	Spring Slide Lock Repair Kit

An asterisk (*) at the end of a part number (XXX-XXX*) indicates that the part is no longer used in production for this application. Superscript letters (XXX-XXX^A) refer to footnotes and/or illustration boxes.

JACKSTAND

1030/1040-TOW R030399

REF	PART NO	QTY	DESCRIPTION
	170-984	1	Jackstand Assy
1	170-386	1	Crank Assy
2	171-860	1	Crank Pin (Includes "C" Washer)
3	170-987	1	Pin And Chain Assy
4	170-397	1	Thrust Bearing Kit
5	171-941	1	Inner Tube Assembly (Includes Nut & Screw)
6	170-985	1	Mount Tube

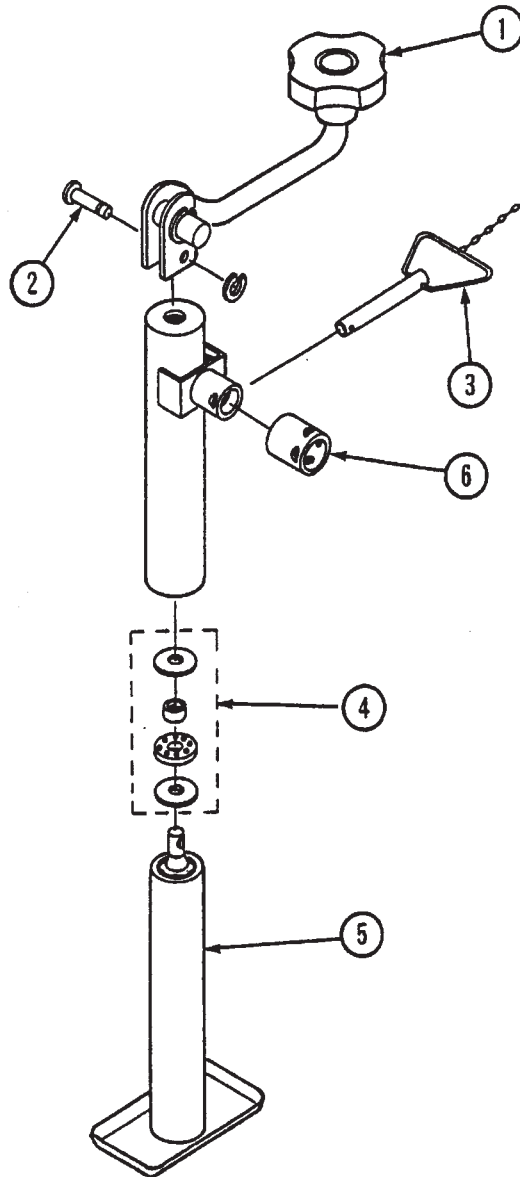

KNIGHT MANUFACTURING CORP. PO BOX 167 BROADHEAD, WI 53520
OFFICE: (608) 897-2131 PARTS/SERVICE: (608) 897-2125 FAX: (608) 897-2561

DECALS AND PAINT

1030/1040-TOW R030399

Decals

PART NO	QTY	DESCRIPTION
173-348	1	Complete Decal Set (1030-tow)
173-350	1	Complete Decal Set (1040-tow)
170-490	1	Important Reduce Engine Speed Before Engaging PTO
170-868	2	Apron Tension
171-602	2	Red Reflector 2" x 6 ³ / ₈ "
171-712	1	Retighten Set Screws
171-913	1	Danger - Do Not Operate Unless Shields Are In Place
171-915	1	Danger - Shield Missing
172-171	1	Caution - Read Operators Manual
172-602	2	Danger - Rotating Driveline
172-868	3	"KNIGHT"
172-889	2	Danger - Beater Entanglement
172-890	2	Danger - Crushing Under Endgate
173-040	1	Caution - Operate At Correct PTO Speed
173-078	4	Danger - Shield Missing
173-223	2	"1030" (1030 only)
173-224	2	"1040" (1040 only)
173-259	2	Logo - Knight Head in Shield
173-351	1	Caution - Do Not Use As On / Off Control
173-352	1	Fast / Slow

Paint

170-366	Yellow Paint; 12 oz. Aerosol
170-367	Red Paint; 12 oz. Aerosol
170-812	Yellow Paint; Quart
170-813	Yellow Paint; Gallon
170-814	Red Paint; Quart
170-815	Red Paint; Gallon

An asterisk (*) at the end of a part number (XXX-XXX*) indicates that the part is no longer used in production for this application. Superscript letters (XXX-XXX[^]) refer to footnotes and/or illustration boxes.

DISASSEMBLY PROCEDURE:

1. Remove the four snap rings as shown in Figure #1.
2. Position the joint in an open vise, with each ear of one yoke supported by a vise jaw. Figure #2
3. With a soft hammer or mallet, strike the top ear of the unsupported yoke as indicated by the arrow in Figure #2. This will drive the top bushing outward approximately 3/8 of an inch.
4. Grip the loosened bushing in the vise as shown in Fig. #3. Drive the yoke off the bushing by striking the yoke ear with a mallet in the direction of the arrow. (Fig. #3)
5. This same procedure should be followed to remove the bushing that is directly opposite the one in Step 4. After this, the yoke itself may be removed.
6. To remove the remaining two bushings, support the cross as shown in Figure #4. Make certain that the vise jaws are covered with brass protectors. By striking the yoke ear as indicated by the arrow in Figure #4, the remaining bushings can be removed by repeating the procedure called for in Step 4 & Figure #3.

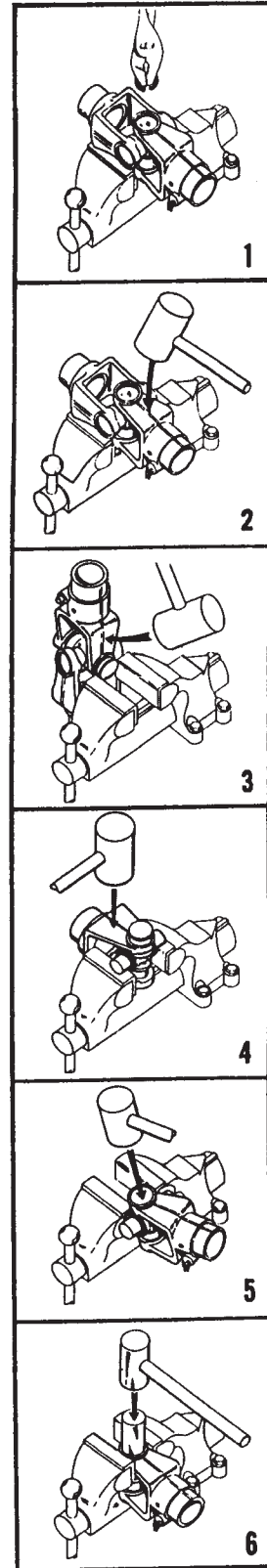

ASSEMBLY PROCEDURE:

DURING REASSEMBLY, BE SURE THAT THERE IS NO DIRT ON THE TRUNNIONS OF THE CROSS OR IN THE BUSHINGS!

1. Start one bushing in the yoke ear and position the center cross through the yoke. Drive the first bushing down flush with the outside surface of the ear as shown in Fig. #5. Support the underside of the ear so as not to spring the yoke.
2. Clamp the ear in the vise as shown in Figure #6. Use a punch of the same diameter as the bushing, drive the bushing past the snap ring groove, and insert a snap ring.
3. Position the cross and drive in the opposite bushing as described in Steps 1 & 2, and Insert a snap ring.
4. Assemble the second yoke in the same manner.
5. To insure proper seating, and to eliminate any possible tightness, strike the forged surfaces of the yoke ears with a mallet. This will insure a free flexing joint.
6. Lubricate with a good grade of multipurpose grease.

HARDWARE PART NUMBER LISTING

All hex head bolts up to and including 1/2" dia are grade 5 unless otherwise specified. All fasteners are NC thread unless otherwise specified.

HEX NUTS AND WASHERS

SIZE	Hex Nuts	Lock Nuts	Jam Nuts	Flat Washer	Lock Washer
#6-32	172-418	174-188			172-417
#10-32	171-606	174-073		171-525	171-605
1/4"	170-125	170-069	171-386	170-301	170-124
5/16"	170-119	170-137	173-521	170-127	170-118
3/8"	170-007	170-047	170-022	170-244	170-006
7/16"	170-062	170-239	170-046	170-138	170-061
1/2"	170-004	170-042	170-036	170-040	170-003
5/8"	170-011	170-031	170-037	170-066	170-010
3/4"	170-017	170-185	170-035	170-015	170-016
7/8"	171-776	171-093		173-298	172-003
1"	173-022	174-928	174-927	170-122	171-021
1-1/4"	170-130 NF/175-006 NC			170928	175-005

HEX HEAD BOLTS

Bolt Size	Part No		
1/4 x 3/4	170-803	3/8 x 4-1/2	170-519
1/4 x 7/8	171-094	3/8 x 5	170-493
1/4 x 1	170-310	3/8 x 5-1/2	174-196
1/4 x 1-1/2	170-068	3/8 x 5-1/2 (Full thread)	170-593
1/4 x 2	172-986	3/8 x 6	174-304
1/4 x 2 (Grade 8)	175-073	3/8 x 6-1/2	171-291
1/4 x 2-3/4	171-203	7/16 x 1	170-032
1/4 x 3	171-403	7/16 x 1-1/4	170-354
1/4 x 3-1/2	173-640	7/16 x 1-1/4 (Grade 8)	174-216
1/4 x 4	173-505	1/2 x 3/4	171-252
5/16 x 3/4	170-262	1/2 x 1	170-149
5/16 x 3/4 (Stainless steel)	174-787	1/2 x 1-1/4	170-373
5/16 x 1	170-027	1/2 x 1-1/2	170-002
5/16 x 1-1/4	170-188	1/2 x 1-3/4	171-774
5/16 x 1-1/2	170-372	1/2 x 2	171-802
5/16 x 1-3/4	170-263	1/2 x 2-1/4	172-387
5/16 x 2	172-987	1/2 x 2-1/2 (Full thread)	171-099
5/16 x 2-1/2	170-369	1/2 x 2-1/2	170-885
5/16 x 3	170-295	1/2 x 2-3/4	172-007
3/8 x 3/4	170-439	1/2 x 3	170-168
3/8 x 3/4 (Stainless steel)	174-788	1/2 x 3-1/2	170-167
3/8 x 7/8	170-268	1/2 x 3-1/2 (Grade 8)	172-950
3/8 x 7/8 (soc. hd.capscrew)	172-044	1/2 x 4	173-111
3/8 x 1	170-054	1/2 x 4 (Full thread)	171-509
3/8 x 1-1/4	170-005	1/2 x 4-1/2 (Grade 8)	171-573
3/8 x 1-1/4 (Stainless steel)	174-917	1/2 x 5	171-412
3/8 x 1-1/2	170-368	1/2 x 6	173-506
3/8 x 2	170-245	1/2 x 6 (Grade 8)	174-944
3/8 x 2-1/4	170-320	1/2 x 6-1/2	173-711
3/8 x 2-1/2	170-257	1/2 x 7-1/2	175-107
3/8 x 2-1/2 (Full thread)	170-128	1/2 x 8-1/2	170-504
3/8 x 3	170-380	1/2 x 11	170-506
3/8 x 3-1/2	170-292	5/8 x 1	171-087
3/8 x 4	170-877	5/8 x 1-1/4	171-366
		5/8 x 1-1/2	170-153
		5/8 x 1-3/4 (Full thread)	170-030
		5/8 x 2	170-009
		5/8 x 2 (Full thread)	171-772
		5/8 x 2-1/4	173-009
		5/8 x 2-1/2 (Full thread)	170-129
		5/8 x 2-1/2	172-381
		5/8 x 2-3/4	172-356
		5/8 x 3	170-258
		5/8 x 3-1/2	170-038
		5/8 x 4-1/2	170-067
		5/8 x 5	170-065
		5/8 x 5-1/2	172-421
		5/8 x 7-1/2	173-019
		5/8 x 9-1/2	171-039
		3/4 x 2 (Full thread)	170-058
		3/4 x 2	171-768
		3/4 x 2 (Grade 8)	171-877
		3/4 x 2-1/4	171-275
		3/4 x 2-1/2	170-374
		3/4 x 2-1/2 (Grade 8)	175-055
		3/4 x 3	170-014
		3/4 x 3-1/2	170-195
		3/4 x 3-1/2 (Grade 8)	171-899
		3/4 x 4-1/2	170-846
		3/4 x 6	171-116
		3/4 x 8	173-509
		7/8 x 2-1/4	172-892
		7/8 x 3	172-002
		7/8 x 3-1/2	173-020
		7/8 x 4	173-299
		7/8 x 4 UNF	171-092
		7/8 x 8 (grade8) UNF	173-715
		1 x 3-1/2	173-021
		1 x 8 (grade 8) UNF	173-713
		1-1/4 x 4-1/2 (grade 8)	175-003

HARDWARE PART NUMBER LISTING CONTINUED:

TRUSS HEAD BOLTS

#6-32 x 3/4	172-416
#6-32 x 1	173-079
#8-32 x 1-1/2	171-210
#10-32 x 3/4	171-604
#10-32 x 1	172-882
1/4 x 3/4	170-193
1/4 x 1	170-194
5/16 x 1	170-117

CARRIAGE BOLTS

1/4 x 2-1/2	171-394
1/4 x 3	170-509
5/16 x 2-1/2	171-395
3/8 x 3-1/2	171-283
3/8 x 4-1/2	170-191
3/8 x 5	170-495
3/8 x 6-1/2	171-174
1/2 x 1-1/2	174-045
1/2 x 1-1/2 (Grade 5)	174-918
1/2 x 6-1/2	171-098
1/2 x 9	171-255
5/8 x 2	175-110
5/8 x 2-1/2	174-790

PLOW BOLTS

5/8 x 2	174-767
---------------	---------

ZERKS

1/8 NPT	170-865
1/8 NPT-45 Deg	170-864
1/8 NPT-65 Deg	170-215
1/8 NPT-90 Deg	170-866
3/16 drive in	174-124
1/4-28	170-023
1/4-28 - 45 Deg	170-148
1/4-28 - 90 Deg	170-049
1/4 NPT	170-277
1/4 NPT - 45 Deg	174-130

ROLLER CHAIN

CONNECTOR LINKS

#50	170-088
#50-2R	170-094
#60	170-089
#60-2R	170-095
#60H	171-102
#80	170-090
#80H	170-821
#100	170-091
#100H	171-969
#120	170-092

#140	170-093
#140H	173-552
#160	170-888

OFFSET LINKS

#50	170-096
#50-2R	170-102
#60	170-097
#60-2R	170-103
#60H	171-103
#80	170-098
#80H	170-820
#100	170-099
#100H	172-145
#120	170-100
#140	170-101
#140H	173-553
#160	170-887

ROLLER LINKS

#50	171-415
#60	171-416
#80	171-417
#80H	170-795
#100	171-418
#100H	172-146
#120	171-419
#140	171-420
#160	171-421

COTTER PINS

1/16 x 1/2	170-992
3/32 x 3/4	170-364
1/8 x 1	170-045
1/8 x 1-1/2	170-382
5/32 x 1-1/2	170-236
5/32 x 3	170-135
3/16 x 1-1/4	170-991
3/16 x 2	170-115
1/4 x 1-1/2	170-521
1/4 x 2	170-056

SET SCREWS

5/16 x 5/16	170-248
5/16 x 1/2	170-254
3/8 x 1/4	170-856
3/8 x 3/8	170-151
1/2 x 5/8	170-249
1/2 x 1-1/4 (half dog point)	171-085

PART NUMBER INDEX

1030/1040-TOW

101-446	5	136-656	7	170-813	31
101-449	5	136-657	7	170-814	31
101-627	19	136-661	5	170-859	3
101-628	19	136-665	5	170-865	3
101-629	19	136-666	5	170-868	31
101-630	19	136-673	7	170-893	7
102-232	15	136-674	7	170-984	30
102-233	15	136-676	5	170-985	30
102-282	15	136-678	7	170-987	30
102-283	15	136-681	7	171-001	27,29
102-374	3	136-682	5	171-002	27,29
102-447	5	136-685	25	171-030	25
102-448	3	136-686	25	171-124	21
102-449	3	136-687	25	171-409	5
102-450	3	136-688	25	171-414	13,15,17,19
102-453	5	136-690	25	171-471	25
102-454	5	136-695	7	171-530	27
102-455	5	136-699	3	171-531	27
102-460	7	136-706	7	171-532	27,29
102-461	5	136-982	25	171-533	27,29
102-462	7	136-989	13,17	171-534	27,29
102-463	7	170-000	5,7	171-550	27,29
102-466	7	170-023	5	171-561	3
102-467	7	170-028	5	171-602	31
102-520	3	170-040	3	171-712	31
102-562	13	170-042	3	171-779	19
102-563	13	170-056	11,13,17	171-782	25
102-564	13	170-086	5	171-799	27,29
102-565	13	170-110	5	171-809	11
102-566	17	170-112	15,19	171-815	11
102-567	17	170-122	25	171-823	11
102-568	17	170-124	3	171-824	11
102-569	17	170-125	3	171-825	11,13,17
103-508	25	170-131	15,19	171-826	11,15
103-509	25	170-132	15,19	171-827	11,13,15,17,19
130-484	3	170-142	5	171-828	11
132-128	5	170-171	17	171-829	11,13,17
132-967	13	170-171	13	171-830	11,13,17
133-464	17,19	170-171	5,13,15,17,19	171-831	11
133-552	5	170-220	27,29	171-832	11,13,17
134-155	7	170-236	15,19	171-833	11,13,17
134-464	15,19	170-263	5	171-850	13,15
134-670	5	170-318	3	171-860	30
136-546	3	170-345	7	171-913	31
136-561	5	170-366	31	171-915	31
136-574	5	170-367	31	171-941	30
136-575	5	170-386	30	172-018	27,29
136-582	3	170-397	30	172-019	27,29
136-592	5	170-410	7	172-022	29
136-607	7	170-448	3	172-042	25
136-611	5	170-465	25	172-144	11,13,17
136-615	5	170-490	31	172-171	31
136-619	25	170-499	5,7	172-229	11
136-622	3	170-500	3	172-270	11
136-623	7	170-504	3	172-284	15,19
136-624	7	170-534	21	172-285	11,13,17
136-625	5,23	170-535	21	172-602	31
136-626	3,21	170-545	19,23	172-776	21
136-628	7	170-546	15,19,23	172-807	25
136-629	7	170-550	15,19	172-828	5
136-630	5	170-553	15,19	172-868	31
136-631	7	170-554	15,19	172-889	31
136-632	7	170-556	15,19	172-890	31
136-635	7	170-627	5	172-986	3
136-636	7	170-679	21,23	173-040	31
136-642	5	170-705	15,19	173-069	25
136-643	5	170-720	27,29	173-078	7,31
136-645	5	170-755	15,19	173-119	15
136-646	5	170-812	31	173-127	23

An asterisk (*) at the end of a part number (XXX-XXX*) indicates that the part is no longer used in production for this application. Superscript letters (XXX-XXX^A) refer to footnotes and/or illustration boxes.

PART NUMBER INDEX

1030/1040-TOW

173-128	23	173-414	21
173-141	23	173-415	21
173-144	23	173-416	21
173-147	23	173-417	21
173-150	21,23	174-580	13
173-152	21,23	174-581	17
173-153	21,23	174-582	13
173-223	31	174-583	13,17
173-224	31	174-584	13,17
173-254	29	174-585	17,17
173-255	29	174-586	13,17
173-256	5	174-587	13,17
173-257	5		
173-258	5		
173-259	31		
173-260	3		
173-261	3		
173-262	3		
173-264	5		
173-266	5		
173-267	25		
173-268	25		
173-269	25		
173-272	25		
173-273	25		
173-274	25		
173-275	25		
173-276	25		
173-285	25		
173-289	3		
173-290	3		
173-292	7		
173-293	3,25		
173-294	3		
173-295	3		
173-299	25		
173-348	31		
173-350	31		
173-351	31		
173-352	31		
173-355	7		
173-356	5		
173-368	5		
173-369	5		
173-370	5		
173-371	5		
173-374	25		
173-374	25		
173-376	25		
173-391	7		
173-392	23		
173-393	23		
173-394	23		
173-395	23		
173-396	21		
173-397	21		
173-398	21		
173-399	21		
173-400	21		
173-401	21		
173-402	21		
173-403	21		
173-406	21		
173-407	21		
173-408	21		
173-409	21		
173-410	21		
173-411	21		
173-413	21		

KNIGHT MANUFACTURING CORP. PO BOX 167 BROADHEAD, WI 53520
OFFICE: (608) 897-2131 PARTS/SERVICE: (608) 897-2125 FAX: (608) 897-2561