

Slinger Model 725 Tow Type

DEALER SERVICE PARTS LISTING

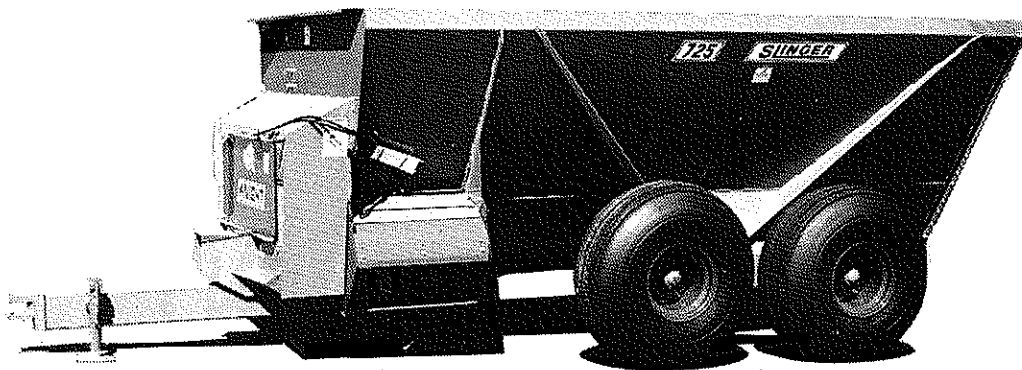

TABLE OF CONTENTS

Using This Listing.....	1
Front End Parts.....	2-5
Discharge Parts.....	6-7
Running Gear Parts.....	8-9
Rear End Parts.....	10-11
Top Guard & Auger Parts.....	12-13
540 RPM PTO Driveline.....	14
1000 RPM PTO Driveline.....	15
Decal & Paint List.....	16
Optional Kits.....	17
Flighting Terms & Dimensions.....	18
Universal Joint Repair.....	19
Hardware Listing.....	20-21

725-TOW
SERVICE PARTS

Catalog P/N 005246
R013191

ABBREVIATIONS

725-TOW R081790

Assy	Assembly
A/R	As Required
B	Bolt
Brg	Bearing
BSN	Before Serial Number
BTM	Bottom
C Bolt	Carriage Bolt
Cttr	Cotter
CV	Constant Velocity (Joint)
Dia	Diameter
ea	Each
Eq or Equiv	Equivalent
FLN	Flanged Lock Nut
FW	Flat Washer
Ga	Gauge
Gr or Grd	Grade
Hd	Head
Hyd	Hydraulic
ID	Inside Diameter
Ill or Illus	Illustration
Ind	Indicator
KW	Keyway
LH	Left Hand
LW	Lock Washer
Mtg Hrd	Mounting Hardware
NC	National Coarse
NF	National Fine
OD	Outside Diameter
Pc(s)	Piece(s)
PD	Pitch Diameter
PTO	Power Takeoff (Shaft)
Q or Qty	Quantity
Reg Mach	Regular Machine
RH	Right hand
SN	Serial Number
Sprkt	Sprocket
Sq	Square
Std	Standard
UASN	Used After Serial Number
UBSN	Used Before Serial Number

USING THIS SERVICE PARTS LISTING

725-TOW R081790

This listing uses a number indentation system to specify the parts of an assembly. Any number which is indented to the right, indicates that it is a component of the item to the upper left. Example:

<u>Part no</u>	<u>Description</u>	<u>Qty</u>
uuu-uuu	Assembly A	2
vvv-vvv	Sub-Assembly B (Component of A)	3
www-www	Component of B	5
xxx-xxx	Another Component of B	1
yyy-yyy	Sub-Assembly C (Component of A)	1
etc.		

Using this system, the sub-assemblies and their components are included if an Assembly is ordered. Similarly, the components of a sub-assembly are included if a sub-assembly is ordered.

The quantity (qty) associated with an assembly, represents the number of times an assembly could be shown in the drawing. The sub-assembly quantity however, is the number of times a sub-assembly is used to build one assembly. Similarly, the component quantity refers to the number of times a given component is found in one sub-assembly.

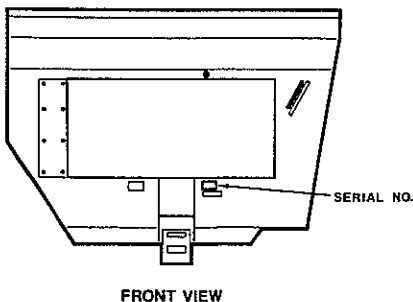

Serial Number Location
Front View
Figure A

MODEL AND SERIAL NUMBER INFORMATION is located below the drive shielding (Fig. A). The model number, serial number and part number should be known when asking service personnel for parts.

If you cannot find the part you need, be as descriptive as possible when placing an order:

Sprockets: give the bore size, number of teeth, and number and size of keyways.

Roller chain: give the size of chain (stamped on the side of each link) and number of links.

Shafting: give the diameter, length, and number and size of keyways.

Hardware is generally not included with parts. If you need any hardware, check the size, the length, and the grade (Fig. B), then check the hardware list in this manual for the part numbers. All hex head bolts up to and including 7/16" diameter are grade 5, and nuts are grade B unless otherwise stated.

The hardware listing also includes listings for zerks, cotter pins, set screws, and roller chain links.

The illustrations in this manual are meant to be used only as a guide for identifying parts and locating their relative positions.

Bolt Grades



Bolt Head Grade Markings
Figure B

A * following a part number (XXX-XXX*) indicates that the part is no longer used in production for this application. Superscript letters (XXX-XXX^A) refer to footnotes and/or illustration boxes.

FRONT END PARTS

725-TOW DR101491

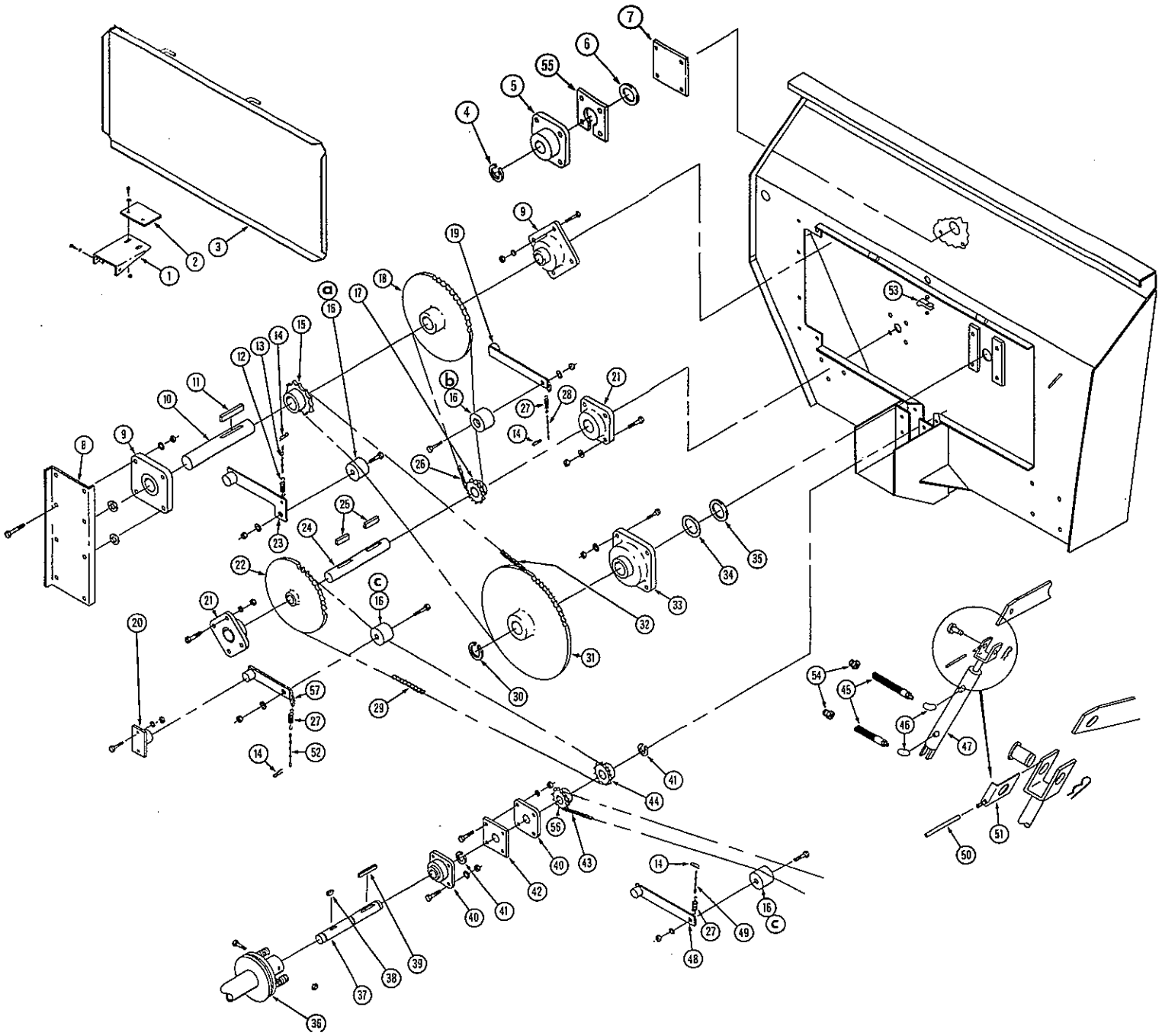

KNIGHT MANUFACTURING CORP. PO BOX 167 BRODHEAD, WI 53520
OFFICE: (608) 897-2131 PARTS/SERVICE: (608) 897-2125 FAX: (608) 897-2561

FRONT END PARTS

725-TOW DR100491

REF	PART NO	QTY	DESCRIPTION
1	133-538	1	PTO Driveline Shield Mtg Hrd: 5/16" x 3/4" Bolt, FLN & 171-393 Belleville Washer (2 ea)
2	133-539	1	PTO Driveline Shield Belt Mtg Hrd: 5/16" x 3/4" Bolt, FW & FLN (2 ea)
3	101-606	1	Front Shield Assembly
4	170-499	1	Snap Ring; 1-3/8", Truarc 5160-137 Or Equiv
5	170-000 ^B	1	Bearing; 1-3/8", FYH UCF 207-22E Or Equiv Mtg Hrd: 1/2" x 1-3/4" Bolt, LW & Nut (4 ea)
6	133-546	1	Seal; 1-3/8" ID x 2-1/2" OD
7	133-540	1	Front Cover Plate (Not Used With Upper Auger) Mtg Hrd: 1/2" x 1" Bolt, LW & Nut (4 ea)
8	133-531	1	Bearing Mount Mtg Hrd: 1/2" x 1" Bolt, LW & Nut (4 each)
9	170-053	2	Bearing; 2-1/2", FYH UCF X13-40E L-III Mtg Hrd: Outer Brg: 5/8" x 2" B, LW, Nut (4 ea) & FW (2) Inner Brg: 5/8" x 1-3/4" Bolt, LW & Nut (4 ea)
10	133-530	1	Shaft; 2-1/2" Dia
11	171-769	1	Key; 5/8" x 4-3/8"
12	172-005	1	Spring; 6" Long
13	171-592	1	Machine Chain; #4 x 46 Link
14	170-800	4	Clinch Pin
15	130-175	1	Sprocket; 120-B-12, 2-1/2" Bore, 5/8" KW
16	134-155	4	Tightener Block Mtg Hrd: 1/2" x 2-3/4" Bolt, LW, FW & Nut
a	100-748 ^{*A}	1	Idler Sprocket; 120-A-6 (Includes 170-024* Bushing), UBSN 187
b	171-273 ^{*A}	1	Idler Sprocket; 80-A-11 (Order 171-331* Spacer Bushing), UBSN 187
c	171-264 ^{*A}	2	Idler Sprocket; 60-A-15, UBSN 187
17	130-391	1	Sprocket; 80-B-13, 2" Bore, 1/2" KW
18	133-475	1	Sprocket; 80-B-54, 2-1/2" Bore, 5/8" KW
19	101-817	1	Chain Tightener Arm
19	101-579 ^{*A}	1	Tightener Arm; Sprocket Style, UBSN 187
20	101-602	1	Chain Tightener Arm Mount Mtg Hrd: 5/16" x 3/4" Bolt, LW & Nut (2 ea)
21	170-008	2	Bearing; 2", FYH UCF X10-32E L-III Or Equiv Mtg Hrd: 5/8" x 1-3/4" Tap Bolt, LW & Nut (3 ea)
22	133-476	1	Sprocket; 60-B-55, 2" Bore, 1/2" KW
23	101-832	1	Chain Tightener Arm
23	101-605 ^{*A}	1	Tightener Arm; Sprocket Style, UBSN 187
24	133-532	1	First Counter Shaft; 2" Dia
25	170-835	2	Key; 1/2" x 1-1/2"
26	170-108	1	Roller Chain; 80-1-70 Pitch, W/Connector Link
27	172-006	3	Spring; 4-5/8" Long
28	171-045	1	Machine Chain; #4 x 22 Link
29	171-766	1	Roller Chain; 60-1-94 Pitch, W/C Link (540 RPM)
29	171-767	1	Roller Chain; 60-1-89 Pitch, W/C Link (1000 RPM)

A: The current tightener blocks are very wear resistant and can be used in place of idler sprockets. In order to mount the blocks, it is necessary to modify the "sprocket style" tightener arms or replace them with the current "block style" arms.

B: The 134-378 bearing spacer was introduced in 8-90. It replaces flat spacer washers previously used.

A * following a part number (XXX-XXX*) indicates that the part is no longer used in production for this application. Superscript letters (XXX-XXX^A) refer to footnotes and/or illustration boxes.

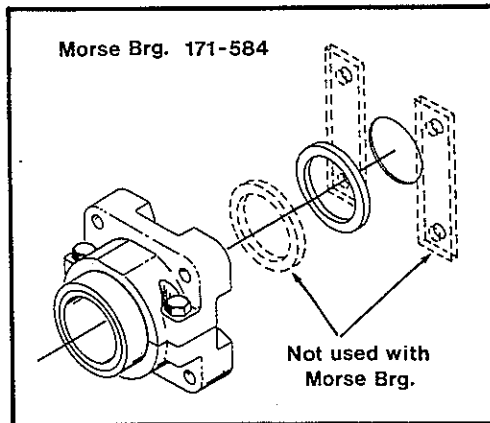
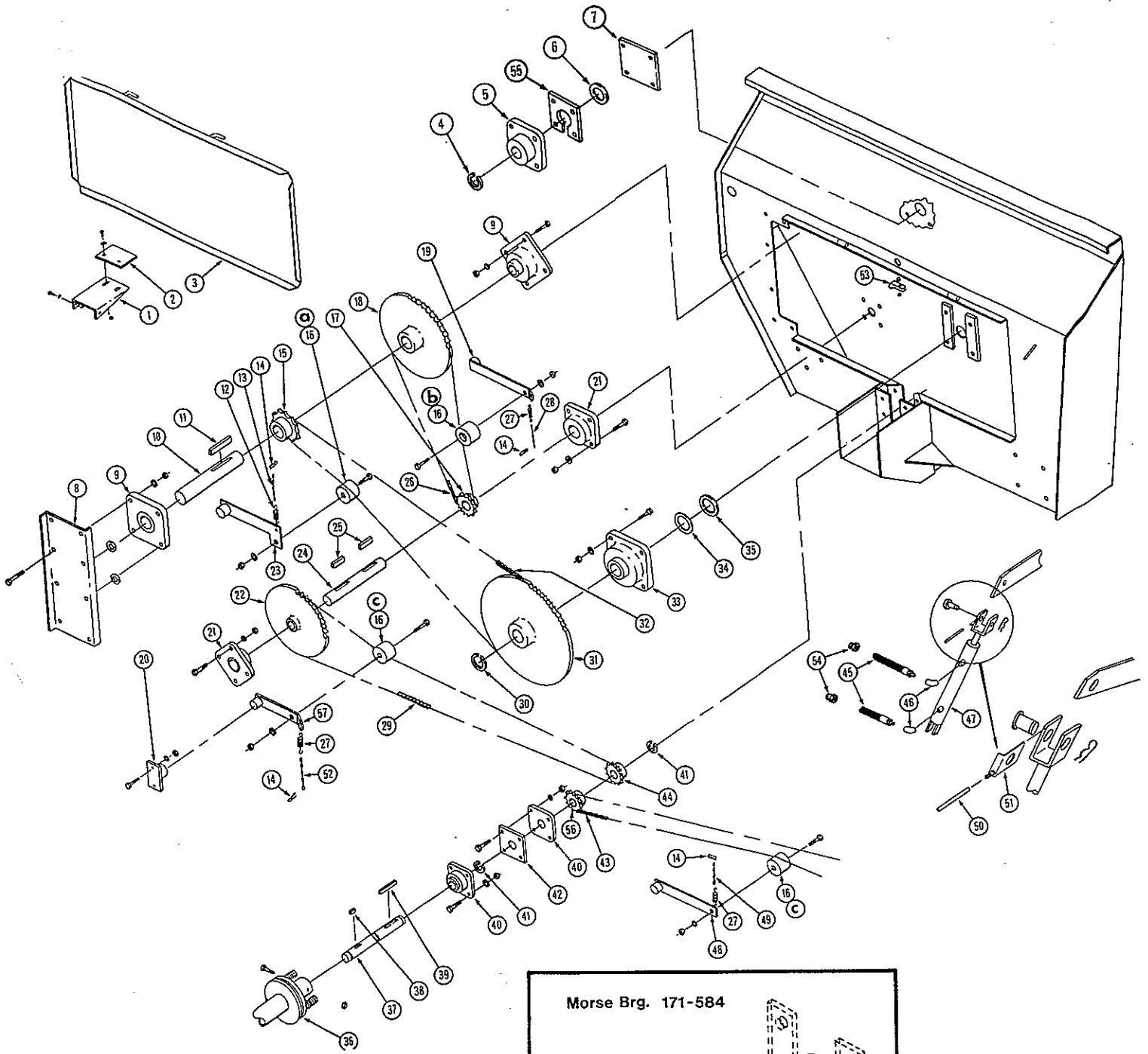

C

KNIGHT MANUFACTURING CORP. PO BOX 167 BRODHEAD, WI 53520
OFFICE: (608) 897-2131 PARTS/SERVICE: (608) 897-2125 FAX: (608) 897-2561

REF	PART NO	QTY	DESCRIPTION
30	171-607	1	Snap Ring; 3-1/2", Truarc 5100-350 Or Equiv
31	133-596	1	Sprocket; 120-B-60, 3-1/2" Splined Bore
32	171-764	1	Roller Chain; 120-1-76 Pitch, W/Connector Link
33	170-445 ^C	1	Bearing; 3-1/2", PTC 22456E Or Equiv Mtg Hrd: 3/4" x 3" Bolt, LW & Nut (4 ea)
33	171-584* ^C	1	Bearing; 3-1/2", Seal Master #RFB308-C, UBSN 217
34	134-279	1	Seal Spacer
35	133-278	1	Seal; 3-1/2" ID x 5" OD
36	171-750	1	PTO Driveline (540 RPM)
36	171-777	1	PTO Driveline (1000 RPM)
37	133-533	1	Input Shaft; 1-3/8" Dia
38	170-170	1	Key; #1210 Woodruff, 3/8" x 1-1/4"
39	170-052	1	Key; 3/8" x 2-1/8"
40	171-585	2	Bearing; 1-3/8", FYH NANF 207-22 Or Equiv Mtg Hrd: 1/2" x 1-3/4" Bolt, LW & Nut (4 ea)
41	170-499	2	Snap Ring; 1-3/8", Truarc 5160-137 Or Equiv
42	133-316	1	Bearing Spacer
43	172-293	1	Roller Chain; 60H-1-96 P., W/C Link (540 RPM)
43	171-765*	1	Roller Chain; 60H-1-89 Pitch, W/C Link (540 RPM) UBSN 471
43	172-353	1	Roller Chain; 60H-1-88 P., W/C Link (1000 RPM)
43	171-816*	1	Roller Chain; 60H-1-83 Pitch, W/C Link (1000 RPM) UBSN 471
44	133-477	1	Sprocket; 60-B-27, 1-3/8" Bore (540 RPM)
44	132-678	1	Sprocket; 60-B-15, 1-3/8" Bore (1000 RPM)
45	171-309	2	Hydraulic Hose; 1/4" x 132"
46	171-030	2	Swivel Adapter; 3/8" - 90 Degrees
47	170-232	1	Hyd Cylinder; 2-1/2" x 8" (Includes 170-073 Pins & 170-074 Hairpin Clips) (Seal Kit #170-464)
47	170-941* ^B	1	Hyd Cylinder; 2" x 8" (Seal Kit #170-075*), UBSN 187
48	101-761	1	Chain Tightener Arm
48	101-581* ^A	1	Tightener Arm; Sprocket Style, UBSN 187
49	170-479	1	Machine Chain; #4 x 9 Link
50	133-509	1	Door Height Indicator
51	101-618	1	Door Gauge Bracket
52	170-845	1	Chain; #4 x 17 Link
53	171-782	1	Clamp; Hose Holder Mtg Hrd: 5/16" Nut & FLN
54	170-235	2	Reducer Bushing; 1/2" To 3/8"
55	134-378 ^D	1	Bearing Spacer
56	134-461	1	Sprocket; 60-B-36 (540 RPM)
56	133-477*	1	Sprocket; 60-B-27 (540 RPM) UBSN 471
56	134-459	1	Sprocket; 60-B-20 (1000 RPM)
56	132-678*	1	Sprocket; 60-B-15 (1000 RPM) UBSN 471
57	101-911	1	Chain Tightener Arm
57	101-579* ^A	1	Tightener Arm; Sprocket Style UBSN 187

A: The current tightener blocks are very wear resistant and can be used in place of idler sprockets. In order to mount the blocks, it is necessary to modify the "sprocket style" tightener arms or replace them with the current "block style" arms.

B: The current 2-1/2" x 8" hydraulic cylinder can be used in place of the 2" x 8" cylinder. Some metal removal may be required. The 5" wide pivot bar is recommended with this cylinder. See P/N 134-174 in the "Discharge Parts" section.

C: The Morse (Seal Master) bearing has a two piece housing secured with bolts. The current PTC (Link-Belt) bearing has a one piece housing. The Morse bearing does not use the seal spacer or bars found with the PTC bearing (See illus. box C).

D: The 134-378 bearing spacer was introduced in 8-90. It replaces flat spacer washers previously used.

DISCHARGE PARTS

725-TOW DR092791

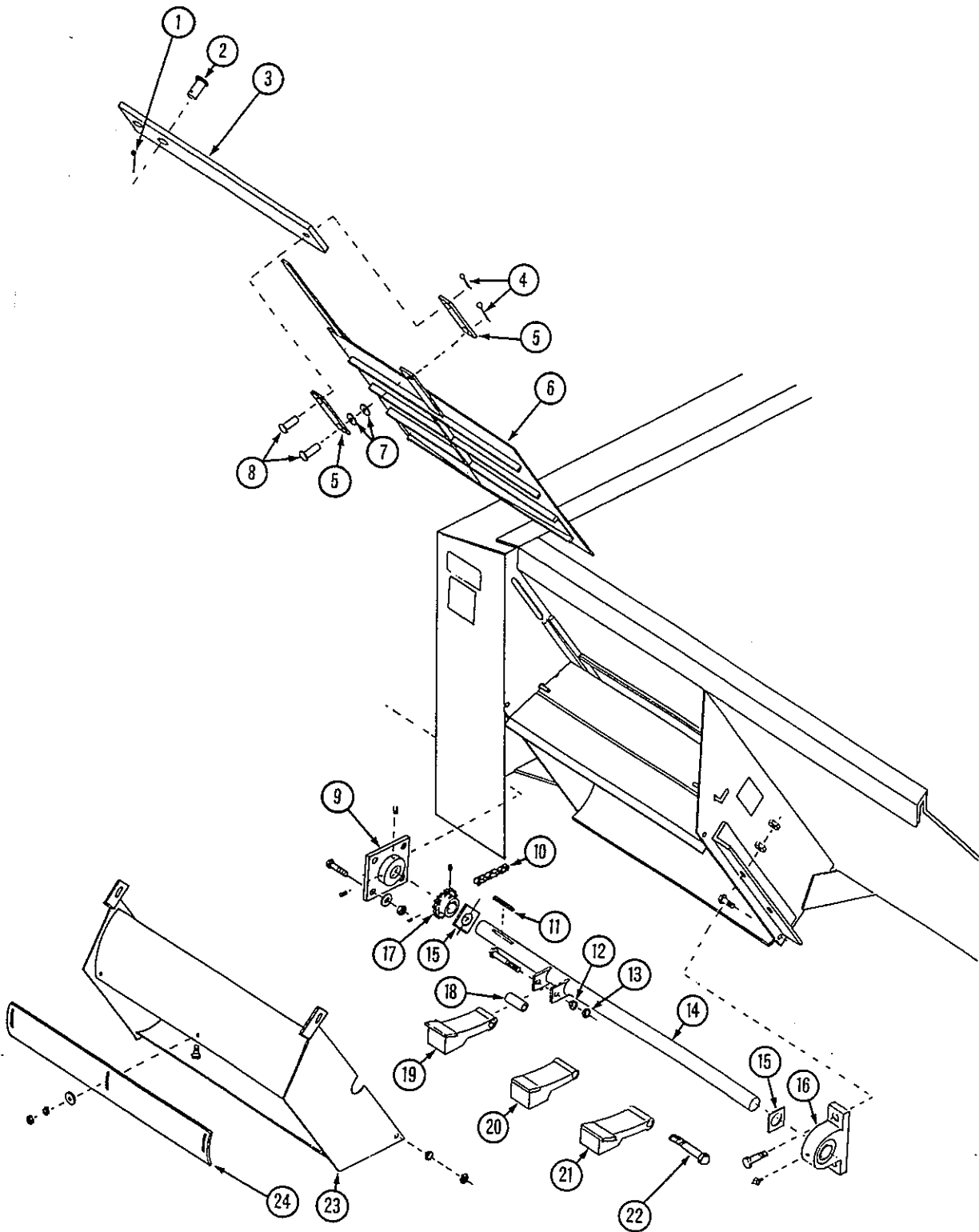

KNIGHT MANUFACTURING CORP. PO BOX 167 BRODHEAD, WI 53520
OFFICE: (608) 897-2131 PARTS/SERVICE: (608) 897-2125 FAX: (608) 897-2561

DISCHARGE PARTS

725-TOW DR102892

REF	PART NO	QTY	DESCRIPTION
1	170-074	1	Hairpin Clip
2	170-073	1	Clevis Pin; 1" Dia
3	134-174 ^A	1	Pivot Bar; 5" Wide
3	133-444 ^{*A}	1	Pivot Bar; 4" Wide, UBSN 187
4	170-236	2	Cotter Pin; 5/32" x 1-1/2"
5	133-445	2	Door Linkage Bar
6	101-583	1	Discharge Door Assembly
7	170-066	2	Flat Washer; 5/8"
8	171-696	2	Clevis Pin; 5/8" x 2"
9	170-008	1	Bearing; 2", FYH UCF X10-32E L-III Or Equiv Mtg Hrd: 5/8" x 1-3/4" Tap Bolt, LW & Nut (4 ea)
10	172-293	1	Roller Chain; 60H-1-96 P., W/C Link (540 RPM)
10	171-765 [*]	1	Roller Chain; 60H-1-89 P., W/C Link (540 RPM) UBSN 471
10	172-353	1	Roller Chain; 60H-1-88 P., W/C Link (1000 RPM)
10	171-816 [*]	1	Roller Chain; 60H-1-83 P., W/C Link (1000 RPM) UBSN 471
11	170-835	1	Key; 1/2" x 1-1/2"
12	171-671 ^E	12	Locknut; 1/2", Grade 8
13	170-036 ^E	12	Jam Nut; 1/2"
14	101-595 ^{*D}	1	Hammer Shaft Assembly (Obsolete)
	102-006	1	Hammer Shaft Assembly (Upgrade)
15	133-604	2	Belt; Shaft Seal Mtg Hrd: 1/4" x 1" Bolt, FW, LN & 171-083 FW (1 ea)
16	171-586	1	Bearing; 2" Pillow Block, FYH NAP 211-32 L-III Mtg Hrd: 5/8" x 2-1/2" Bolt, FW (2 ea) & LN (4)
17	134-460	1	Sprocket; 60-B-23, 2" Bore, 1/2" KW
17	133-395 [*]	1	Sprocket; 60-B-18, 2" Bore, 1/2" KW UBSN 471
18	133-238 ^E	12	Hammer Sleeve
19	101-548 ^C	1	Front Hammer (Tip #133-299)
20	101-586 ^C	10	Main Hammer (Tip #133-298)
21	101-549 ^C	1	Rear Hammer (Tip #133-299) Use AWS E10018 Electrode Or Greater For Welding Replacement Tips
22	171-573 ^E	12	Bolt; 1/2" x 4-1/2", 30% Stronger Than Grade 8, 180,000 PSI Minimum Tensile Strength
23	101-633	1	Door Shroud Assy; Mtg Hrd: 3/8" x 1" Bolt, LN (4 ea) & 3/8" Heavy FW (2 ea)
24	134-586 ^B	1	Shroud Visor Mtg Hrd: 5/16" x 1" Bolt, FW, LW & Nut (3 ea)

A: The current 5" wide pivot bar can be used in place of the 4" wide bar. The panel slot on units equipped with the 4" wide bar will have to be lengthened to accept the 5" wide bar.

B: The edges of the visor may need to be modified to clear welds on door shroud assemblies built before 1-1-92.

C: Use Stulz Manganese-XL or Equiv. Welding Electrodes for Hammer repair. Order Kit 300-030 - Quantity as required.

D: Hammer Shaft Assembly 101-595 is no longer a production item. When ordering a replacement Hammer Shaft Assembly, order 102-006 with:
 170-031 5/8" Grade B Lock Nut (12 ea.)
 172-422 Hammer Sleeve (12 ea.)
 172-421 Hammer Bolt, 5/8" x 5-1/2", Grade 5 (12 ea.)
 170-037 5/8" Jam Nut

E: Used with 101-595 Hammer Shaft Assembly only. Refer to (D) above for 102-006 Hammer Shaft Assembly Hardware.

An asterisk (*) at the end of a part number (XXX-XXX*) indicates that the part is no longer used in production for this application. Superscript letters (XXX-XXX^A) refer to footnotes and/or illustration boxes.

RUNNING GEAR PARTS

725-TOW R081790

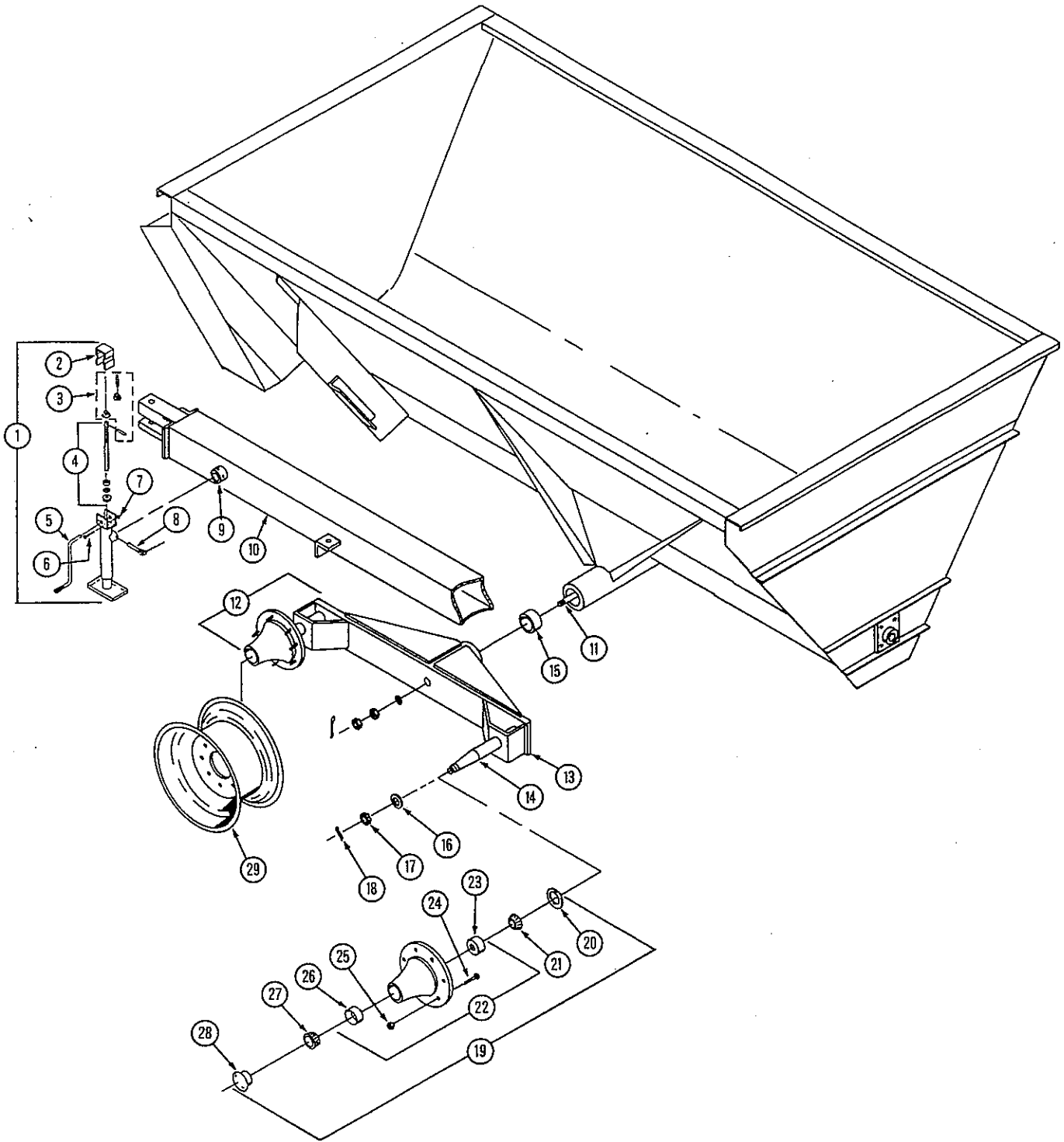

KNIGHT MANUFACTURING CORP. PO BOX 167 BRODHEAD, WI 53520
OFFICE: (608) 897-2131 PARTS/SERVICE: (608) 897-2125 FAX: (608) 897-2561

RUNNING GEAR PARTS

725-TOW DR053091

REF	PART NO	QTY	DESCRIPTION
1	171-610	1	Jackstand Assembly
2	171-814	1	Cover
3	171-614	1	Gear Kit
4	171-611	1	Screw, Nut, Bearing & Washer Assembly
5	171-612	1	Crank Assembly
6	170-509	1	Carriage Bolt; 1/4" x 3"
7	170-125	2	1/4" Nut
8	171-613	1	Pull Pin
9	171-615	1	Mount Tube Assembly
10	101-638	1	Tongue Assembly Mtg Hrd: 3/4" x 2" Grd 5 Bolt, LN (4 ea), 5/8" x 2" Bolt, LN (2 ea) & FW (4)
11	101-613	1	Tie Rod Assembly Mtg Hrd: 3/4" Nut, Jam Nut, (170-236) Cotter Pin (1 ea) & FW (2)
	101-646	1	RH Bogie Assembly
	101-644	1	RH Bogie Weldment
12	101-645	1	LH Bogie Assembly
13	101-643	1	LH Bogie Weldment
14	171-808	1	Spindle; 3"
15	133-565	1	Bushing; Bogie Pivot
16	171-832	1	Spindle Washer
17	171-833	1	Castle Nut; 1" NF
18	170-056	1	Cotter Pin; 1/4" x 2"
19	171-815	1	8-Bolt Hub Assembly
20	171-831	1	Grease Seal
21	171-828	1	Inside Bearing Cone
22	171-823	1	8-Bolt Hub
23	171-824	1	Inside Bearing Race
24	171-826	8	Wheel Stud; 5/8"
25	171-827	8	Wheel Nut; 5/8"
26	171-825	1	Outside Bearing Race
27	171-829	1	Outside Bearing Cone
28	171-830	1	Dust Cap
29	171-809	4	Wheel; 16.1" x 16", 8-Hole
29	172-229	4	Wheel; 22-1/2" x 11-1/4"

A * following a part number (XXX-XXX*) indicates that the part is no longer used in production for this application. Superscript letters (XXX-XXX^A) refer to footnotes and/or illustration boxes.

REAR END PARTS

725-TOW DR092791

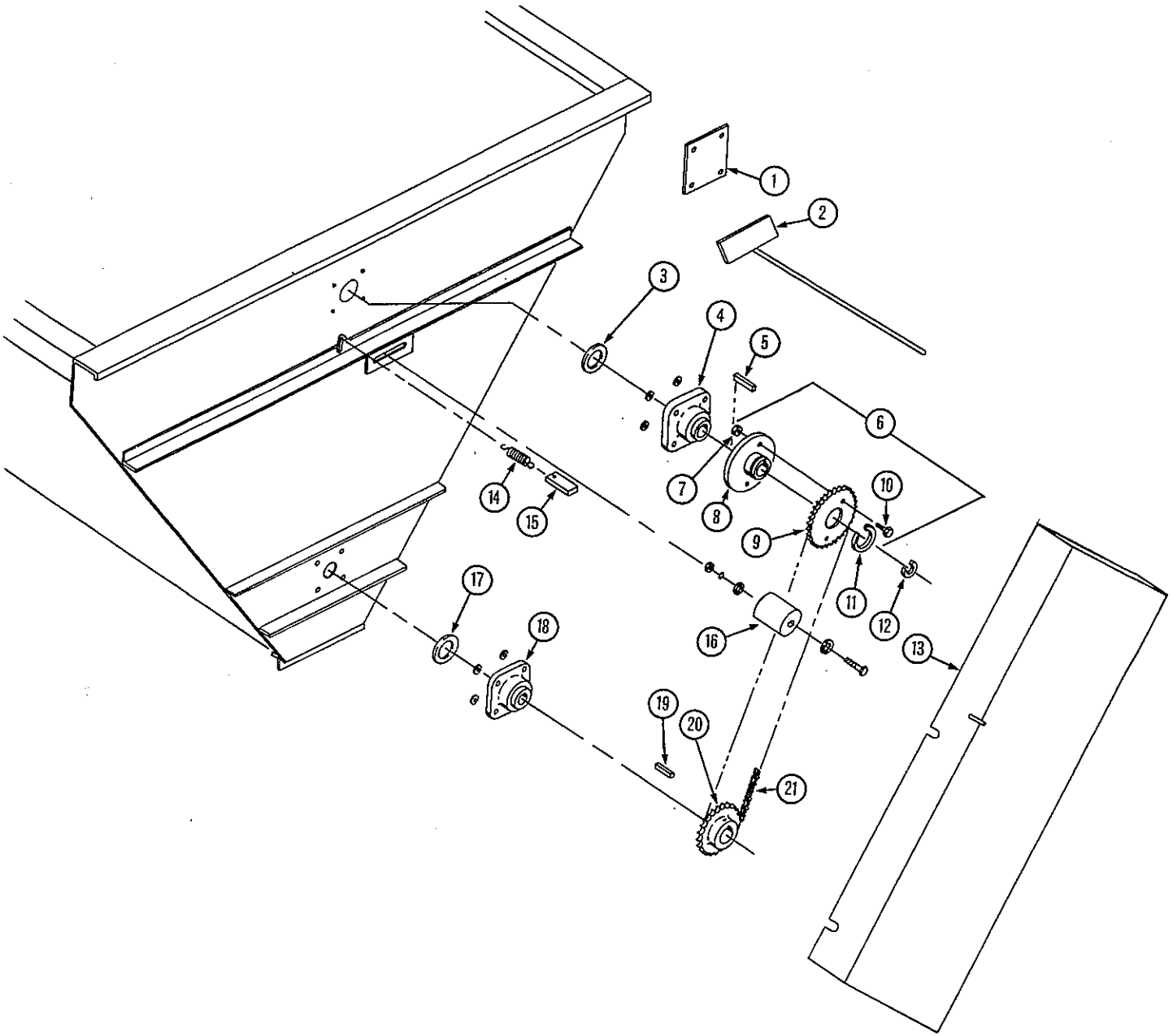

KNIGHT MANUFACTURING CORP. PO BOX 167 BRODHEAD, WI 53520
OFFICE: (608) 897-2131 PARTS/SERVICE: (608) 897-2125 FAX: (608) 897-2561

REAR END PARTS

725-TOW DR042793

REF	PART NO	QTY	DESCRIPTION
1	133-323	1	Rear Cover Plate (Not Used With Upper Auger)
2	101-636	1	Cleaning Tool
3	133-376	1	Seal; 2" ID x 3-1/2" OD
4	170-008	1	Bearing; 2", FYH UCF X10-32E L-III Or Equiv Mtg Hrd: 5/8" x 2" Bolt, LW, FW & Nut (4 ea) (Use 171-049 Spacer Washer As Required)
5	170-835	1	Key; 1/2" x 1-1/2"
6	101-955	1	Shear Sprocket Assy; Center Mt. Auger UASN 725-470
6	101-610*	1	Shear Sprocket Assembly; Side Mt. Auger UBSN 725-471
7	170-047	2	3/8" Lock Nut; UASN 725-470
7	170-028*	2	5/16" Flanged Lock Nut; UBSN 725-471
8	101-953 ^A	1	Hub; UASN 725-470
8	101-611 ^{*A}	1	Hub; UBSN 725-471
9	134-618 ^A	1	Sprocket; 80-A-54 UASN 725-470
9	133-547 ^{*A}	1	Sprocket; 80-A-30 UBSN 725-471
10	172-383	2	Bolt; 3/8" x 1-3/4", Gr 5 UASN 725-470
10	170-263*	2	Bolt; 5/16" x 1-3/4", Grade 5 UBSN 725-471
11	170-087	1	Snap Ring; 3-1/4", Truarc 5100-325 Or Equiv
12	170-361	1	Snap Ring; 2", Truarc 5160-200 Or Equiv
13	101-951	1	Shield; Center Mt. Upper Auger, UASN 725-470
13	101-640*	1	Shield; Side Mt. Upper Auger, UBSN 725-471
14	170-110	1	Spring
15	133-552	1	Belt; Spring Handle
16	134-155	1	Poly Block Mtg Hrd: 1/2" x 2-3/4" Bolt, LW, Nut (1 ea) & FW (2 ea)
16	170-880*	1	Wood Block
17	133-277	1	Seal; 2-1/2" ID x 3-1/2" OD
18	170-053	1	Bearing; 2-1/2", FYH UCF X13-40E L-III Mtg Hrd: 5/8" x 2" Bolt, LW, FW & Nut (4 ea)
19	171-618	1	Key; 5/8" x 1-1/2"
20	130-173	1	Sprocket; 80-B-15, 2-1/2" Bore, 5/8" KW
21	172-384	1	Roller Chain; 80-1-96 P, UASN 725-470
21	171-822*	1	Roller Chain; 80-1-90 P, W/C Link UBSN 725-471

A: New shear sprocket and shear hub parts may have misaligned shear bolt holes. If holes are misaligned use shear hub as a drill guide to drill holes in shear sprocket.

An asterisk (*) at the end of a part number (XXX-XXX*) indicates that the part is no longer used in production for this application. Superscript letters (XXX-XXX^A) refer to footnotes and/or illustration boxes. 11

TOP GUARD & AUGER PARTS

725-TOW DR110891

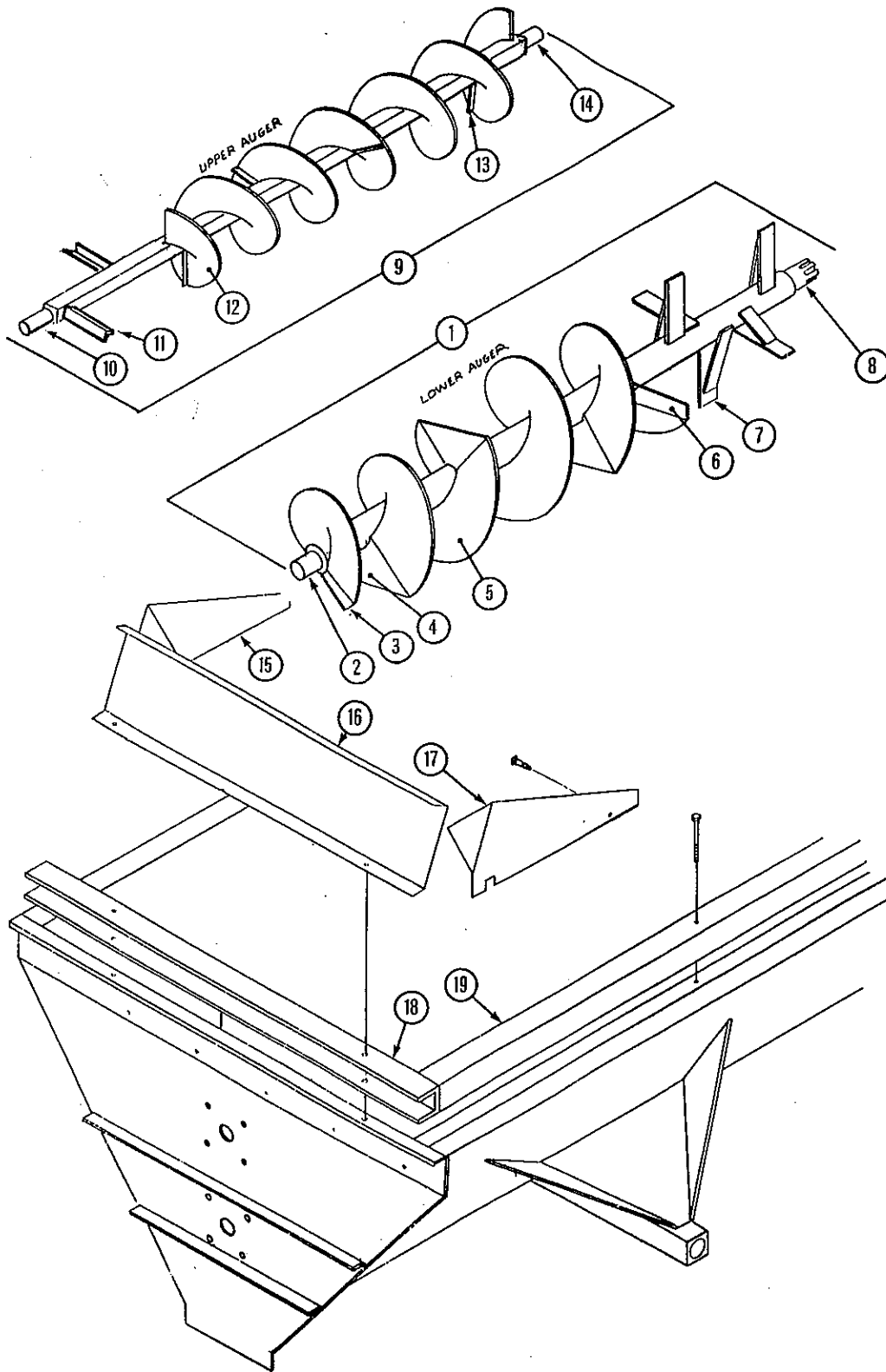

KNIGHT MANUFACTURING CORP. PO BOX 167 BRODHEAD, WI 53520
OFFICE: (608) 897-2131 PARTS/SERVICE: (608) 897-2125 FAX: (608) 897-2561

TOP GUARD & AUGER PARTS

725-TOW DR092591

REF	PART NO	QTY	DESCRIPTION
1	101-687 ^A	1	Lower Auger Assembly; 90 Degree Delayed Flight
2	101-601	1	Rear Plug Assembly
3	131-552	1	Rear Flighting Support Bar
4	133-737	5	90 Degree Flighting Delay Block
5	133-361	6	Flighting; 3/8" x 5-1/2" x 24" x 24" LH
6	133-630	1	Front Flighting Support Bar (Tapered)
7	101-596	5	Paddle Assembly
8	101-634	1	Front Plug Assembly
9	101-956	1	Upper Auger; 20" Dia. Center Mt. UASN 725-470
9	101-607*	1	Upper Auger; 16" Dia. Side Mt. UBSN 725-471
10	101-609	1	Rear Plug
11	133-545	2	Paddle (Also Used On 101-607* Upper Auger, 4 Req'd)
12	134-619	1	Flight; 5" x 20" x 20" x 137" RH (For 101-956)
12	133-544*	1	Flight; 5" x 16" x 16" x 108" RH (For 101-607*, UBSN 471)
13	134-622	4	Auger Brace
13	131-388*	4	Auger Brace (For 101-607*, UBSN 471)
14	101-608	1	Front Plug
15	133-556	1	Splash Guard Side (RH Front & LH Rear)
16	133-618	1	Splash Guard End Mtg Hrd: 5/16" x 1" Bolt, LW, Nut (7 ea) & FW (14)
17	133-557	1	Splash Guard Side (LH Front & RH Rear) Mtg Hrd: To Wood Rail: 3/8" x 3-1/2" C Bolt & Nut (4 ea) To Side Panel: 3/8" x 1" Bolt, LW & Nut (4 ea)
18	133-617	2	End Panel Extension Mtg Hrd: 5/16" x 1" Bolt, LW, Nut (3 ea), FW (8) & 3/8" x 2-1/2" Lag Screw (2)
19	133-640	2	Wood Rail; 3" x 4" x 168" Mtg Hrd: 3/8" x 4-1/2" Carriage Bolt & Nut (5 ea)

A: 3 different auger versions have been used: the 180 degree delayed flight, the 90 degree delayed flight, and the full flighted auger. The 90 degree delayed flight auger has proven to be the most versatile. All three versions use the same components except for the delay blocks. For parts, refer to the auger listed above and consult Knight Mfg. to determine the best method of repair.

A * following a part number (XXX-XXX*) indicates that the part is no longer used in production for this application. Superscript letters (XXX-XXX^A) refer to footnotes and/or illustration boxes.

FRICITION CLUTCH PTO DRIVELINE - 540 RPM

725-TOW DR080891

REF	PART NO	QTY	DESCRIPTION
1	171-750	1	14NW 9000 Friction Clutch PTO Driveline Mtg Hrd: 1/2" x 3" Bolt & LN
2	171-752	1	Joint & Friction Clutch With Shield
4	170-047	6	Stopnut
5	171-762	6	Washer
6	171-761	6	Spring
7	171-759	1	Pressure Plate
8	171-760	2	Friction Disc
9	171-758	1	Drive Hub
10	171-757	1	Clutch Yoke W/Plate
11	171-813	6	Bolt; 3/8" x 4-1/4"
12	170-720	1	Repair Kit
13	171-754	1	Yoke & Tube
14	171-755	1	Male Shield Assy
15	170-219	1	Bearing Retainer
16	170-220	1	Nylon Bearing
17	171-751	1	Joint & Shaft with Shield
18	171-756	1	Female Shield Assy
19	170-219	1	Bearing Retainer
20	170-220	1	Nylon Bearing
21	171-753	1	Yoke & Shaft Assy
22	170-720	1	Repair Kit
23	172-018	1	Lock Yoke Assy
24	172-019 ^A	1	Spring Lock Repair Kit

A: The manual slide lock repair kit (171-529*) is obsolete. Order the 172-018 lock yoke assembly.

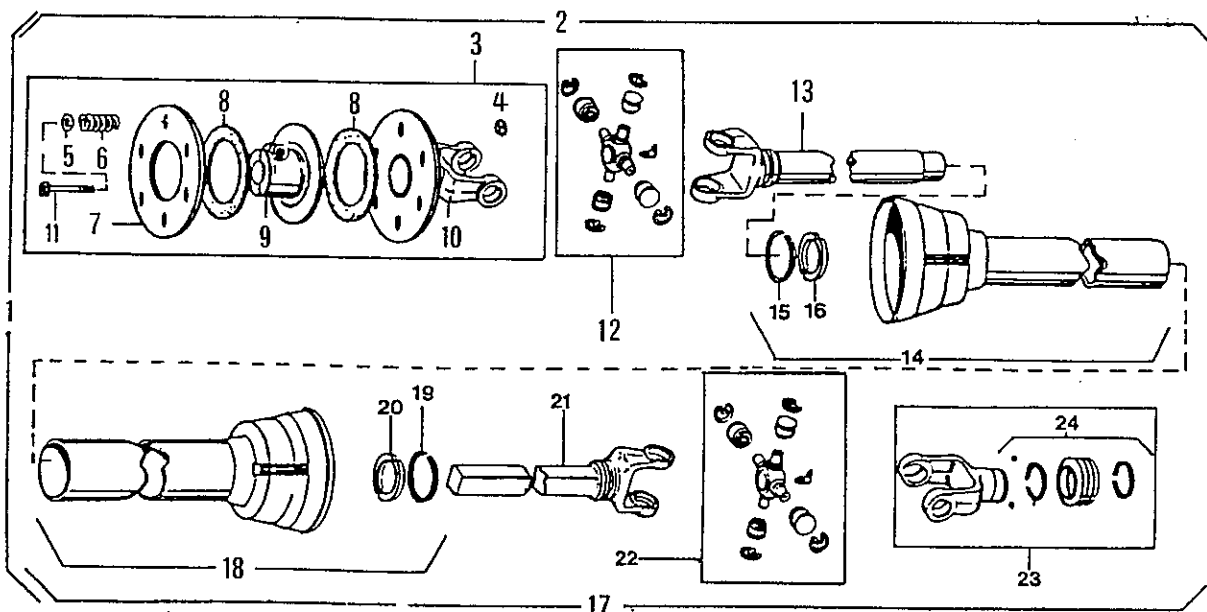

KNIGHT MANUFACTURING CORP. PO BOX 167 BRODHEAD, WI 53520
 OFFICE: (608) 897-2131 PARTS/SERVICE: (608) 897-2125 FAX: (608) 897-2561

FRICITION CLUTCH PTO DRIVELINE - 1000 RPM

725-TOW DR080891

REF	PART NO	QTY	DESCRIPTION
1	171-777	1	14NW 9000 Friction Clutch PTO Driveline Mtg Hrd: 1/2" x 3" Bolt & LN
2	171-752	1	Joint & Friction Clutch With Shield
4	170-047	6	Stopnut
5	171-762	6	Washer
6	171-761	6	Spring
7	171-759	1	Pressure Plate
8	171-760	2	Friction Disc
9	171-758	1	Drive Hub
10	171-757	1	Clutch Yoke W/Plate
11	171-813	6	Bolt; 3/8 x 4-1/4"
12	170-720	1	Repair Kit
13	171-754	1	Yoke & Tube
14	171-755	1	Male Shield Assy
15	170-219	1	Bearing Retainer
16	170-220	1	Nylon Bearing
17	171-778	1	Joint & Shaft with Shield
18	171-756	1	Female Shield Assy
19	170-219	1	Bearing Retainer
20	170-220	1	Nylon Bearing
21	171-753	1	Yoke & Shaft Assy
22	170-720	1	Repair Kit
23	172-022	1	Lock Yoke Assy
24	172-019 ^A	1	Spring Lock Repair Kit

A: The manual slide lock repair kit (171-529*) is obsolete. Order the 172-022 lock yoke assembly.

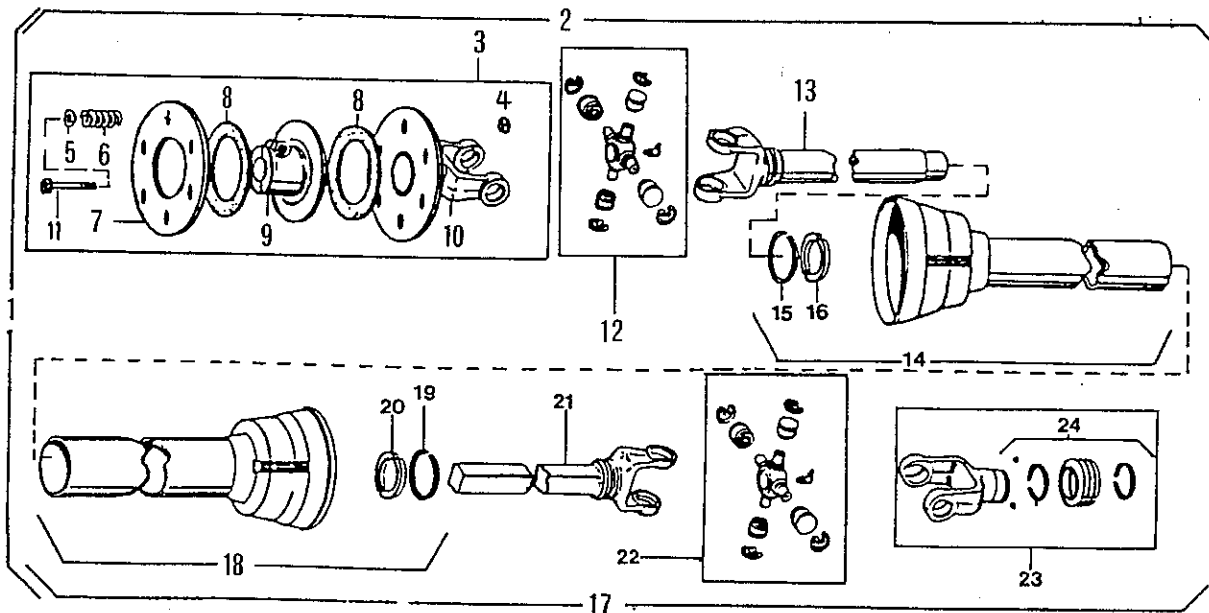

A * following a part number (XXX-XXX*) indicates that the part is no longer used in production for this application. Superscript letters (XXX-XXX^A) refer to footnotes and/or illustration boxes.

DECAL & PAINT LIST

725-TOW DR091691

The following decals are listed below for your convenience.
Use the operator's manual for decal location, part number and ordering.

Unit Decals:

PART NO	QTY	DESCRIPTION
171-846	1	Set Of Decals
170-154	2	"KNIGHT"
170-155	2	Knight Head
170-490	1	Important - Reduce Engine Speed . . .
170-849	2	Beware Of Power Driven Parts
170-893	1	Slow Moving Vehicle Decal
171-598	2	"Slinger"
171-712	1	NOTICE - Retighten Set Screws . . .
172-370	1	NOTICE - Friction Clutch Adjustment
171-748	1	Door Position
171-820	2	DANGER - Rotating Auger Inside . . .
171-821	2	DANGER - Material Discharges . . .
171-838	2	"725"
171-912	1	Caution - Be Sure To Operate . . .
171-913	1	WARNING - Do Not Operate . . .
171-915	1	Shield Missing . . . (Order a separate 171-915 If You Have The Upper Auger Option)
171-950	1	"U.S. Patent No. . . ."
171-992	2	Red Reflector
172-171	1	CAUTION - Read Operator's Manual

PTO Driveline Decals:

171-550	1	DANGER, PTO . . .
171-599	1	Do Not Exceed 540 RPM . . . (540 RPM PTO ONLY)
171-609	1	Do Not Exceed 1000 RPM . . . (1000 RPM PTO ONLY)
171-799	1	DANGER - Shield Missing

Paint:

170-366	Knight Yellow Aerosol Can
170-812	Knight Yellow Quart Can
170-813	Knight Yellow Gallon Can
170-367	Knight Red Aerosol Can
170-814	Knight Red Quart Can
170-815	Knight Red Gallon Can

OPTIONAL KITS

725-TOW R081790

Safety Chain For Towed Equipment P/N 172-041

This chain is designed to retain the connection between the towing and towed machines in the event of separation of the primary attaching system. It should be used whenever the unit is transported on the highway.

Light Kit For Towed Equipment

This light kit is designed for lighting and marking of agricultural field equipment whenever the equipment is on a highway. This kit is pre-assembled, and it includes mounting hardware.

PART NO	QTY	DESCRIPTION
300-007	1	Complete Light Kit - Assembled
172-173	2	Red And Amber Light Assembly
172-174	25'	4 Conductor Wire
172-175	1	4 Pin In-Line Connector (Male & Female)
Options:		
172-110	1	7 Pin Female Connector

FLIGHTING TERMS AND DIMENSIONS

725-TOW R081790

OUTSIDE DIAMETER: Outside diameter can be determined by laying the flight on a flat surface and measuring from the top to the base.
NOTE: Dimensions may vary slightly.

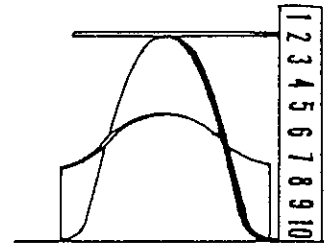

THICKNESS: Thickness of flighting can be determined with any linear measuring instrument.

INSIDE DIAMETER: To find the inside diameter of flight, measure the distance from the inside of the flight to the peak. Then multiply the dimension by two and subtract the answer from the outside diameter dimension.

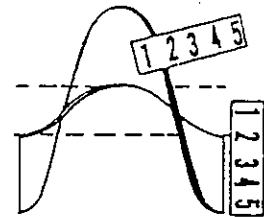

PITCH: Pitch is the dimension from one peak to the next, measured along the axis of the shaft. The term full pitch means that the outside diameter and the pitch are the same.

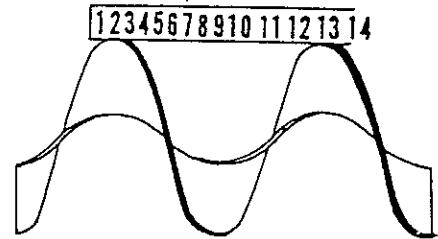

RIGHT HAND AND LEFT HAND FLIGHTING: As you look at the face of flighting and it is slanting downward to the right; it is right hand and if it is slanting downward to the left; it is left hand.

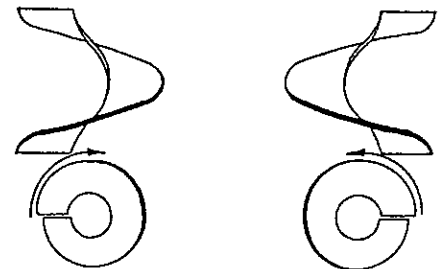

Flighting dimensions are written in a series similar to the following:

1/4" - 4" - 14" - 14"
Thick - I.D. - O.D. - Pitch

UNIVERSAL JOINT REPAIR PROCEDURE

725-TOW R081790

DISASSEMBLY PROCEDURE:

1. Remove the four snap rings as shown in Figure #1.
2. Position the joint in an open vise, with each ear of one yoke supported by a vise jaw. Figure #2
3. With a soft hammer or mallet, strike the top ear of the unsupported yoke as indicated by the arrow in Figure #2. This will drive the top bushing outward approximately 3/8 of an inch.
4. Grip the loosened bushing in the vise as shown in Fig. #3. Drive the yoke off the bushing by striking the yoke ear with a mallet in the direction of the arrow. (Fig. #3)
5. This same procedure should be followed to remove the bushing that is directly opposite the one in Step 4. After this, the yoke itself may be removed.
6. To remove the remaining two bushings, support the cross as shown in Figure #4. Make certain that the vise jaws are covered with brass protectors. By striking the yoke ear as indicated by the arrow in Figure #4, the remaining bushings can be removed by repeating the procedure called for in Step 4.

ASSEMBLY PROCEDURE:

DURING REASSEMBLY, BE SURE THAT THERE IS NO DIRT ON THE TRUNNIONS OF THE CROSS OR IN THE BUSHINGS!

1. Start one bushing in the yoke ear and position the center cross through the yoke. Drive the first bushing down flush with the outside surface of the ear as shown in Fig. #5. Support the underside of the ear so as not to spring the yoke.
2. Clamp the ear in the vise as shown in Figure #6. Use a punch of the same diameter as the bushing, drive the bushing past the snap ring groove, and insert a snap ring.
3. Position the cross and drive in the opposite bushing as described in Steps 1 & 2, and Insert a snap ring.
4. Assemble the second yoke in the same manner.
5. To insure proper seating, and to eliminate any possible tightness, strike the forged surfaces of the yoke ears with a mallet. This will insure a free flexing joint.
6. Lubricate with a good grade of multipurpose grease.

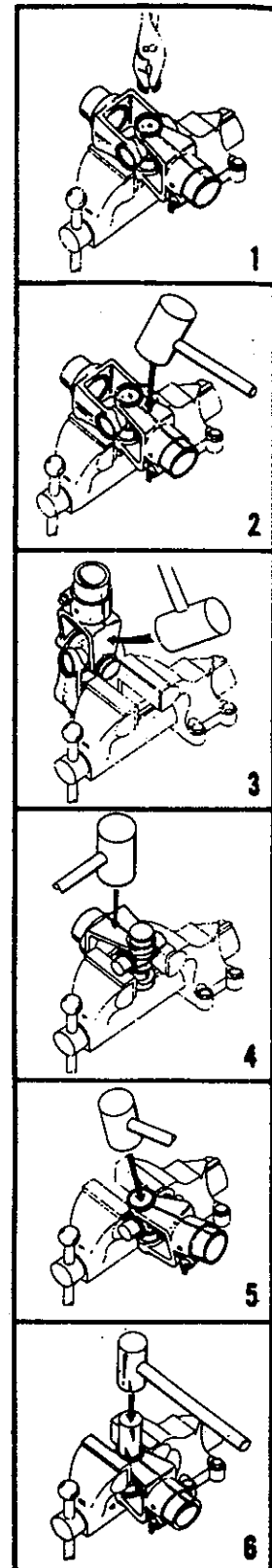

HARDWARE PART NUMBER LISTING

725-TOW R081790

All hex head bolts up to and including 7/16" dia are grade 5 unless otherwise specified. All fasteners are NC thread unless otherwise specified.

<u>Size</u>	<u>Hex Nuts</u>	<u>Locknuts</u>	<u>Jam Nuts</u>	<u>Flt Wsh.</u>	<u>Lk Wsh.</u>
#10	171-606			171-525	171-605
1/4	170-125	170-069		170-301	170-124
5/16	170-119	170-028		170-127	170-118
3/8	170-007	170-047	170-022	170-244	170-006
7/16	170-062	170-239	170-046	170-138	170-061
1/2	170-004	170-042	170-036	170-040	170-003
5/8	170-011	170-031	170-037	170-066	170-010
3/4	170-017	170-185	170-035	170-015	170-016
7/8				170-131	172-003
1				170-122	171-021

HEX HEAD BOLTS

<u>Bolt Size</u>	<u>Part No</u>	<u>Bolt Size</u>	<u>Part No</u>	<u>Bolt Size</u>	<u>Part No</u>
1/4 x 3/4	170-803	3/8 x 3	170-380	5/8 x 1-3/4	170-030
1/4 x 7/8	171-094	3/8 x 3-1/2	170-292	(Tap Bolt - Grade 5)	
1/4 x 1	170-310	3/8 x 4	170-877	5/8 x 2	170-009
1/4 x 1-1/2	170-068	3/8 x 4-1/2	170-519	(Grade 5)	
1/4 x 2-3/4	171-203	3/8 x 5	170-493	5/8 x 2	171-772
1/4 x 3	171-403	3/8 x 5-1/2	170-593	(Tap Bolt)	
5/16 x 5/8	170-532	3/8 x 6-1/2	171-291	5/8 x 2-1/2	170-129
5/16 x 3/4	170-262	7/16 x 3/4	170-265	(Tap Bolt)	
5/16 x 7/8	170-256	7/16 x 1	170-032	5/8 x 3	170-258
5/16 x 1	170-027	7/16 x 1-1/4	170-354	5/8 x 3-1/2	170-038
5/16 x 1-1/4	170-188	7/16 x 1-1/2	170-059	5/8 x 4	170-371
5/16 x 1-1/2	170-372	7/16 x 2	170-356	5/8 x 4-1/2	170-067
5/16 x 1-3/4	170-263	7/16 x 2-1/2	170-379	5/8 x 5	170-065
5/16 x 2	170-376	7/16 x 3	170-270	5/8 x 6	170-381
5/16 x 2-1/2	170-369	7/16 x 5-1/2	170-377	5/8 x 9-1/2	171-039
5/16 x 3	170-295	7/16 x 6	170-378	3/4 x 2	170-058
5/16 x 3-1/4	171-639	1/2 x 3/4	171-252	3/4 x 2-1/4	171-275
5/16 x 4	170-293	1/2 x 1	170-149	3/4 x 2-1/2	170-374
(Tap Bolt)		1/2 x 1-1/4	170-373	3/4 x 3	170-014
5/16 x 4-1/2	170-294	1/2 x 1-1/2	170-002	3/4 x 3-1/2	170-195
3/8 x 3/4	170-439	1/2 x 2	170-050	3/4 x 4	170-419
3/8 x 7/8	170-268	1/2 x 2-1/2	170-319	3/4 x 4-1/2	170-846
3/8 x 1	170-054	1/2 x 3	170-168	(Grade 5)	
3/8 x 1-1/4	170-005	1/2 x 4	171-509	3/4 x 6	171-116
3/8 x 1-1/2	170-368	1/2 x 4-1/2	171-573	(Grade 5)	
3/8 x 2	170-245	1/2 x 5	171-412		
3/8 x 2-1/4	170-320	5/8 x 1 (G.5)	171-087		
3/8 x 2-1/2	170-257	5/8 x 1-1/4	171-366		

KNIGHT MANUFACTURING CORP. PO BOX 167 BRODHEAD, WI 53520

OFFICE: (608) 897-2131 PARTS/SERVICE: (608) 897-2125 FAX: (608) 897-2561

HARDWARE LISTING CONTINUED

725-TOW R081790

TRUSS HEAD BOLTS

<u>Bolt Size</u>	<u>Part No</u>
#8 x 1-1/2	171-210
#10 x 3/4	171-604
1/4 x 1/2	170-123
1/4 x 3/4	170-193
1/4 x 1	170-194
5/16 x 1 (Grade 5)	170-117

CARRIAGE BOLTS

<u>Bolt Size</u>	<u>Part No</u>
1/4 x 1-1/2	170-355
1/4 x 2-1/2	171-394
1/4 x 3	170-509
5/16 x 1	170-370
5/16 x 2-1/2	171-395
5/16 x 5-1/2	170-494
3/8 x 3-1/2	171-283
3/8 x 4-1/2	170-191
3/8 x 5	170-495
3/8 x 6-1/2	171-174
3/8 x 8	170-297
1/2 x 6-1/2	171-098
1/2 x 9	171-255

ZERKS

<u>Size</u>	<u>Part No</u>
1/4-28	170-023
1/4-28 - 45	170-148
1/4-28 - 90	170-049
1/4 NPT	170-277
1/8 NPT	170-865
1/8 NPT-45	170-864
1/8 NPT-65	170-215
1/8 NPT-90	170-866

COTTER PINS

<u>Size</u>	<u>Part No</u>
1/16 x 1/2	170-992
3/32 x 3/4	170-364
1/8 x 3/4	170-177
1/8 x 1	170-045
1/8 x 1-1/4	170-033
1/8 x 1-1/2	170-382
5/32 x 1	170-421
5/32 x 1-1/2	170-236
5/32 x 3	170-135
3/16 x 1-1/4	170-991
3/16 x 2	170-115
1/4 x 1-1/2	170-521
1/4 x 2	170-056

SET SCREWS

<u>Size</u>	<u>Part No</u>
1/4 x 1/4 NC	170-247
5/16 x 5/16NC	170-248
5/16 x 1/2 NC	170-254
5/16 x 1/4 NF	170-993
5/16 x 5/16NF	170-825
5/16 x 5/8 NF	170-456
3/8 x 1/4 NC	170-856
3/8 x 3/8 NC	170-151
3/8 x 1/2 NC	170-857
(nylock)	
3/8 x 3/4 NC	170-289
(sq head)	
3/8 x 3/4 NC	170-290
(sq hd drilled)	
3/8 x 1 NC	170-021
3/8 x 1/2 NF	171-469
7/16 x 7/16NC	170-288
7/16 x 1 NC	170-147
(sq head)	
1/2 x 5/8 NC	170-249
1/2 x 1 NC	170-438
1/2 x 1-1/4NC	171-085
(half dog point)	
5/8 x 5/8 NC	170-250

ROLLER CHAIN
CONNECTOR LINKS

<u>Size</u>	<u>Part No</u>
#50-2R	170-094
#50	170-088
#60-2R	170-095
#60	170-089
#60H	171-102
#80	170-090
#80H	170-821
#100	170-091
#100H	171-969
#120	170-092
#140	170-093
#160	170-888

OFFSET LINKS

<u>Size</u>	<u>Part No</u>
#50	170-096
#60-2R	170-103
#60	170-097
#80	170-098
#80H	170-820
#100	170-099
#120	170-100
#140	170-101
#160	170-887

ROLLER LINKS

<u>Size</u>	<u>Part No</u>
#50	171-415
#60	171-416
#80	171-417
#80H	170-795
#120	171-419
#140	171-420

PART NUMBER INDEX

725-TOW R081790

<u>Part No</u>	<u>Page</u>	<u>Part No</u>	<u>Page</u>	<u>Part No</u>	<u>Page</u>
100-748*	3	133-278	5	170-008	3, 7, 11
101-548	7	133-297	7	170-024*	3
101-549	7	133-298	7	170-028	11
101-579*	3	133-299	7	170-036	7
101-581*	5	133-316	5	170-047	14, 15
101-583	7	133-323	11	170-052	5
101-586	7	133-361	13	170-053	3, 11
101-595	7	133-376	11	170-066	7
101-596	13	133-395	7	170-073	5, 7
101-601	13	133-444*	7	170-074	5, 7
101-602	3	133-445	7	170-075*	5
101-605*	3	133-475	3	170-087	11
101-606	3	133-476	3	170-108	3
101-607	13	133-477	5	170-110	11
101-608	13	133-509	5	170-125	9
101-609	13	133-530	3	170-154	16
101-610	11	133-531	3	170-155	16
101-611	11	133-532	3	170-170	5
101-613	9	133-533	5	170-219	14, 15
101-618	5	133-538	3	170-220	14, 15
101-633	7	133-539	3	170-232	5
101-634	13	133-540	3	170-235	5
101-636	11	133-544	13	170-236	7, 9
101-638	9	133-545	13	170-263	11
101-640	11	133-546	3	170-361	11
101-643	9	133-547	11	170-366	16
101-644	9	133-552	11	170-367	16
101-645	9	133-556	13	170-445	5
101-646	9	133-557	13	170-464	5
101-687	13	133-565	9	170-479	5
101-761	5	133-596	5	170-490	16
101-817	3	133-604	7	170-499	3, 5
101-832	3	133-617	13	170-509	9
130-173	11	133-618	13	170-720	14, 15
130-175	3	133-630	13	170-800	3
130-391	3	133-640	13	170-812	16
131-388	13	133-737	13	170-813	16
131-552	13	134-155	3	170-814	16
132-678	5	134-174	7	170-815	16
133-238	7	134-279	5	170-835	3, 7, 11
133-277	11	170-000	3	170-845	5

PART NUMBER INDEX - CONT.

725-TOW R081790

<u>Part No</u>	<u>Page</u>	<u>Part No</u>	<u>Page</u>	<u>Part No</u>	<u>Page</u>
170-849	16	171-758	14, 15	172-005	3
170-880	11	171-759	14, 15	172-006	3
170-893	16	171-760	14, 15	172-018	14
170-941*	5	171-761	14, 15	172-019	14, 15
171-030	5	171-762	14, 15	172-022	15
171-045	3	171-764	5	172-041	17
171-049	11	171-765	5, 7	172-110	17
171-083	7	171-766	5	172-171	16
171-264*	3	171-767	5	172-173	17
171-273*	3	171-769	3	172-174	17
171-309	5	171-777	5, 15	172-175	17
171-331*	3	171-778	15	300-007	17
171-393	3	171-782	5		
171-550	16	171-799	16		
171-573	7	171-808	9		
171-584*	5	171-809	9		
171-585	5	171-813	14, 15		
171-586	7	171-814	9		
171-592	3	171-815	9		
171-598	16	171-816	5, 7		
171-599	16	171-820	16		
171-609	16	171-821	16		
171-610	9	171-822	11		
171-611	9	171-823	9		
171-612	9	171-824	9		
171-613	9	171-825	9		
171-614	9	171-826	9		
171-615	9	171-827	9		
171-618	11	171-828	9		
171-671	7	171-829	9		
171-696	7	171-830	9		
171-712	16	171-831	9		
171-746	16	171-832	9		
171-748	16	171-833	9		
171-750	5, 14	171-834	9		
171-751	14	171-838	16		
171-752	14, 15	171-846	16		
171-753	14, 15	171-912	16		
171-754	14, 15	171-913	16		
171-755	14, 15	171-915	16		
171-756	14, 15	171-950	16		
171-757	14, 15	171-992	16		