



KNIGHT

TRAILER PARTS MANUAL FOR PRO TWIN SLINGER MODELS 8018 / 8024

TABLE OF CONTENTS

Abbreviations	2
Using This Listing	3
Front End Parts	4-5
Front Drive Parts	6-9
Discharge Parts	10-11
Running Gear Parts 8018 (<i>sn 1857 and after</i>)	12-13
Running Gear Parts 8024	14-15
Running Gear Parts 8018 (<i>sn 1856 and before</i>)	16-17
Rear Parts	18-19
Auger & Splash Guard Parts	20-21
Lid Parts	22
PTO Driveline	23-39
Decal & Paint List	40
Light kit	40
Hardware Part Number Listing	41-42
Part Number Index	43-44

Catalog Part Number 005816

Unit Serial Number _____

Operator Instruction Manual for this unit: 005568

ABBREVIATIONS

Assy	Assembly
A/R	As Required
B	Bolt
Brg	Bearing
BSN	Before Serial Number
Btm	Bottom
C-Bolt	Carriage Bolt
Cttr	Cotter
CV	Constant Velocity
Deg	Degree
Dia	Diameter
ea	Each
eq or Equiv	Equivalent
Fln	Flanged Lock Nut
Fw	Flat Washer
Ga	Gauge
Gr or Grd	Grade
Hd	Head
Hfw	Heavy Flat Washer
Hyd	Hydraulic
ID	Inside Diameter
Ill or Illus	Illustration
Ind	Indicator
Jn	Jam Nut
Kw	Keyway
LH	Left Hand
Ln	Lock Nut
Lw	Lock Washer
Mtg Hrd	Mounting Hardware
NC	National Coarse
NF	National Fine
NLA	No Longer Available
NPT	National Pipe Thread
OD	Outside Diameter
Pc(s)	Piece(s)
PD	Pitch Diameter
PTO	Power Takeoff (shaft)
Qty	Quantity
RH	Right Hand
SN	Serial Number
SHCS	Socket Head Cap Screw
Spk, or Spkt or Sprkt	Sprocket
Sq	Square
SS	Stainless Steel
SSB	Stainless Steel Bolt
St	Straight
Std	Standard
STS	Self Tapping Screw
UASN	Used After Serial Number
UBSN	Used Before Serial Number
W	With
W/O	With Out

USING THIS SERVICE PARTS LISTING

This listing uses a number indentation system to specify the parts of an assembly. Any number which is indented to the right, indicates that it is a component of the item to the upper left. Example:

<u>Part no</u>	<u>Qty</u>	<u>Description</u>
102-AAA	#	Assembly A
102-BBB	#	Sub-Assembly B
(Component of A)		
140-xxx	#	Sub-Component of B
140-xxx	#	Sub-Component of B
102-CCC	#	Sub-Assembly C
(Component of A)		
etc.		

Using this system, the subassemblies and their components are included if an **Assembly** is ordered. Similarly, the components of a subassemblies are included if a subassembly is ordered.

The quantity (Qty) associated with an assembly, represents the number of times an assembly could be shown in the drawing. The subassembly quantity however, is the number of times a subassembly is used to build one assembly. Similarly, the component quantity refers to the number of times a given component is found in one subassembly.

MODEL AND SERIAL NUMBER INFORMATION is located near the front left hand corner (Fig. A). The model number, serial number and part number should be known when asking service personnel for parts.

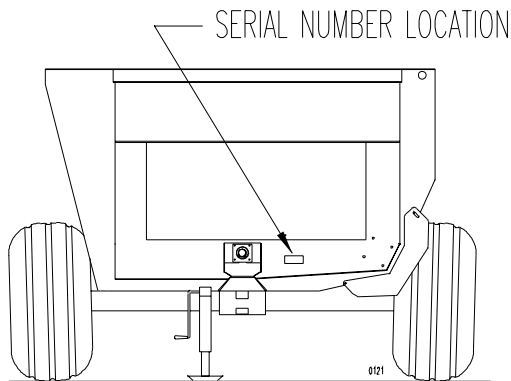

Fig. A

The serial number may consist of a number, or a number with a letter prefix. When referring to serial number breaks in the text of this manual, a serial number with a prefix will have been manufactured after a serial number without a prefix (A001 made after 0123). Likewise, a higher prefix letter would indicate manufacture after a lower prefix letter (B001 made after A123). Therefore, if the text refers to units manufactured after serial number B123, this would include "B" series numbers greater than 123, and all numbers with a higher letter prefix.

If you cannot find the part you need, be as descriptive as possible when placing an order:

Sprockets: give the bore size, number of teeth, and size of keyway.

Roller chain: give the size of chain (stamped on the side of each link) and number of links.

Shafting: give the diameter, length, and quantity and size of keyways.

Hardware is generally not included with parts. If you need any hardware, check the size, the length, and the grade (Fig. B), then check the hardware list in this manual for the part numbers.

All hex head bolts are grade 5, and nuts are grade 5 unless otherwise stated.

The hardware listing also includes zerks, cotter pins, set screws, and roller chain links.

The illustrations in this manual are meant to be used only as a guide for identifying parts and locating their relative positions.

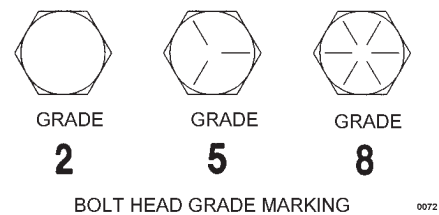
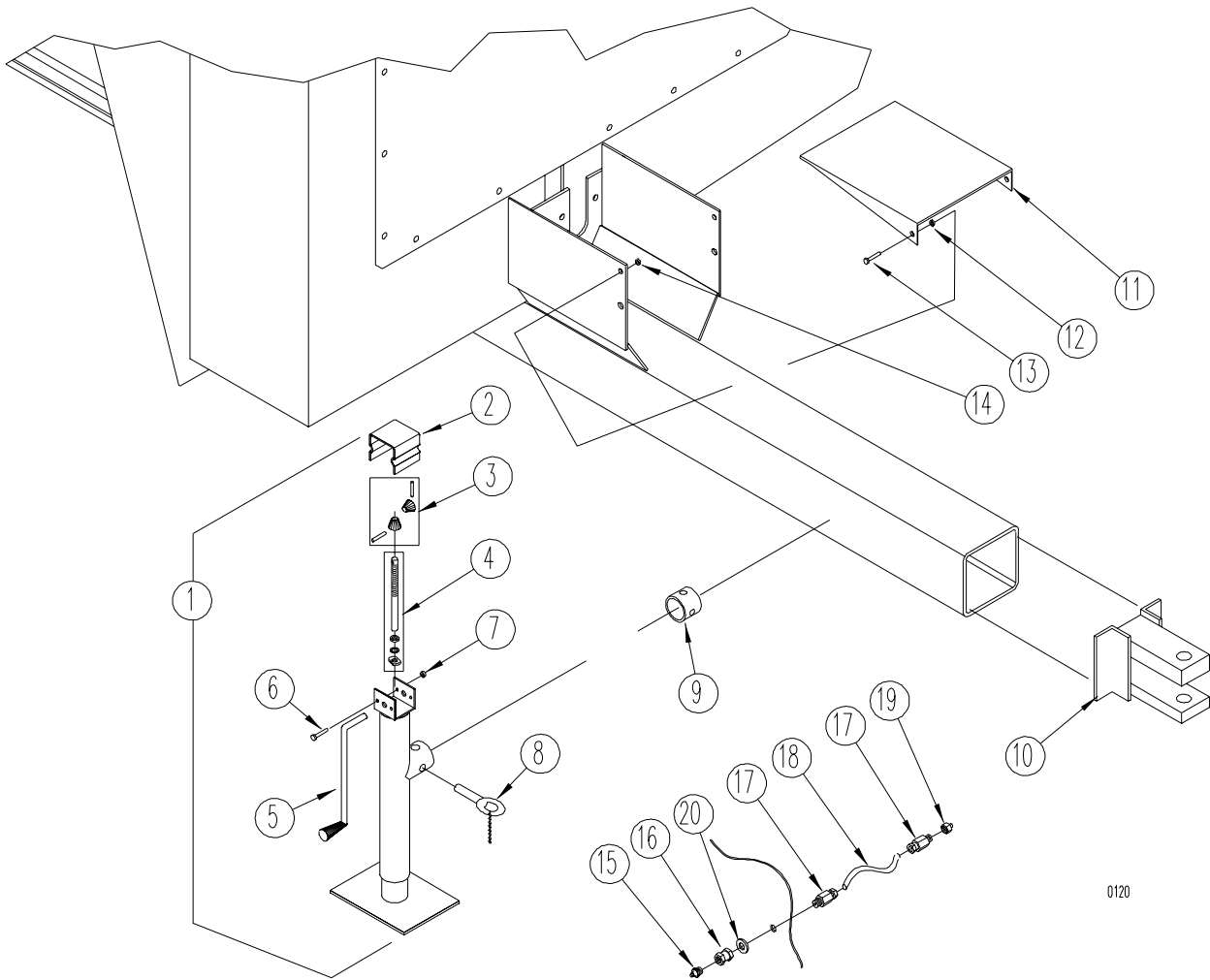

Fig. B

FRONT END PARTS



0120

FRONT END PARTS

REF	PART NO	QTY	DESCRIPTION
1	171-610	1	Jack, sidewind 7000 lb
2	171-814	1	Cover
3	171-614	1	Gear Kit (2 bevel gears, 2 pins)
4	171-611	2	Screw, nut, bearing & washer assy
5	171-612	1	Crank Assembly
6	170-509	2	Carriage bolt; 1/4" x 3"
7	170-125	2	Nut, 1/4"
8	171-613	1	Pull Pin
9	171-615	1	Mount Tube
10	101-598	1	Clevis Assy 8018 only (weld on)
	101-637	1	Clevis Assy 8024 only (weld on)
11	135-610	1	Shield; PTO Cover
12	171-393	2	Washer, Belleville 3/8"
13	170-262	2	5/16" x 3/4" Bolt
14	170-028	2	Nut, Flange Lock 5/16"

GREASE LINES

15	170-865	1*	Grease Zerk 1/8" NPT
16	172-024	1*	Coupling
17	172-822	2*	Compression Fitting
18	180-630**		Grease Line Tubing
		25"	Required for left front auger bearing
		19 "	Required for right front auger bearing
		12"	Required for front upper counter shaft bearing
		21"	Required for rear upper counter shaft bearing
		19"	Required for front lower counter shaft bearing
		9"	Required for rear lower counter shaft bearing
		37"	Required for inner input shaft bearing
		19"	Required for front hammer shaft bearing
		10" ^A	Required for left rear auger bearing
		10" ^A	Required for right rear auger bearing
19	172-823***	1*	Adapter Fitting
20	170-244	1*	Flat Washer 3/8"

A: used on S/N 8018-2944 and 8024-1915 and after.

* Quantity required to complete 1 grease line assy

** Sold by the linear foot.

*** Not required on all installations.

FRONT DRIVE PARTS

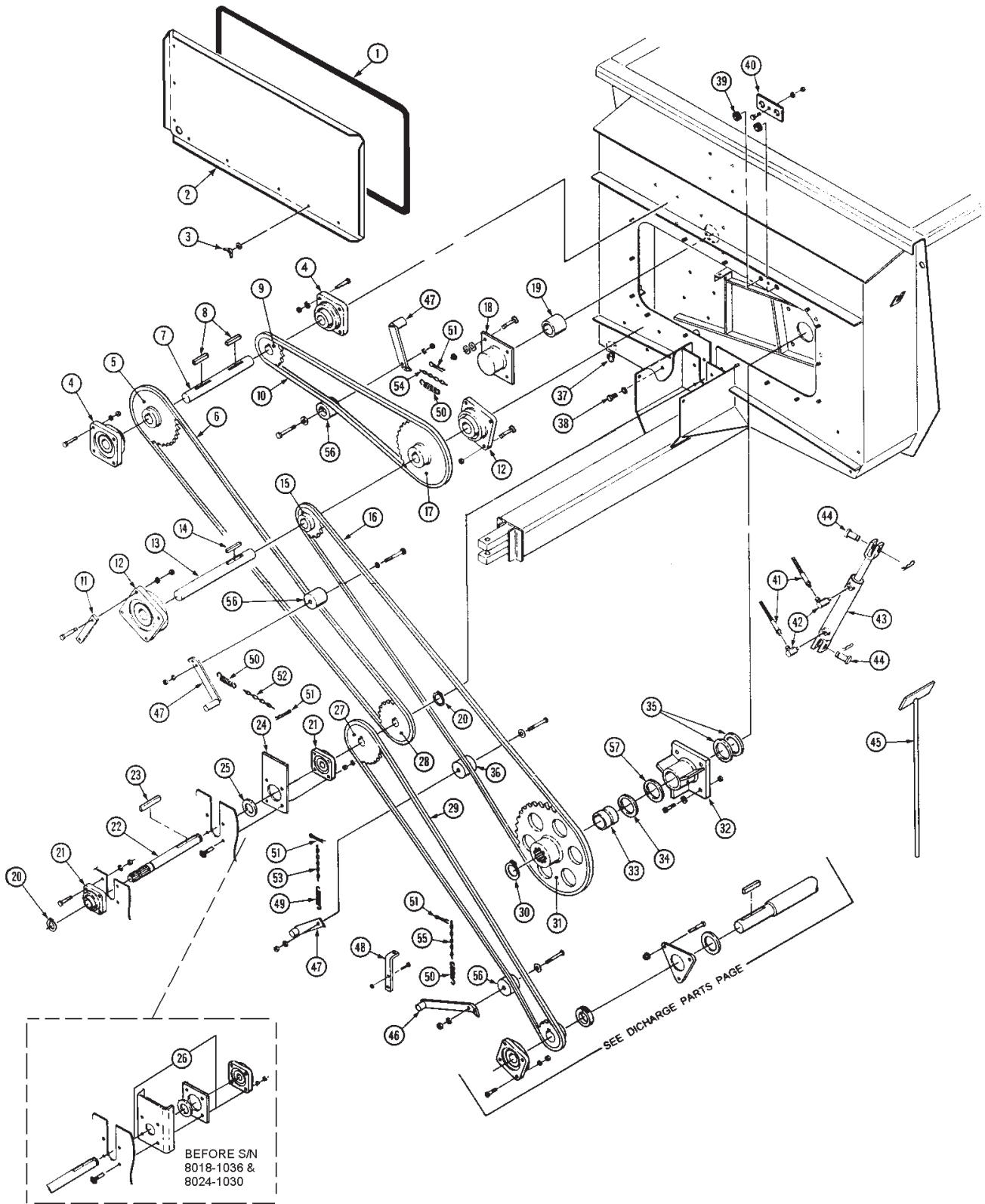

FRONT DRIVE PARTS

REF	PART NO	QTY	DESCRIPTION
1	171-935	10 ft.	Gasket; Foam Seal
2	135-538	1	Shield; Front Oil Enclosure
3	171-929	16	Wing Nut; 3/8" and 3/8" Flat Washer
4	170-008	2	Bearing, 2" Roller; Mtg Hrd: 5/8" x 1-3/4" Bolt, LW, Nut (4 ea)
5	133-476	1	Sprocket; 60-B-55 x 2" Bore, Inc. 170-249 set screw
6	172-828	1	Roller Chain; 60-1-130 P (540 RPM) (8018 only)
	172-827	1	Roller Chain; 60-1-121 P (1000 RPM)
7	134-842	1	Counter Shaft; 2" x 12 1/2"
8	170-835	2	Key; 1/2" Sq. x 1-1/2"
9	135-551	1	Sprocket; 80-B-15 x 2" Bore, Inc. 170151 set screw
10	172-831	1	Roller Chain; 80-1-86 P
11	135-540	1	Bearing Standoff Bar
12	170-053	2	Bearing, 2 1/2" Roller; Mtg Hrd: 5/8" x 2 1/2" Bolt (front brg.) 5/8" x 1-3/4" Bolt, (rear brg.) LW, Nut (4 ea)
13	133-530	1	Counter Shaft; 2-1/2" x 12 3/4"
14	171-769	1	Key; 5/8" Sq. x 4-3/8"
15	130-175	1	Sprocket; 120-B-12 x 2 1/2" Bore, Inc. 170-249 set screw
16	172-832	1	Roller Chain; 120-1-66 P
17	135-541	1	Sprocket; 80-B-42 x 2 1/2" Bore, Inc. 170-249 set screw
18	102-212	1	Bearing Assy 2"; Mtg Hrd: 5/8" x 1 1/4" Bolt (4 ea), FW (8 ea), LN (4ea)
19	135-614	1	Bushing, straight; 2" ID x 2 1/2" x 2"
20	170-499	2	Snap Ring; 1-3/8"
21	171-585	2	Bearing, 1 3/8" Roller; Mtg Hrd: 1/2" x 1 3/4" Bolt, LW, Nut (8ea)
22	134-670	1	Input Shaft; 1 3/8" x 13 1/2"
23	172-894	1	Key; 3/8" Sq. x 2 3/8"
24	136-974 ^B	1	Seal Plate
25	173-164 ^B	1	Seal, Lip
26			No Longer Available Replace With Items (24) 136-974 & (25) 173-164
27	134-461	1	Sprocket; 60-B-36 x 1 3/8" Bore (540 RPM) (8018 only)
	134-459	1	Sprocket; 60-B-20 x 1 3/8" Bore (1000 RPM)
28	135-539	1	Sprocket; 60-B-33 x 1 3/8" Bore (540 RPM) Inc. 170151 set screw (8018 only)
	130-128	1	Sprocket; 60-B-18 x 1 3/8" Bore (1000 RPM) Inc. 170151 set screw
29	172-830	1	Roller Chain; 60-H-112 P (540 RPM) (8018 only)
	172-829	1	Roller Chain; 60-H-1-104 P (1000 RPM)
30	171-607	1	Snap Ring; 3 1/2"
31	134-792	1	Sprocket; 120-B-48 x 3-1/2" Bore
32	102-215	1	Bearing Housing; Mtg Hrd: 5/8" x 1 1/4" Bolt, FW, Nut (4 ea)
33	135-613	1	Bushing, Straight; 4 1/4" x 3 1/2" x 4 1/2"
34	172-874	1	Quadring Seal
35	135-598	2	Thrust Washer

A: Before Serial Number: **8018**-118 But also including #64, 77, 78, 97: **8024**-74, a 134-155 tightener block was used on the 120 chain.

B: For serial numbers **8018**:1036 and before; **8024**:1030 and before replace with Items (24) 136-974 & (25) 173-164.

C: Cylinder manufacturers have changed: Use for serial number **8018**: 1361 and before; **8024**:729 and before.

FRONT DRIVE PARTS

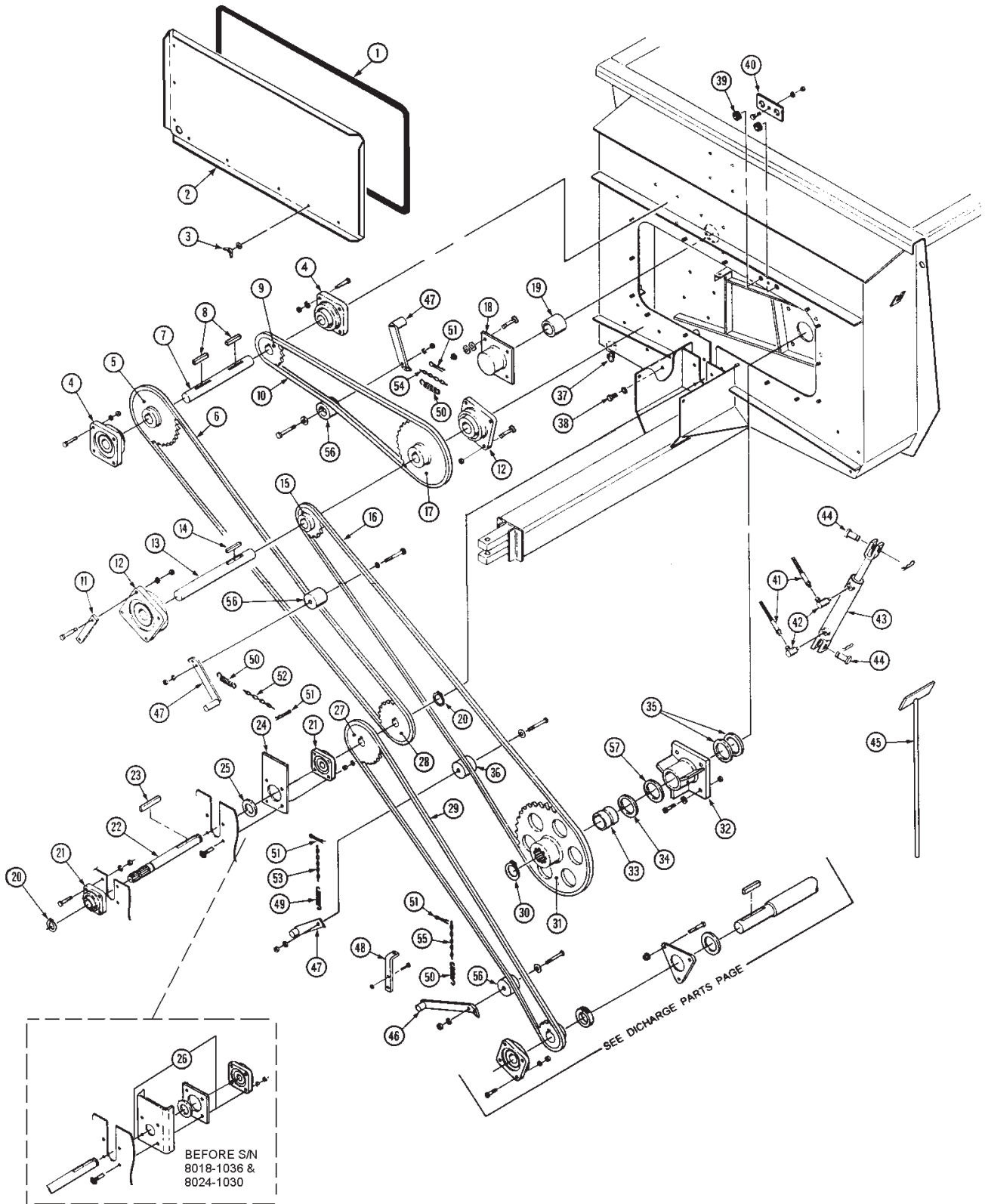

FRONT DRIVE PARTS

REF	PART NO	QTY	DESCRIPTION
36	134-086 ^A	1	Plastic Tightener Block; Mtg Hrd: 1/2" x 4" Bolt, FW, LW, Nut (1 ea)
37	171-919	1	Plug: 1 1/4" PVC
38	171-252	1	1/2" x 3/4" Bolt and 172-884 Washer, Nylon 1/2"
39	172-876	2	Rubber Grommet
40	135-607	1	Grommet Retainer; Mtg Hrd: 1/4" x 3/4" Bolt, LW, Nut (1 ea)
41	171-309	2	Hydraulic Hose; 1/4" x 132" OAL
42	171-030	2	Swivel Adapter; 3/8" x 90
43	173-271	1	Hydraulic Cylinder; 2 1/2" x 8", Order Seal Kit # (170-464) adjustable yoke
	170-232 ^C	1	Hydraulic Cylinder; 2 1/2" x 8", Order Seal Kit # (170-464) non-adjustable yoke
44	173-274	2	Clevis Pin; Includes retaining pin (173-274)
	170-073 ^C	2	Clevis Pin; Includes retaining pin (170-074)
45	101-636	1	Cleanout Tool
46	101-761	1	Tightener Arm
47	101-911	3	Tightener Arm
48	134-889	1	Retainer Arm; Mtg Hrd: 5/16" x 3/4" Bolt, FLN (2 ea)
49	172-751	1	Spring, 8 1/4 x 1 1/2"
50	172-005	3	Spring, 6" x 1"
51	170-800	4	Pin, clinch 3/16 x 1 1/2"
52	170-518	1	Machine Chain; #4 x 30 Links
53	171-045	1	Machine Chain; #4 x 22 Links
54	170-845	1	Machine Chain; #4 x 17 Links
55	170-845	1	Machine Chain; #4 x 17 Links
56	134-155	3	Plastic Tightener Block; Mtg Hrd; 1/2" x 2-3/4" Bolt, FW, LW, Nut (1 ea)
57	136-286	1	Nylon Thrust Washer 1/8" x 3 1/2" ID

A: Before Serial Number: **8018**-118 But also including #64, 77, 78, 97: **8024**-74, a 134-155 tightener block was used on the 120 chain.

B: For serial numbers **8018**:1036 and before; **8024**:1030 and before replace with Items (24) 136-974 & (25) 173-164.

C: Cylinder manufacturers have changed: Use for serial number **8018**:1361 and before; **8024**:729 and before.

DISCHARGE PARTS

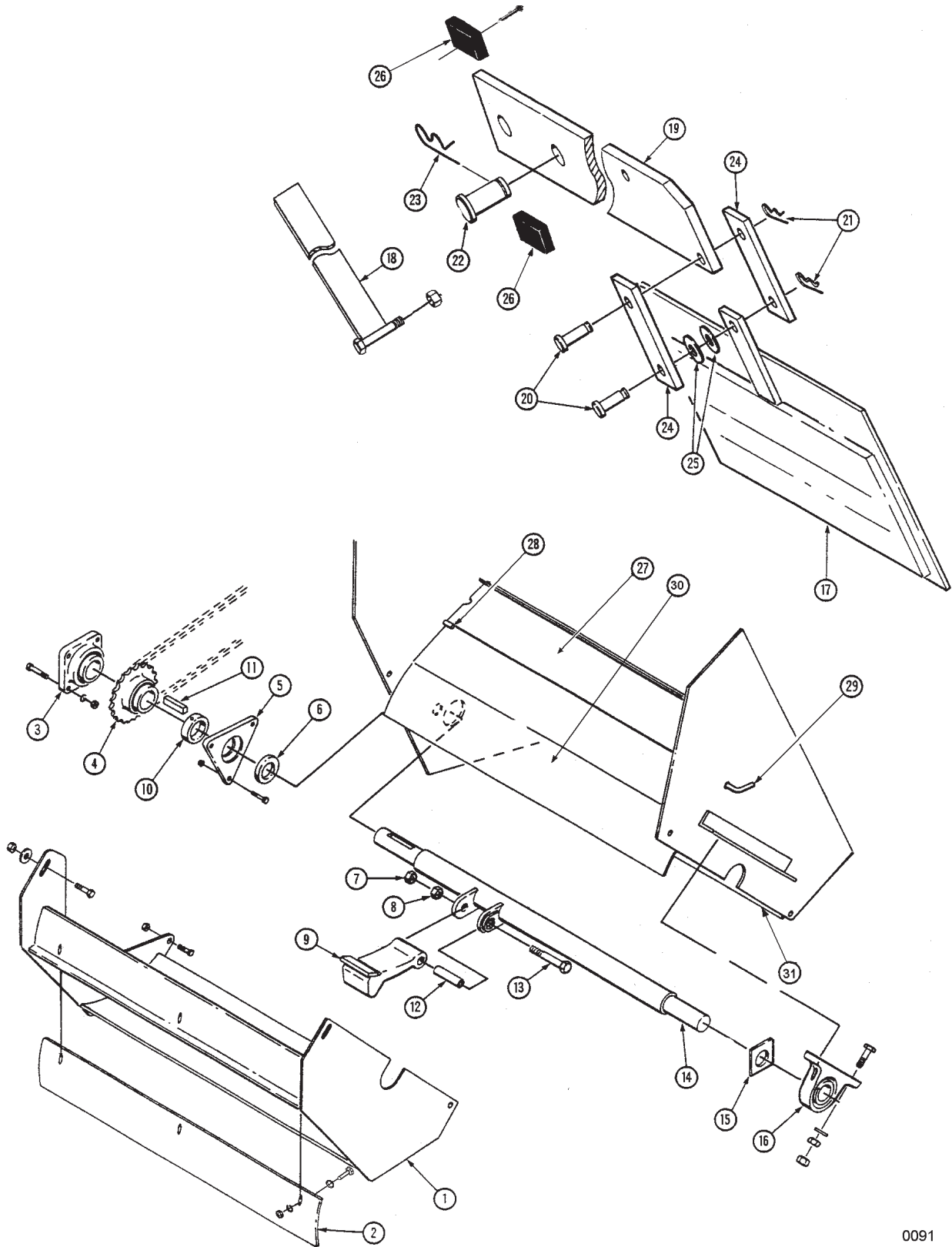

DISCHARGE PARTS

REF	PART NO	QTY	DESCRIPTION
1	102-059	1	Discharge Shroud Assy; Mtg Hrd 3/8" x 1" Bolt, & LN (4 ea) 1" Machine Washer (2 ea) (upper shroud mt. only)
2	134-666	1	Shroud Visor; Mtg Hrd 5/16" x 1" FW, LW & Nut
3	170-008	1	Bearing; 2" Flanged; Mtg Hrd 5/8" x 1-3/4" LW & Nut
4	134-460	1	Sprocket; 60-B-23, 2" Bore 1/2" KW, Inc. 170151 set screw
5	134-831	1	Seal Retainer Plate; Mtg Hrd 5/16" x 1" FLN
6	133-277	1	Washer, 2 1/2" ID Plastic
7	170-031	14	Lock Nut; 5/8" (Grade 5)
8	170-037	14	Jam Nut; 5/8" (Grade 5)
	172-866	1	Jam Lock Nut; 5/8" (Grade 5)(rear hammer only)
9	175-035	15	Hammer
10	172-772	1	Lock Collar 2"
11	170-835	1	Key; 1/2" x 1/2" x 1 1/2"
12	172-422	15	Bushing, Straight Nylon
13	172-421	14	Bolt; 5/8" x 5 1/2" Bolt (Grade 5)
	142-003	1	Bolt; 5/8" x 5 1/2" Bolt (Grade 5) (rear hammer only)
14	101-988	1	Hammer Shaft Assy
15	134-875	1	Plastic Shaft Seal
16	171-586	1	Pillow Block Bearing 2"; Mtg Hrd; 5/8" x 2 1/2" (172-381) B, FW, JN & LN (2 ea.)
17	101-986	1	Discharge Door Assy
18	102-208	1	Door Height Indicator Bar; Mtg Hrd; 1/2", LN
19	136-495	1	Pivot Linkage
	135-586 ^A	1	Pivot Linkage
20	171-696	2	Clevis Pin; 5/8" x 2"
21	170-236	2	Pin, Cotter 5/32" x 1 1/2"
22	170-073	2	Clevis Pin; 1" x 2 1/2"FW, JN & LN (2 ea.)
23	170-074	1	Pin, Hair 5/32" dia x 3 1/8"lg
24	135-608	2	Door Linkage
25	170-066	A/R	Flat Washer; 5/8"
26	172-875	1	Foam Seal; 7/8" x 2" x 3"; Mtg Hrd 170-056 1/4" x 2 cotter pin (1EA)
27	134-899	1	Cleanout Door (weld on)
28	133-637	1	Pin, Door Hinge (weld on)
29	133-636	1	Handle, Cleanout Door (weld on)
30	134-846	1	Top door frame (weld on)
31	134-649	1	Bottom plate (weld on)

A: Door pivot bar has changed. Parts are not interchangeable with current production parts. Units built before 8018-1362, and 8024-730 must use 135-586 pivot linkage.

RUNNING GEAR PARTS

8018 Only S/N 8018- 1857 AND AFTER

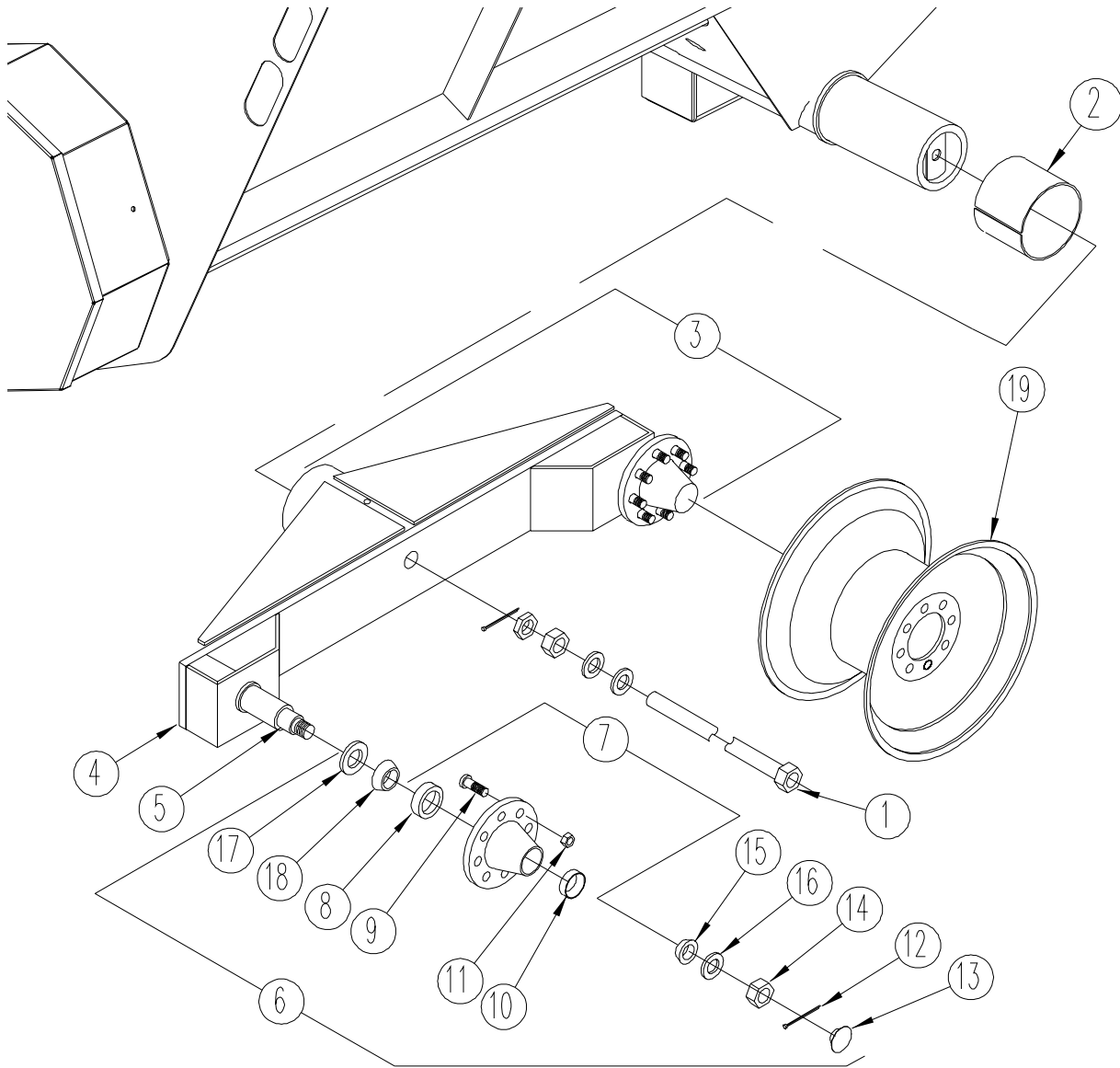

RUNNING GEAR PARTS***8018 Only*** *S/N 8018- 1857 AND AFTER*

REF	PART NO	QTY	DESCRIPTION
1	101-613	1	Tie Rod Assembly Mtg Hrd: 3/4" Nut, Jam Nut, (170-236) Cotter Pin (1 ea) & FW (2)
2	133-565	2	Bushing; Bogie Pivot
3	102-518	1	RH Bogie Assembly
4	102-516	1	RH Bogie Weldment
	170-865	1	Grease Zerk 1/8" NPT
5	136-989	2	Spindle; 2 1/2" x 14" Long
6	174-587	2	8-Bolt Hub Assembly
7	174-582	1	8-Bolt Hub; includes (1ea) 170-865 Grease Zerk 1/8" NPT
8	174-583	1	Inside Bearing Race; Timken JLM506810
9	174-586	8	Stud; 5/8" x 2 1/2"
10	171-825	1	Outside Bearing Race; Timken LM501310
11	171-827	8	Wheel Nut 5/8"
12	170-056	2	Cotter Pin; 1/4" x 2"
13	171-830	2	Dust Cap
14	171-833	2	Castle Nut; 1" NF
15	171-829	2	Outside Bearing Cone; Timken LM501349
16	171-832	2	Washer, Spindle 3"
17	174-585	2	Grease Seal; C/R 25091
18	174-584	2	Inside Bearing Cone; Timken JLM506849
3	102-517	1	LH Bogie Assembly
4	102-515	1	LH Bogie Weldment
	170-865	1	Grease Zerk 1/8" NPT
5	136-989	2	Spindle; 2 1/2" x 14" Long
6	174-587	2	8-Bolt Hub Assembly
7	174-582	1	8-Bolt Hub; includes (1ea) 170-865 Grease Zerk 1/8" NPT
8	174-583	1	Inside Bearing Race; Timken JLM506810
9	174-586	8	Stud; 5/8" x 2 1/2"
10	171-825	1	Outside Bearing Race; Timken LM501310
11	171-827	8	Wheel Nut 5/8"
12	170-056	2	Cotter Pin; 1/4" x 2"
13	171-830	2	Dust Cap
14	171-833	2	Castle Nut; 1" NF
15	171-829	2	Outside Bearing Cone; Timken LM501349
16	171-832	2	Washer, Spindle 3"
17	174-585	2	Grease Seal; C/R 25091
18	174-584	2	Inside Bearing Cone; Timken JLM506849
19	174-581	4	Wheel; 16.1" x 14", 8-Hole 3/8" positive offset
	172-285	4	Wheel; 22 1/2" x 8 1/4", 8-Hole 3/8" positive offset
	172-229	4	Wheel; 22 1/2" x 11 1/4", 8-Hole 3/8" positive offset

8024 Only

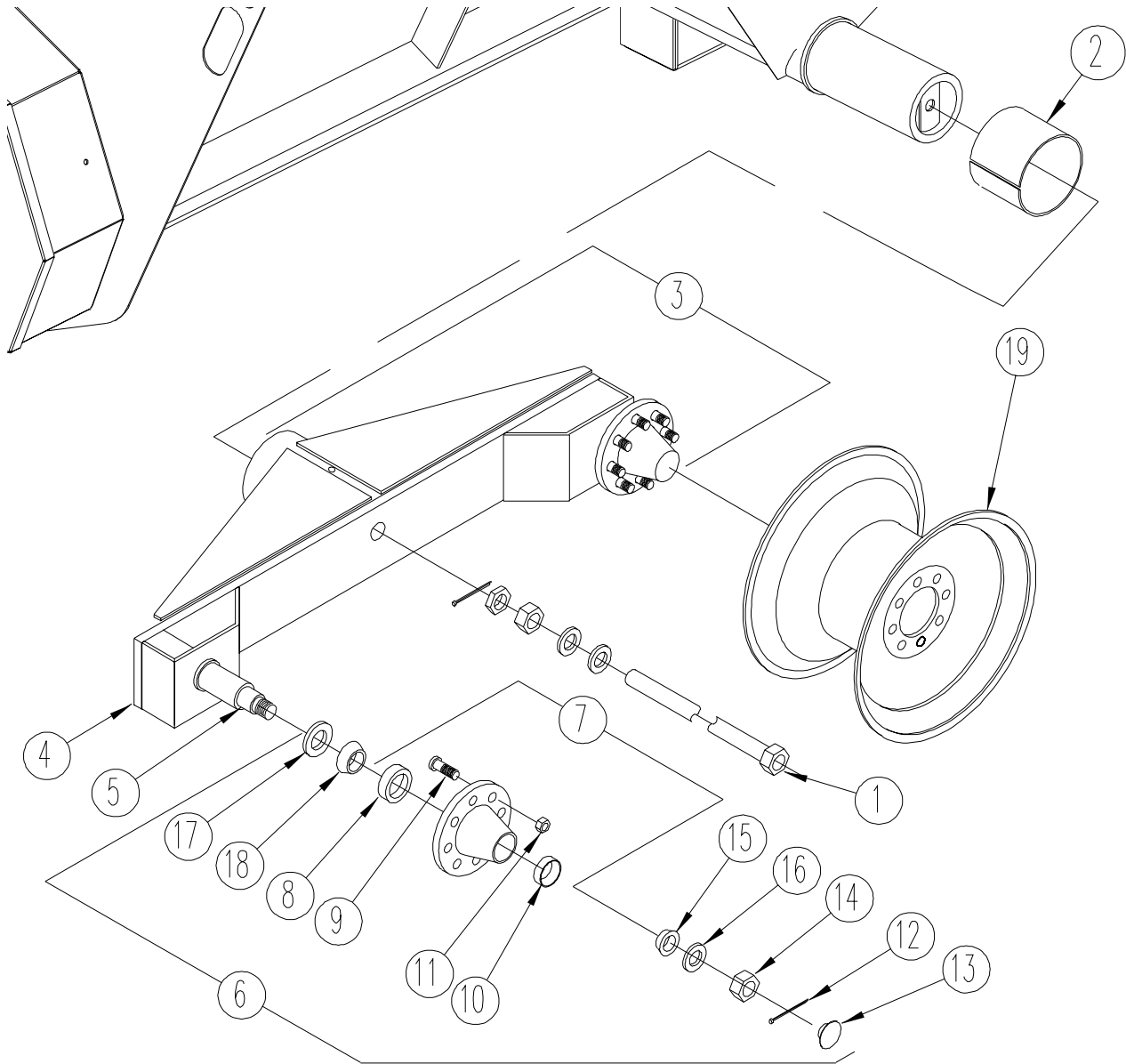

RUNNING GEAR PARTS**8024 Only**

REF	PART NO	QTY	DESCRIPTION
1	101-613	1	Tie Rod Assembly Mtg Hrd: 3/4" N, Jam Nut, (170-236) Cotter Pin (1 ea) & FW (2)
2	133-565	2	Bushing; Bogie Pivot
3	101-646	1	RH Bogie Assembly
4	101-644	1	RH Bogie Weldment
	170-865	1	Grease Zerk 1/8" NPT
5	171-808	2	Spindle; 3" x 16" Long
6	171-815	2	8-Bolt Hub Assembly
7	171-823	1	8-Bolt Hub; includes (1ea) 170-865 Grease Zerk 1/8" NPT
8	171-824	1	Inside Bearing Race; Timken 382A
9	171-826	8	Stud; 5/8"
10	171-825	1	Outside Bearing Race; Timken LM501310
11	171-827	8	Wheel Nut
12	170-056	2	Cotter Pin; 1/4" x 2"
13	171-830	2	Dust Cap
14	171-833	2	Castle Nut; 1" NF
15	171-829	2	Outside Bearing Cone; Timken LM501349
16	171-832	2	Washer, Spindle 3"
17	171-831	2	Grease Seal; C/R 29968
18	171-828	2	Inside Bearing Cone; Timken 387AS
3	101-645	1	LH Bogie Assembly
4	101-643	1	LH Bogie Weldment
	170-865	1	Grease Zerk 1/8" NPT
5	171-808	2	Spindle; 3" x 16" Long
6	171-815	2	8-Bolt Hub Assembly
7	171-823	1	8-Bolt Hub; includes (1ea) 170-865 Grease Zerk 1/8" NPT
8	171-824	1	Inside Bearing Race; Timken 382A
9	171-826	8	Stud; 5/8"
10	171-825	1	Outside Bearing Race; Timken LM501310
11	171-827	8	Wheel Nut
12	170-056	2	Cotter Pin; 1/4" x 2"
13	171-830	2	Dust Cap
14	171-833	2	Castle Nut; 1" NF
15	171-829	2	Outside Bearing Cone; Timken LM501349
16	171-832	2	Washer, Spindle 3"
17	171-831	2	Grease Seal; C/R 29968
18	171-828	2	Inside Bearing Cone; Timken 387AS
19	171-809	4	Wheel; 16" x 16.1", 8-Hole 3/8" pos offset
	172-229	4	Wheel; 22.5" x 11.25", 8-Hole 3/8" pos offset

8018 Only *S/N 8018- 1856 AND BEFORE*

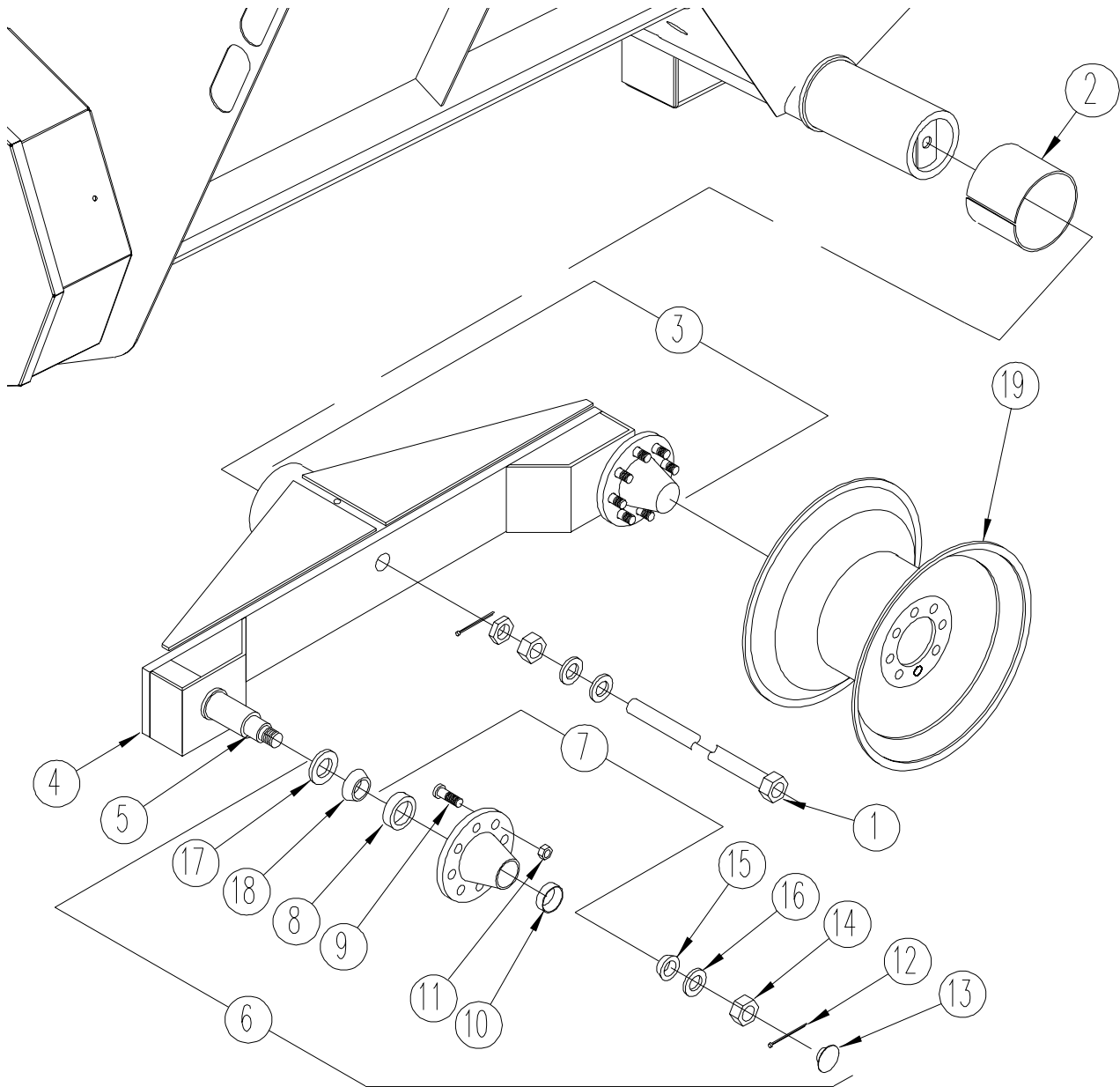

RUNNING GEAR PARTS**8018 Only S/N 8018- 1856 AND BEFORE**

REF	PART NO	QTY	DESCRIPTION
1	101-613	1	Tie Rod Assembly Mtg Hrd: 3/4" N, Jam Nut, (170-236) Cotter Pin (1 ea) & FW (2)
2	133-565	2	Bushing; Bogie Pivot
3	101-616	1	RH Bogie Assembly
4	101-614	1	RH Bogie Weldment
	170-865	1	Grease Zerk 1/8" NPT
5	134-464	2	Spindle; 2 1/2" x 14 1/8" Long
6	170-755	2	8-Bolt Hub Assembly
7	170-705	1	8-Bolt Hub
8	170-553	1	Inside Bearing Race Timken 3720
9	171-826	8	Stud; 5/8"
10	170-546	1	Outside Bearing Race Timken 14276
11	171-827	8	Wheel Nut 5/8"
12	170-236	2	Cotter Pin; 5/32" x 1 1/2"
13	170-550	2	Dust Cap
14	170-132	2	Castle Nut; 7/8" NF
15	170-545	2	Outside Bearing Cone Timken 14137A
16	170-131	2	Flat Washer; 7/8" Heavy
17	170-556	2	Grease Seal National 415082
18	170-554	2	Inside Bearing Cone Timken 3780
3	101-617	1	LH Bogie Assembly
4	101-615	1	LH Bogie Weldment
	170-865	1	Grease Zerk 1/8" NPT
5	134-464	2	Spindle; 2 1/2" x 14 1/8" Long
6	170-755	2	8-Bolt Hub Assembly
7	170-705	1	8-Bolt Hub
8	170-553	1	Inside Bearing Race Timken 3720
9	171-826	8	Stud; 5/8"
10	170-546	1	Outside Bearing Race Timken 14276
11	171-827	8	Wheel Nut
12	170-236	2	Cotter Pin; 5/32" x 1 1/2"
13	170-550	2	Dust Cap
14	170-132	2	Castle Nut; 7/8" NF
15	170-545	2	Outside Bearing Cone Timken 14137A
16	170-131	2	Flat Washer; 7/8" Heavy
17	170-556	2	Grease Seal
18	170-554	2	Inside Bearing Cone Timken 3780
19	170-112	4	Wheel; 20" x 8", 8-Hole 1 1/2" negative offset
	174-559	4	Wheel; 16.1" x 14", 8-Hole 1 1/2" negative offset
	172-284	4	Wheel; 22 1/2" x 8 1/4", 8-Hole 1 1/2" negative offset

REAR DRIVE PARTS

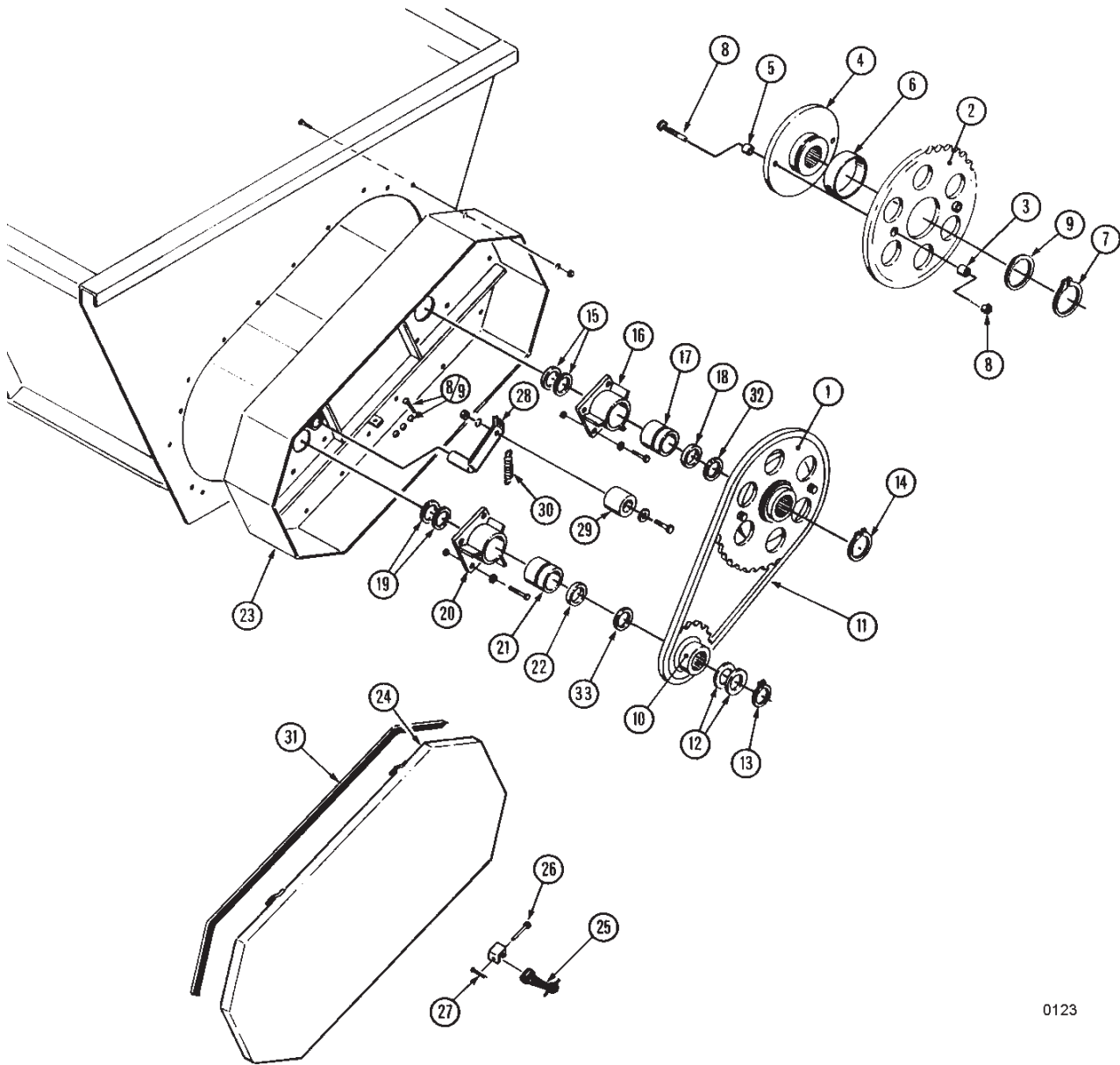

0123

REAR DRIVE PARTS

REF	PART NO	QTY	DESCRIPTION
1	102-207	1	Shear Sprocket and Hub Assembly
2	102-226	1	Shear Sprocket Assembly
3	134-893	2	Bushing (weld on)
4	102-225	1	Shear Hub Assembly
5	134-893	2	Bushing (weld on)
6	134-481	1	Bronze Bushing (press fit into hub)
7	171-989	1	Snap Ring; 4" External
8	170-168	1	Shear Bolt; 1/2" x 3" Grade 5; 170-042: Lock Nut, 1/2" Grade 5
9	134-892	1	Retainer Plate
10	135-550	1	Sprocket 100B-24 2 1/2" Splined Bore
11	170-952	1	Roller Chain 100-1-78P
12	172-046	A/R	Spacer Washer 2 1/2" I.D. 14 Gage
	171-968	A/R	Spacer Washer 2 1/2" I.D. 10 Gage
13	170-152	1	Snap Ring; 2 1/2" External
14	171-934	1	Snap Ring; 3" External
15	135-597	2	Thrust Washer, plastic; 3" I.D.
16	102-214	1	Bearing Assembly; 3" Mtg Hrd: 5/8" x 1 1/4" Bolt, LN (4 ea), FW (8 ea)
17	135-612	1	Bushing, Straight 3" I.D. NYLON
18	172-873	1	Quadring Seal; 2 7/8" I.D.
19	135-596	2	Thrust Washer; 2 1/2" I.D.
20	102-213	1	Bearing Assembly; 2-1/2" Mtg Hrd: Mtg Hrd: 5/8" x 1 1/4" B, LN (4 ea), Fw (8 ea)
21	135-611	1	Bushing, Straight; 2-1/2" I.D. NYLON
22	172-872	1	Quadring Seal; 2-3/8" I.D.
23	102-205	1	Rear End Enclosure Assembly; Mtg Hrd; 5/16" x 3/4" Bolt, LW, Nut (22 ea)
24	102-224	1	Rear Shield Assembly
25	170-950	1	Rubber Latch; mounting bracket 170-939
26	171-137	1	Pin; 1/4" x 1-1/2"
27	170-364	1	Cotter Pin
28	101-911	1	Tightener Arm
29	134-155	1	Tightener Block; Mtg Hrd; 1/2" x 2-3/4" Bolt, LW, Nut (1 ea)
30	172-751	1	Spring 8 1/2" LG x 1 1/2" O.D.
31	171-935*	5'	Foam Gasket" (4' 7" long)
32	136-285	1	Nylon Thrust Washer, 3"
33	136-284	1	Nylon Thrust Washer, 2 1/2"

* Sold by the linear foot.

Grease line is listed in "Front End Parts" section.

AUGER & SPLASH GUARD PARTS

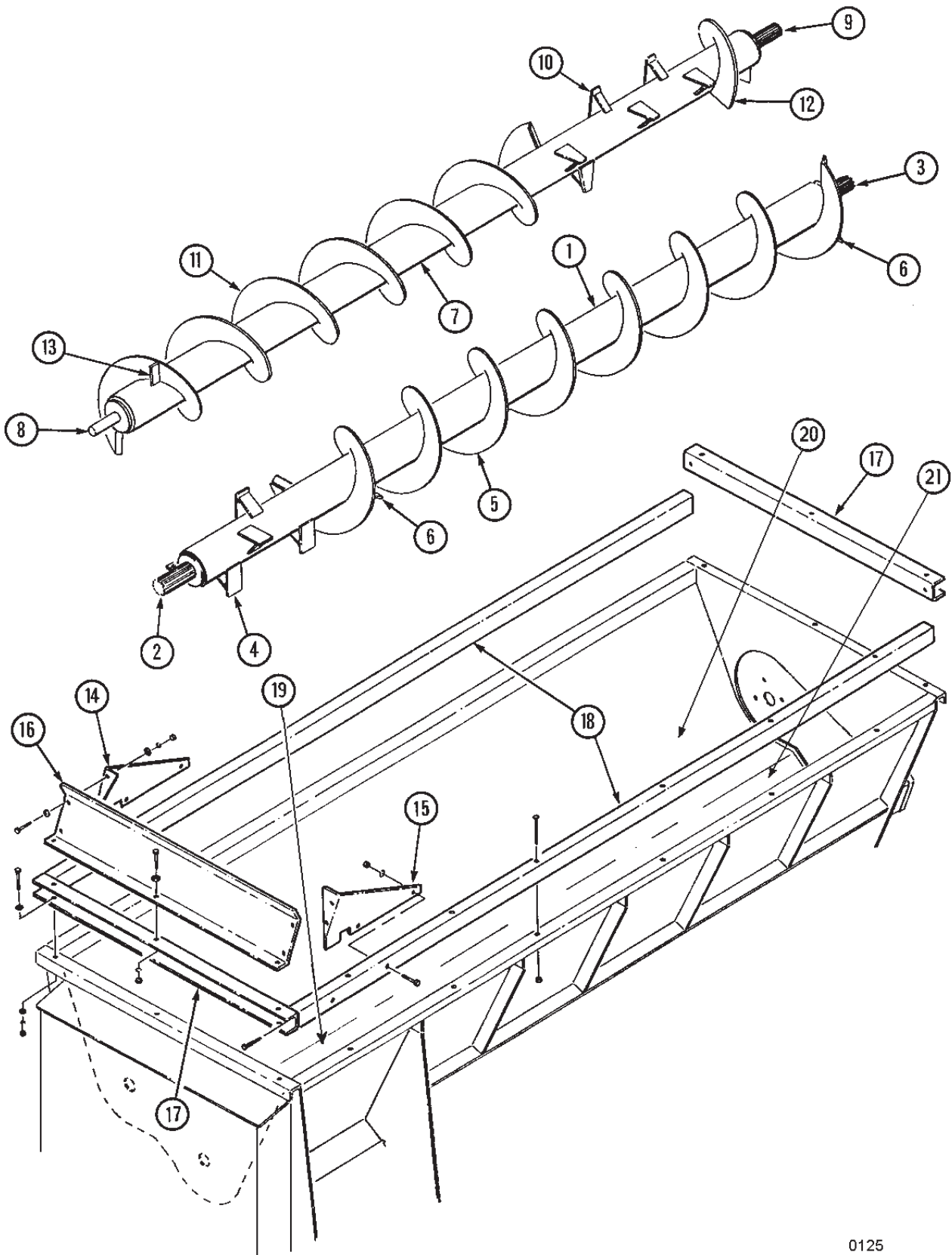

AUGER & SPLASH GUARD PARTS

REF	PART NO	QTY	DESCRIPTION
1	102-241	1	Left Auger Assembly
2	102-240	1	Front Plug Assembly; 3 1/2"
	102-220 ^A	1	Front Plug Assembly; 3 1/2"
3	102-238	1	Rear Plug Assembly; 2 1/2"
	102-222 ^A	1	Rear Plug Assembly; 2 1/2"
4	102-216	6	Paddle Assembly
5	135-595	2	Flighting; 3/8" x 8-5/8" x 20" x 86" Helicoid L.H. with super edge
	136-257	A/R	Repair Flighting section; 3/8" x 8-5/8" x 20" x 16 1/2" Helicoid L.H. with super edge
6	135-555	6	Flighting Brace
7	102-521	1	Right Auger assembly
8	102-520	1	Front Plug Assembly, 2"
	102-237 ^B	1	Front Plug Assembly; 2"
	102-223 ^A	1	Front Plug Assembly; 2"
9	102-519	1	Rear Plug Assembly, 3"
	102-239 ^B	1	Rear Plug Assembly; 3"
	102-221 ^A	1	Rear Plug Assembly; 3"
10	103-517	8	Paddle Assembly; 5 9/16" Dia Tube
	102-217 ^C	8	Paddle Assembly; 8 5/8" Dia Tube
11	136-981	2	Flighting; 3/8" x 5 9/16" x 20" x 66" R.H. with super edge
	135-594 ^C	2	Flighting; 3/8" x 8 5/8" x 20" x 66" R.H.
12	136-980	1	Flighting; 3/8" x 5 9/16" x 20" x 16 1/2" L.H. with super edge
	136-257 ^C	1	Flighting; 3/8" x 8 5/8" x 20" x 16 1/2" L.H.
13	136-979	8	Flighting Brace; 5 9/16" Dia
	135-555 ^C	8	Flighting Brace; 8 5/8" Dia
14	133-556	1	Splash Guard (RH FT & LH RR) Mtg Hrd; 3/8" x 3-1/2" C Bolt, Nut (2 ea)
15	133-557	1	Splash Guard (LH FT & RH RR) Mtg Hrd; 3/8" x 3-1/2" C Bolt, Nut (2 ea)
16	135-590	1	Splash Guard End 8024 (FT & RR) Mtg Hrd; 5/16" x 1"B, FW, LW, Nut (7 ea)
	135-588	1	Splash Guard End 8018 (FT & RR) Mtg Hrd; 5/16" x 1"B, FW, LW, Nut (7 ea)
17	135-587	2	End Panel Extension 8018 Mtg Hrd; 5/16" x 1" B, FW, LW Nut (3 ea) & 3/8" x 2 1/2' Lag Bolt, FW (2 ea)
	135-589	2	End Panel Extension 8024 Mtg Hrd; 5/16" x 1" Bolt, FW, LW Nut (3 ea) & 3/8" x 2 1/2' Lag Bolt, FW (2 ea)
18	134-890	2	Wood Side Rail: 4" x 3" x 191 1/2" Mtg Hrd; 3/8" x 4 1/2" C Bolt, Nut (6 ea)
19	102-235	A/R	Shear Shelf
20	136-234	A/R	48" Right Hopper Replacement section
21	136-235	A/R	48" Left Hopper Replacement section

A: Auger designs have changed allowing the shaft assemblies to fit inside of the auger tube. Use before serial number **8018**: 261 but also including #'s: 271 thru 281, 283, 285, 286, 294,298. Use before serial number **8024**:130 but also including #'s133, 135, 136, 139, 140

B: Use for serial number **8018**: 262 through 1808 but NOT including #'s: 271 thru 281, 283, 285, 286, 294,298. Use for serial number **8024**:131 through 999 but NOT including #'s133, 135, 136, 139, 140.

C: Use for serial numbers before **8018**:1809 and **8024**:1000.

LID PARTS

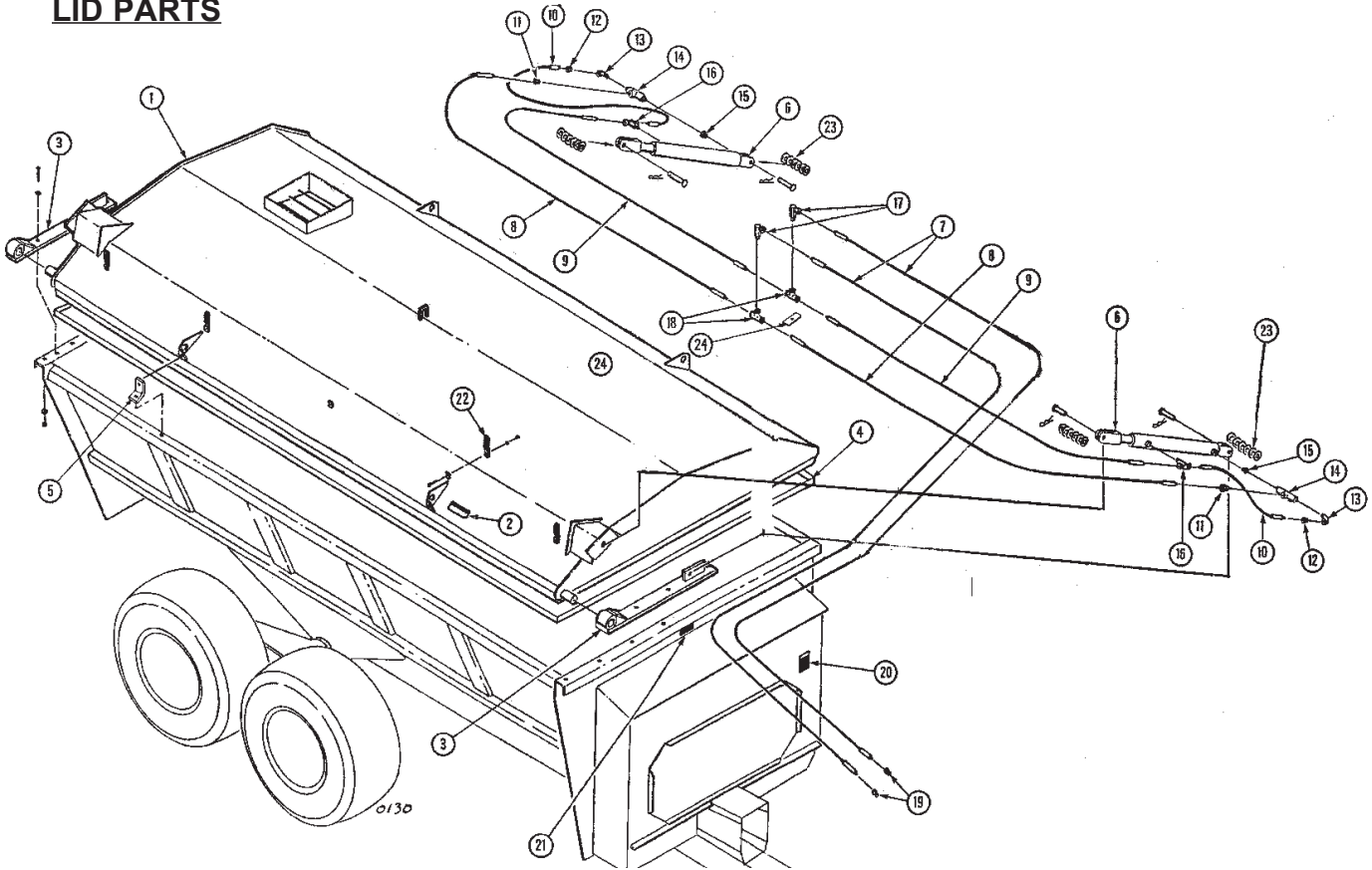

REF	PART NO	QTY	DESCRIPTION
1	102-234	1	Top Lid Assembly
2	172-821	1	Decal; Caution - Do Not Lift Here
3	102-073	2	Cylinder Mount - Pivot Mtg Hrd: 1/2" x 1 1/2" Bolt, LN (4 ea), FW (8 ea)
4	173-114*	45'	Seal, Push On
5	136-213	4	Hold Down Bracket; Mtg Hrd: 1/2" x 1 1/4"B (1 ea); 1/2" x 1 3/4"B (1 ea); Fw,Lw, N (2 ea)
6	170-161	2	Hydraulic Cylinder 2" x 18" (Includes clevis pin & hairpin clip)
7	171-460	2	Hydraulic Hose; 1/4" x 294" OAL
8	170-466	2	Hydraulic Hose; 1/4" x 138" OAL
9	171-998	2	Hydraulic Hose; 1/4" x 118" OAL
10	172-794	2	Hydraulic Hose; 1/4" x 20" OAL
11	170-233	2	Swivel Adapter; 3/8"
12	171-251	2	Swivel Adapter; 1/4" To 3/8" Straight
13	172-809	2	Fitting; 90 Deg. Street Elbow, 1/4"
14	172-806	2	Pilot Operated Check Valve
15	172-808	2	Flow Restrictor, 3/8"
16	172-807	2	Swivel Tee Adapter, 3/8"
17	171-030	2	Swivel Adapter; 3/8" x 90 Deg.
18	171-442	2	Tee Adapter; 3/8"
19	170-235	2	Reducer Fitting; 1/2" To 3/8"
20	172-599	1	Decal; Danger - Overhead Wires
21	172-787	2	Decal; Warning - Crushing Under Top..(Front & Rear)
22	171-782	6	Hose Clamp; Mtg Hrd: 5/16" x 1" Bolt, LW, FLN
23	170-122	A/R	Washer, flat 1" (Approximately 24 Req'd)
24	140-468	2	Strip, Hose Mount 3" x 1" x 1/8" Mtg Hrd: 5/16" x 1 1/2" Bolt, FLN

* Sold by the linear foot.

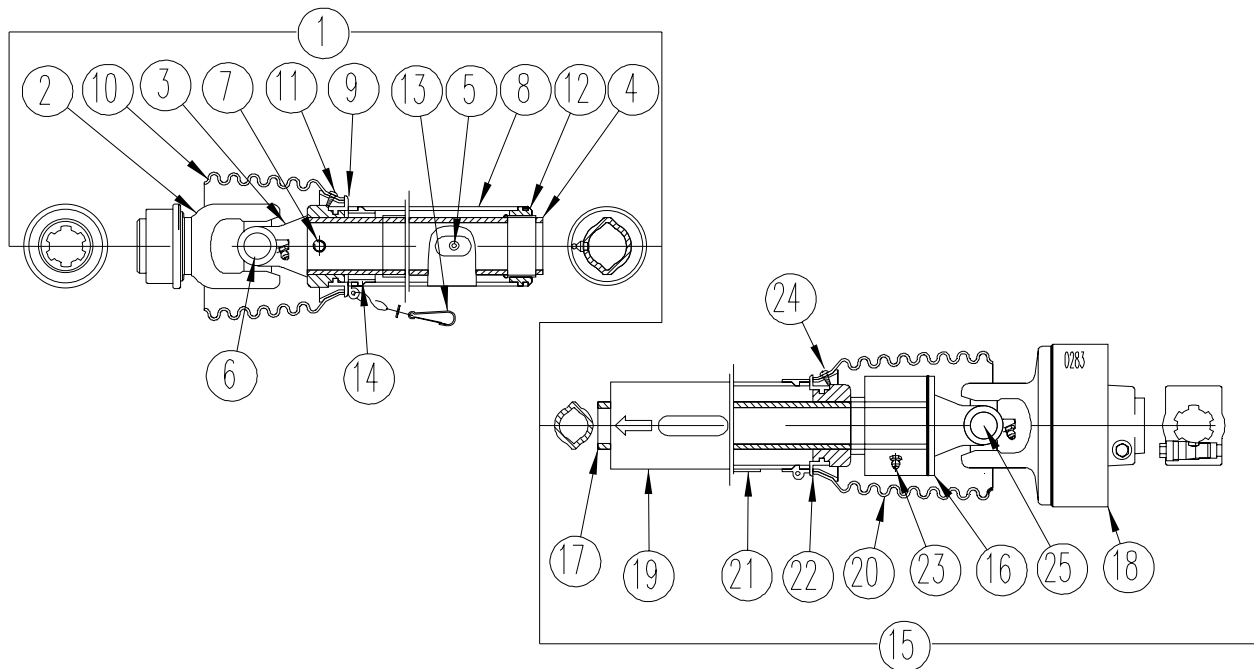
PTO DRIVELINE & TORQUE DISCONNECT *non-cv***(540 RPM - 6 SPLINE / 1-3/8" YOKE)****(PTO parts are used on units, Serial Number (8018-1148 540 RPM) and after.)**

REF	PART NUMBER	QTY	DESCRIPTION
	174-877	1	PTO Assy, W2400, 540 RPM
1	174-973	1	Front Half Assy, Outer Profile W/ Guard 1 3/8 - 6 Spline
2	172-034	1	Yoke 1 3/8 - 6 Spline
	172-028	1	Lock Collar Repair Kit
3	172-033	1	Inboard Yoke
4	174-961	1	Outer Profile & Sleeve
5	172-209	1	Zerk
6	171-980	1	Cross and Bearing Kit
7	171-983	1	Spring Pin, 10 x 80
8	174-965	1	Inner Shield
9	171-979	1	Bearing Ring
10	172-030	1	Shield Cone 6 Rib
11	172-210	1	Screw
12	172-207	1	Support Bearing
13	172-040	1	Safety Chain
14	171-799	1	Decal
15	174-974	1	Rear Half Assy, Half Cut-Out Clutch W/ Guard
16	174-962	1	Overrunning Clutch & Inner Profile Assy
17	174-968	1	Inner Profile
18	174-956	1	Cut-Out Clutch
	174-966	1	Lock Bolt, Torqued to 75 Ft. Lbs. (17mm 6pt socket required)
19	174-964	1	Outer Shield
20	174-959	1	Shield Cone 8 Rib
21	171-550	1	Decal
22	171-979	1	Bearing Ring
23	172-208	1	Zerk
24	172-210	1	Screw
25	171-980	1	Cross and Bearing Kit

PTO DRIVELINE & TORQUE DISCONNECT *non-cv*

(1000 RPM - 21 SPLINE / 1-3/8" YOKE)

PTO parts are used on units, Serial Number (8018-1114 1000 RPM), (8024-580 1000 RPM) and after.)

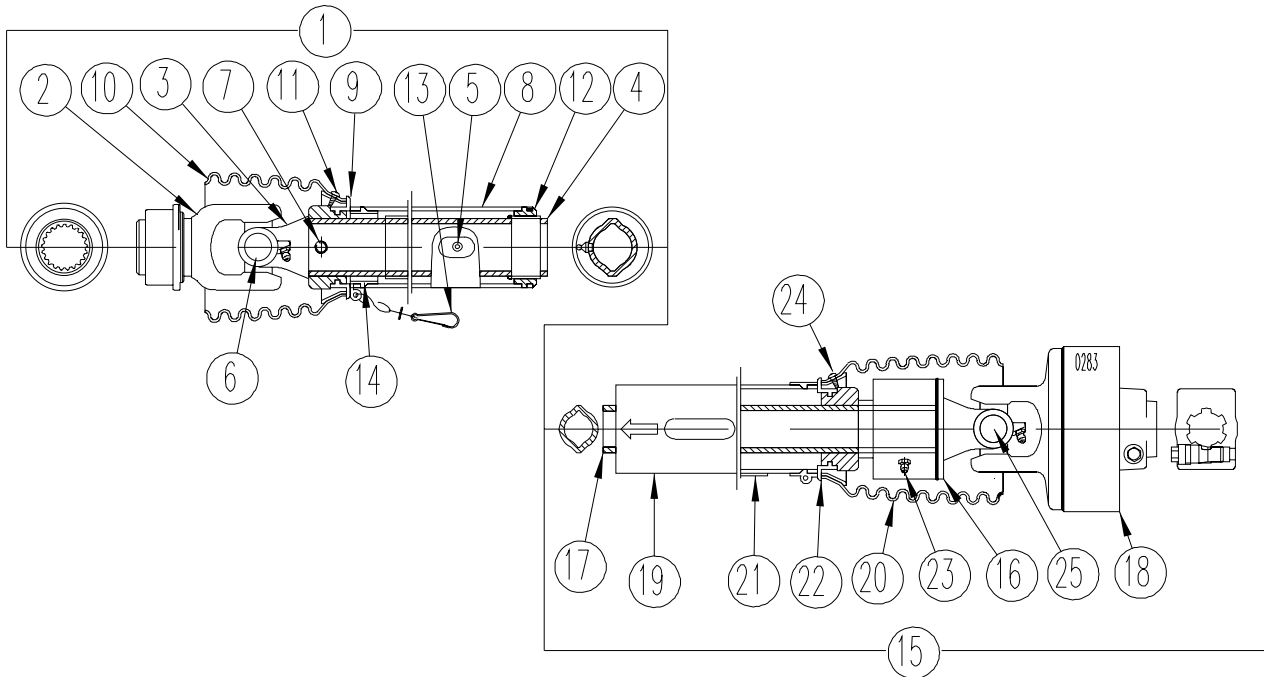

REF	PART NUMBER	QTY	DESCRIPTION
	174-878	1	PTO Assy, W2400, 1000 RPM
1	174-975	1	Front Half Assy, Outer Profile W/ Guard 1 3/8 - 21 Spline
2	173-757	1	Yoke 1 3/8 - 21 Spline
	172-028	1	Lock Collar Repair Kit
3	172-033	1	Inboard Yoke
4	174-961	1	Outer Profile & Sleeve
5	172-209	1	Zerk
6	171-980	1	Cross and Bearing Kit
7	171-983	1	Spring Pin, 10 x 80
8	174-965	1	Inner Shield
9	171-979	1	Bearing Ring
10	172-030	1	Shield Cone 6 Rib
11	172-210	1	Screw
12	172-207	1	Support Bearing
13	172-040	1	Safety Chain
14	171-799	1	Decal
15	174-976	1	Rear Half Assy, Half Cut-Out Clutch W/ Guard
16	174-962	1	Overrunning Clutch & Inner Profile Assy
17	174-968	1	Inner Profile
18	174-963	1	Cut-Out Clutch
	174-966	1	Lock Bolt, Torqued to 75 Ft. Lbs. (17mm 6pt socket required)
19	174-964	1	Outer Shield
20	174-959	1	Shield Cone 8 Rib
21	171-550	1	Decal
22	171-979	1	Bearing Ring
23	172-208	1	Zerk
24	172-210	1	Screw
25	171-980	1	Cross and Bearing Kit

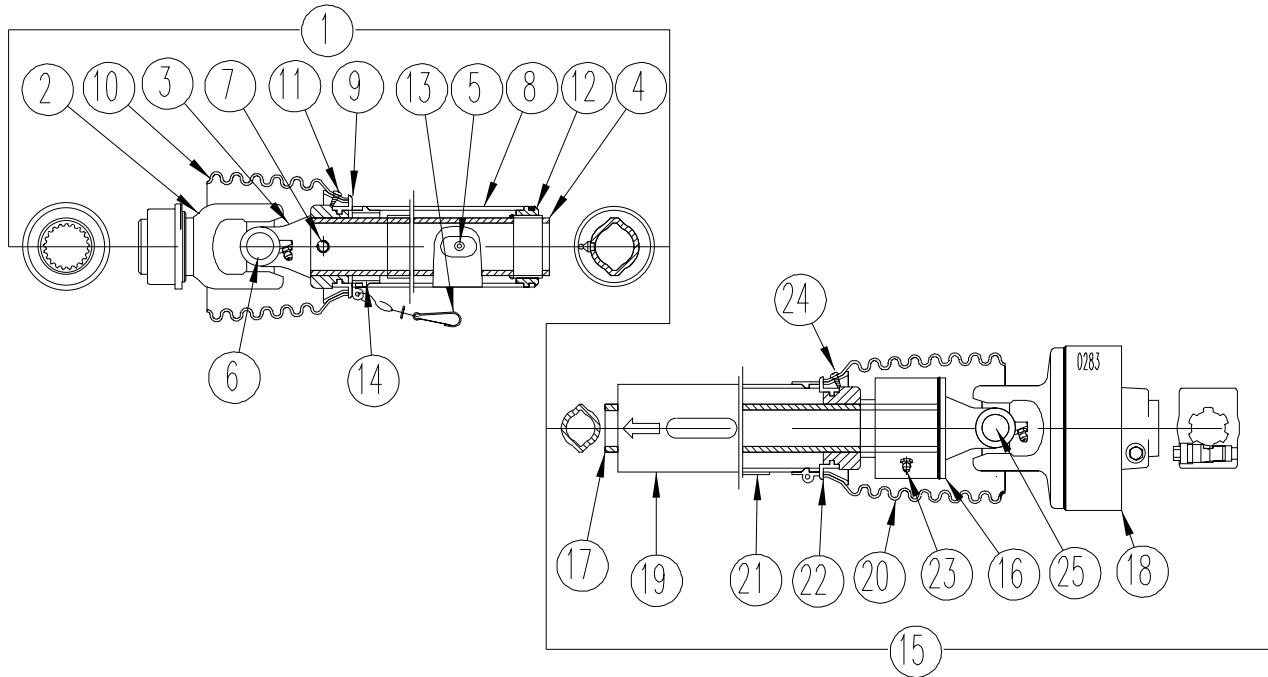
PTO DRIVELINE & TORQUE DISCONNECT *non-cv***(1000 RPM - 20 SPLINE / 1-3/4" YOKE)****PTO parts are used on units, Serial Number (8018-1114 1000 RPM), (8024-580 1000 RPM) and after.)**

REF	PART NUMBER	QTY	DESCRIPTION
	174-879	1	PTO, Assy, W2400, 1000 RPM
1	174-977	1	Front Half Assy, Outer Profile W/ Guard 1 3/4 - 20 Spline
2	173-791	1	Yoke 1 3/4 - 20 Spline
	174-967	1	Lock Collar Repair Kit
3	172-033	1	Inboard Yoke
4	174-961	1	Outer Profile & Sleeve
5	172-209	1	Zerk
6	171-980	1	Cross and Bearing Kit
7	171-983	1	Spring Pin, 10 x 80
8	174-965	1	Inner Shield
9	171-979	1	Bearing Ring
10	172-030	1	Shield Cone 6 Rib
11	172-210	1	Screw
12	172-207	1	Support Bearing
13	172-040	1	Safety Chain
14	171-799	1	Decal
15	174-976	1	Rear Half Assy, Half Cut-Out Clutch W/ Guard
16	174-962	1	Overrunning Clutch & Inner Profile Assy.
17	174-968	1	Inner Profile
18	174-963	1	Cut-Out Clutch
	174-966	1	Lock Bolt, Torqued to 75 Ft. Lbs. (17mm 6pt socket required)
19	174-964	1	Outer Shield
20	174-959	1	Shield Cone 8 Rib
21	171-550	1	Decal
22	171-979	1	Bearing Ring
23	172-208	1	Zerk
24	172-210	1	Screw
25	171-980	1	Cross and Bearing Kit

PTO DRIVELINE & FRICTION CLUTCH -CV
(540 RPM - 6 SPLINE / 1 3/8" YOKE)

(PTO parts are used on units, Serial Number(8018-1148 540 RPM) and after.)

REF	PART NO	QTY	DESCRIPTION
1	173-195	1	80° CV-PTO Assembly (Less clutch pack)
2	172-842	1	Outer Joint and Shaft Half with Guard
3	172-991	1	Slide Lock Yoke Assembly (1 3/8")
4	171-544	1	Slide Lock Repair Kit
5	172-852	2	Cross and Bearing Kit
6	172-303	1	Center Housing
7	172-846	1	Yoke and Shaft Assembly
8	172-848	1	Outer Guard
9	170-220	1	Nylon Repair Kit
10	172-304	1	Bell Housing with Nylon Centralizer
11	171-550	1	Safety Decal
12	173-200	1	Inner Joint and Tube Half with Guard
13	172-847	1	Inner Guard
14	171-799	1	Safety Decal
15	170-220	1	Nylon Repair Kit
16	170-776	1	Cross and Bearing Kit
17	173-203	1	Clutch Hub
18	171-544	1	Slide Lock Repair Kit
19	172-845	1	Yoke Tube and Slip Sleeve
20	174-732	1	Friction Clutch Assembly; 18,000
21	173-204	1	Pressure Plate
22	174-733	1	Spring - (color white)
23	173-205	1	Compression Plate
24	172-860	2	Friction Disk
25	170-369	6	5/16" x 2 1/2" Bolt (grade 5)
26	170-119	6	5/16" Nut (grade 5)
27	173-202	1	Clutch Housing' Mtg Hrd: 5/16" x 1" bolt (grade 5)
28	173-206	1	Separator Plate

8018/8024TR 005816-R091399

PTO DRIVELINE & FRICTION CLUTCH -CV
(1000 RPM - 20 SPLINE / 1-3/4" YOKE)

PTO parts are used on units, Serial Number (8018-1114 1000 RPM), (8024-580 1000 RPM) and after.)

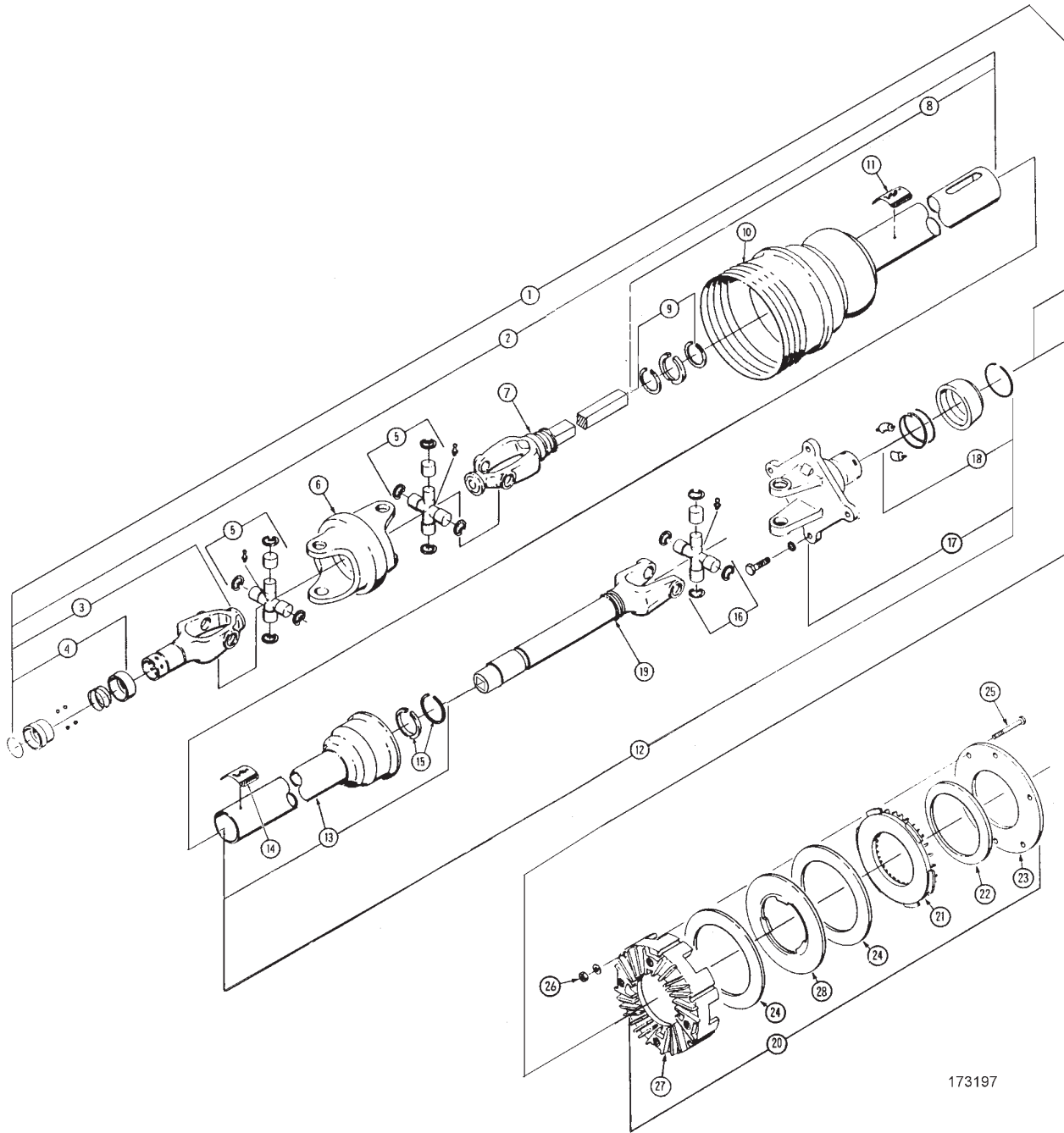

173197

PTO DRIVELINE & FRICTION CLUTCH -CV
(1000 RPM - 20 SPLINE / 1-3/4" YOKE)

PTO parts are used on units, Serial Number (8018-1114 1000 RPM), (8024-580 1000 RPM) and after.)

REF	PART NO	QTY	DESCRIPTION
1	173-197	1	80° CV-PTO Assembly (Less clutch pack)
2	172-841	1	Outer Joint and Shaft Half with Guard
3	172-851	1	Slide Lock Yoke Assembly (1-3/4")
4	172-496	1	Slide Lock Repair Kit
5	172-852	2	Cross and Bearing Kit
6	172-303	1	Center Housing
7	172-915	1	Yoke and Shaft Assembly
8	172-916	1	Outer Guard
9	170-220	1	Nylon Repair Kit
10	172-304	1	Bell Housing with Nylon Centralizer
11	171-550	1	Safety Decal
12	173-201	1	Inner Joint and Tube Half with Guard
13	172-994	1	Inner Guard
14	171-799	1	Safety Decal
15	170-220	1	Nylon Repair Kit
16	170-776	1	Cross and Bearing Kit
17	173-203	1	Clutch Hub
18	171-544	1	Slide Lock Repair Kit
19	172-993	1	Yoke Tube and Slip Sleeve
20	173-198	1	Friction Clutch Assembly; 12,000
21	173-204	1	Pressure Plate
22	173-207	1	Spring - (color green)
23	173-205	1	Compression Plate
24	172-860	2	Friction Disk
25	170-369	6	5/16" x 2-1/2" Bolt (grade 5)
26	170-119	6	5/16 Nut (grade 5)
27	173-202	1	Clutch Housing; Mtg Hrd: 5/16" x 1" bolt (grade 5)
28	173-206	1	Separator Plate

8018/8024TR 005816-R091399

PTO DRIVELINE & FRICTION CLUTCH -CV
(1000 RPM - 21 SPLINE / 1-3/8" YOKE)

parts are used on units, Serial Number (8018-1114 1000 RPM), (8024-580 1000 RPM) and after.)

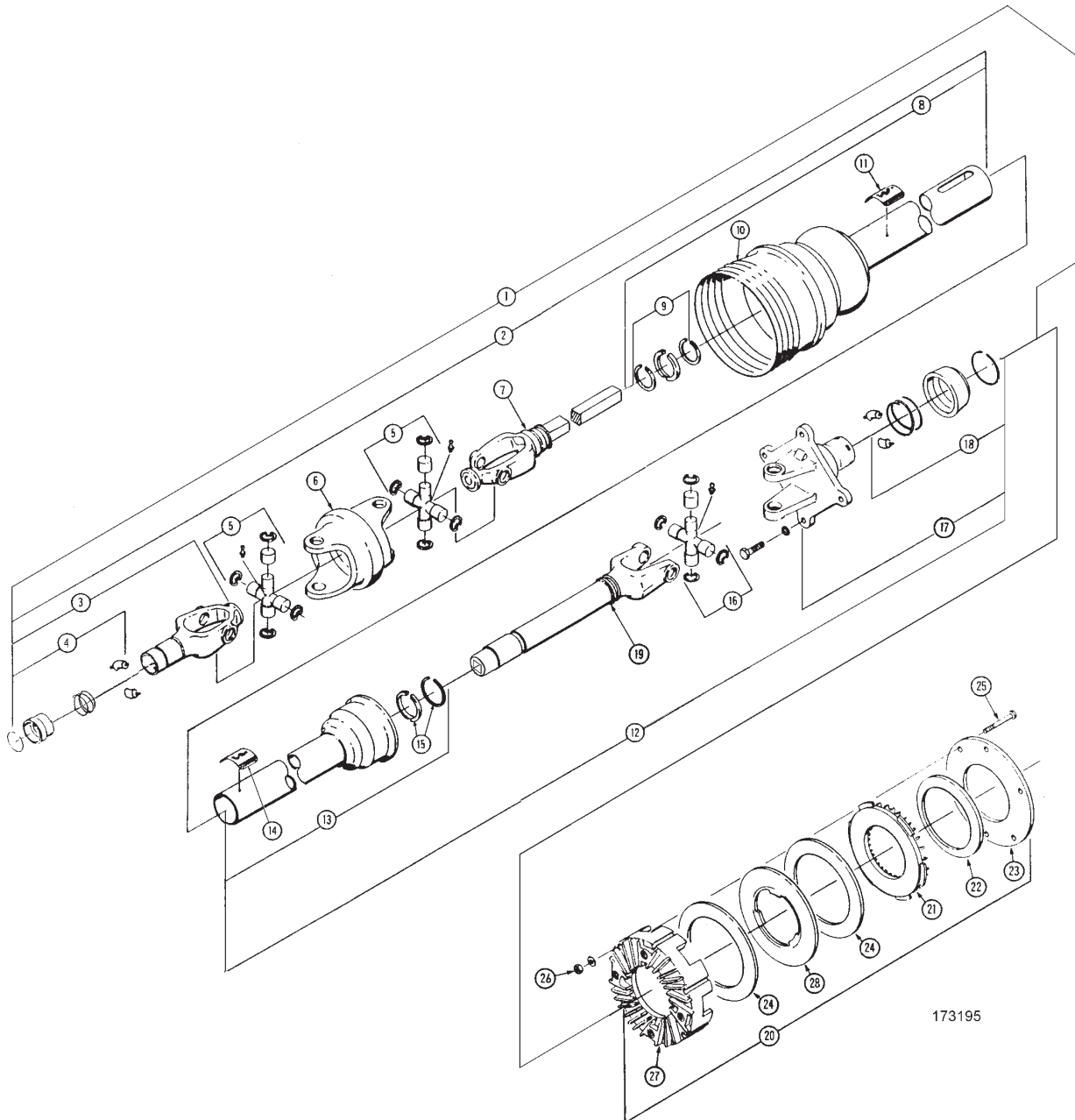

173195

PTO DRIVELINE & FRICTION CLUTCH -CV
(1000 RPM - 21 SPLINE / 1-3/8" YOKE)

parts are used on units, Serial Number (8018-1114 1000 RPM), (8024-580 1000 RPM) and after.)

REF	PART NO	QTY	DESCRIPTION
1	173-196	1	80° CV-PTO Assembly (Less clutch pack)
2	172-843	1	Outer Joint and Shaft Half with Guard
3	172-992	1	Slide Lock Yoke Assembly (1-3/8")
4	171-544	1	Slide Lock Repair Kit
5	172-852	2	Cross and Bearing Kit
6	172-303	1	Center Housing
7	172-846	1	Yoke and Shaft Assembly
8	172-848	1	Outer Guard
9	170-220	1	Nylon Repair Kit
10	172-304	1	Bell Housing with Nylon Centralizer
11	171-550	1	Safety Decal (Included with #11 - outer guard)
12	173-200	1	Inner Joint and Tube Half with Guard
13	172-847	1	Inner Guard (Includes #14 - 171-799 Danger decal)
14	171-799	1	Safety Decal (Included with #13 - 172-847 inner guard)
15	170-220	1	Nylon Repair Kit
16	170-776	1	Cross and Bearing Kit
17	173-203	1	Clutch Hub
18	171-544	1	Slide Lock Repair Kit
19	172-845	1	Yoke Tube and Slip Sleeve
20	173-198	1	Friction Clutch Assembly; 12,000
21	173-204	1	Pressure Plate
22	173-207	1	Spring - (color green)
23	173-205	1	Compression Plate
24	172-860	2	Friction Disk
25	170-369	6	5/16" x 2-1/2" Bolt (grade 5)
26	170-119	6	5/16" Nut (grade 5)
27	173-202	1	Clutch Housing; Mtg Hrd: 5/16" x 1" bolt (grade 5)
28	173-206	1	Separator Plate

8018/8024TR 005816-R091399

PTO DRIVELINE & FRICTION CLUTCH -CV

(540 RPM - 6 SPLINE) Weasler Constant Velocity PTO (1-3/8" YOKE)

PTO parts are used on units before serial number (8018-1148 540 RPM).

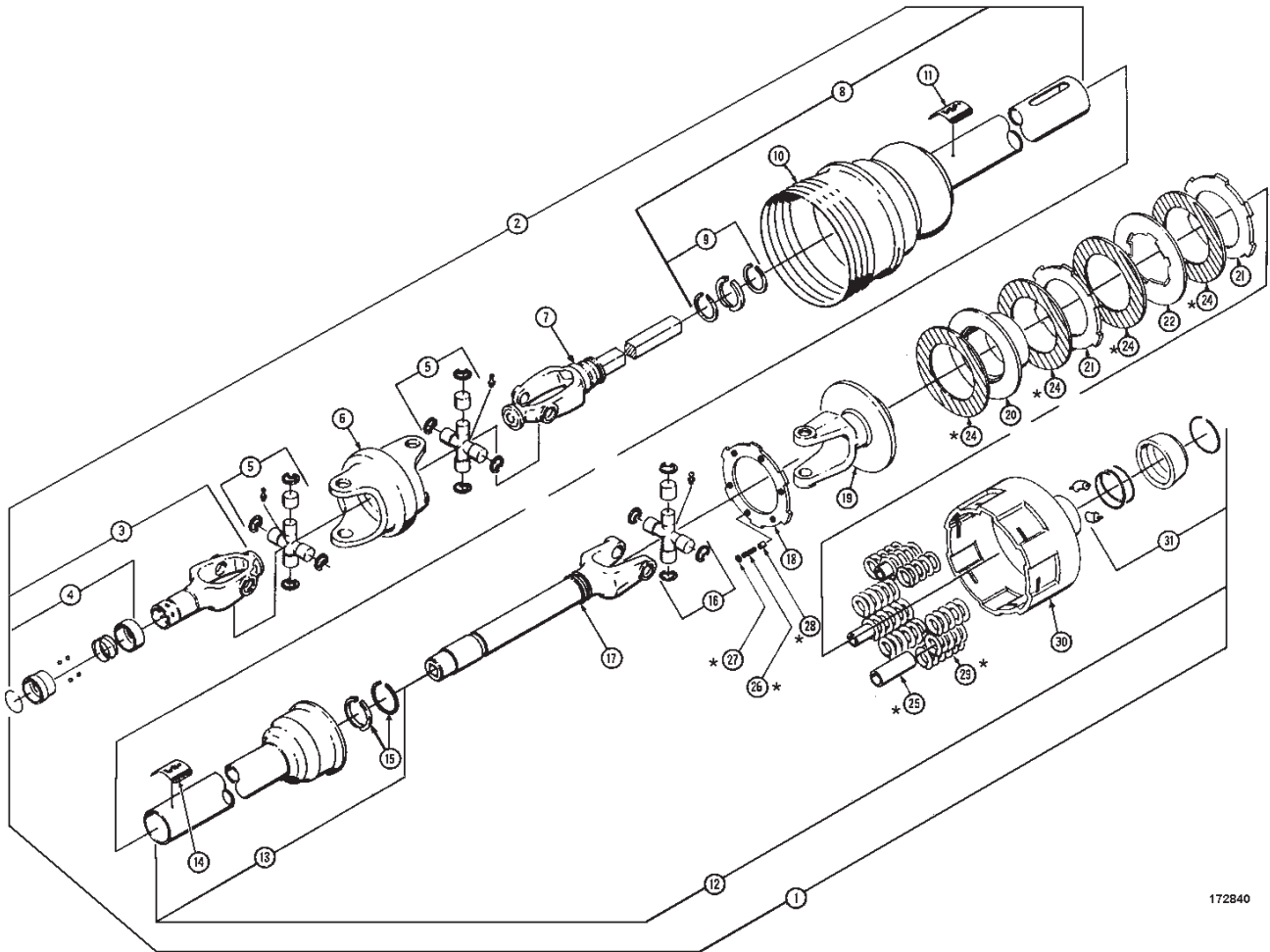

172840

PTO DRIVELINE & FRICTION CLUTCH -CV**(540 RPM - 6 SPLINE) Weasler Constant Velocity PTO (1-3/8" YOKE)*****PTO parts are used on units before serial number (8018-1148 540 RPM).***

REF	PART NO	QTY	DESCRIPTION
1	172-839	1	80° CV- PTO Assembly <i>(includes clutch pack)</i>
2	172-842	1	Outer Joint and Shaft Half with Guard
3	172-991	1	Spring Lock Yoke Assembly (1-3/8")
4	171-544	1	Slide Lock Repair Kit
5	172-852	2	Cross and Bearing Kit
6	172-303	1	Center Housing
7	172-846	1	Yoke and Shaft Assembly
8	172-848	1	Outer Guard
9	170-220	1	Nylon Repair Kit
10	172-304	1	Bell Extension with Nylon Centralizer
11	171-550	1	Safety Decal
12	172-844	1	Inner Joint and Shaft Half with Guard <i>(includes clutch pack)</i>
13	172-847	1	Inner Guard
14	171-799	1	Safety Decal
15	170-220	1	Nylon Repair Kit
16	170-776	1	Cross and Bearing Kit
17	172-845	1	Yoke Tube and Slip Sleeve
18	172-855	1	Lock Ring
19	172-853	1	Yoke and Plate
	173-159	1	bushing (not shown)
20	172-854	1	Inner Drive Hub
21	172-856	2	Plate - Outer Engaged
22	172-857	1	Plate - Inner Engaged
*	172-858	1	Friction Disk Repair Kit <i>(Weasler # 19-44425)</i>
24	172-860*	4	Friction Disk
25	172-885*	3	Spacer Bushing; Spring Stop
26	172-917*	6	Set Screw "5/16" NC x 1-1/2" SOC. HD.
27	170-119*	6	Nut; 5/16" NC Hex
28	172-918*	6	Spacer
29	172-861*	12	Spring
30	172-867	1	Housing Assembly
31	171-544	1	Slide Lock Repair Kit

* Friction disk repair kit contains all items noted with an *.

8018/8024TR 005816-R091399

PTO DRIVELINE & FRICTION CLUTCH -CV

(1000 RPM - 20 SPLINE) Weasler Constant Velocity PTO (1-3/4" YOKE)

PTO parts are used on units before serial number (8018-1114 1000 RPM), (8024-580 1000 RPM).

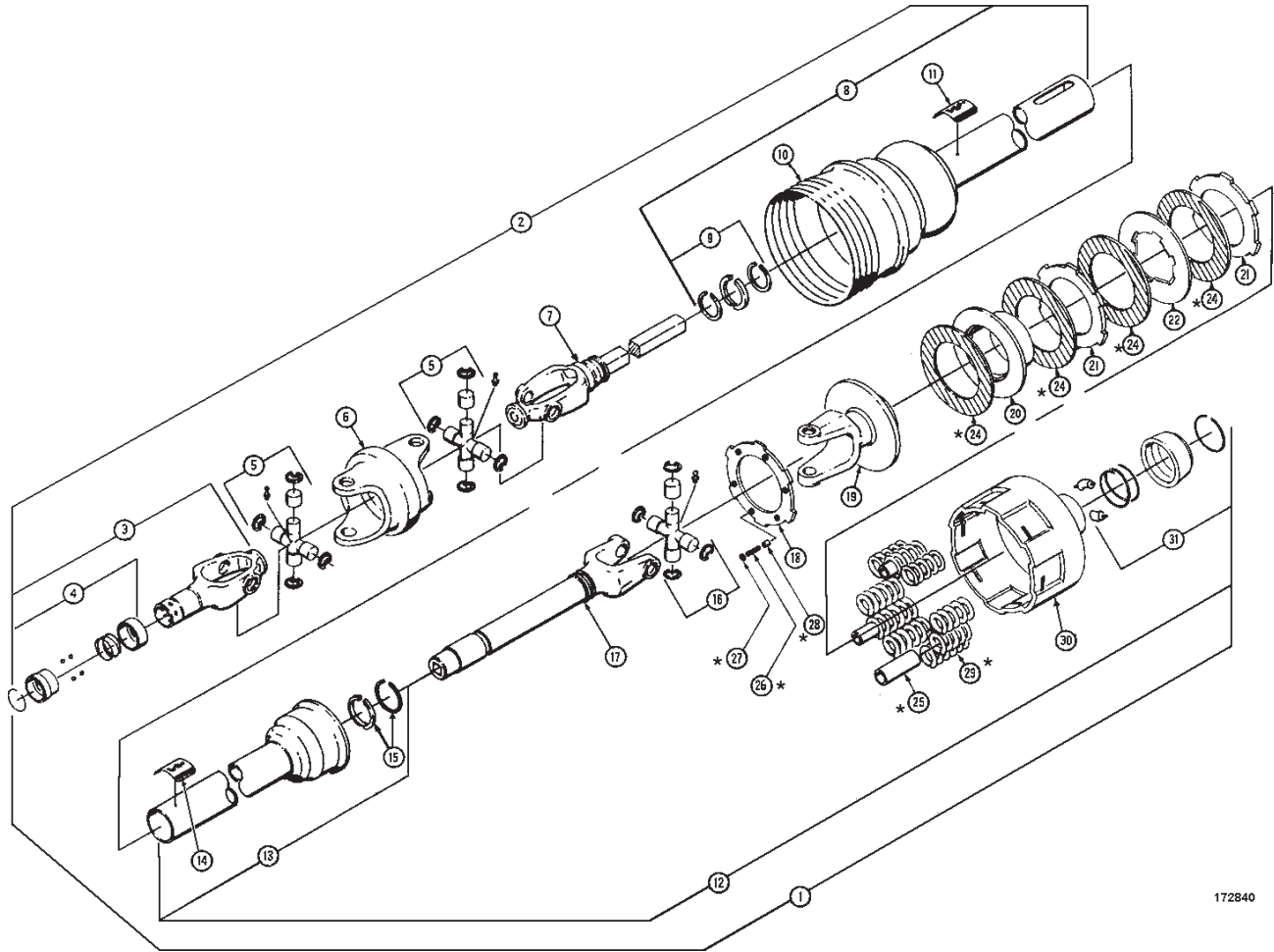

172840

PTO DRIVELINE & FRICTION CLUTCH -CV**(1000 RPM - 20 SPLINE) Weasler Constant Velocity PTO (1-3/4" YOKE)*****PTO parts are used on units before serial number (8018-1114 1000 RPM), (8024-580 1000 RPM).***

REF	PART NO	QTY	DESCRIPTION
1	172-838	1	80° CV- PTO Assembly (includes clutch pack)
2	172-841	1	Outer Joint and Shaft Half with Guard
3	172-851	1	Safety Slide Lock Yoke Assembly (1-3/4")
4	172-496	1	Slide Lock Repair Kit
5	172-852	2	Cross and Bearing Kit
6	172-303	1	Center Housing
7	172-915	1	Yoke and Shaft Assembly
8	172-916	1	Outer Guard
9	170-220	1	Nylon Repair Kit
10	172-304	1	Bell Extension with Nylon Centralizer
11	171-550	1	Safety Decal
12	172-844	1	Inner Joint and Shaft Half with Guard (includes clutch pack)
13	172-847	1	Inner Guard
14	171-799	1	Safety Decal
15	170-220	1	Nylon Repair Kit
16	170-776	1	Cross and Bearing Kit
17	172-845	1	Yoke Tube and Slip Sleeve
18	172-855	1	Lock Ring
19	172-853	1	Yoke and Plate
	173-159	1	Bushing (not shown)
20	172-854	1	Inner Drive Hub
21	172-856	2	Plate - Outer Engaged
22	172-857	1	Plate - Inner Engaged
*	172-858	1	Friction Disk Repair Kit <i>(Weasler # 19-44425)</i>
24	172-860*	4	Friction Disk
25	172-885*	3	Spacer Bushing; Spring Stop
26	172-917*	6	Set Screw "5/16" NC x 1-1/2" SOC. HD.
27	170-119*	6	Nut; 5/16" NC Hex
28	172-918*	6	Spacer
29	172-861*	12	Spring
30	172-867	1	Housing Assembly
31	171-544	1	Slide Lock Repair Kit

* Friction disk repair kit contains all items noted with an *.

PTO DRIVELINE & FRICTION CLUTCH -CV

(1000 RPM - 21 SPLINE) Weasler Constant Velocity PTO(1-3/8" YOKE)

PTO parts are used on units before serial number (8018-1114 1000 RPM), (8024-580 1000 RPM).

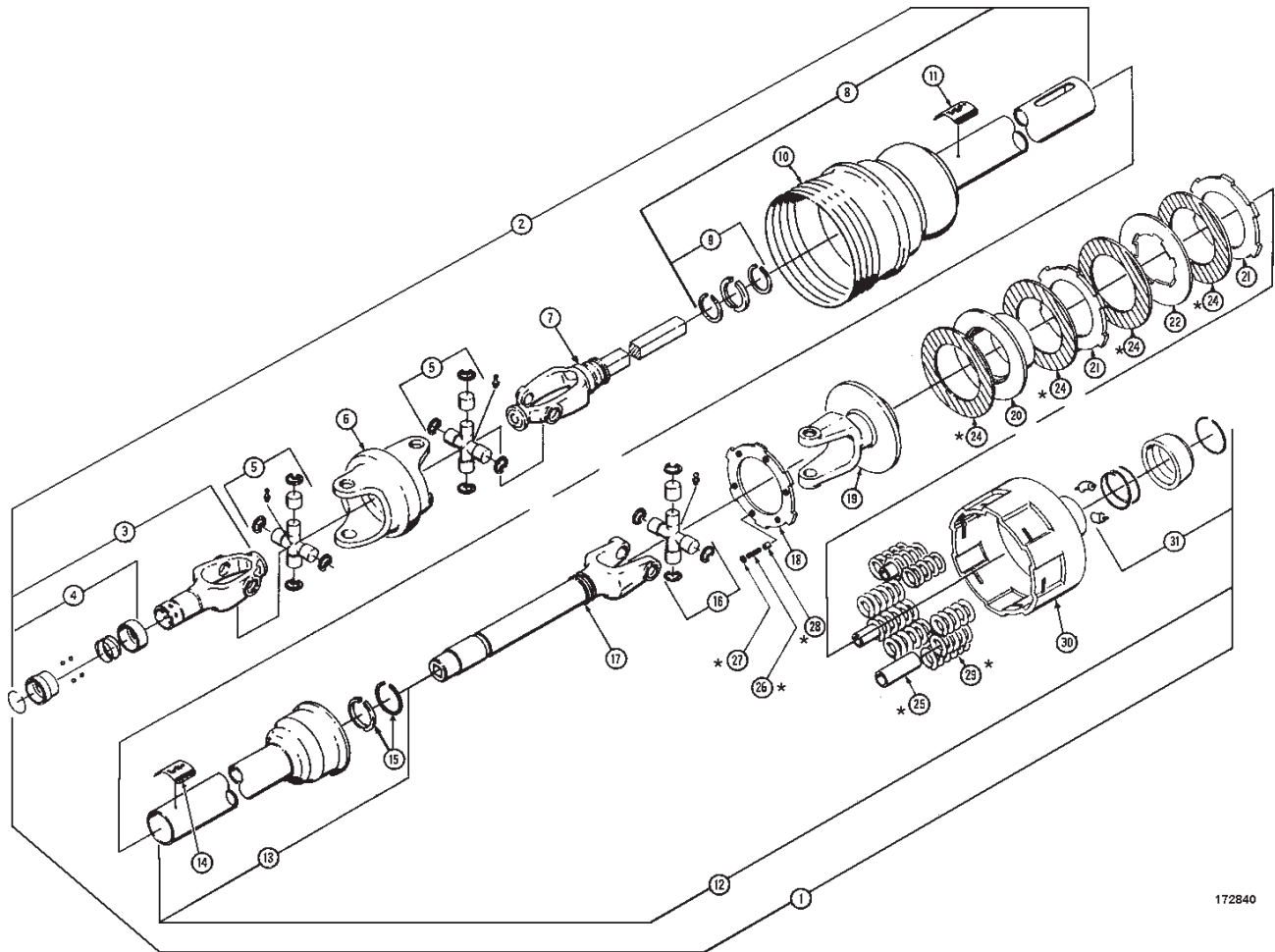

172840

PTO DRIVELINE & FRICTION CLUTCH -CV**(1000 RPM - 21 SPLINE) Weasler Constant Velocity PTO(1-3/8" YOKE)****PTO parts are used on units before serial number (8018-1114 1000 RPM), (8024-580 1000 RPM).**

REF	PART NO	QTY	DESCRIPTION
1	172-840	1	80° CV- PTO Assembly <i>(includes clutch pack)</i>
2	172-843	1	Outer Joint and Shaft Half with Guard
3	172-992	1	Slide Lock Yoke Assembly (1-3/8')
4	171-544	1	Slide Lock Repair Kit
5	172-852	2	Cross and Bearing Kit
6	172-303	1	Center Housing
7	172-846	1	Yoke and Shaft Assembly
8	172-848	1	Outer Guard
9	170-220	1	Nylon Repair Kit
10	172-304	1	Bell Extension with Nylon Centralizer
11	171-550	1	Safety Decal
12	172-844	1	Inner Joint and Shaft Half with Guard <i>(includes clutch pack)</i>
13	172-847	1	Inner Guard
14	171-799	1	Safety Decal
15	170-220	1	Nylon Repair Kit
16	170-776	1	Cross and Bearing Kit
17	172-845	1	Yoke Tube and Slip Sleeve
18	172-855	1	Lock Ring
19	172-853	1	Yoke and Plate
	173-159	1	bushing (not shown)
20	172-854	1	Inner Drive Hub
21	172-856	2	Plate - Outer Engaged
22	172-857	1	Plate - Inner Engaged
*	172-858	1	Friction Disk Repair Kit <i>(Weasler # 19-44425)</i>
24	172-860*	4	Friction Disk
25	172-885*	3	Spacer Bushing; Spring Stop
26	172-917*	6	Set Screw "5/16" NC x 1-1/2" SOC. HD.
27	170-119*	6	Nut; 5/16" NC Hex
28	172-918*	6	Spacer
29	172-861*	2	Spring
30	172-867	1	Housing Assembly
31	171-544	1	Slide Lock Repair Kit

* Friction disk repair kit contains all items noted with an *.

PTO DRIVELINE & FRICTION CLUTCH -CV

Waltershied Constant Velocity PTO

PTO parts are used on units before serial number (8018-1114 1000 RPM), (8018-1148 540 RPM), (8024-580 1000 RPM).

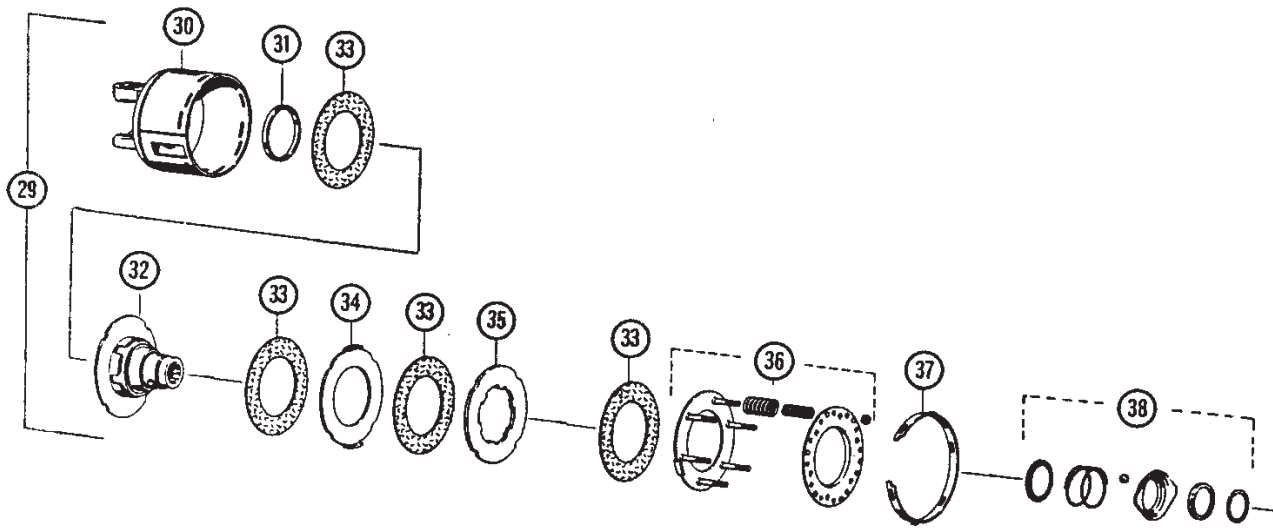
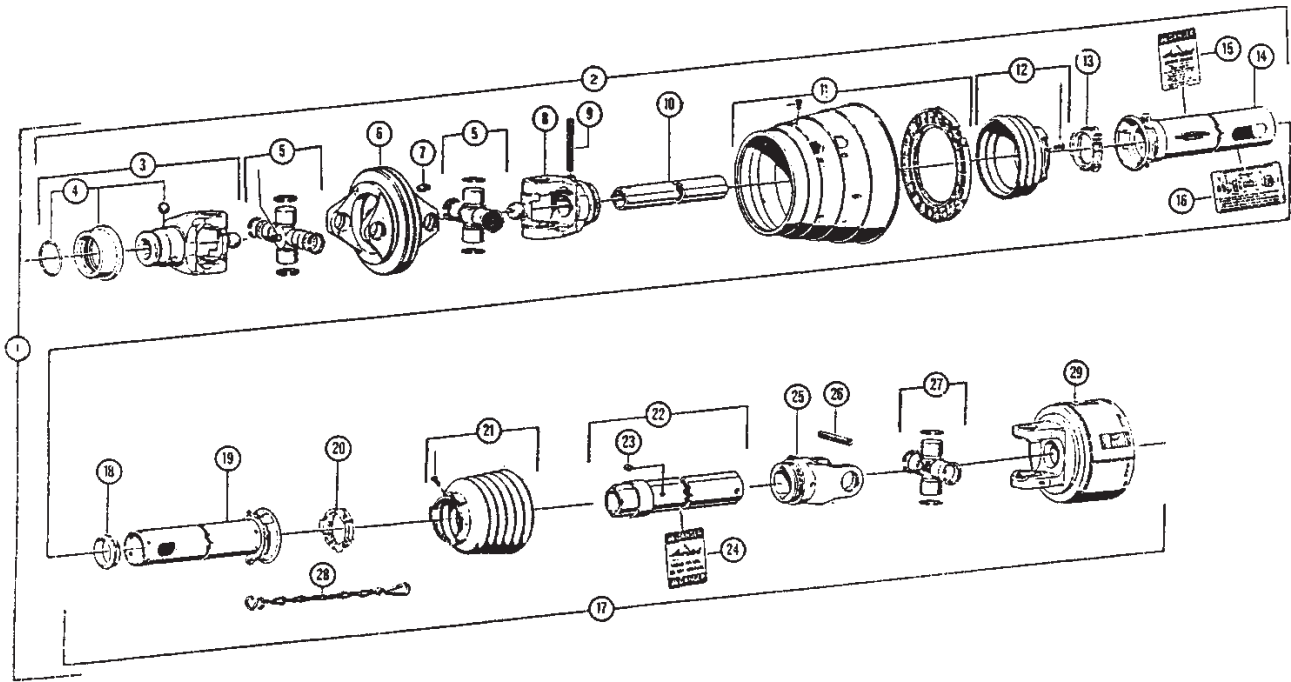

PTO DRIVELINE & FRICTION CLUTCH -CV

Waltershied Constant Velocity PTO

PTO parts are used on units before serial number (8018-1114 1000 RPM), (8018-1148 540 RPM), (8024-580 1000 RPM).

REF	PART NO	QTY	DESCRIPTION
1	172-194	1	Wide Angle PTO Drive Shaft W/Shielding (540 RPM)
1	172-211	1	Wide Angle PTO Drive Shaft W/Shielding (1000 RPM)
2	172-222	1	Male Wide Angle Half Shaft W/Shielding (540 RPM)
2	172-404	1	Male Wide Angle Half Shaft W/Shielding (1000 RPM)
3	172-200	1	End Yoke (540 RPM)
3	172-203	1	End Yoke (1000 RPM)
4	172-028	1	Quick Disconnect Kit
5	172-204	2	Cross & Bearing Kit
6	172-202	1	CV Double Yoke
7	172-208	1	Grease Zerk
8	172-201	1	Inboard Yoke
9	171-983	1	Spring Pin
10	172-196	1	Inner Profile
11	172-205	1	CV Cone & Bearing Assembly; Mtg Hrd: #172-210 Screw (2 ea)
12	172-206	1	Shield Cone; Three Rib; Mtg Hrd: #172-210 Screw (3 ea)
13	171-979	1	Bearing Ring
14	172-199	1	Outer Shield Tube W/Cap
15	171-550	1	Decal; Danger - Rotating Driveline
16	172-227	1	Decal; Lubrication Requirements
17	172-223	1	Female Half Shaft With Shielding
18	172-207	1	Support Bearing
19	172-198	1	Inner Shield Tube W/Cap
20	171-979	1	Bearing Ring
21	172-030	1	Shield Cone; Six Rib; Mtg Hrd: #172-210 Screw (3 ea)
22	172-197	1	Outer Profile & Sleeve
23	172-209	1	Grease Zerk
24	171-799	1	Decal; Danger, Shield Missing...
25	172-033	1	Inboard Yoke
26	171-983	1	Spring Pin
27	171-980	1	Cross & Bearing Kit
28	172-040	1	Safety Chain
29	***_***	1	Friction Clutch, not available as assembly
30	172-037	1	Clutch Housing
31	172-038	1	Ring
32	172-036	1	Hub & Drive Plate
33	171-977	4	Friction Disk
34	171-976	1	Drive Plate
35	171-975	1	Drive Plate
36	171-974	1	Spring Pack
37	171-978	1	Setting Ring
38	172-029	1	Quick Disconnect Flange Kit

DECAL & PAINT LIST

The following decals are listed below for your convenience. Use the operator's manual for decal location, part number and ordering.

Unit Decals:

PART NO	QTY	DESCRIPTION
172-878	1	Complete Set of Decals (8018-tow)
172-880	1	Complete Set of Decals (8024-tow)
170-490	1	Engage PTO Slowly
170-849	2	Warning...Beware Of Power Driven Parts
170-893	1	Slow Moving Vehicle Sign
171-712	1	Retighten Set Screws
171-820	4	Danger... Rotating Auger
171-821	2	Danger...Material Discharges
171-913	1	Warning...Do Not Operate
171-915	2	Danger...Shield Missing
174-686	2	Red Reflector
174-687	2	Amber Reflector
172-171	1	Caution...Read Operators Manual
172-759	1	U.S. Patent Decal
174-565	2	"8018" (8018 only)
174-566	2	"8024" (8024 only)
172-820	1	Caution...Lifting Instructions
174-720	2	"KUH N KNIGHT PROTWIN SLINGER"
174-514	1	Kuhn Knight Logo
172-883	1	Oil Level Plug
173-040	1	Caution...PTO Operation

Top Lid Decals:

PART NO	QTY	DESCRIPTION
172-821	1	Decal; Caution - Do Not Lift Here
172-599	1	Decal; Danger - Overhead Wires
172-787	2	Decal; Warning - Crushing Under Top..(Front & Rear)

Paint:

170-366 Kuhn Knight Yellow, Aerosol Can 170-367 Kuhn Knight Red, Aerosol Can
 170-812 Kuhn Knight Yellow, Quart Can 170-814 Kuhn Knight Red, Quart Can
 170-813 Kuhn Knight Yellow, Gallon Can 170-815 Kuhn Knight Red, Gallon Can

Safety Chain For Towed Equipment

PART NO 172-041

This chain is designed to retain the connection between the towing and towed machines in the event of separation of the primary attaching system. It should be used whenever the unit is transported on the highway.

Light Kit For Towed Equipment

This light kit is designed for lighting and marking of agricultural field equipment whenever the equipment is on a highway. This kit is pre-assembled, and it includes mounting hardware.

PART NO	QTY	DESCRIPTION
300-007	1	Complete Light Kit - Assembled
005448	1	Installation Instructions
141-496	2	Sheet, Light Bracket
174-675	1	Assy, tow light harness with lights and plugs
174-674	2	Red Light
174-673	2	Amber Light
174-725	4	Rubber grommet
174-775	1	Harness assy
174-724	4	Plug
172-110	1	7 Pin Female Connector

HARDWARE PART NUMBER LISTING

All fasteners are NC thread, Grade 5 unless otherwise specified.

HEX HEAD BOLTS

Size	Part No			
1/4 x 1/2	173-279	1/2 x 3/4	171-252	3/4 x 5
1/4 x 3/4	170-803	1/2 x 1	170-149	3/4 x 5 UNF
1/4 x 7/8	171-094	1/2 x 1-1/4	170-373	3/4 x 5-1/2 (Grade 8) UNF
1/4 x 1	170-310	1/2 x 1-1/2	170-002	3/4 x 6
1/4 x 1-1/2	170-068	1/2 x 1-1/2 (Grade 8)	172-951	3/4 x 6 UNF
1/4 x 2	172-986	1/2 x 1-3/4	171-774	3/4 x 6 (Grade 8)
1/4 x 2 (Grade 8)	175-073	1/2 x 2	171-802	3/4 x 7
1/4 x 2-3/4	171-203	1/2 x 2-1/4	172-387	3/4 x 7 UNF
1/4 x 3	171-403	1/2 x 2-1/2	170-885	3/4 x 7-1/2
1/4 x 3-1/2	173-640	1/2 x 2-1/2 (Full thread)	171-099	3/4 x 8
1/4 x 4	173-505	1/2 x 2-3/4	172-007	
		1/2 x 3	170-168	7/8 x 2-1/4
5/16 x 5/8	170-532	1/2 x 3-1/2	170-167	7/8 x 3
5/16 x 3/4	170-262	1/2 x 3-1/2 (Grade 8)	172-950	7/8 x 3-1/2
5/16 x 3/4 (Stainless steel)	174-787	1/2 x 4	173-111	7/8 x 4
5/16 x 7/8	170-256	1/2 x 4 (Full thread)	171-509	7/8 x 4 UNF
5/16 x 1	170-027	1/2 x 5	171-412	7/8 x 6-1/2
5/16 x 1-1/4 (Full thread)	170-188	1/2 x 6	173-506	7/8 x 7
5/16 x 1-1/2	170-372	1/2 x 6 (Grade 8)	174-944	7/8 x 7 UNF
5/16 x 1-3/4	170-263	1/2 x 6-1/2	173-711	7/8 x 8
5/16 x 2	172-987	1/2 x 7	174-328	7/8 x 8 UNF
5/16 x 2-1/2	170-369	1/2 x 7-1/2	175-107	
5/16 x 3	170-295	1/2 x 8-1/2	170-504	1 x 3-1/2
5/16 x 3-1/4	171-639	1/2 x 11	170-506	1 x 4
5/16 x 3-1/2	173-748			1 x 4 (Grade 8)
5/16 x 4	170-293	9/16 x 1	173-699	1 x 7 UNF
5/16 x 4-1/2	170-294	9/16 x 1-1/4	173-700	1 x 8
5/16 x 5 (Grade 8)	172-983	9/16 x 1-1/2	173-701	1 x 8 (grade 8) UNF
5/16 x 5-1/2 (Grade 8)	172-952	9/16 x 2	172-219	1-1/4 x 4-1/2 (grade 8)
3/8 x 3/4	170-439	5/8 x 1	171-087	M8 x 16MM (Grade 8.8)
3/8 x 3/4 (Stainless steel)	174-788	5/8 x 1-1/4	171-366	M8 x 20MM (Grade 8.8)
3/8 x 7/8	170-268	5/8 x 1-1/2	170-153	M8 x 25MM (Grade 8.8)
3/8 x 7/8 (soc. hd.capscrew)	172-044	5/8 x 1-3/4 (Full thread)	170-030	M10 x 22MM (Grade 8.8)
3/8 x 1	170-054	5/8 x 2	170-009	M10 x 25MM (Grade 8.8)
3/8 x 1-1/4	170-005	5/8 x 2 (Full thread)	171-772	M12 x 25MM (Grade 8.8)
3/8 x 1-1/4 (Stainless steel)	174-917	5/8 x 2-1/4	173-009	M12 x 35MM (Grade 8.8)
3/8 x 1-1/2	170-368	5/8 x 2-1/2	172-381	M12 x 40MM (Grade 12.9)
3/8 x 1-3/4	172-383	5/8 x 2-1/2 (Full thread)	170-129	M12 x 45MM (Grade 10.9)
3/8 x 2	170-245	5/8 x 2-3/4	172-356	M14 x 30MM (Grade 8.8)
3/8 x 2-1/4	170-320	5/8 x 3	170-258	
3/8 x 2-1/2	170-257	5/8 x 3-1/2	170-038	CARRIAGE BOLTS
3/8 x 2-1/2 (Full thread)	170-128	5/8 x 4	170-371	1/4 x 1-1/4 (Grade 2)
3/8 x 2-1/2 (Lag)	171-775	5/8 x 4-1/2	170-067	1/4 x 1-1/2 (Grade 2)
3/8 x 3	170-380	5/8 x 5	170-065	1/4 x 2 (Grade 2)
3/8 x 3-1/2	170-292	5/8 x 5-1/2	172-421	1/4 x 2-1/2 (Grade 2)
3/8 x 4	170-877	5/8 x 6	170-381	1/4 x 2-3/4 (Grade 2)
3/8 x 4-1/4 (Black oxide)	171-813	5/8 x 6-1/2	173-777	1/4 x 3
3/8 x 4-1/2	170-519	5/8 x 7-1/2	173-019	
3/8 x 5	170-493	5/8 x 9-1/2	171-039	5/16 x 1 (Grade 2)
3/8 x 5-1/2	174-196			5/16 x 1-1/2 (Grade 2)
3/8 x 5-1/2 (Full thread)	170-593	3/4 x 1-1/2	173-507	5/16 x 2-1/2 (Grade 2)
3/8 x 6	174-304	3/4 x 2	171-768	5/16 x 5-1/2 (Grade 2)
3/8 x 6-1/2	171-291	3/4 x 2 (Full thread)	170-058	
3/8 x 7	172-587	3/4 x 2 (Grade 8)	171-877	3/8 x 3-1/2 (Grade 2)
		3/4 x 2-1/4	171-275	3/8 x 4-1/2 (Grade 2)
7/16 x 3/4	170-265	3/4 x 2-1/2	170-374	3/8 x 5 (Grade 2)
7/16 x 1	170-032	3/4 x 2-1/2 (Grade 8)	175-055	3/8 x 6-1/2 (Grade 2)
7/16 x 1-1/4	170-354	3/4 x 3	170-014	3/8 x 8 (Grade 2)
7/16 x 1-1/4 (Grade 8)	174-216	3/4 x 3 UNF	173-776	3/8 x 13 (Grade 2)
7/16 x 1-1/2	170-059	3/4 x 3-1/2	170-195	3/8 x 13-1/2 (Grade 2)
7/16 x 2	170-356	3/4 x 3-1/2 (Grade 8)	171-899	
7/16 x 2-1/2	170-379	3/4 x 4	170-419	1/2 x 1-1/2 (Grade 5)
7/16 x 3	170-270	3/4 x 4 (Grade 8) UNF	173-579	1/2 x 6-1/2 (Grade 2)
7/16 x 5-1/2	170-377	3/4 x 4-1/2	170-846	1/2 x 9 (Grade 2)
7/16 x 6	170-378	3/4 x 4-1/2 (Grade 8)	173-039	
		3/4 x 4-1/2 (Grade 8) UNF	173-588	5/8 x 2

KUHN KNIGHT INC.

1501 West 7th Ave. Brodhead, WI 53520-0167

701 Cherry Ave. Greeley, Co. 80632

PART NUMBER INDEX

8018/8024TR 005816 R093002

101-598	5	133-565	13,15,17	136-974	7	170-813	40
101-613	13,15,17	133-636	11	136-979	21	170-814	40
101-614	17	133-637	11	136-980	21	170-815	40
101-615	17	134-086	9	136-981	21	170-835	7,11
101-616	17	134-155	9,19	136-989	13	170-845	9
101-617	17	134-459	7	140-468	22	170-849	40
101-636	9	134-460	11	141-496	40	170-865	5,13,15,17
101-637	5	134-461	7	142-003	11	170-893	40
101-643	15	134-464	17	170-008	7,11	170-950	19
101-644	15	134-481	19	170-028	5	170-952	19
101-645	15	134-649	11	170-031	11	171-030	9,22
101-646	15	134-666	11	170-037	11	171-045	9
101-761	9	134-670	7	170-053	7	171-137	19
101-911	9,19	134-792	7	170-056	13,15	171-251	22
101-986	11	134-831	11	170-066	11	171-252	9
101-988	11	134-842	7	170-073	9,11	171-309	9
102-059	11	134-846	11	170-074	11	171-393	5
102-073	22	134-875	11	170-112	17	171-442	22
102-205	19	134-889	9	170-119	27,29,31	171-460	22
102-207	19	134-890	21	170-119	33,35,37	171-544	27,29,31
102-208	11	134-892	19	170-122	22	171-544	33,35,37
102-212	7	134-893	19	170-125	5	171-550	23,24,25,27
102-213	19	134-899	11	170-131	17	171-550	29,31,33
102-214	19	135-538	7	170-132	17	171-550	35,37,39
102-215	7	135-539	7	170-152	19	171-585	7
102-216	21	135-540	7	170-161	22	171-586	11
102-217	21	135-541	7	170-168	19	171-607	7
102-220	21	135-550	19	170-220	27,29,31	171-610	5
102-221	21	135-551	7	170-220	33,35,37	171-611	5
102-222	21	135-555	21	170-232	9	171-612	5
102-223	21	135-555	21	170-233	22	171-613	5
102-224	19	135-586	11	170-235	22	171-614	5
102-225	19	135-587	21	170-236	11,17	171-615	5
102-226	19	135-588	21	170-244	5	171-696	11
102-234	22	135-589	21	170-262	5	171-712	40
102-235	21	135-590	21	170-364	19	171-769	7
102-237	21	135-594	21	170-366	40	171-782	22
102-238	21	135-595	21	170-367	40	171-799	23,24,25
102-239	21	135-596	19	170-369	27,29,31	171-799	27,29,31,33
102-240	21	135-597	19	170-466	22	171-799	35,37,39
102-241	21	135-598	7	170-490	40	171-808	15
102-515	13	135-607	9	170-499	7	171-809	15
102-516	13	135-608	11	170-509	5	171-814	5
102-517	13	135-610	5	170-518	9	171-815	15
102-518	13	135-611	19	170-545	17	171-820	40
102-519	21	135-612	19	170-546	17	171-821	40
102-520	21	135-613	7	170-550	17	171-823	15
102-521	21	135-614	7	170-553	17	171-824	15
103-517	21	136-213	22	170-554	17	171-825	13
130-128	7	136-234	21	170-556	17	171-825	15
130-175	7	136-235	21	170-705	17	171-826	15
133-277	11	136-257	21	170-755	17	171-826	17
133-476	7	136-284	19	170-776	27,29,31	171-827	13,15,17
133-530	7	136-285	19	170-776	33,35,37	171-828	13,15
133-556	21	136-286	9	170-800	9	171-829	13,15
133-557	21	136-495	11	170-812	40	171-830	13,15

KUHN KNIGHT INC.

1501 West 7th Ave. Brodhead, WI 53520-0167

701 Cherry Ave. Greeley, Co. 80632

43

PART NUMBER INDEX

171-831	15	172-284	17	172-873	19	174-732	27
171-832	13,15	172-285	13	172-874	7	174-733	27
171-833	13,15	172-303	27,29,31	172-875	11	174-775	40
171-913	40	172-303	33,35,37	172-876	9	174-877	23
171-915	40	172-304	27,29,31	172-878	40	174-878	24
171-919	9	172-304	33,35,39	172-880	40	174-879	25
171-929	7	172-404	39	172-883	40	174-956	23
171-934	19	172-421	11	172-885	33,35,37	174-959	23,24,25
171-935	7,19	172-422	11	172-894	7	174-961	23,24,25
171-968	19	172-496	29,35	172-915	29,35	174-962	23,24,25
171-974	39	172-599	22,40	172-916	29,35	174-963	24,25
171-975	39	172-751	9,19	172-917	33,35,37	174-964	23,24,25
171-976	39	172-759	40	172-918	33,35,37	174-965	23,24,25
171-977	39	172-772	11	172-991	27,33	174-966	23,24,25
171-978	39	172-787	22,40	172-992	31,37	174-967	25
171-979	23,24,25,39	172-794	22	172-993	29	174-968	23,24,25
171-980	23,24,25,39	172-806	22	172-994	29	174-973	23
171-983	23,24,25,39	172-807	22	173-040	40	174-974	23
171-989	19	172-808	22	173-114	22	174-975	24
171-998	22	172-809	22	173-159	33,35,37	174-976	24,25
172-005	9	172-820	40	173-164	7	174-977	25
172-024	5	172-821	22,40	173-195	27	175-035	11
172-028	23,24,39	172-822	5	173-196	31	180-630	5
172-029	39	172-823	5	173-197	29		
172-030	23,24,25,39	172-827	7	173-198	29,31		
172-033	23,24,25,39	172-828	7	173-200	27,31		
172-034	23	172-829	7	173-201	29		
172-036	39	172-830	7	173-202	27,29,31		
172-037	39	172-831	7	173-203	27,29,31		
172-038	39	172-832	7	173-204	27,29,31		
172-040	23,24,25,39	172-838	35	173-205	27,29,31		
172-041	40	172-839	33	173-206	27,29,31		
172-046	19	172-840	37	173-207	29,31		
172-110	40	172-841	29,35	173-271	9		
172-171	40	172-842	27,33	173-274	9		
172-194	39	172-843	31,37	173-757	24		
172-196	39	172-844	33,35,37	173-791	25		
172-197	39	172-845	27,31,33,35,37	174-514	40		
172-198	39	172-846	27,31,33,37	174-559	17		
172-199	39	172-847	27,31,33,35,37	174-565	40		
172-200	39	172-848	27,31,33,37	174-566	40		
172-201	39	172-851	29,35	174-581	13		
172-202	39	172-852	27,29,31	174-582	13		
172-203	39	172-852	33,35,37	174-583	13		
172-204	39	172-853	33,35,37	174-584	13		
172-205	39	172-854	33,35,37	174-585	13		
172-206	39	172-855	33,35,37	174-586	13		
172-207	23,24,25,39	172-856	33,35,37	174-587	13		
172-208	23,24,25,39	172-857	33,35,37	174-673	40		
172-209	23,24,25,39	172-858	33,35,37	174-674	40		
172-210	23,24,25	172-860	27,29,31	174-675	40		
172-211	39	172-860	33,35,37	174-686	40		
172-222	39	172-861	33,35,37	174-687	40		
172-223	39	172-866	11	174-720	40		
172-227	39	172-867	33,35,37	174-724	40		
172-229	13,15	172-872	19	174-725	40		